

THERMAL STANDARDS AND MEASUREMENT TECHNIQUES

Bruce A. Hertig, Sc.D.

INTRODUCTION

The Industrial Revolution brought with it undeniable benefits to mankind, but not without certain costs. The opportunities for injury and sudden death that emerged included hazards unknown to the craftsmen in home-centered manufacturing activities. Among the more dangerous pursuits were those involving the production of basic materials, glass, metals, etc.: in short, the hot industries. Not only was there the ever-present danger of splashes, explosions and spills of molten material, but injuries and deaths mounted as the result of hard physical work in excessively hot environments. With the more enlightened current attitudes, one would assume that deaths and heat-illnesses are rare in the United States, but accurate data are not available on the frequency of heat casualties.

Other chapters in this volume provide information related to the physiologic consequences of heat stress (Chapter 30) and possible measures which may be taken to reduce stresses caused by the thermal environment (Chapter 38). It is the purpose of this chapter to outline the philosophy and development of indices for rating severity of the thermal environment, to outline the methods of assessment of the several parameters involved in the indices, and to provide guidelines for application and interpretation of the indices.

MEASUREMENT OF THE THERMAL ENVIRONMENT

Measurement of the thermal environment requires selection and placement of instrumentation such that the data acquired will be meaningful in terms of heat exchanges between the worker and the environment. For this to be achieved effectively, the investigator must (a) understand the fundamental physical laws governing thermal exchanges and (b) become familiar with the operating principles and procedures of the instruments. Such understandings will help to avoid inappropriate applications of instrumentation.

Thermal Exchanges with the Environment

The modes of heat exchange between man and the environment — evaporation, convection, radiation — have been covered qualitatively in Chapter 30, as have the environmental parameters which influence the rate of exchange. Quantitative relationships are developed in this chapter.

Convection (C) is a function of (1) the temperature gradient between the skin and the ambient air (or outer clothing), and (2) the movement of air past the surface. Stated algebraically:

$$C = f (T_a - T_s), V^n$$

In the Newtonian form and with the "Fort Knox" coefficients as revised by Hatch,^{1,2} the expression becomes

$$C = 1.0 V^{0.6} (T_a - T_s)$$

where C = Convection, kcal/hr

V = Air speed, meters/min

T_a = Air temperature, °C

T_s = Skin surface temperature, °C.

The empirically obtained exponent of 0.6 applies to forced convection over vertical cylinders,³ the geometric configuration that best corresponds to man in the working environment.

The sign convention has been chosen such that when T_a is higher than T_s, C will be positive; thus heat *gain* to the man will be positive, and heat *loss*, negative.

The coefficient includes the surface area for an "average" man (= 1.8 m²). For a particular individual whose surface area may differ from average, the value of C may be adjusted by multiplying by the ratio: actual area/1.8. The "Fort Knox" coefficients were developed on men essentially nude; the influence of clothing is considered by Belding in Chapter 38.

Radiation, R, is a function primarily of the gradient from the mean radiant temperature of the solid surroundings to skin temperature. While radiative exchange, in reality, is a function of the fourth power of absolute temperature, a first order approximation is sufficiently accurate for estimating R in the application outlined here.⁴ [Note that the value of the coefficients in reference (4) also have been modified.²]

$$R = 11.3 (T_w - T_s)$$

where R = Radiation, kcal/hr

T_w = Mean radiant temperature of the solid surroundings, °C.

and T_s = Skin surface temperature, °C.

Evaporation, E, is a function of air speed, and the difference in vapor pressure between the perspiration on the skin (vapor pressure of water at skin temperature) and the air. In hot, moist environments, evaporative heat loss may be limited by the capacity of the ambient air to accept additional moisture, in which case,

$$E_{max} = 2V^{0.6} (PW_s - PW_a)$$

where V = Air speed, meters/minute

PW_s = Vapor press. of water on skin, mmHg

PW_a = Vapor press. of air, mmHg.

In hot, dry environments E may be limited by the amount of perspiration which can be produced by the worker. The maximum sweat production that can be maintained by the average man throughout an eight-hour shift is one liter per hour, which is equivalent to an evaporative heat loss of 600 Kcal/hr. or (2400 Btu/hr).

From the above, it is evident that four environmental factors define the thermal exchanges: T_a , T_w , PW_a and V . Physiological factors, e.g., T_b , metabolism (M), are dealt with elsewhere (Chapters 30 & 38).

NOTE: Equations for C , R , and E_{max} in English units ($^{\circ}F$, ft/min, Btu/hr) are $C = 1.08 V^{0.6} (T_a - T_b)$, $R = 25 (T_w - T_b)$ and $E_{max} = 4.0 V^{0.6} (PW_a - PW_b)$, respectively.

Instruments

Thermometry. Air temperature may be measured by a variety of instruments, each of which may have advantages under certain circumstances.

1. *Mercury (or alcohol)-in-glass thermometers.* The common glass thermometer is often used for determining air temperature. But because of its very common nature, sometimes the simplest of precautions are overlooked.

Calibration. Thermometers may be in error by several degrees. Each should be calibrated over its range in a suitable medium (usually a temperature-controlled oil bath) against a known standard, e.g., Bureau of Standards certified thermometer. Only thermometers with the graduations marked on the stem should be used. Those with scale markings on a mounting board can be off by 10° ; further the stem can shift relative to the mounting board.

Range. It seems superfluous to specify that the range of the thermometer should be selected to cover the anticipated environment. But if one is careless, a $0-50^{\circ}C$ thermometer can be easily carried into a $60^{\circ}C$ environment where the mercury will break the capillary glass tube; this is not an unusual occurrence in practice.

Separation of columns. Sometimes the liquid column in a thermometer will separate. Before readings are taken, the continuity of the column should be checked. Separated columns may be rejoined by shaking, or by heating in hot water (never a flame!).

Type. If the thermometer is totally "immersed" in the air being measured, a total immersion instrument should be selected. A partial immersion thermometer will be the instrument of choice for wet bulb and globe thermometers and for the aspirated psychrometer. The depth of submersion for which a partial immersion thermometer is calibrated is usually indicated by a mark on the stem.

Breakage. Glass thermometers are the simplest to use, most readily available and cheapest of the temperature instruments considered. Yet their fragility may prove to be a hazard in certain applications. The

mercury spilt from a broken thermometer may not be of consequence in a large, well-ventilated shop, but would certainly require careful cleanup in an enclosed space, e.g., underwater chamber.

2. *Thermoelectric thermometers.* When two dissimilar metals are joined, and the temperature of the junction is changed, a small voltage is generated (Seebeck effect)⁵. Two junctions in a circuit, with one held at a known temperature ("reference junction"), form the basic elements of a thermocouple. The current flowing in the circuit resulting from the electromotive force (e.m.f.) generated may be measured directly by a galvanometer, or the e.m.f. balanced by a known source potentiometrically. The latter technique is preferred, as the length of the thermocouple (hence its resistance) becomes of no consequence when current flowing becomes zero. Each thermocouple used with a current-measuring device must be calibrated individually. With a potentiometer, only samples from the spools of wire need be calibrated, and only then if extreme precision is required. Figure 31-1 provides a schematic arrangement of the components in a thermocouple system.

Thermocouples of copper and constantan (a copper-nickel alloy) are commonly used for most environmental temperature ranges. They are easy to construct, and the wire for an individual couple costs only a few cents. However, the potentiometer will cost several hundred dollars.

The availability of small thermocouple wire, as fine as 40 gauge, makes the technique useful for measuring physiological temperatures, e.g., skin, ear canal, rectal, with the same recording or readout equipment as used for environmental temperatures. To prevent shorting out between junctions in the saline milieu of the body, thermojunctions used for physiological measurements should be electrically insulated.

Thermocouples have these advantages over mercury-in-glass thermometers:

- (1) Adaptability to specific placement. Small junctions may be placed where the bulb of the thermometer would not be appropriate, e.g., skin surface.
- (2) Remote reading. Thermojunctions may be placed at the measurement site, and read remotely — hundreds of meters away, if necessary.
- (3) Simultaneous readings from several stations may be read at one place with one potentiometer with a rotary selector switch in the circuit.
- (4) Low cost of thermocouples, once potentiometer is purchased.
- (5) Adaptability to continuous recording.
- (6) No hazards from breakage.
- (7) Equilibrium time with changing temperatures is almost instantaneous, whereas mercury-in-glass thermometers may require several minutes to reach a steady reading.

On the other hand, disadvantages include:

- (1) High initial cost of potentiometer.
- (2) Bulk of potentiometer.

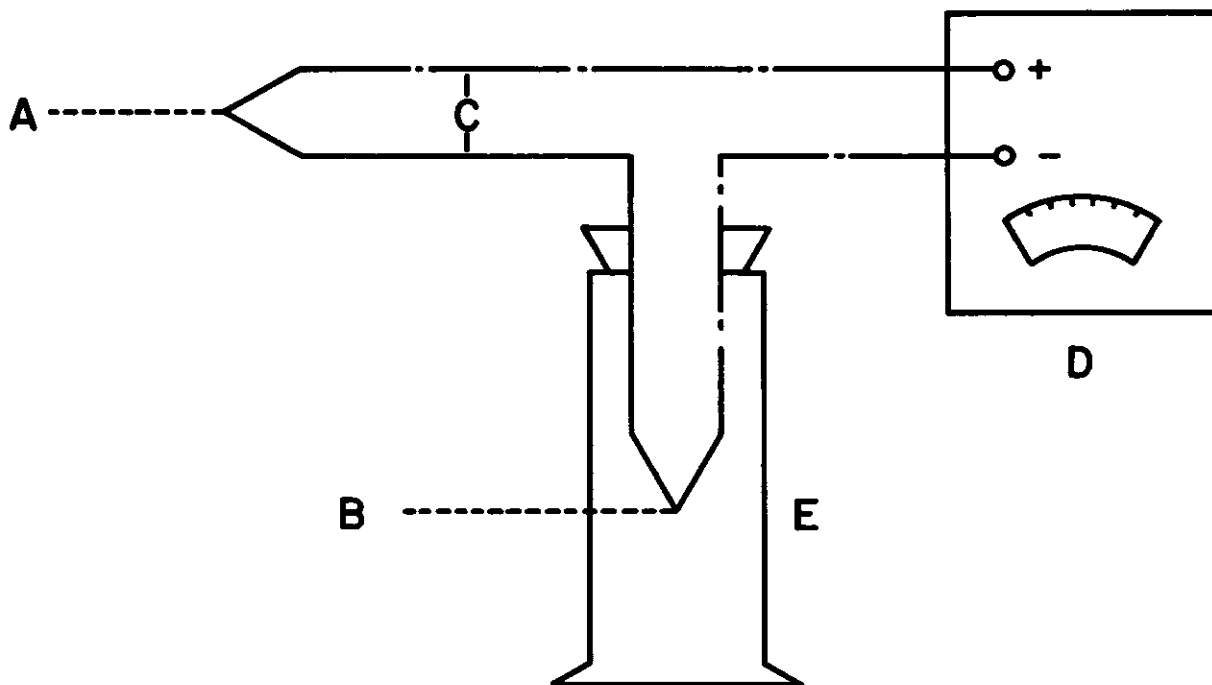

Laboratory for Ergonomics Research, Department of Mechanical and Industrial Engineering, University of Illinois at Urbana — Champaign.

Figure 31-1. Components in a Thermocouple System.

- (3) Requirement for reference junction (usually ice bath in Thermos bottle).
- (4) Requirement to run wires to measurement site.
- (5) Some technical skill required to construct thermocouples and use equipment. Laboratory training in techniques highly recommended.

3. *Thermistor thermometry.* One of the "space age" gadgets is the thermistor: thermal resistor. Thermistors are semiconductors which exhibit substantial change in resistance in response to a small change in temperature. As the resistance of the thermistor itself is measured in thousands of ohms, the resistance imposed by lead wires up to 25 meters or so is immaterial, permitting remote readings, as with thermocouples. Readout equipment is battery-powered and relatively light and portable which is convenient for field studies.

Advantages:

- (1) Simple to use with minimum training.
- (2) Less bulky and complicated to use than thermocouples.
- (3) Requires no reference junction.
- (4) Output signal may be recorded.
- (5) Variety of probes available for special applications.

Disadvantages:

- (1) Cost of readout equipment about the same as potentiometer, but thermistor probes cost about \$25.00 each. If the lead breaks,

it is not easily repaired, as are thermocouples.

- (2) Thermistor probes, though they are called "interchangeable," require individual calibration before use. Calibration of thermistor beads will shift somewhat with age, requiring annual or biennial recalibration. *Comment:* The advantages of the thermistor thermometer make it the instrument of choice for field use when mercury-in-glass thermometers are inappropriate. Regardless of the type of thermometer used, shielding of the sensor against radiant exchange may be required where walls are cooler or warmer than the air, or in direct sunlight. Heavy aluminum foil fastened loosely around the bulb provides effective shielding; however, it should not restrict the free flow of air around the sensor element. And finally, in asymmetric thermal fields readings at several locations in the occupied space may be required to provide an adequate estimate of average air temperature.

Anemometry. As noted above, heat transfer by convection and by evaporation are functions of movement of the ambient air. While the units associated with air motion — distance per unit time — suggest movement of the mass of air past a point, turbulent air with little net mass movement will be as effective in heat transfer as linear movement.

Directional instruments, useful in ventilation engineering or meteorology, are usually not applicable for assessment of heat stress. On the other hand, instruments which depend upon rate of cooling of a heated element provide readings meaningful in terms of "cooling power" of the moving air, and are thus the instruments of choice.

1. Thermoanemometers.

Willson thermoanemometer. In use, two matched thermometers are mounted about 5 cm. apart in the environment. One of the thermometer bulbs is wrapped with a fine resistance wire. Current from a battery passing through the wire heats the bulb. The second thermometer is bare. The temperature differential between the heated and the unheated thermometers depends on the current through the wire (adjustable), and the air speed. The voltage is set between 2 to 6 volts, depending on the range of air speed encountered. At high air speeds, greater heat input is required to obtain sufficient differential between the thermometers for reliable readings. Knowing this temperature differential and the voltage, the operator may find the air speed from the calibration curves supplied with each instrument. Achieving equilibrium requires 2 to 5 minutes. On the one hand, this provides an integrating effect in turbulent air, but on the other hand makes determination of air speed at many locations tedious. Its design, however, assures relatively non-directional response.

Alnor thermoanemometer. This instrument measures air motion by the rate of cooling of a heated thermocouple at the tip of the probe. One thermojunction is heated by a constant current supplied to a heater wire; the other junction is located in the air stream. The air speed governs the rate of heat removal from the heated thermocouple, which in turn determines its millivolt output. The scale is calibrated directly in feet per minute. The low mass of the thermocouple permits almost instantaneous response of the instrument. An area may be surveyed quickly, but rapid fluctuations in air motion make mean speed estimates difficult. Batteries supply the power, making the instrument portable and self-contained. The thermocouple and heater supports restrict airflow somewhat; the probe should be slightly rotated to obtain the maximum reading.

Anemotherm. The principle of operation of the Anemotherm is similar to the Alnor, though a heated resistance wire is used as one leg of a Wheatstone bridge instead of the heated thermocouple circuit.⁶ The Anemotherm also may be used to measure temperature and static pressure.

Kata thermometer. Hill⁷ developed the Kata thermometer to determine cooling power of the air, as a measure of efficiency of ventilation in factories, mines, etc. (Figure 31-2). It is essentially an alcohol-filled thermometer with an out-sized bulb. The bulb is heated in warm water until the column rises into the upper reservoir and is then wiped dry. The instrument is suspended in the air stream (it may be hand held, provided the body of the operator does not interfere with the flow of air); the fall of the column from the upper

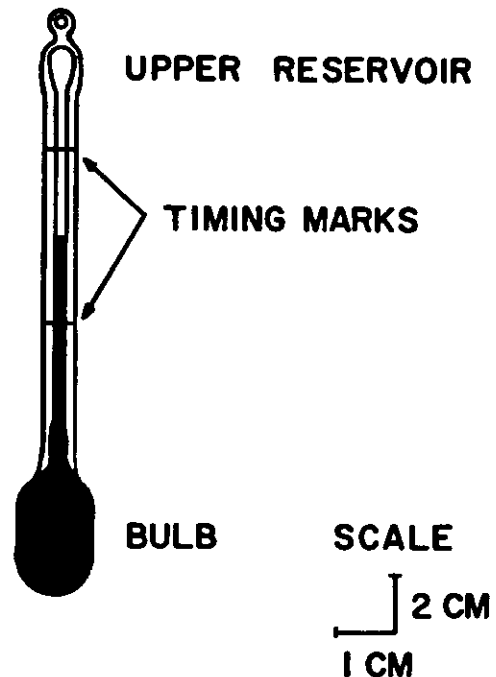

Hill, L.: The Science of Ventilation and Open Air Treatment. Part I, Med. Res. Count. Spec. Dept. No. 32, London, 1919.

Figure 31-2. Kata Thermometer.

to the lower mark etched on the stem is timed with a stopwatch. The cooling time of the Kata is a function of air speed and air temperature; the air speed is determined from nomograms accompanying the instrument.

Katas are made in several ranges for high temperature environments, as well as the standard instrument for the comfort range (upper mark 38°C, lower mark 35°C). The bulb of the Kata must be silvered to reduce the effect of radiant heat exchange. The Kata is a good instrument for estimating accurately the cooling power of air motion at low speeds, <15 meters/min. The requirements for heating above ambient make it somewhat awkward for field work, though a Thermos of hot water may be carried.

2. *Estimation of air motion.* For investigators frequently called upon to make heat stress studies, it is well worth the effort to learn to judge air motion by "feel." This permits a gross estimate of air movement without instruments on a survey or "walk through." If no motion is felt, the air speed is below 10 to 15 meters/min (30-50 ft/min). If a light breeze is felt, the speed will be about 15 to 30 meters/min. Breezes strong enough to cause movement of clothing, tousling of hair, etc., are in the range of 30-90 meters/min. Winds stronger than these are not often found within buildings, except in front of fans.

Psychrometry. The amount of water vapor in the air (humidity) controls the rate of evaporation of

water from skin surface and from other moist tissues, e.g., lungs, respiratory passages, conjunctiva of the eyes, etc. To understand the process of evaporation from these tissues into the ambient air, certain properties of liquid-vapor interfaces should be reviewed.

Water, like other liquids, will tend to saturate the surrounding space with vapor. In an enclosed vessel, the amount of water vapor per unit volume in the space above the water is dependent only on the temperature of the system (assuming constant total pressure). In accordance with Dalton's law of partial pressures, presence or absence of other species of gases in the space will have no effect on the amount of water vapor present. If all other gases are evacuated, the pressure developed is termed the true vapor pressure (or saturation pressure) of the liquid at the existing temperature. If the temperature is raised, saturation vapor pressure will increase. When the vapor pressure equals total atmospheric pressure, boiling occurs. In an open vessel where ambient air currents carry away the water vapor, continuous evaporation takes place.

"Relative humidity" (RH) is defined as the amount of moisture in the air as compared with the amount that the air could contain at saturation at the same temperature. It is usually expressed as a percentage. Thus, the amount of moisture in the air at, say, 50% RH will vary depending on the air temperature. Since it is the *amount* of

water vapor in the air ("absolute" humidity) which influences evaporation, the relative humidity cannot be used directly to compute evaporative loss.

To illustrate this point: water vapor in air saturated at 0°C exerts a vapor pressure of about 5 mm Hg. This condition might prevail on a winter's day with freezing drizzle. When this air is inhaled into the lungs, it passes over mucous membranes coated with liquid water at 37°C, corresponding to a vapor pressure of about 45 mm Hg. With this gradient of 40 mm Hg, evaporation occurs, quickly saturating the air, now warmed to 37°C. Thus, air at 100% RH enters at 0°, and air at 100% RH leaves at 37°, yet evaporation has occurred, and the moisture content differs greatly from inhaled to exhaled air. On exhalation, the air cools and the new moisture burden condenses out, creating a visible cloud.

Given the relative humidity and the temperature, the water vapor pressure may be determined. In fact, any two properties (temperature, total heat content, dew point, relative humidity, etc.) completely define the thermodynamic state of the air-water vapor mixture.^a The psychrometric chart is a convenient graphical representation of the mathematical interrelationships of these parameters (Figure 31-3 inset). The saturation line (100% relative humidity) marks the upper limit of moisture holding capacity of the air (Figure 31-3). Note that at saturation, the dry-bulb, wet-

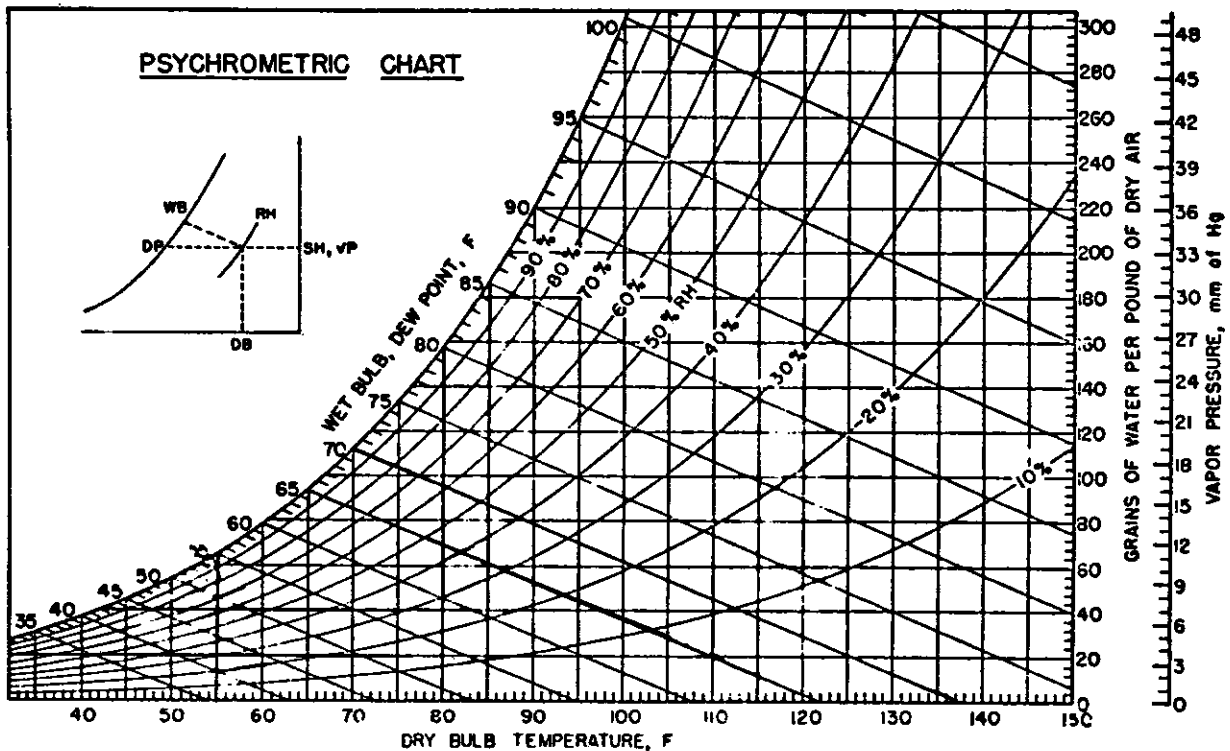

Powell, C. H., Hosey, A. D. (eds): The Industrial Environment — Its Evaluation and Control, 2nd Edition. Public Health Services Publication No. 614, 1965.

Figure 31-3. Psychrometric Chart and Vapor Pressure Nomograph.

bulb, and dew-point temperatures are equal.

Sling psychrometer. This instrument consists of two thermometers clamped in a frame which in turn is fastened to a swivel handle. A cotton wick dipped in distilled water covers one thermometer; the other is bare. The terms "wet bulb" and "dry bulb" temperatures originated from this type of instrument. When it is rapidly whirled, water evaporates from the wick, cooling the bulb. The rate of evaporation from the wick is a function of the vapor pressure gradient, determining in turn the depression of the wet bulb thermometer reading below the dry bulb. The vapor pressure can be read directly from the psychrometric chart, or tables.⁹

A few simple precautions should be observed in the use of the sling psychrometer. Usually one minute of swinging adequately cools the wet bulb to its lowest reading. It is advisable to check the reading, and then swing again for a few seconds. (Repeat if the temperature continues to fall.) There should be no obstructions in the path of the swinging thermometers. The use of distilled water prolongs the usefulness of the wick. When dirty, it may be restored by washing with detergent and thorough rinsing. It should also be noted that thermal radiation can cause rather large errors in both dry- and wet-bulb temperatures taken with a sling psychrometer.

Motor-driven psychrometer. Several types of aspirated psychrometers are available, battery-powered for field use, as well as conventional laboratory instruments. These accomplish the same end as the sling psychrometer; air motion across the thermometer bulbs is created mechanically rather than whirling by hand.

Hair hygrometer. Human hair absorbs and desorbs moisture with changes in atmospheric humidity. The length of hair under tension changes in turn with its moisture content. This motion is transmitted through a system of levers to a pointer indicating the relative humidity. Fitted with a pen, the pointer records the relative humidity on a revolving drum.⁶

Radiometry. Measurement of the mean radiant temperature of the solid surroundings (T_r) for evaluation of thermal stress is most often effected by means of a blackened sphere, or Vernon globe.¹⁰ More precise measurements of the radiant field may be made by radiometers of various designs, or by surface pyrometry. For these more precise techniques, refer to other sources, such as Fanger,¹¹ Gage,¹² or Longley *et al.*¹³

Vernon Globe (Black Globe). The Vernon Globe, or Black Globe, consists of a copper sphere about 15 cm. in diameter, the exterior of which is painted flat black. A hole for a thermometer (thermojunction or thermistor may be used) and a tab for a wire by which to hang it, complete the instrument (Figure 31-4). Copper toilet floats have been used with success, but spun spheres are usually preferred.

To estimate the mean radiant temperature at some given point in an enclosure, the globe is placed at the desired location. The temperature of the globe is measured by the thermometer after

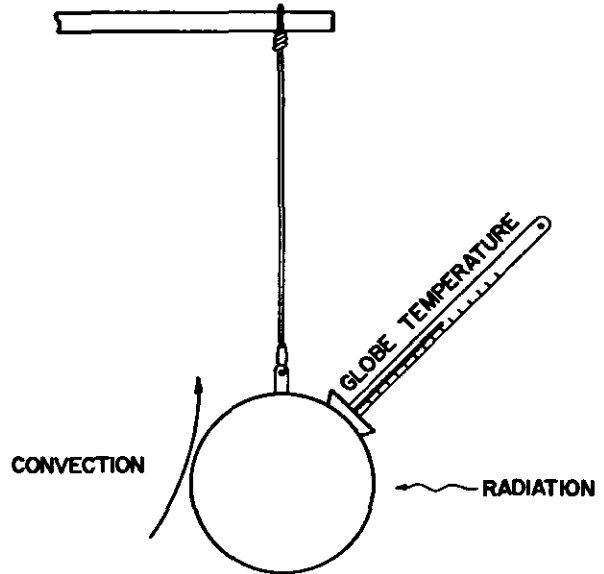

Vernon, H. M.: The measure of radiant heat in relation to human comfort. *J. Physiol.* 70, Proc. 15, 1930.

Figure 31-4. Vernon Globe (Black Globe).

thermal equilibrium has been established, usually about 15 to 20 minutes. At equilibrium, heat loss (or gain) of the globe by convection is balanced by heat gain (or loss) by radiation.

The mean radiant temperature at the globe location may be calculated by the equation:

$$T_w^* = 100 \sqrt{\left(\frac{T_r}{100}\right)^4 + 2.48 V (T_r - T_a)}$$

T_r^* = Vernon globe temp, °Kelvin

V & T_a = as before.

where T_w^* = mean radiant temp, °Kelvin ($273 + ^\circ\text{C}$)

T_w^* as calculated from this expression is an effective wall temperature (absolute). It represents the temperature of a "black" enclosure of uniform wall temperature which would provide the same heat loss or gain as the environment measured.

INDICES OF THERMAL STRESS

The search for a scheme to integrate the several environmental, physiological and behavioral variables affecting heat transfer from man to the environment into a simple index has occupied scores of engineers and physiologists for decades. Recent reviews provide breadth and depth for analyses of the many rating scales which have been proposed.^{14,15} The purpose here is to outline those which have emerged as the most commonly encountered in evaluation and control of industrial heat stress.

Effective Temperature. The search for design criteria for thermal comfort in occupied spaces led to the development of the "Effective Temperature" scale (E.T.). This concept was introduced in 1923 by Houghten and Yaglou;¹⁶ their work was

Instructions for use: Stretch a thread or place a rule to join dry-bulb and wet-bulb temperatures. Note where this cuts appropriate air velocity line and read effective temperature at this point on grid lines.

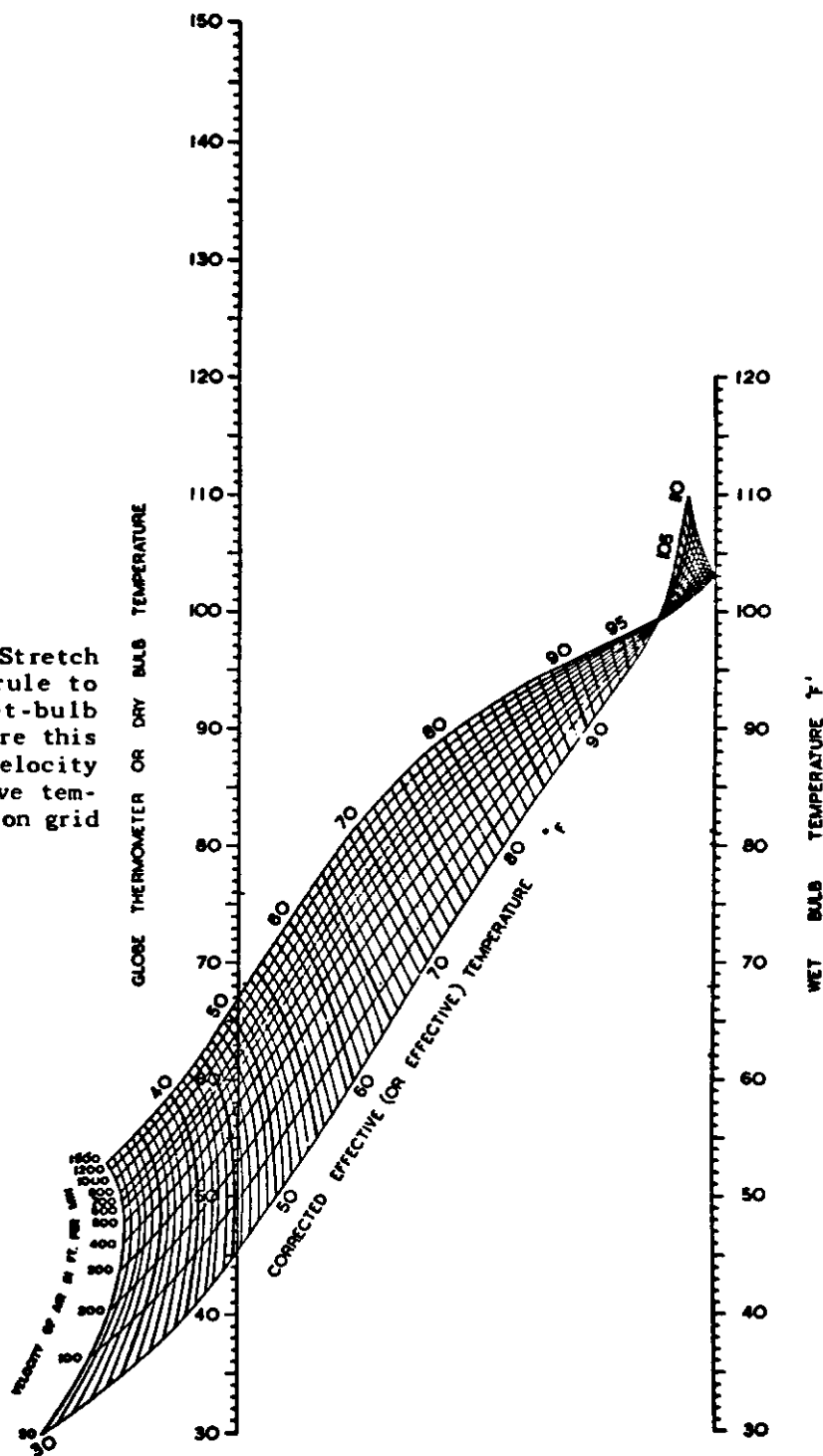

Powell, C. H., Hosey, A. D. (eds): The Industrial Environment — Its Evaluation and Control, 2nd Edition. Public Health Services Publication No. 614, 1965.

Figure 31-5. Chart Showing Normal Scale of Corrected Effective (or Effective) Temperature. Instructions for use: Stretch a thread or place a rule to join dry-bulb and wet-bulb temperatures. Note where this cuts appropriate air velocity line and read effective temperature at this point on grid lines.

sponsored by the American Society of Heating and Ventilating Engineers. Briefly, the objective was to define the various combinations of dry-bulb temperature, air motion, and humidity which would provide the same thermal sensation to the occupants. Subjects were exposed first to one combination and then another of the parameters (wall temperature was the same as air temperature $T_w = T_a$). On the basis of a large number of trials, nomograms were developed which characterized equivalent environments, expressed in terms of the temperature of a still, saturated environment.

Through the years, the original concept has been refined and modified by many investigators; among other things, methods of correcting for radiant heat exchange have been included. The early nomograms were psychrometric charts with lines of E.T. superimposed (see earlier editions of ASHVE Guide, e.g., 34th ed., 1956, for these forms of the E.T.). A separate nomogram was required for each air velocity. The present form of the scale incorporates the modifications into a single chart. Figure 31-5 shows the "normal" E.T. scale which relates to people wearing light weight summer clothing, similar to workers' uniforms. There is another E.T. scale for seminude men called the "basic" scale.

Example: Given dry bulb = 76°F, wet bulb = 55°F, air speed = 100 ft/min (English units used in the Chart), find E.T. = 67. That is, the given environment would provide the same thermal sensation as one with dry- and wet-bulb temperatures of 67°F, and no air motion. (In reality, "still" air approximated 25 ft/min, or 8 m/min.)

In spite of its widespread use, the E.T. has serious limitations, particularly as an index of heat stress:

- It was developed on transient thermal sensations. This tended to neglect the importance of sorption or desorption of moisture in the subject's clothing.
- The scale was developed using clothed subjects in dress of that day.
- The subjects were sedentary. Later modifications were made to include the effect of metabolic rate.
- The scale was designed primarily for environments reasonably near the comfort zone. Extrapolation to thermally stressful environments is tenuous.

Heat Stress Index (HSI). The Heat Stress Index was developed by Belding and Hatch at the University of Pittsburgh during the mid-1950's.¹⁷ Their index combines the environmental heat (radiation and convection, R and C) and metabolic heat (M) into an expression of stress in terms of requirement for evaporation of sweat (E_{req}).

Stated algebraically:

$$M \pm R \pm C = E_{req}$$

The resulting physiologic strain is determined by the ratio of the stress (E_{req}) to the maximum evaporative capacity of the environment, E_{max} (see above). Thus, the HSI is calculated:

$$HSI = \frac{E_{req}}{E_{max}} \times 100$$

E_{req} and E_{max} may be computed by means of the equations given on pg. 274. A more convenient means is offered by a nomogram developed by McKarns and Brief¹⁸ (Figure 31-6). This nomogram is based on further revisions of the Fort Knox coefficients, which provide a 30 percent reduction in R, C, and E_{max} for the average man wearing light work clothing. The following equations were used in the nomogram development:

$$R = 17.5 (T_w - 95)$$

$$C = 0.756 V^{0.6} (T_a - 95)$$

$$E_{max} = 2.8 V^{0.6} (42 - PW_a)$$

where R = Radiant heat exchange, Btu/hr

C = Convective heat exchange, Btu/hr

E_{max} = Max evaporative heat loss, Btu/hr

T_w = Mean radiant temp. °F

T_a = Air temp. °F

V = Air velocity, ft/min.

PW_a = Vapor press, mmHg.

Caution: The original nomogram of Belding and Hatch is being widely reproduced in texts and handbooks even today, in spite of the availability for more than a decade of these revised coefficients.

The sample solution outlined below and shown in Figure 31-6 illustrates the use of the nomogram.

Example: Given $T_g = 130^\circ\text{F}$, $T_a = 100^\circ\text{F}$, $T_{wb} = 80^\circ\text{F}$, $V = 50$ ft/min, and $M = 2000$ Btu/hr.

Step 1. Determine convection. Connect 50 fpm (column I) with $T_a = 100^\circ\text{F}$ (column II). Read C = 40 Btu/hr (column III).

Step 2. Determine E_{max} . From the psychrometric chart (Figure 31-3), read dew point of 73°F from dry and wet bulb temperatures. Connect column I and column IV from $V = 50$ to dew point = 73 (line 2). Read $E_{max} = 620$ (column V).

Step 3. Determine constant, K. Connect $V = 50$, column I, with $T_g - T_a$ (130-100) = 30, Column VI. Read K = 22 (column VII).

Step 4. Determine T_w . Enter K = 22 in lower diagram, column VII. Connect this to $T_g = 130$, column VIII. Read $T_w = 155$, column IX.

Step 5. Follow the slanting line to column X, read R = 1050 Btu/hr.

Step 6. Connect R = 1050 with M = 2000 (column XI); read R + M = 3050 on column XII.

Step 7. Enter C = 30 in column III of lower figure; connect with R + M = 3050, in column XII, read $E_{req} = 3090$ Btu/hr on column XIII.

Step 8. Enter $E_{max} = 620$ (step 2) on column V of lower diagram, and connect with $E_{req} = 3090$ Btu/hr, column XIII. Read allowable exposure time = 6 min.

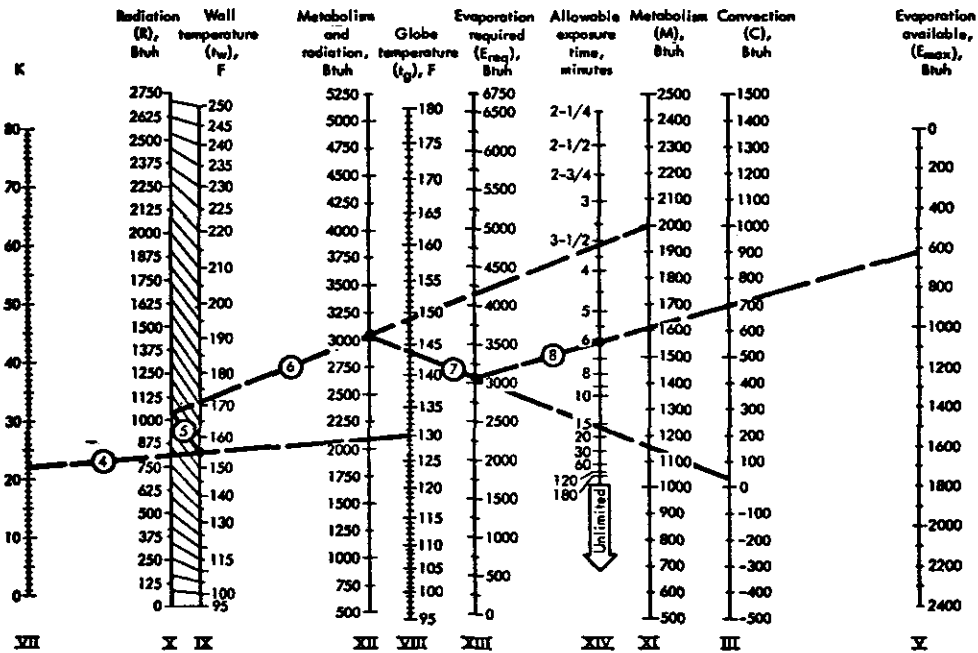
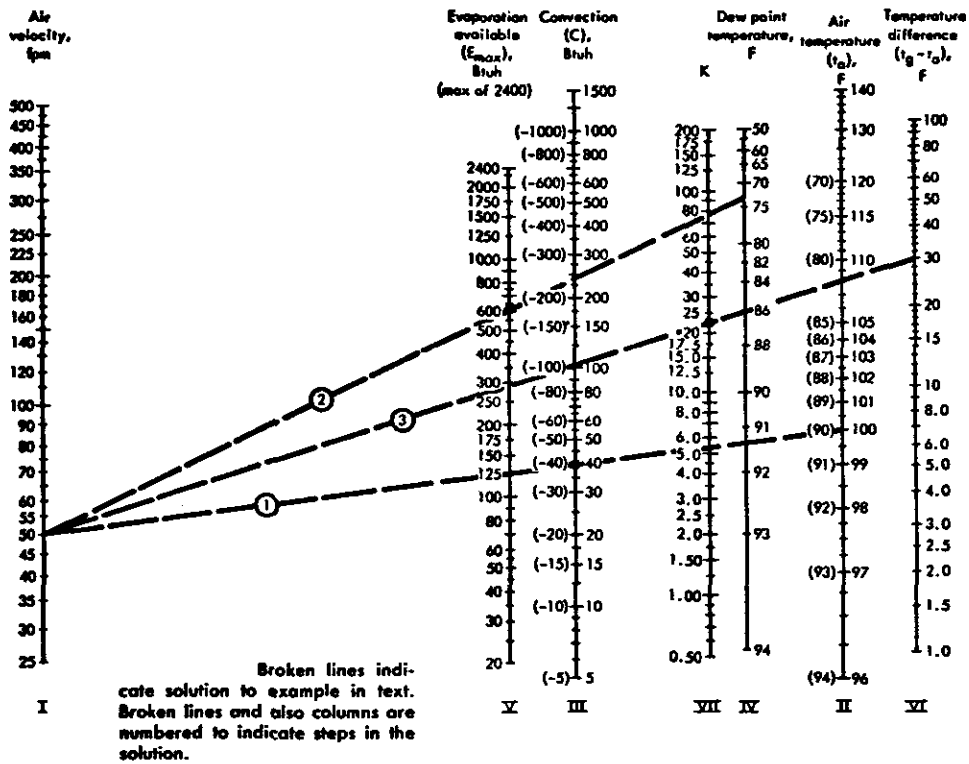

McKarns, J. S., Brief, R. S.: Nomographs give refined estimates of heat stress index. Heat Pip. Air Condit. 38:113, 1966.

Figure 31-6. Nomograph Developed by McKarns & Brief Incorporating the Revised Fort Knox Coefficients.

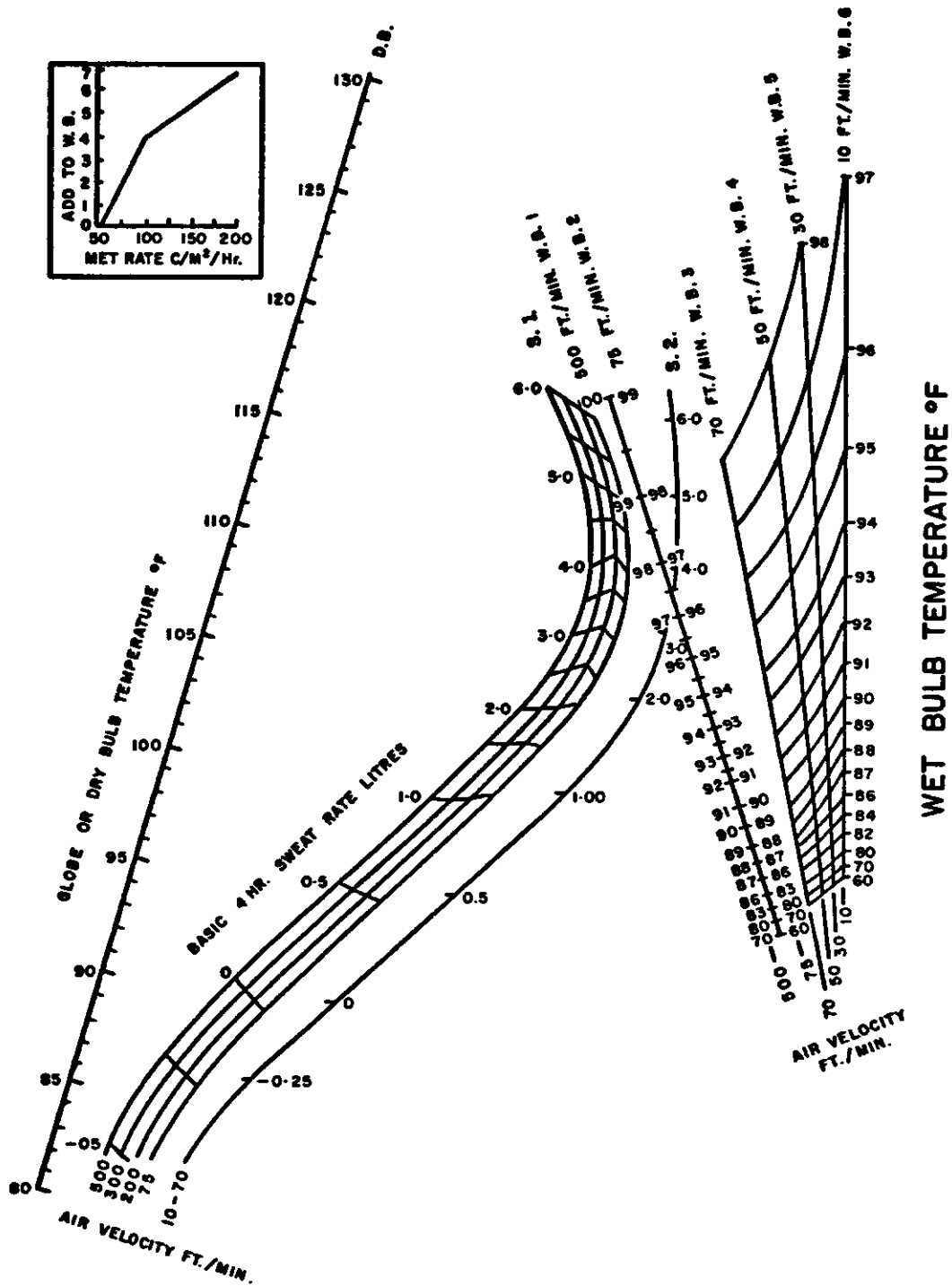

McArdle, B., Dunham, W., Holling, H. E., et al: Med. Res. Coun. R.N.P. Rep. 47:391, 1947.
 Figure 31-7. Nomogram for the Prediction of the 4-Hour Sweat Loss of Fit, Acclimatized Young Men, Sitting in Shorts. The small inset chart gives the degrees F to be added to the wet bulb for metabolic rates between 50-100K Cals/m²/Hr.

Computation of the HSI value yields:

$$\text{HSI} = \frac{3090}{620} \times 100 = 500.$$

In their original paper, Belding and Hatch presented physiologic interpretations for various levels of HSI (Table 31-1). As can be seen, 500 greatly exceeds the maximum strain tolerable. The addition by McKarns and Brief of tolerance times for HSI's in excess of 100 is a valuable contribution.

Predicted Four Hour Sweat Rate (P₄SR). McArdle *et al.*¹⁹ developed a heat stress rating scheme based upon the sweat loss (in liters) that different environmental conditions would evoke: hence, the name "Predicted Four Hour Sweat Rate." Figure 31-7 is the latest version of the nomogram, incorporating the effects of clothing and level of activity.

TABLE 31-1.

Evaluation of Values in Belding and Hatch HSI.

Index of Heat Stress (HSI)	Physiological and Hygienic Implications of 8-hr. Exposures to Various Heat Stresses
-20	Mild cold strain. This condition frequently exists in areas where men recover from exposure to heat.
-10	
0	No thermal strain.
+10	Mild to moderate heat strain. Where a job involves higher intellectual functions, dexterity, or alertness, subtle to substantial decrements in performance may be expected. In performance of heavy physical work, little decrement expected unless ability of individuals to perform such work under no thermal stress is marginal.
20	
30	
40	Severe heat strain, involving a threat to health unless men are physically fit. Break-in period required for men not previously acclimatized. Some decrement in performance of physical work is to be expected. Medical selection of personnel desirable because these conditions are unsuitable for those with cardiovascular or respiratory impairment or with chronic dermatitis. These working conditions are also unsuitable for activities requiring sustained mental effort.
50	
60	
70	Very severe heat strain. Only a small percentage of the population may be expected to qualify for this work. Personnel should be selected (a) by medical examination, and (b) by trial on the job (after acclimatization). Special measures are needed to assure adequate water and salt intake. Amelioration of working conditions by any feasible means is highly desirable, and may be expected to decrease the health hazard while increasing effi-
80	
90	

ciency on the job. Slight "indisposition" which in most jobs would be insufficient to affect performance may render workers unfit for this exposure.

100 The maximum strain tolerated daily by fit, acclimatized young men.

Adapted from Belding and Hatch, "Index for Evaluating Heat Stress in Terms of Resulting Physiologic Strains," Heating, Piping and Air Conditioning, 1955.

Example: Given Globe temperature = 105°, wet bulb = 80°, air speed = 70 fpm, and metabolic rate (*M*) = 100 kcal/m² = hr. From the small chart, find 4°F to be added to wet bulb to compensate for *M* above resting. Enter right side of chart at *T_{wb}* = 84 (80 + 4). Follow 84 *T_{wb}* line to intersection with 70 ft/min line. Connect this point with thread or straightedge to *T_g* = 105. Read *P₄SR* where this transverse line cuts air speed = 70; read *P₄SR* = 1.2. This would result in relatively mild physiologic strain, as the upper limit of tolerance for fit, young men is about *P₄SR* = 4.5.

Note that the chart is for men dressed in shorts. The index becomes less accurate in predicting strain as the upper level of tolerance is reached. Extrapolation to populations other than the standard "fit, young, acclimatized male" must be done with caution.

Wet Bulb Globe Temperature Index (WBGT). This index was developed originally to provide a convenient method to assess, quickly and with minimum of operator skills, conditions which posed threats of thermal overstrain among military personnel.²⁰ Because of its simplicity, it has been adopted as the principal index for a tentative Threshold Limit Value (TLV) for heat stress (Figure 31-8) by the American Conference of Governmental Industrial Hygienists (ACGIH)²¹ Fundamentally, the WBGT index is an algebraic approximation of the E.T. concept. As such, it has all the built-in limitations of the E.T., but has the advantage that wind velocity does not have to be measured for calculating its value.

WBGT is computed by appropriate weighting of Vernon Globe (*T_g*), dry bulb (*T_a*), and natural wet bulb (*T_{nwb}*) temperatures. The natural wet bulb is depressed below air temperature by evaporation resulting only from the natural motion of the ambient air, in contrast to the thermodynamic wet bulb, which is cooled by an artificially produced fast air stream, thus eliminating the air movement as a variable.

For outdoor use (in sunshine) the WBGT is computed:

$$\text{WBGT} = 0.7 (T_{nwb}) + 0.2 (T_g) + 0.1 (T_a).$$

For indoor use, the weighting becomes:

$$\text{WBGT} = 0.7 (T_{nwb}) + 0.3 (T_g).$$

Originally the interpretation of the levels of WBGT was for military activities of recruits in the following manner: above 30°C (86°F) WBGT, activities to be curtailed; above 31°C (88°F) WBGT, suspended entirely. For those in the latter stages of training, and hence acclimatized to

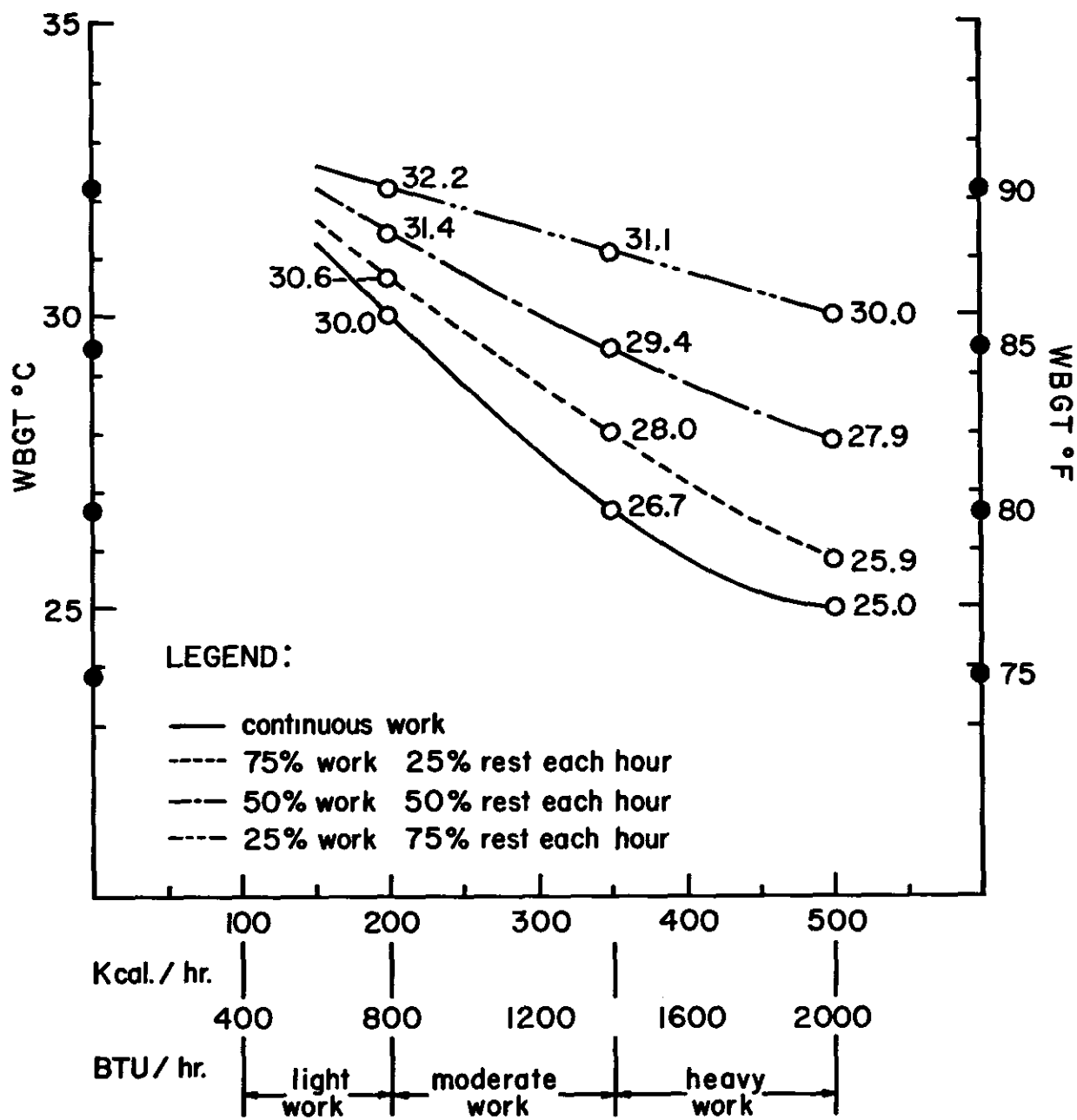

American Conference of Governmental Industrial Hygienists: Cincinnati, Ohio, 1971.

Figure 31-8. Permissible Heat Exposure Threshold Limit Value.

the heat, the levels are 31.0° and 32.2°C (88° and 90°F), respectively.²²

INTEGRATING INSTRUMENTS

Many attempts through the years have been made to devise instrumentation for assessing simultaneously the four environmental factors of air temperature, air speed, humidity, and radiant temperature.

One unit of this type, the modified Envirec was developed under a NIOSH contract. This instrument senses, indicates, and records on either magnetic tape or strip chart, the dry-bulb, thermodynamic wet-bulb and globe temperatures, and air velocity.

Another useful instrument, the WBGT integrator was developed under another NIOSH contract. This instrument senses and indicates dry-bulb, natural wet-bulb, and globe temperatures. It will also integrate these measurements and give a direct readout of the WBGT Index for either sunlit or inside conditions in accordance with the previously stated equations. Instruments for integrating two or more parameters into a single reading include the Vernon globe discussed above; the globe temperature is used directly in the Corrected Effective Temperature of Bedford.²³ Also, the globe temperature, in conjunction with natural wet

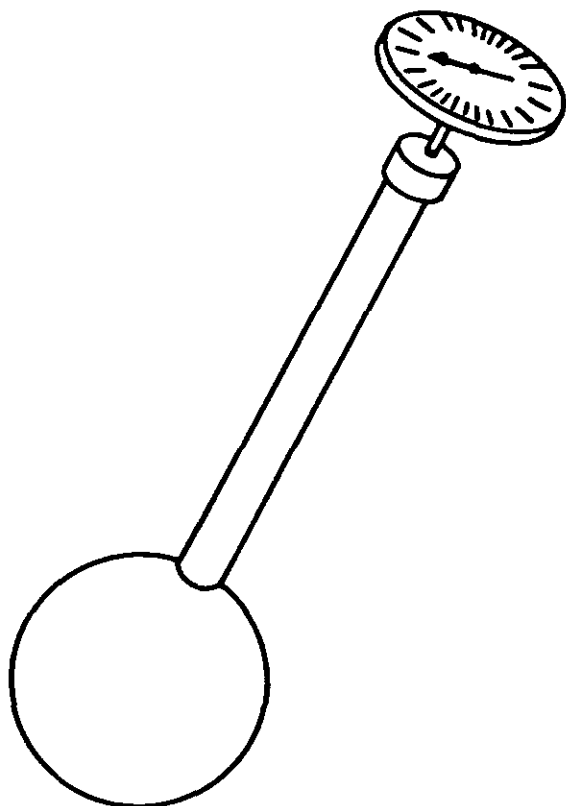

Botsford, J. H.: A wet globe thermometer for environmental heat measurement. *Amer. Ind. Hyg. Assoc. J.* 32:1-10, 1971.

Figure 31-9. Botsford — A Wet-Globe Instrument "Botsball".

bulb temperature, forms the basis of the WBGT Index discussed above.

More recently, Botsford²⁴ has developed a wet-globe instrument based on a small (6-cm diameter) copper sphere fitted with a black cotton wick and water reservoir (Figure 31-9). While the Vernon globe integrates the effects of air temperature, mean radiant temperature and air motion, wetting of the sphere introduces the fourth parameter. The device is maintained completely wet; man is not 100% wet unless E_{max} is low (see Chapter 38). The objective desired is that the stress readings obtained with the "Botsball" will correlate sufficiently well with physiologic strain that a given "Botsball" reading will have the same physiologic meaning in all combinations of environmental parameters. The instrument has not been available long enough to determine whether this objective will be achieved, although, replacing the WBGT with the "Botsball" would be desirable because of its simplicity.

The "Botsball" has a more advanced variant: the Botsball Cooling Capacity Meter. By addition of a heat source in the wet ball a constant 35°C surface temperature is maintained, to simulate human skin temperature. The associated electronics translate the current required to maintain this temperature into a meter readout, either in terms of Cooling Capacity Index, with a range from 0 to 100, or in terms of cooling power expressed in watts or Btu/hr. Battery-powered or 110 AC models are available (see Appendix for manufacturer). This sophistication exacts a price: an order of magnitude greater in cost and loss of simplicity. The physiological meaning of the cooling power values obtained with this instrument will have to be established before its applicability can be evaluated.

GUIDE FOR ASSESSING HEAT STRESS AND STRAIN

For purposes of validating the applicability of the ACGIH TLV for heat stress as an index for establishing thermal standards NIOSH sponsored a symposium. The participants of this symposium were asked to gather data in industry by using a standard methodology based on the TLV requirements and described in *the Guide for Assessing Heat Stress and Strains* as prepared by Minard and Belding.²⁵ Several industries agreed to follow the procedures outlined to provide a substantial body of data for evaluating the tentative TLV.

An instrumentation package consisting of the following instruments was recommended:

- 2 Bendix Hygro Thermographs Model 594; range +10° to +110°F
- 1 Bendix Psychron; range +30° to +120°F
- 1 Botsford Wet-Globe Thermometer
- 1 Six-inch Globe Thermometer; range about 50° to 212°F
- 1 Natural Wet Bulb Thermometer; range about 20° to 100°F
- 1 Hot Wire Anemometer for measurement of air velocity.

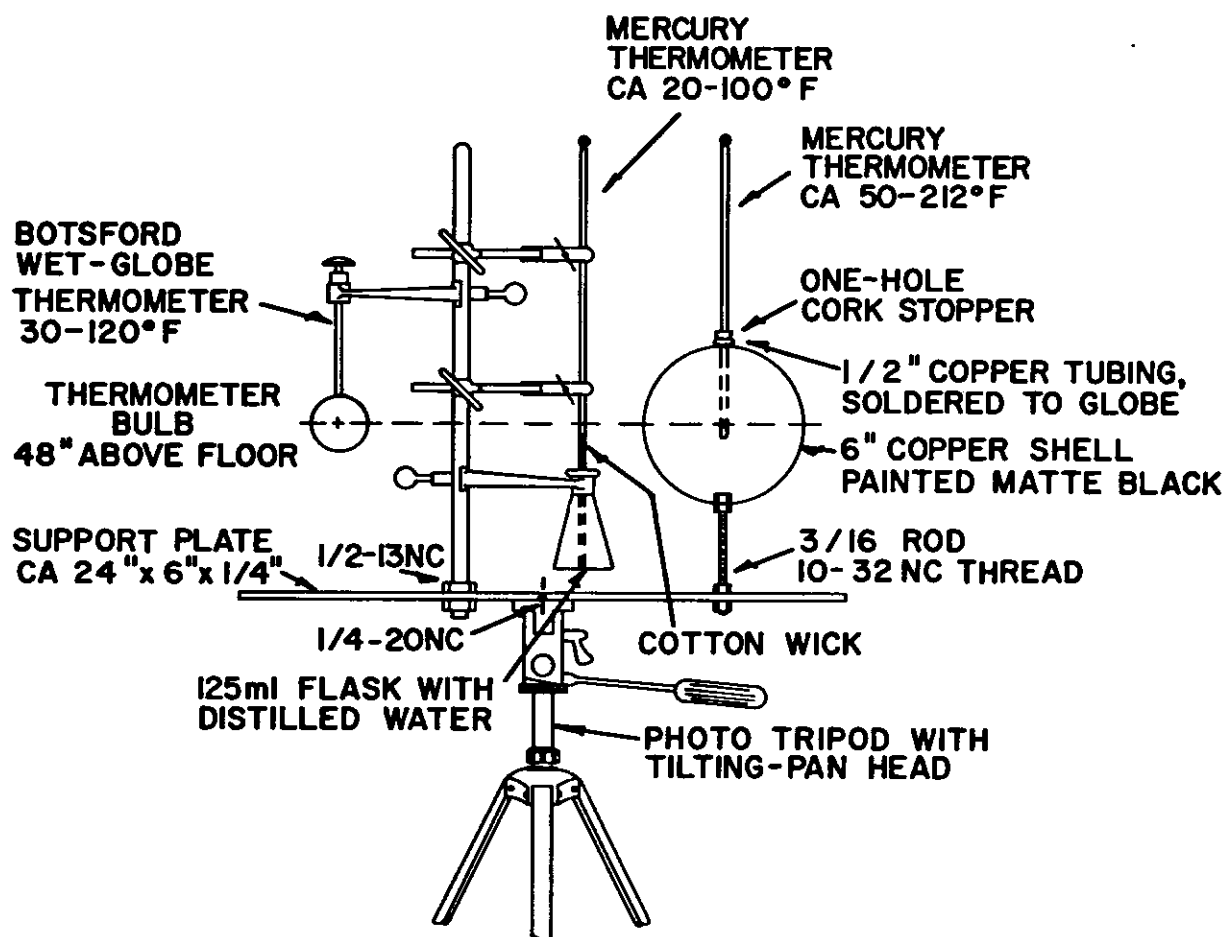

Minard, D., Belding, H. S.: Guide for Assessing Heat Stress and Strains. Industrial Health Foundation, Inc., Engineering Ser. Bull. No. 8-71, 1971.

Figure 31-10. Suggested Instrument Arrangement for Environmental Measurements.

One Hygro Thermograph records weather conditions outside the plant; the other is used as a reference monitoring station at a representative area within the plant.

The Vernon globe and natural wet bulb are mounted together on a tripod for stationing at selected work sites (Figure 31-10). The Botsball is also shown in this arrangement, to encourage comparability studies.

The psychrometer is used to take spot measurements of dry and (thermodynamic) wet bulb temperatures so that HSI or P_sSR may be calculated as well as WBGT. Sample data sheets are also provided so that information submitted by the diverse industries participating will be in comparable form. The outcome of the pooled data will provide validation and/or modification of the tentative TLV so that an effective and fair standard for heat stress may be written.

WINDCHILL INDEX

In recent years, it has become fashionable for weather reporters on radio and television to in-

clude the Windchill factor. This index was devised by Siple²⁶ to assess the relative discomfort of cold in relation to the air temperature and wind speed. The basic concept recognizes that convection is the most important single avenue of heat loss under cold conditions. The Windchill effect can be read from Table 31-2 where it is expressed in equivalent air temperatures which achieve the same rate of cooling at different wind velocities.

Example: Given $T_a = 45^\circ\text{F}$ and wind of 20 mph, read equivalent temperature = -27°F (at 0 mph). Note that equivalent temperatures are given for exposed flesh. Windchill values around 30°F are "cool;" -10°F , "cold;" below -40°F , exposed flesh freezes quickly and "travel is dangerous."

SUMMARY

The philosophy and development of indices for rating severity of the thermal environment has been discussed. The methods of assessment of the several parameters involved in the indices and guidance for their application and interpretation have been provided.

TABLE 31-2.
Equivalent Temperatures on Exposed Flesh at Varying Wind Velocities†

Temperature, °F	Wind velocity, mph								
	0	1	2	3	5	10	15	20	25
23	47.5	53.5	57	60	65	67	68	69.5	
-11	20	34.5	39	44.5	52	55	57	59	
-27	0	11	18.5	28	38	42.5	45	47	
-38	-23.5	-9	0	11	25	30.5	34	36	
-40*	-40*	-40	-16.5	-5	11	18	23	25	
		-40*	-40	-19	-2	6	11	14	
			-40*	-35	-15	-6	0	3	
				-40	-29	-18	-12	-8	
				-40*	-40	-30	-23	-18	
					-40*	-40	-35	-30	
						-40*	-40*	-40*	

†Adapted from Consolazio, Johnson and Pecora, *Physiologic Measurements of Metabolic Functions in Man*, McGraw-Hill Book Company, New York, 1963.

*Less than value.

References

- MACHLE, W. and T. F. HATCH. "Heat: Man's Exchange and Physiological Responses." *Physiol. Rev.* 27:200-227, 9650 Rockville Pike, Bethesda, Maryland 20014 (1947).
- HATCH, T. F. "Assessment of Heat Stress." In Hardy, J. D. (Ed.) *Temperature: Its Measurement and Control in Science and Industry*. Vol. 3, pt. 3, 307, Reinhold, New York (1963).
- POWELL, R. W. *Trans. Inst. Chem. Engrs.* (London), 18:36, (1940). Quoted by Nelson, N., Eichna, L. W., Horvath, S. M., Shelley, W. B., and Hatch, T. F.: "Thermal Exchanges of Man at High Temperatures." *Am. J. Physiol.* 151:626, 9650 Rockville Pike, Bethesda, Md. 20014 (1947).
- HAINES, G. F., Jr. and T. F. HATCH. "Industrial Heat Exposures—Evaluation and Control." Heating and Ventilating, London (Nov. 1952).
- TEUTSCH, W. B. "Basic Physics of Thermoelectric Effects." In Egli, P. H. (Ed.) *Thermoelectricity*, John Wiley, New York (1960).
- YAFFE, C. D., D. H. BYERS and A. D. HOSEY (Eds.) *Encyclopedia of Instrumentation for Industrial Hygiene*. Ann Arbor, University of Michigan (1956).
- HILL, L. "The Science of Ventilation and Open Air Treatment." Part I, *Med. Res. Coun. Spec. Rept.* No. 32, London (1919).
- MADISON, R. D. (Ed.) *Fan Engineering*, 5th ed., Buffalo Forge Co., Buffalo, New York (1949).
- MARVIN, C. F. *Psychrometric Tables for the Obtaining of Vapor Pressure, Relative Humidity, and Temperature of the Dew Point*. U.S. Dept. of Commerce, Weather Bureau, Washington, D. C. (1941).
- VERNON, H. M. "The Measurement of Radiant Heat in Relation to Human Comfort." *J. Physiol.* 70, Proc. 15, (1930).
- FANGER, P. O. *Thermal Comfort*. Danish Technical Press, Copenhagen (1970).
- GAGGE, A. P. "Effective Radiant Flux, an Independent Variable that Describes Thermal Radiation on Man." In Hardy, J. D., Gagge, A. P., and Stolwijk, J. A. J. (Eds.) *Physiological and Behavioral Temperature Regulation*. Chapter 4, Charles C. Thomas, Springfield, Ill. (1970).
- LONGLEY, M. Y., R. L. HARRIS, JR., and D. H. K. LEE. "Calculation of Complex Radiant Heat Load from Surrounding Radiator Surface Temperatures." *Amer. Indust. Hyg. Assoc. J.* 24:103-112, 66 South Miller Rd., Akron, Ohio (1963).
- BELDING, H. S. "The Search for a Universal Heat Stress Index." In Hardy, J. D., Gagge, A. P. and Stolwijk, J. A. J. (Eds.) *Physiological and Behavioral Temperature Regulation*. Chapter 14, Charles C. Thomas, Springfield, Ill. (1970).
- GIVONI, B. *Man, Climate, and Architecture*. Elsevier, London (1969).
- HOUGHTON, F. C. and C. P. Yaglou. "Determining Lines of Equal Comfort." *J. Am. Soc. Heat. and Vent. Engrs.* 29:165-176 (1923).
- BELDING, H. S. and T. F. HATCH. "Index for Evaluating Heat Stress in Terms of Resulting Physiological Strain." *Heat Pip. Air Condit.* 27:129, Keeney Pub. Co., 6 N. Michigan Ave., Chicago, Ill. (1955).
- McKARNs, J. S. and R. S. BRIEF. "Nomographs Give Refined Estimate of Heat Stress Index." *Heat Pip and Air Condit.* 38:113, Keeney Pub. Co., 6 N. Michigan Ave., Chicago, Ill. (1966).
- McARDLE, B., W. DUNHAM, H. E. HOLLING, W. S. S. LADELL, J. W. SCOTT, M. L. THOMSON, and J. S. WEINER. "The Prediction of the Physiological Effects of Warm and Hot Environments: the P_{SR} Index." *Med. Res. Coun. R. N. P. Rep.* 47:391, London (1947).
- YAGLOU, C. P. and D. MINARD. "Control of Heat Casualties at Military Training Centers." *Arch. Indust. Health* 16:302-316 (1957).
- TLV's. Threshold Limit Values for Chemical Substances and Physical Agents in the Workroom Environment with Intended Changes for 1972. Am. Confer. of Gov. Indust. Hygienists, 1014 Broadway, Cincinnati, Ohio (1972).
- MINARD, D., H. S. BELDING and J. R. KINGSTON. "Prevention of Heat Casualties." *J.A.M.A.* 165:1813-1818, 535 N. Dearborn, Chicago, Ill. (1957).

23. BEDFORD, T. "Environmental Warmth and Its Measurement." *Med. Res. Coun. War Memo No. 17*, London, HMSO (1946).
24. BOTSFORD, J. H. "A Wet Globe Thermometer for Environmental Heat Measurement." *A.I.H.A. J.* 32:1-10, 66 South Miller Rd., Akron, Ohio (1971).
25. MINARD, D. and H. S. BELDING. "Guide for Assessing Heat Stress and Strains." Industrial Health Foundation, Inc. Engineering Ser. Bull. No. 8-71 (1971).
26. SIPLE, P. A. and C. F. PASSEL. "Dry Atmospheric Cooling in Subfreezing Temperatures." *Proc. of the Am. Philosophical Society* 89:177-199 (1945).
27. LIND, A. R. "Tolerable Limits for Prolonged and Intermittent Exposures to Heat." In Hardy, J. D. (Ed.) *Temperature: Its Measurement and Control in Science and Industry*, Vol. 3, pt. 3, 337, Reinhold, New York (1963).
28. NIELSEN, M. "Die Degulation de Korpertemperatur bei Muskelarbeit." *Skand. Arch. Fur Physiologie* 79:193 (1938).
29. WYNDHAM, C. H., W. M. BOUWER, H. E. PATERSON and M. G. DEVINE. "Practical Aspects of Recent Physiological Studies in Witwatersrand Gold Mines." *J. Chem. Met. Min. Soc. So. Africa* 53:287 (1953).
30. *Criteria for a Recommended Standard Occupational Exposure to Hot Environments*. U.S. DHEW, HSMHA, NIOSH, HSM-72-10269. (1972).

NIOSH Note

The TLV diagram (Figure 31-8) combines three basic parameters: metabolic demands of the task (abscissa), an index of severity of the en-

vironment (WBGT), and percentage of time that the individual may be permitted to perform the task. For example, a task requiring light to moderate light work of 200 kcal/hr, could be performed continuously in environments up to about $WBGT=30^{\circ}C$, but only 25% of the time at $WBGT=34^{\circ}C$. A heavier task, say 400 kcal/hr, could be performed in environments of WBGT only up to about $26^{\circ}C$. This recognizes the role played by metabolic heat production in the heat balance equation (see Chapter 30); a simple method for assessing this parameter can be found in the TLV text.²¹ The basis for development of the TLV has been on the one hand the experiences of the services in protecting troops in training against heat illness,²² and on the other hand, consideration of combinations of environments which do not cause deep body temperatures (T_{core}) to rise above $38^{\circ}C$ ($100.4^{\circ}F$); these were determined by Lind and were identified as the "Prescriptive Zone."²³ As is evident in Figure 31-11, the equilibrium level of deep body temperature is dependent on the intensity of exercise, and independent of environment — up to a point. This effect was first noted by Nielson.²⁴ The family of curves suggest that at the inflection points the environmental stress has taxed the thermoregulatory system to its limit of thermal equilibrium at acceptable levels is no longer possible. The philosophy applied in the TLV is that the environmental

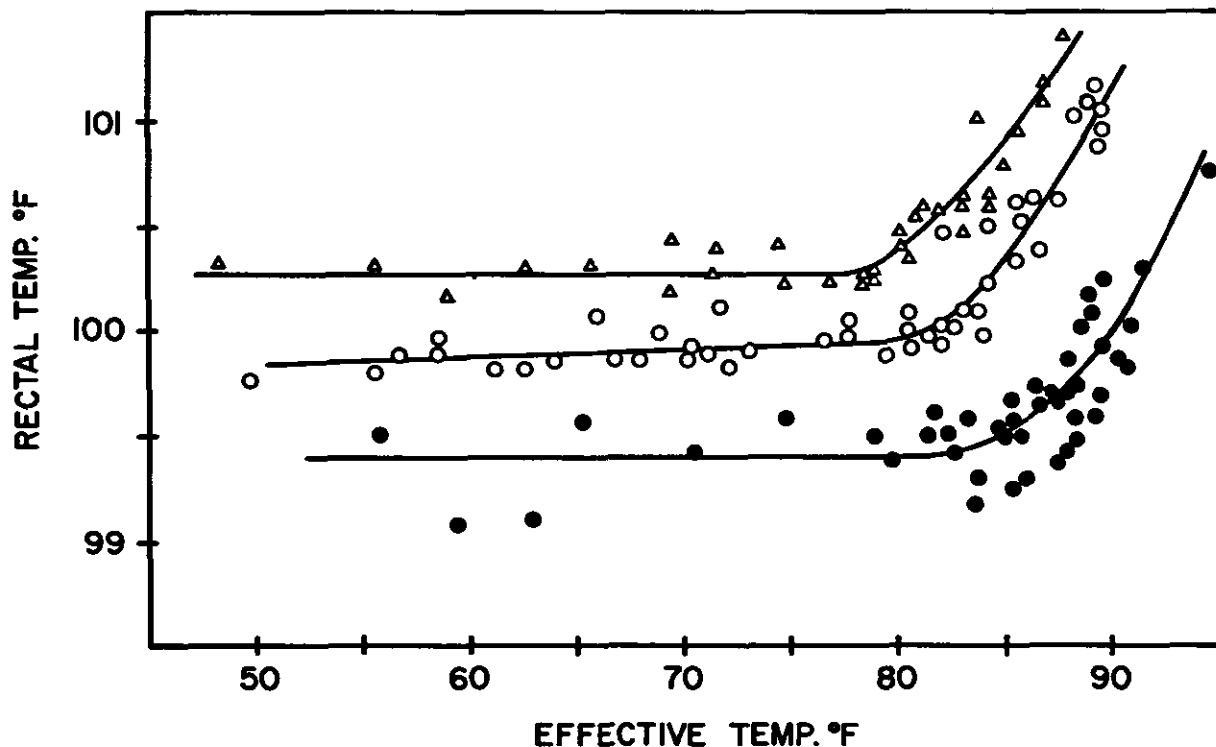

Lind, A. R.: Tolerable limits for prolonged and intermittent exposures to heat in Hardy, J. D. (ed): *Temperature: Its Measurement and Control in Science and Industry*. New York, Reinhold, 1963, vol. 3, p. 337.

Figure 31-11. Levels of Rectal Temperature during Continuous Work at 100 Kcal/m²/hr (●), 167 Kcal/m²/hr (○) or 233 Kcal/m²/hr (▲). At each rate of work there is a wide range of conditions in which the level of rectal temperature equilibrium is constant or nearly constant.

stress should not create a rise in deep body temperature over that in response to the work itself. This concept was also considered as most appropriate for the protection of the workers' health by an international scientific panel of the World Health Organization.

Others have argued that daily demands on the body for temperature increases above the Prescriptive Zone have no deleterious effects. Indeed, in some industrial uses the upper limits of thermal stress are based on elevations of body temperatures rather than on environmental parameters.²⁹

Application of the heat stress indices to hot industries has been attempted, not without some difficulties. Where the heat exposure is relatively uniform and lasts for prolonged periods e.g., military marching, driving an earthmoving vehicle, tending a weaving machine, the assessment of climatic and metabolic parameters is relatively simple. However, industries where duration of specific tasks may be measured in seconds, requiring maximal effort one minute, and minimal the next, and the environment may switch from intense radiant heat next to hot metal to ambient conditions of winter a few feet away, the assessment of the workers' actual heat exposure becomes quite cumbersome. Under such conditions, a detailed time and motion analysis of the work has to be performed and time weighted averages have to be calculated both for the climatic exposure and work load.

Research is currently underway at NIOSH to provide simpler and more accurate methods for assessing WBGT values, as well as the metabolic demand of the task.

APPENDIX

Sources of Environmental Instrumentation

Thermocouple wire: Driver-Harris, N.J., Leeds and Northrup, 4901 Stenton Ave., Philadelphia, Pa.; Revere Corp. of America, Wallingford, Conn.

Thermistor thermometer: Yellow Springs Instrument Company, Yellow Springs, Ohio (Manufacturer. Available only through scientific apparatus supply houses.)

Sling psychrometer: Taylor Instrument Company, 95 Ames St., Rochester, N.Y.

Motor-driven psychrometer: The Bendix Corp., Environmental Science Division, 1400 Taylor Ave., Baltimore, Md.; C. F. Casella Company, Ltd., Regent House, Fitzroy Square, London W.1, England.

Hair hygrometer, recording: The Bendix Corp., Environmental Science Division, 1400 Taylor Ave., Baltimore, Md.

Thermoanemometers: Alnor Instrument Co., 420 N. LaSalle St., Chicago, Ill.; Anemostat Corp. of America, P.O. Box 2128, Hartford, Conn.; Willson Products Div., The Electric Storage Battery Co., Reading, Pa.

Kata thermometer: C. F. Casella and Co., Ltd., Regent House, Fitzroy Square, London, W.1, England.

Vernon globe: (6-inch hemispherical spun copper blanks) Arthur Harris and Co., 212 N. Aberdeen St., Chicago, Ill.

Botsball thermometer: Howard Engineering Co., Box 3164, Bethlehem, Pa.

