



National Institute for Occupational Safety and Health
National Personal Protective Technology Laboratory
P.O. Box 18070
Pittsburgh, PA 15236

Procedure No. TEB-APR-STP-0039C	Revision: 2.1	Date: 3 February 2009
---------------------------------	---------------	-----------------------

DETERMINATION OF FORMALDEHYDE SERVICE LIFE TEST,
POWERED AIR-PURIFYING RESPIRATORS WITH CARTRIDGES
STANDARD TESTING PROCEDURE

1. PURPOSE

This test establishes the procedure for ensuring that the level of protection provided by powered air-purifying respirators (PAPR) with cartridges submitted for Approval, Extension of Approval, or examined during Certified Product Audits meet the formaldehyde service life requirements set forth in 42 CFR Part 84, Subpart G, Section 84.63(a)(c)(d), Subpart L, Section 84.190(b) and Subpart KK, Section 1157 (f).

2. GENERAL

This Standard Testing Procedure (STP) describes the Determination of Formaldehyde Service Life Test, Air-Purifying Respirators with Cartridges test in sufficient detail that a person knowledgeable in the appropriate technical field can select equipment with the necessary resolution, conduct the test, and determine whether or not the product passes the test.

3. EQUIPMENT / MATERIAL / REFERENCES

3.1. The list of necessary test equipment and materials follows:

- 3.1.1. Miller Nelson Research Model 401 Flow-Temperature-Humidity Control System (250 lpm) or equivalent. Air flow control accuracy is $\pm 2\%$ F.S. Temperature control accuracy is $\pm 1^\circ$ C. Humidity control accuracy is $\pm 3\%$ R.H.
- 3.1.2. Edge Tech Heated Dew Point Hygrometer with platinum mirror, Model DPS1 or equivalent. Accuracy is $\pm 0.2^\circ$ C, $\pm 0.5\%$ RH.
- 3.1.3. Interscan Corporation Model 1168 Formaldehyde Monitor 0-1999 ppb or equivalent. Accuracy $\pm 2.0\%$ of reading, ± 1 least significant digit.
- 3.1.4. Mass Flow Controllers, Brooks Instruments model series 5850S and 5853S with Read Out and Control Electronics, Brooks Instruments model 0154, variable flow rate depending on use. Accuracy is 0.7% set point & 0.2% FS.
- 3.1.5. American Meter Co. Dry Test Meter Model DTM-325.

Approvals: First Level	Second Level	Third Level	Fourth Level

- 3.1.6. Amersham Biosciences High Precision Pump, Model P-500 with reservoir. Flow rate range: 1 ml/hr to 400 ml/hr \pm 1.5% of setting.
 - 3.1.7. Electronic balance with an accuracy of 0.01grams.
 - 3.1.8. Miller Nelson Research, Model SV-2000 Vaporizer system or equivalent. Used for vaporizing formaldehyde solution.
 - 3.1.9. Kin-Tek Laboratories Inc. Model 491M Precision Gas Standards Generator.
 - 3.1.10. Permeation tubes of formaldehyde. Used for the calibration of formaldehyde detectors.
 - 3.1.11. "The Gilibrator", Primary Standard Airflow Calibrator or equivalent.
 - 3.1.12. Gilian Gil-Air-3 Sampling Pump, or equivalent.
 - 3.1.13. Graduated impinger, 25ml.
 - 3.1.14. Erlenmeyer flasks, 100 and 250 ml, beakers, 200 and 600 ml, polyethylene bottles, 500 ml, and flasks with ground glass joints, 1000 and 2000 ml.
 - 3.1.15. Pipets, 5 and 10 ml.
 - 3.1.16. Electronic balance with accuracy of 0.01 gram (g).
 - 3.1.17. Paraformaldehyde, purified grade \geq 95%.
 - 3.1.18. Sodium thiosulfate (granular) or 0.1N certified sodium thiosulfate solution.
 - 3.1.19. Starch, soluble potato, powder.
 - 3.1.20. Iodine, 0.1N certified solution.
 - 3.1.21. Sodium bisulfite, granular.
 - 3.1.22. Sodium carbonate, anhydrous powder.
 - 3.1.23. Glacial acetic acid.
 - 3.1.24. Hot plate with magnetic stirrer and stir bar.
 - 3.1.25. Media bottles, Pyrex Plus, 1000 ml.
- 3.2. Test fixture for mounting cartridges inside the test chamber. The test fixture used is specific to each manufacturer depending on how the cartridge is mounted to the facepiece. Some cartridges use a standard 40 mm male thread which mates with the test port in the chamber. In some cases the manufacturer is willing to provide a machined

adapter for mounting cartridges with unique threads. Alternatively, the cartridge adapters of the respirator are affixed by hot melt glue to a PVC pipe tee of appropriate size which mates with the test port. All adapters are checked for leak-tightness with soap solution.

- 3.3. The test chamber consisting of an approximately 12" x 12" x 7" air tight box, with 2 clamp type locks on the door opening lined with gasket material, and appropriate inlet, outlet and sampling ports. This fixture is not commercially available.
- 3.4. Refer to the following Work Instructions for further information on performing this test:
 TEB-RCT-APR-WI-1007 – Laboratory Safety Procedures for Formaldehyde Tests
 TEB-RCT-APR-WI-1107 – Calibration Procedures for Formaldehyde Tests
 TEB-RCT-APR-WI-1207 – Start-Up and Shut-Down Procedures for Formaldehyde Tests
 TEB-RCT-APR-WI-1407 – Reporting Results for Formaldehyde Tests

4. TESTING REQUIREMENTS AND CONDITIONS

- 4.1. Prior to beginning any testing, all measuring equipment to be used must have been calibrated in accordance with the testing laboratory's calibration procedure and schedule. All measuring equipment utilized for this testing must have been calibrated using a method traceable to the National Institute of Standards and Technology (NIST) when available.
- 4.2. Any laboratory using this procedure to supply certification test data as a contractor to NIOSH will be subject to the provisions of the NIOSH Supplier Qualification Program (SQP). This program is based on the tenets of *ISO/IEC 17025, the NIOSH Manual of Analytical Methods* and other NIOSH guidelines. An initial complete quality system audit and follow on audits are requirements of the program. Additional details of the Program and its requirements can be obtained directly from the Institute.*
 *Note 4.2 does not apply to Pretest data from applicants as required under 42 CFR 84.64.
- 4.3. Precision and accuracy (P&A) must be determined for each instrument in accordance with laboratory procedures and NIOSH/NPPTL guidance. Sound practice requires, under *NIOSH Manual of Analytical Methods*, demonstrating a tolerance range of expected data performance of a plus or minus 25% of a 95% confidence interval of the stated standard requirement. NIOSH/NPPTL P&A tolerance can be higher but not lower.
- 4.4. The precision and accuracy of this method was determined by validation testing of a single lot of commercially available multi-gas type cartridges. The results of these tests are shown in the table below.

TEST TYPE	MEAN SERVICE LIFE (MINUTES)	STD. DEV.
AS RECEIVED	142.10	8.77
EQUIL. 25% RH	202.79	5.53
EQUIL. 85% RH	203.06	15.22

- 4.5. Normal laboratory safety practices must be observed. Please refer to Material Safety Data Sheets and the current NIOSH Pittsburgh Health and Safety Program for the proper protection and care in handling, storing, and disposing of the chemicals used in this procedure.
- 4.6. Formaldehyde is considered a probable human carcinogen (Group B1) by EPA. Containers of paraformaldehyde and formaldehyde solution are typically used inside the laboratory fume hood. If there is a release of formaldehyde such as a spill outside the hood, sound an alarm, and any personnel in the laboratory should immediately exit from the building. Formaldehyde is considered hazardous waste by EPA and must be disposed of accordingly.
- 4.7. FORMALDEHYDE BENCH TEST FOR PAPR CARTRIDGES
- 4.7.1. Resistances and airflows for tight fitting PAPR will be taken before and after each test. Airflows only for loose fitting PAPR will be taken before and after each test. The standard testing procedures are described in TEB-APR-STP-003, TEB-APR-STP-007 and TEB-APR-STP-0012.
- 4.7.2. Test conditions as required by 42 CFR 84

SAMPLE	CONDITION	EQUILIBRATION CONDITIONS FOR 6 HOURS				TEST CONDITIONS				CONCENTRATION PPMV FORMALDEHYDE	
		TEMP.	AIRFLOW		R.H.	TEMP.	AIRFLOW		R.H.	TEST	BREAKTHROUGH
		° C	TIGHT FITTING	LOOSE FITTING	%	° C	TIGHT FITTING	LOOSE FITTING	%		
		LPM	LPM			LPM	LPM				
1-3	AS RECEIVED	NA	NA	NA	NA	25	115	170	50	100	1
4-5	EQUIL. 25% R.H.	25	115	170	25	25	115	170	25	100	1
6-7	EQUIL. 85% R.H.	25	115	170	85	25	115	170	85	100	1

Tolerances:

PARAMETER	TOLERANCE
25°C	± 2.5°C
115 LPM	± 1.0 LPM
170 LPM	± 1.0 LPM
25% R.H.	± 3% R.H.
50% R.H.	± 3% R.H.
85% R.H.	+0/-5% R.H.
100 ppmv	± 10%

NOTES: R.H. levels greater than 85% are difficult to maintain and may cause rapid degradation of service life.

Tolerance on accuracy of air flow rates exceeds specification on Miller Nelson control unit because flow rates are calibrated for every test. This improves the precision of the measurement and allows for the tighter tolerance on short-term drift.

4.7.3. All equilibrated cartridges will be resealed, kept in a position such that the direction of airflow would be horizontal, at room temperature, and testing shall begin within 18 hours.

4.8. It is particularly important to control the upstream temperature within the specified tolerance range because of the tendency of formaldehyde vapor to polymerize.

5. PROCEDURE

Note: Reference Section 3 for equipment, model numbers and manufacturers. Work Instructions are to be used in conjunction with standard NIOSH test apparatus.

5.1. Set up the test equipment as shown in Figure 1. The hygrometer sample line is located after the formaldehyde injection point. The paraformaldehyde - water solution will increase the RH and must be included in the RH measurement. The hygrometer has a platinum coated mirror to resist chemical attack.

5.2. Set up the Kin-Tek permeation system with the certified 1 ppm permeation tube for analyzer calibration.

5.2.1. Follow the instruction manual for the permeation system with regard to the proper dilution air flow rate, preconditioning of the permeation tube, and the correct temperature setting. Preconditioning and calibration may take 48-72 hours before testing of the respirator can begin.

5.2.2. Once the concentration has been determined from the permeation system, insert the intake tubing from the model 1168 formaldehyde monitor into the stream outlet of the permeation system.

5.2.3. Wait until the reading stabilizes, and adjust the span control to read the predetermined calculated concentration of the permeation tube.

5.3. Prepare solutions:

5.3.1. 10%-15% W/V Paraformaldehyde solution: In a 2000 ml beaker containing 1000 ml distilled water and a stirring bar, add 100-150 g paraformaldehyde. Stir and heat the solution to approximately 80-90°C using the heated magnetic stirrer. Do not overheat. Place a watch glass over the top of the beaker or cover with aluminum foil to prevent excessive water loss, or use a reflux system consisting of a flask with a ground glass joint connected to an Alihn condenser. Continue stirring and heating until the solution clarifies (about 8-12 hours w/o refluxing, 4-8 hours w/ refluxing). Filter the solution if not clear after 24 hours. Store in the Media Bottle (plastic coated bottle).

- 5.3.2. 1% starch: Weigh 1g starch and add to 100 ml boiling distilled water. Continue boiling until starch has dissolved. Discard when solution becomes cloudy.
- 5.3.3. 0.01N Iodine: Pipet 10 ml of 0.1N iodine into a 100 ml flask. Fill to mark with distilled water and invert 10-12 times to ensure complete mixing. Store in amber polyethylene bottle. Certified standard solution may also be used.
- 5.3.4. 1% Sodium Bisulfite: Weigh out 5g sodium bisulfite and dissolve in 500 ml distilled water. Store in polyethylene bottle.
- 5.3.5. Sodium Carbonate Buffer: Weigh out 40g sodium carbonate and transfer it to a 1 liter beaker containing a magnetic stir bar. Place the beaker on a magnetic stirrer. Add 250 ml of distilled water and stir until fully dissolved. Slowly add 10 ml glacial acetic acid while stirring. Dilute to 500 ml. Store in polyethylene bottle.
- 5.3.6. 0.1N Sodium Thiosulfate: Dissolve 24.82g sodium thiosulfate in 1 liter of distilled water. Certified standard solution may also be used.
- 5.4. Set the airflow to the required level for the sample being tested as per the test requirements in paragraph 4.7. Calibrate the total airflow, including any additional flow arising from hygrometer flow rates, from the test fixture using the dry test meter.
- 5.5. Make sure diverter valve in the system is diverting the challenge concentration airflow to discharge and not into the testing chamber.
- 5.6. Mount cartridge(s) onto test fixture and place in testing chamber.
- 5.7. Fill pump reservoir with formaldehyde solution from the bottle of solution. Insert needle from pump to septum tee in airline.
- 5.8. Set the high precision pump for delivery of calculated formaldehyde solution to obtain 100 ppmv at the testing airflow. See appendix 8.2.
- 5.9. Start flow from the high precision pump to the needle. Make sure formaldehyde is delivered to the heated vaporizing element. Establish the correct humidity and temperature for the sample being tested as per the test requirements in paragraph 4.7. Allow 30-40 minutes for equalization of concentration and RH.
- 5.10. Add 10 ml 1% sodium bisulfite solution to the impinger.
- 5.11. Attach Gil-Air 3 sampling pump to intake side of the impinger. Connect outlet side of bubbler to Gilibrator. Check 1 lpm flow of the pump pulling through the sodium bisulfite solution. This setting will be used to sample the formaldehyde concentration. Remove outlet side from Gilibrator.
- 5.12. Connect tubing from the sample side of the impinger into the Gil-Air pump and tubing from the inlet side of the gas bubbler into the test concentration.

- 5.13. Turn on sampling pump and sample for 30 minutes at 1 lpm.
- 5.14. Shut off vacuum pump and transfer the contents of the impinger into an Erlenmeyer flask. Rinse the impinger stem and body and transfer the washings to the flask.
- 5.15. Place a stir bar in the flask and place the flask on the magnetic stirrer. Begin stirring.
- 5.16. Add 1 ml starch solution.
- 5.17. Add 0.1N Iodine dropwise until solution is dark blue.
- 5.18. Add 0.1N sodium thiosulfate dropwise until blue color is gone indicating neutralization of the excess iodine.
- 5.19. Slowly add 0.01N iodine dropwise from a 50 ml. buret until the first appearance of a faint blue color.
- 5.20. Add 25 ml sodium carbonate buffer solution. The blue color should disappear if formaldehyde is present.
- 5.21. Record the initial buret reading of the 0.01N Iodine.
- 5.22. Slowly add the 0.01N Iodine until the appearance of a faint blue color.
- 5.23. Record the final buret reading. Calculate the challenge concentration of formaldehyde (see 8.2). Adjust syringe pump injection rate if necessary and repeat titration.
- 5.24. Note: Alternate direct reading methods for measuring the challenge concentration of formaldehyde in this test have been investigated but have been found to be unreliable.
- 5.25. Once the test concentration has been established, testing may begin.
- 5.26. Weigh the cartridge(s) and record the weight.
- 5.27. Measure initial inhalation and exhalation resistances of the cartridge(s) mounted on the facepiece as described in TEB-APR-STP-003 and TEB-APR-STP-007. Record values on the data sheet.
- 5.28. Record the initial weight of the formaldehyde solution bottle and start test.
- 5.29. Monitor and record challenge and breakthrough temperatures, challenge RH and breakthrough values and times throughout testing.
- 5.30. Run test until breakthrough of 1.0 ppmv is observed or minimum service life shown in section 6.2 is surpassed by 10%. At end of test, manually turn diverter valve to vent position. Weigh and record the final weight of the formaldehyde solution reservoir bottle.

- 5.31. Calculate and record the challenge concentration of formaldehyde (see attachment 8.2).
- 5.32. Dismount cartridge(s), weigh and record final weight, and take final inhalation and exhalation resistances as described in TEB-APR-STP-003 and TEB-APR-STP-007. Measurement of the final inhalation and exhalation resistances is required for certification and audit testing.
- 5.33. If there is another sample to test, repeat steps 5.6 – 5.31.
- 5.34. After all tests are completed for the shift, turn off syringe pump and heater, set temperature and humidity to zero on the Miller Nelson system and allow clean air to pass through the system for 30 minutes. Purge the breakthrough detector with clean air for 15 minutes.

6. PASS/FAIL CRITERIA

- 6.1. The requirement for passing this test is set forth in 42 CFR Part 84 Subpart G, Section 84.63(a)(c)(d), Subpart L, Section 84.190(b) and Subpart KK, Section 84.1157(f).
- 6.2. Minimum service life requirements for PAPR cartridges are shown below.

Cartridge	Test condition	Test atmosphere		Flowrate (l.p.m.) ²	Number of tests	Penetration ¹ (p.p.m.v.)	Minimum life (min.)
		Gas or vapor	Concentration (p.p.m.v.)				
Formaldehyde	As received	CH ₂ O	100	115 / 170	3	1.0	50
Formaldehyde	Equilibrated	CH ₂ O	100	115 / 170	4	1.0	50

¹Minimum life will be determined at the indicated penetration.

²Test flowrate shall be 115 lpm for tight fitting facepieces and 170 lpm for loose fitting facepieces.

7. RECORDS/TEST SHEETS

- 7.1. Record the test data in a format that shall be stored and retrievable.

8. ATTACHMENTS

- 8.1. Calculation for syringe pump injection rates
- 8.2. Calculation for formaldehyde concentration
- 8.3. Figure 1- Bench Top Set-Up
- 8.4. Data Sheet

8.1. Calculations for formaldehyde delivery – Amersham Syringe Pump

Calculations for theoretical formaldehyde injection rate

Molecular weight = 30.0 g/mol
 1 ppmv = 1.23 mg / m³ @ 25 °C ; 760 mm Hg
 Airflow (L/hr) = Airflow (L / min) x 60 min

$$\text{Injection rate (ml/hr)} = \frac{\text{Conc (ppmv)} \times 30.0 \text{ (g / mol)} \times \text{Airflow (L/hr)}}{24.45 \text{ L/mol} \times 10^6 \times 1.04 \text{ g/ml} \times (\text{Sol'n. concentration in g/ml})}$$

For 100 ppmv and 115 lpm, using 12.5% W/V solution:

$$= \frac{100 \times 30 \text{ g/mol} \times 115 \text{ Lpm} \times 60 \text{ minutes}}{24.45 \times 10^6 \times 1.04 \text{ g/ml} \times 0.125}$$

$$= 6.51 \text{ ml/hr}$$

For 100 ppmv and 170 lpm, using 12.5% W/V solution:

$$= \frac{100 \times 30 \text{ g/mol} \times 170 \text{ Lpm} \times 60 \text{ minutes}}{24.45 \times 10^6 \times 1.04 \text{ g/ml} \times 0.125}$$

$$= 9.63 \text{ ml/hr}$$

8.2. Calculation of Formaldehyde Concentration

The formaldehyde equivalent F_e is given by the formula:

$$F_e = \left(\frac{N_I}{.01} \right) \times 0.15 \text{ mg.}$$

Where N_I is the normality of the standardized iodine. This formula is based on the fact that the equivalent weight of formaldehyde is 15 g., which means that 1 ml. of 0.01N iodine is equivalent to 0.15 mg. of formaldehyde.

The amount of formaldehyde in the sample volume collected is given by the formula:

$$F_c = \text{final buret reading} - \text{initial buret reading} \times F_e \text{mg}$$

$$F_c = \text{total ml. .01 iodine used} \times 0.15 \text{ mg}$$

Formaldehyde concentration in ppmv is given by the following formula:

$$\text{ppmv} = \frac{F_c}{V} \times \frac{24.45}{MW} \times \frac{760}{P} \times \frac{T+273}{298} \times 10^3$$

Where:

- V = volume of sample collected (30 Lpm)
- MW = molecular weight formaldehyde (30.03 g/mole)
- P = pressure in mm of mercury in the lab
- T = temperature in °C of the lab

Assuming that T is equal to 25°C and p is equal to 760 mm mercury, the ppmv formula simplifies to:

$$\text{HCHO (ppmv)} = F_c \times 27.14 \text{ assuming volume of sample collected 30 liters}$$

$$\text{HCHO (ppmv)} = \text{ml. 0.01 Iodine used} \times 0.15 \text{ mg} \times 27.14$$

8.3. Figure 1- Bench Top Set-Up

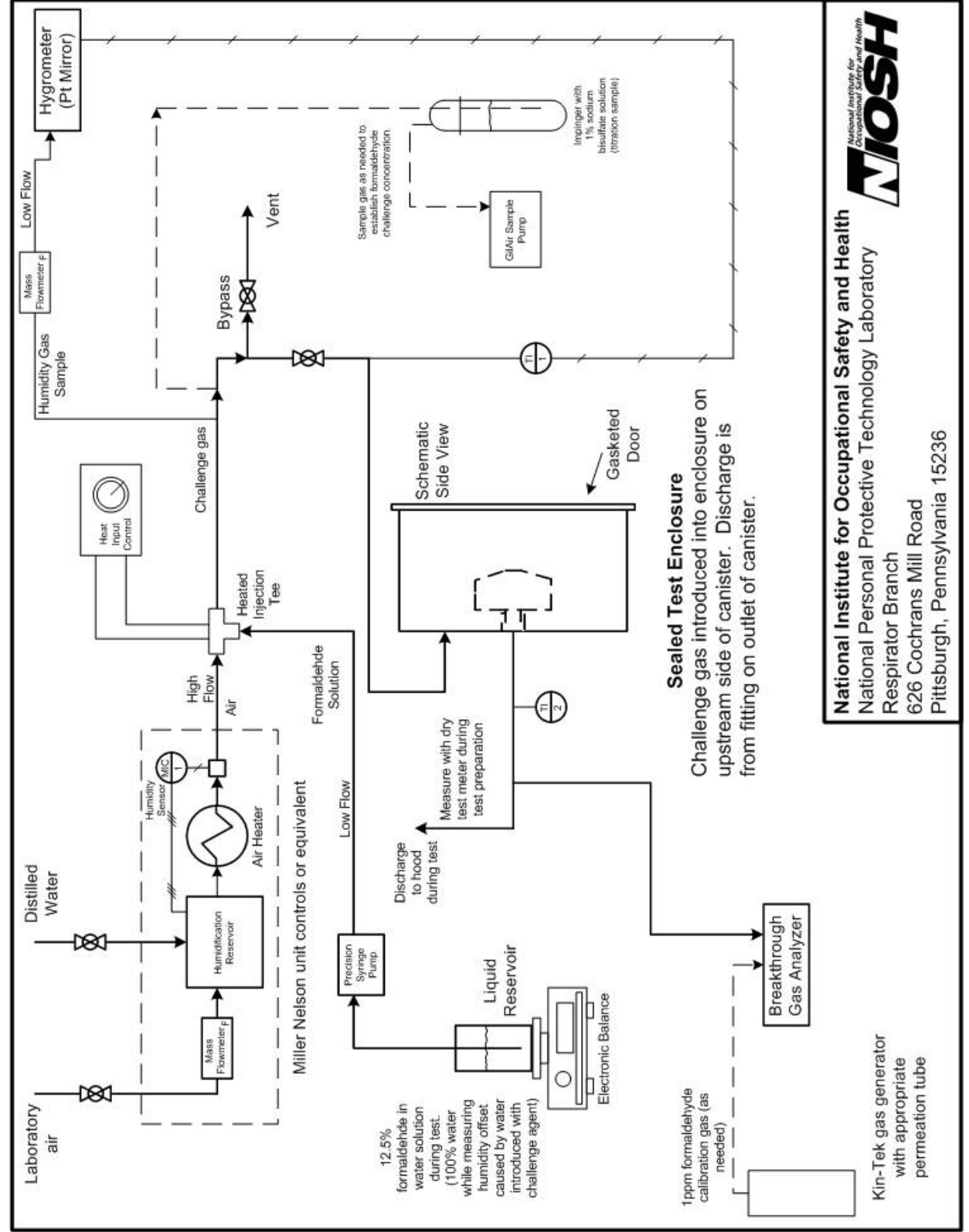

8.4. Data Sheet

 RB - RESPIRATOR CERTIFICATION TEAM GAS & VAPOR RESPIRATOR TEST DATA SHEET (Ref.33-48,50,62)										
Task Number: TN- _____					Gas Name: _____					STP No.: [_____]
Manufacturer: _____					Item Tested: _____					

RESISTANCE	Maximum Allowable Resistance (mm of H ₂ O)				Actual Resistance (mm of H ₂ O)				Result
	Inhalation		Exhalation		Inhalation		Exhalation		
			Initial		Initial	Final	Initial	Final	
1									
2									
3									
4									
5									
6									
7									
Overall Results: Pass _____ Fail _____ Comment: _____									

WEIGHTS AND AIRFLOWS	WEIGHTS (g)				AIRFLOW (Lpm)			
	Con'd			Conc. (ppmv)	Test Rate		(PAPR Only)	
					RH%	Lpm	Initial	Final
1								
2								
3								
4								
5								
6								
7								
Overall Results: Pass _____ Fail _____ Comment: _____								

DATA TABLE	Test Cond.	Final Time (min)	Leakage (ppmv)	Temperature (°C)				Corrected Time (min)
				Dns		eam		
				tream	Upstr			
1								
2								
3								
4								
5								
6								
7								
Overall Results: Pass _____ Fail _____ Comment: _____								
Was all testing equipment in calibration throughout all testing: Yes _____ No _____								
Signature: _____ Date: _____								

 <p>NIOSH <small>National Institute for Occupational Safety and Health</small> <i>RB - RESPIRATOR CERTIFICATION TEAM</i> <i>Page 2</i> <i>GAS & VAPOR RESPIRATOR TEST DATA SHEET (Ref.33-48,50,62)</i> STP No.: [_____] Task Number: TN- _____ Gas Name: _____ Manufacturer: _____ Item Tested: _____</p>
--

<p>Additional Comments:</p> <p style="text-align: center;">Signature: _____ Date: _____</p>

Revision History

Revision	Date	Reason for Revision
1.0	11 March 2002	Historic document
1.1	6 June 2005	Update header and format to reflect lab move from Morgantown, WV No changes to method
2.0	1 December 2008	Significant rewrite of RCT-APR-STP-0039. Changes affect form and provide clarification of technical content.
2.1	3 February 2009	Correction to test conditions as specified in table, section 4.7.2. RH values in rows two and three changed to 25% and 85 % respectively.