

USING ULTRASONIC ANEMOMETERS TO EVALUATE FACE VENTILATION CONDITIONS

E. Hall, National Institute for Occupational Safety and Health, Pittsburgh, PA
C. Taylor, National Institute for Occupational Safety and Health, Pittsburgh, PA
J. Chilton, National Institute for Occupational Safety and Health, Pittsburgh, PA

Abstract

The fact that methane ignitions continue to occur at the mining face indicates that monitoring with machine-mounted methanometers does not always indicate the presence of high methane concentrations. Methane concentrations at the face change quickly due to changes in airflow. By measuring these changes in airflow, it may be possible to predict changes in face methane levels more quickly. Currently there are no techniques or instruments to accurately measure airflow inby the mouth of the ventilation curtain or tubing. Tests conducted in the NIOSH ventilation test gallery compare the data provided by one-, two-, and three-axis ultrasonic anemometers. The effects of changes in airflow direction and turbulence on instrument readings are discussed, and guidelines are given for selecting the type of instruments to be used for monitoring airflow near the mining face.

Background

Fresh ventilation air is needed at the face to dilute and remove methane and dust liberated during the mining operation. Effective face ventilation requires that methane liberated at the face be diluted and removed quickly. At present, methane measurements are made at least once every 20 minutes at the face and continuously on the mining machine to determine methane concentrations. Airflow reaching the face is the only adequate control that can reduce face methane concentrations. As long as the methane concentrations do not exceed 1 percent, it is assumed that a sufficient air quantity is reaching the face.

The quantity of air that must be provided to each working face where coal is being cut, mined, drilled for blasting, or loaded, and the locations where ventilation measurements must be taken are specified by the following Federal regulations:

A minimum of 3000 cfm must reach each working face and this quantity must be measured "... at or near the end of the line curtain, ventilation tubing, or other ventilation control device." [30 CFR §75:325 (a) (1)]. For faces with exhaust ventilation, the mean entry air velocity must be measured "...at or near the inby end of the line curtain, ventilation tubing, or other ventilation control device." [30 CFR § 75:326].

Airflow measurements made at the inby end of the tubing or curtains are usually the only measurements available for estimating face airflow. However, past studies have shown that the air quantities measured at the inby end of the line curtain are not good estimates of how much air actually reaches the face (Thimons, et al., 1999). Airflow measurements made between the curtain or tubing and the face might give better estimates of how much intake air actually reaches the face. However, with current instruments and monitoring techniques, it is difficult to make accurate flow measurements.

For example, vane anemometers are normally used to measure airflow at the inby end of the ventilation curtain, but their ability to make accurate measurements is limited. The direction of the airflow behind the curtain is known and the vane anemometer is aligned with the flow direction to obtain an accurate air velocity reading. It is difficult, however, to align the anemometer at any location inby the curtain

because the flow direction is constantly changing. Smoke from chemical tubes can be used to estimate flow direction, but only where flow speeds and turbulence are relatively low (Taylor, et al., 2003). Currently, there are no anemometers approved for underground use that can accurately measure airflow velocities between the mouth of the curtain and at the face. Moreover, hand held anemometers cannot be used under unsupported roof.

This study evaluated techniques and instruments for making airflow readings inby the mouth of the ventilation curtain. The objective of the work was to test three different anemometers and identify how airflow properties in a simulated mine environment affect airflow measurements obtained with the three instruments. Based on the results of these tests, an anemometer design is recommended for measuring airflow near the mining face.

The instruments selected for these tests were one-, two-, and three-axis ultrasonic anemometers (see Figure 1). The three instruments were manufactured by the Gill Instruments, Ltd., Great Britain.¹ These instruments were chosen for use in this test program because they have the following features:

- High resolution at low velocities [0.01 m/sec (2 fpm)]
- Fast response (1 sample per second for these tests)
- Ability to provide data to calculate flow direction with respect to some reference point (two- and three axis only)
- Output functions that permit data to be transferred to a computer-based data acquisition system.



Figure 1. One-, two-, and three-axis ultrasonic anemometers.

The operation of an ultrasonic instrument is based on the principle that the speed of a sound pressure wave varies with the local air speed. The air velocity is calculated from measurements of air-pulse

¹ References to specific products do not imply endorsement by NIOSH.

transit times between sound transmitter and receiver. All three anemometers have a linear response to airflow and an absolute calibration that depends only on sensor spacing and transit time accuracy. The one-, two-, and three-axis ultrasonic anemometers use the pulse transit times to calculate the orthogonal flow components, which are designated U, V, and W (see Figure 2).

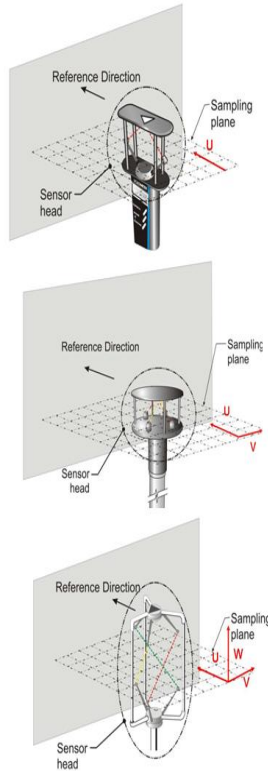

Figure 2. Comparison of flow components for three anemometers.

The one-axis instrument measures flow speed in the direction in which the instrument is pointed. The velocity calculated with the one-axis instrument is equal to the magnitude of the U flow component. With the instruments oriented vertically (see “Instrument Orientation” below) the U and V flow components are in a horizontal plane that is perpendicular to the sensor head. The W component is perpendicular to the horizontal plane.

Velocity measurements calculated with the two-axis anemometer are equal to:

$$\sqrt{U^2 + V^2}$$

Velocity measurements calculated with the three-axis anemometer are equal to:

$$\sqrt{U^2 + V^2 + W^2}$$

The two- and three-axis instruments measure airflow speed in the direction of the flow. Directions were calculated using the average values for the U and V flow components. The calculations were performed in an EXCEL spreadsheet using a modified form of the function ATAN2(U,V).

The angle of the flow directed above or below the horizontal UV plane was calculated using the three-axis data. The vertical angle is equal to: $\text{ATAN}(W/UV)$, where $UV = \sqrt{U^2 + V^2}$.

Test Procedures

Test Gallery

Testing was conducted in the NIOSH Pittsburgh Research Laboratory’s Ventilation Test Gallery (see Figure 3). The gallery is designed to simulate ventilation conditions in a working entry of an underground mine. One side of the empty gallery has the dimensions of a mining entry with a 2.2 m (7-ft) high roof and ribs 5 m (16½ ft) apart. Air enters the gallery through two windows, and an exhaust fan removes air from the gallery at a rate of 5.9 m³/s (12,500 cfm). The face of the mining entry was 35 ft in by the mouth of the blowing ventilation curtain. The curtain reaches from the floor to the roof and is supported by a wood frame that is constructed 0.6 m (2 ft) from the wall. The area behind the curtain was 0.7 by 2.2 m (2 ft by 7 ft). The air quantity behind the curtain is varied by opening or closing regulator doors. Three different airflows were used for tests conducted behind the curtain:

- Low flow [1 m/s (200 fpm)]
- Medium flow [2 m/s (400 fpm)]
- High flow [3 m/s (600 fpm)].

For all face tests the curtain flow was 2 m/s (400 fpm).

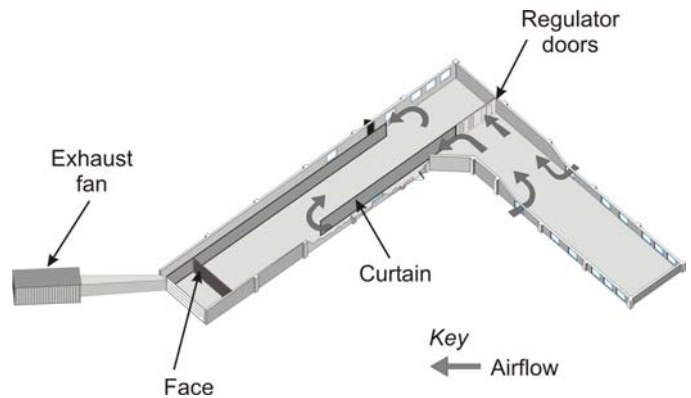

Figure 3. Pittsburgh Research Laboratory ventilation gallery.

Instrument Orientation

For all tests, the anemometers were attached to stands and oriented vertically. A bubble level was placed on top of the instrument to set and check vertical orientation. Instrument height was adjusted so that the center of the sensor head was 1.1 m or 3.5 ft from the floor (i.e. mid-way between the gallery roof and floor). For all tests the reference direction was toward the face. The instruments were rotated until the arrow printed on each instrument was pointed toward the face (see Figure 2).

To evaluate the effect of instrument rotation and tilt on velocity readings, data were initially taken with the instrument pointed toward the face. The amount of rotation, or yaw angle, is defined as the number of degrees in the horizontal plane that a vertically positioned instrument is rotated in a clockwise direction (see Figure 4). Plastic triangles with 30, 45, 60, and 90 degree angles were used to align the anemometer at the desired yaw angles. Airflow measurements were taken with the instrument directed toward the face (yaw angle = 0) and for yaw angles up to 90 degrees. To evaluate the effect of instrument tilt on velocity readings, an optical clinometer was used to set the anemometer at the desired tilt angle (accuracy +/- 5 degrees), which refers to the angle of instrument inclination (in degrees) from the vertical orientation (see Figure 5). Without rotating the sensor head, the instrument was tilted into the direction of the airflow. For the anemometer tilt, the angles used to measure velocities were 0, 30, 60 and 90 degrees.

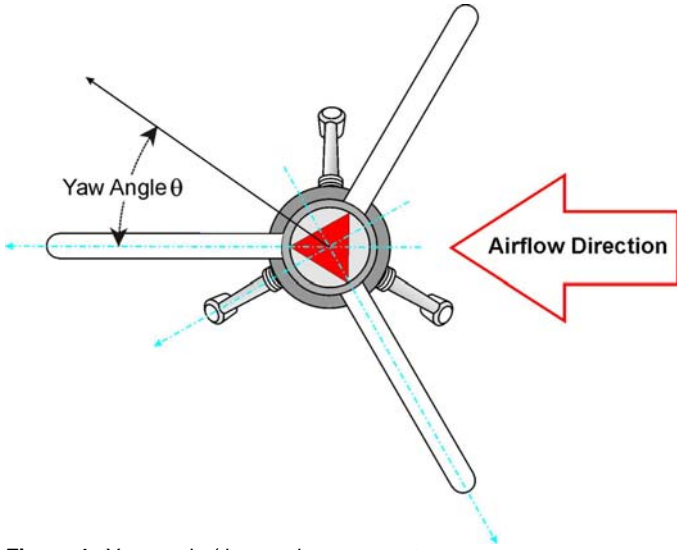

Figure 4. Yaw angle (three-axis anemometer).

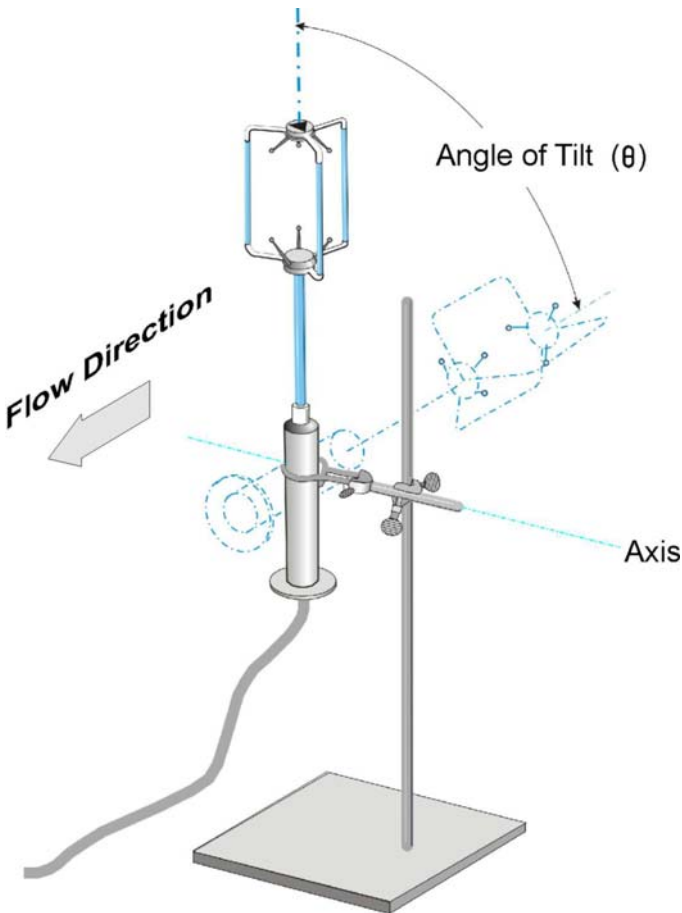

Figure 5. Tilt angle (three-axis anemometer).

Instrument Location

Instruments were tested individually behind the curtain at a location 6.1 m (20 ft) from the inby end of the curtain (see Figure 6). The sensor head was positioned mid-way between the curtain and the wall.

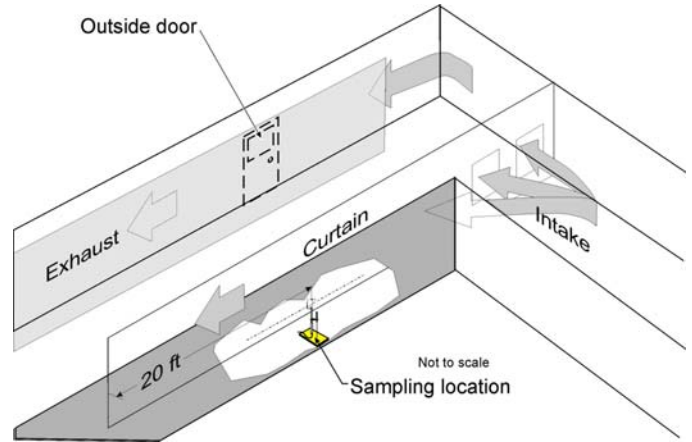

Figure 6. Sampling locations behind the curtain.

At the face, three instruments at a time were tested. Airflow measurements were made at each of the four locations (see Figure 7):

- 0.6 m (2 ft) from left wall (Position 1).
- 1.8 m (6 ft) from left wall, (Position 2).
- 1.8 m (6 ft) from right wall and (Position 3).
- 0.6 m (2 ft) from the right wall (Position 4).

All sampling locations were 0.6 m (2 ft) from the face.

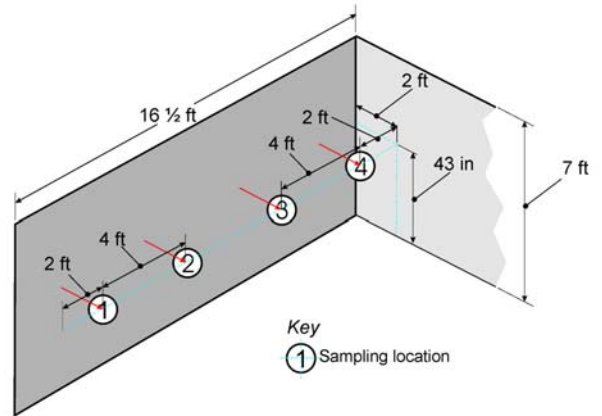

Figure 7. Sampling locations at the face.

Data Acquisition

ANEMVENT 2003, a computer software program written by NIOSH (Taylor et al., 2005), was used to record three-axis instrument data. Windcom software (provided by the instrument manufacturer) was used to record two-axis instrument data and Hyperterminal software (Hilgraeve, Inc.) was used to record data from the one-axis instrument. All data were transferred to Microsoft Excel spreadsheets for analysis.

The data sampling rate for all tests with each instrument was one sample/second, and the duration of each test was three minutes. The average reading for each test was calculated for the 180 data points. Each test behind the curtain was repeated once and the results averaged. Tests at the face were repeated six times and the results averaged.

Results

Flows Behind the Curtain

Air velocity readings were compared for the three instruments. When oriented vertically the instrument readings differed by less than 3.5 pct (see Figure 8).

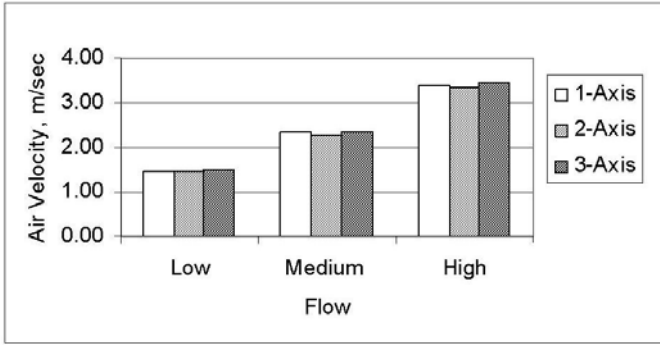

Figure 8. Comparison of flow velocities behind the curtain.

The effects of yaw and tilt angles on instrument readings are shown in Figures 9 and 10. Increasing the yaw angle had little effect on velocity readings for the two- and three-axis instruments. Furthermore, readings measured with the one-axis instrument decreased as the yaw angle increased.

Velocity readings for all three instruments decreased as tilt angle increased, but each instrument responded differently at different angles.

Across the Face

Flow velocities measured at the face with the two- and three-axis instruments were comparable, but the differences were greater than those measured behind the curtain (8 to 10 pct at the face versus 3.5 pct behind the curtain), as shown in Figure 11. At all four face sampling locations, the one-axis readings were much lower than readings obtained with the two- and three-axis instruments. At location 4 the one-axis readings were negative, indicating the flow direction was away from the face.

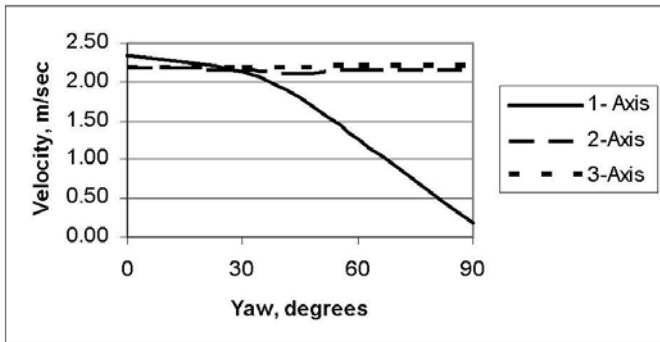

Figure 9. Effect of yaw angle on measured velocities.

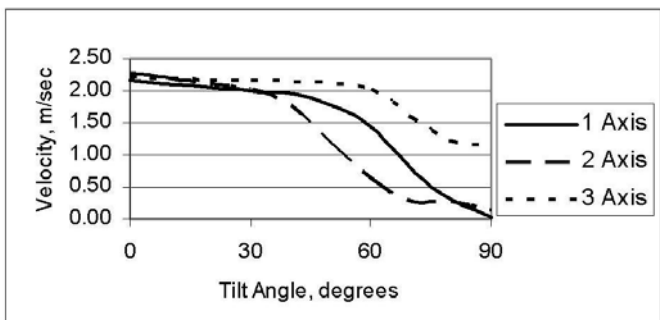

Figure 10. Effect of tile angle on measured velocities.

Discussion

Tests were conducted to compare the performance of one-, two-, and three-axis ultrasonic anemometers at different sampling locations (curtain and face) and instrument orientations. When exposed to the same airflow behind the curtain, all the instruments gave similar

velocity readings. To obtain the same readings the instruments were:

- Oriented vertically
- Exposed to the same airflow (placed at the same sampling location)
- Oriented in the same direction as the airflow.

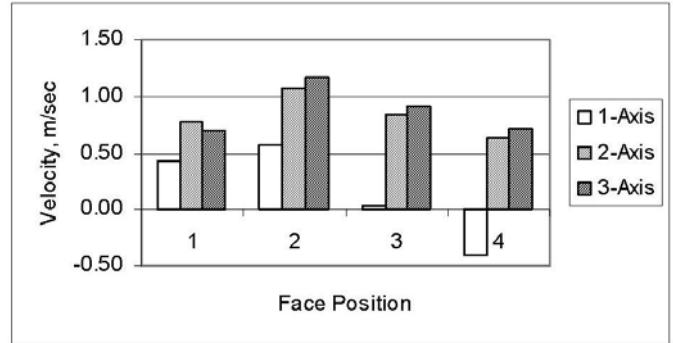

Figure 11. Comparison of flow velocities at face sampling locations.

The instruments were aligned visually with the airflow, and some of the variation between readings was probably due to improper alignment. Alignment of the instrument with the airflow is particularly important with the one-axis instrument.

One-axis readings decreased as the yaw angle increased because velocities, with this instrument, are measured only in the direction of flow. The decrease in the measured velocity can be estimated by the cosine of the yaw angle (See Figure 12).

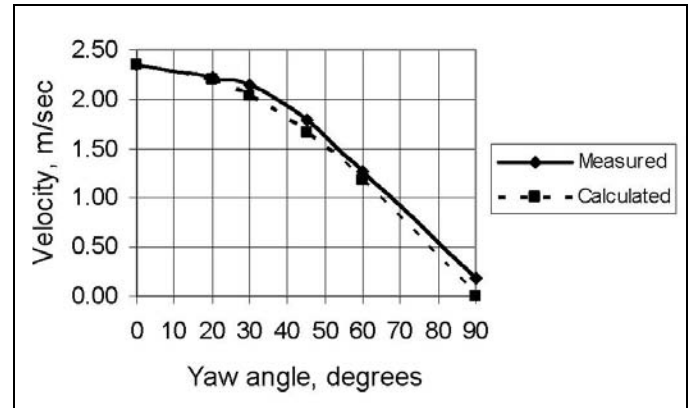

Figure 12. Measured and calculated function of the cosine angle of flow due to yaw angle.

The effects due to yaw angle on one-axis measurements are relatively small below angles of 20 degrees. These results are similar to results obtained by a rotating vane anemometer, which is also a one-axis instrument (Boshhov, 1955). The 2- and 3-axis instrument readings were unaffected by changes in yaw angle because both measure velocity in the direction of flow.

All instrument velocity measurements decreased with increasing tilt angle, but the responses were different (Figure 10). For the two-axis instrument, velocities decreased faster above 40 degrees of tilt angle due to the structure of the anemometer. When in the vertical position, the air flow can pass through the sensor head. When tilted, the air must move around the support structure of the sensor head before passing over the sensor head.

As the three-axis instrument is tilted, the value of U decreases. Velocity in the direction of flow is calculated by:

$$Velocity = \sqrt{U^2 + W^2}$$

The measured velocity is relatively constant until approximately

60 degrees. The change in velocity measured above 60 degrees is due to the structure of the anemometer. The three spars that hold the sensor probes in place are attached to the body of the anemometer located just below the sensor head and to a round connector at the top of the sensor head. At tilt angles greater than 60 degrees, the body of the anemometer and the upper spar connector interfere with flow over the sensor head (Taylor et al., 2004). The physical structures of the two- and three- axis instruments were different and had a different effect on tilt angle response.

Airflow readings behind the curtain differed by less than 3.5 percent, while the differences at the face were greater. These differences were due to how air flowed over the sensor heads behind the curtain versus at the face. For the locations sampled at the face, the one-axis readings were much different than readings obtained with the two- and three-axis instruments. This was due to the orientation of the one-axis anemometer and the direction of the airflow. Flow directions, measured at the four face locations with the three-axis instrument, are shown in Figure 13. The lengths of the arrows are proportional to the air speed.

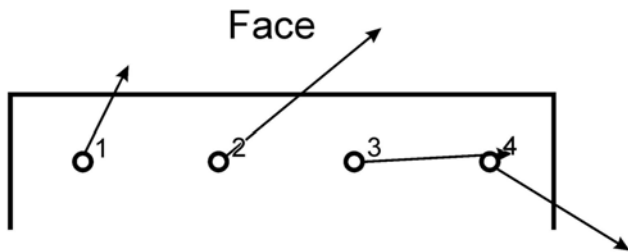

Figure 13. Flow directions at four face sampling locations.

Both the two- and three-axis instruments measured velocity in the direction of the airflow. The variations in the flow readings were small at locations 2, 3, and 4, but greater than what was measured behind the curtain (e.g. less than 3 pct behind the curtain and 8 to 10 pct at the face).

Initially, it was unclear why the difference in the readings for the two- and three-axis instruments was greater at the face than behind the curtain. It was assumed that air flow patterns in the gallery were primarily in horizontal planes. Measurements with the three-axis anemometer behind the curtain showed the average vertical angle of flow above or below the horizontal sampling plane was no greater than 3 degrees. However, at the face, the average angle varied from 3 to 8 degrees for the four positions. In addition, the standard deviation for the individual angle measurements was less than 2 degrees behind the curtain but was 8 to 24 degrees at face sampling locations. The amount of turbulence indicated by the higher standard deviation (Hinze, 1975) is probably a significant factor affecting differences in two- and three-axis readings.

Another likely factor is the difference in the measurement area between the sensor transducers due to the physical structures of the two- and three-axis sensor head. The areas defined by the ultrasonic pulse paths through which the air flows are sampled are different for the two and three axis instruments. The directional velocities and average flows measured across areas of various sizes will differ. Since the flow was more uniform in the area behind the curtain, the differences across the two- and three-axis instruments in this location will be smaller.

Conclusions

This study investigated airflow measurements made in a simulated mine environment using three different ultrasonic anemometers. The difference between the three instruments was the number of orthogonal components of flow (U, V, and W) used to calculate the flow velocity. The one-axis instrument measures flow in one direction, the direction of instrument orientation. The two-axis instrument measures flow velocity in a plane defined by the U and V

flow components in a direction relative to a reference direction. The three-axis instrument measures flow in a three-dimensional space defined by the U, V, and W components of flow.

After orienting the three instruments vertically and in the direction of the airflow at the same location behind a blowing curtain, the airflow measurements obtained with the three instruments were comparable (differences were less than 3.5 pct). At the four sampling locations at the face:

- The one-axis instrument gave lower airflow measurements
- The velocity differences between two- and three-axis instrument readings were greater than readings behind the curtain.

Differences between two- and three-axis instrument readings were the result of high variability in air flows at the face and the physical size and shape of the sensor heads.

The test results show that when airflow direction is known and the anemometer is properly aligned, such as behind the curtain, accurate airflow readings can be taken with one-, two- or three-axis ultrasonic anemometers or vane anemometers. However, at locations between the mouth of the curtain and the face, two- or three-axis anemometers are required to accurately measure flow. This is primarily due to changing of airflow direction that is difficult to determine without a two- or three-axis instrument.

A comparison of two- and three-axis instrument performance showed that differences in the readings were greater at the face than behind the curtain. Higher flow turbulence at the face is believed to be primarily responsible for the greater differences.

The one-axis anemometer has the same limitations as the current standard vane anemometer, which is dependent upon orientation with respect to airflow. Further ventilation gallery testing will be conducted with the two- and three-axis anemometers to evaluate the effects of sampling location on measured velocities. It is unlikely that the three-axis design could be modified for making underground airflow measurements because it is too easily deformed by physical stress. However, it may be possible to adapt the two-axis design for underground use because of its size and a more robust design. The two-axis design could be used to monitor flow continuously almost anywhere underground, including near a working face or at locations outby the mining section.

References

1. Boshkov, S and MT Wayne (1955), "Errors in Underground Air Measurements", *Mining Engineering*, November, pp. 1047-1053.
2. Hinze, JO (1975), "Turbulence", McGraw Hill, 2nd Edition.
3. Taylor, CD, JE Chilton, LJ McWilliams, and M Senk (2004), "Evaluating Factors Affecting the Performance of Three Axis Ultrasonic Anemometers", *Proceedings of the Tenth US/North American Mine Ventilation Symposium*, Anchorage, Alaska, May 16-19, pp. 465-470
4. Taylor, CD, RJ Timko, M Senk, and AD Lusin (2003), "Measurement of Airflow in a Simulated Underground Mine Environment Using an Ultrasonic Anemometer", *Pre-prints 2003 Annual SME Meeting*, Cincinnati, Ohio, February 24-26.
5. Taylor, CD, RJ Timko, ED Thimons, and T Mal (2005), "Using Ultrasonic Anemometers to Evaluate Factors Affecting Face Ventilation Effectiveness", *Pre-prints 2005 Annual SME Meeting*, Salt Lake City, UT, February 28-March 2.
6. Code of Federal Regulations, Title 30, Mineral Resources, Part 75, www.msha.gov/30CFR.htm