

Roof Bolt Response to Shear Stress: Laboratory Analysis

Ed McHugh, Geologist
Steve Signer, Mining Engineer
National Institute for Occupational Health and Safety
Spokane Research Laboratory
Spokane, WA

ABSTRACT

Recent studies by researchers from the National Institute for Occupational Safety and Health indicate that shear loading contributes significantly to failure of bolts used for rock reinforcement in coal mine roofs. Laboratory tests on 17 bolts were conducted to study the behavior of roof bolts subjected to shear loading over a range of axial bolt loads. Fourteen strain gauges were attached to each bolt to measure axial and bending loads at seven locations along its length. The instrumented bolts were grouted through two high-strength concrete blocks, and axial tension was applied to as much as 75% of yield strength. With the block interface acting as a failure plane, shear loads were applied to the blocks at a constant rate of displacement to the ultimate strength of the bolts. The tests characterized the relationship of axial bolt loads to shear forces across a rock bedding plane and measured the distribution of axial and bending strain along the length of the bolts. These results will improve the selection of roof reinforcement in mine areas where high shear stresses are present, thus improving the safety of miners working in these areas.

INTRODUCTION

Resin-grouted roof bolts are standard elements in ground control systems at most underground coal mines in North America. In general, sagging of the mine roof and yielding of pillars result in vertical and horizontal stresses in the mine roof, imparting both axial and shear forces on roof bolts. Combined tensile and shear forces are at times sufficient to cause failure of the bolts. Mine Safety and Health Administration (MSHA) statistics show that more than 400 miners are injured in roof and rib falls annually; in the 5 years from 1994 through 1998, 53 miners died in such accidents. Twenty-two fatalities occurred in underground coal mines during 1998; of that number, 14 deaths (64%) resulted from falls of ground.

The Spokane Research Laboratory (SRL), a division of the National Institute for Occupational Safety and Health, is

conducting research on roof bolt loading to reduce support failure and subsequent ground falls. The intent of this study was to examine the effects of shear forces on rock bolts.

Early laboratory shear tests were conducted by Haas et al. (1976) using various bolt types and anchors in blocks of limestone and shale; they found that resistance to shear stress was increased about 3.7 times when fully grouted bolts were used to secure a natural fracture. Radcliffe and Stateham (1980) installed instrumented bolts in a Colorado coal mine. Each bolt had three pairs of strain gauges, one pair at each end of the bolt and one in the center. Most of the bolts exhibited bending at the center gauges, and about a third of the bolts were subjected to strain beyond the yield point of the steel. Haas (1981) applied laboratory shear test data to estimate safety factors for reinforcing a natural shear plane with grouted bolts. Turner (1987) found that appreciable opening of fractures prior to shear movements resulted in double bends and failure of rock bolts by tension. Bolts across unopened fractures had been actually cut (guillotined) during rock bursts. Pellet et al. (1996) related theoretical and experimental analyses of rock bolt shear strength and found that bolts installed perpendicular to a joint plane allowed the greatest displacement along the joint before failure, but that displacement at failure decreased rapidly as the angle between the bolt and joint plane decreased. They also found that harder rock led to bolt failure at smaller displacements. Goris et al. (1996) used essentially the same procedures as followed in this study to conduct direct-shear tests on conventional steel cable bolts. Signer and Lewis (1998) used axial loads on instrumented bolts in an underground coal mine as evidence of shear stresses that contributed to roof bolt failure.

Methods

The bolts tested were 58.4-cm-long (23-in), standard grade 60, Dywidag No. 7 Threadbars.¹ Continuous, rolled-in threadlike de-

¹The mention of specific products or manufacturers does not imply endorsement by the National Institute for Occupational Safety and Health.

formation along the length of a bolt allows it to be tensioned to its full yield strength through the use of nuts and couplers. A 6.4-mm-wide by 3.2-mm-deep (0.25 by 0.125 in) slot was milled along the smooth sides of each bolt. After milling, the bolt's cross-sectional area was 3.47 cm² (0.5375 in²), and section modulus was 0.816 cm⁴ (0.196 in⁴). Tests have shown that the slotting process reduces axial bolt strength by approximately 10% (Signer et al., 1997, p. 184). Seven strain gauges were installed along each side of the bolt as described by Johnston and Cox (1993). The strain gauges were arrayed so that one pair of gauges was at the center and additional pairs of gauges were at 5, 10, 20 cm (2, 4, and 8 in) from the center in each direction (figure 1). The instrumented bolts were calibrated in a uniaxial test machine to correlate voltage change to load change at bolt load levels below the yield point of the steel. Voltage readings were also converted to strain according to the equation—

$$\epsilon = 4\Delta V / GF \cdot EV \quad (1)$$

where ΔV = change in voltage,
 GF = gauge factor (2.075),
 and EV = excitation voltage (5 V).

The instrumented bolts were installed in pairs of 29-cm (11.5-in) square concrete blocks made from a fine sand-cement mix having an average 28-day compressive strength of 85.5 MPa (12,400 psi). The first block of the pair was cast by pouring the mix in a steel mold with a flat aluminum bottom to create a smooth shearing surface of 780 cm² (121 in²). A 2.86-cm (1.125-in) in diameter rod was centered in the mold before casting. The rod was removed after about 24 hours to provide a hole through the block for placement of the bolt to be tested. A recess about 8.9 cm (3.5 in) square and 8.9 cm deep was also cast into the top of each block to allow room for a plate and a nut, and to permit access to the end of the bolt when it was to be tensioned. The second block of the pair was cast using the bottom surface of the previously cast block to create a matched shearing surface. This block was also cast with a centered rod and a bolt-end recess.

The instrumented bolt to be tested was positioned through the aligned holes so that the strain gauges faced one side of the block assembly. A polyester resin anchoring grout (Fosroc Anchortite) was used to assure direct contact between the bolt and the concrete block. The grout has an unconfined compressive strength of at least 69 MPa (10,000 psi) and a setting time of about 60 min. The bolt was coupled through an A-frame extension to an 18-mt (20-ton) hydraulic jack and tensioned against a plate and a nut on one end of the bolt. A through-socket and wrench were then used to tighten a nut at the other end to a specified torque to retain the desired load.

After the grout had set, the block assembly was placed in steel shear boxes and oriented so that the gauges faced in the direction of shear displacement. The shear boxes allow a 0.63-cm (0.25-in) gap between the walls of each box and the surfaces of the blocks. This annular space around the blocks was filled with quick-curing gypsum cement, which has a compressive strength of about 28 MPa (4,000 psi), to ensure complete contact with the shear boxes.

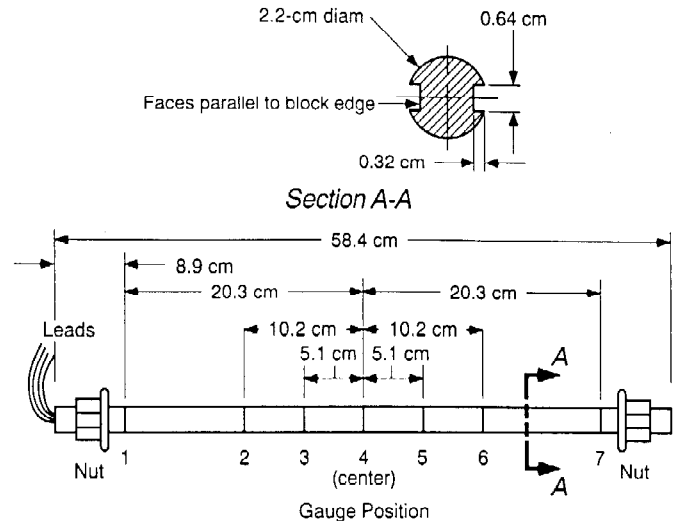

Figure 1.—Instrumented roof bolt

Testing

Tests were conducted in a Gilmore direct-shear, materials-testing machine. This high-pressure hydraulic test frame has a capacity of 1,334-kN (300,000 lbf) along both the shear and normal axes. The shear box assembly with the concrete blocks and a tensioned, instrumented bolt was placed on rollers in the test frame with the bolt aligned to the normal (vertical) axis. Figure 2 shows the shear box assembly ready for testing. An MTS TestStar II control system allowed for computer management of test parameters through templates that determined loads, displacement, and rates in both the shear and normal directions. For this series of tests, a constant load of 8.90 kN (2,000 lbf) was applied along the normal axis of the block assembly, principally to help maintain the position of the box assembly during shearing.

During the test, the upper box was held immobile against a backstop in the frame while shear loads were applied at a constant displacement rate of 0.55 mm/min (0.0216 in/min) on the lower box. With the steel shear boxes in the test frame, maximum shear displacement for the machine was 4.6 cm (1.8 in). Applied load and displacement data were collected at 3-sec intervals within the TestStar system and at 15-sec intervals with an external datalogger (Campbell Scientific Model 21X-QM). The datalogger also collected information from the array of strain gauges on the instrumented bolt.

SHEAR TEST DATA

The program was designed to test 15 instrumented bolts pretensioned at five different axial bolt loads. An initial test on an uninstrumented bolt was conducted to establish reasonable shear displacement rates, load ranges, and applied-load sampling intervals. Two tests on instrumented bolts were added to establish strain gauge sampling methods and intervals. Strain gauge data

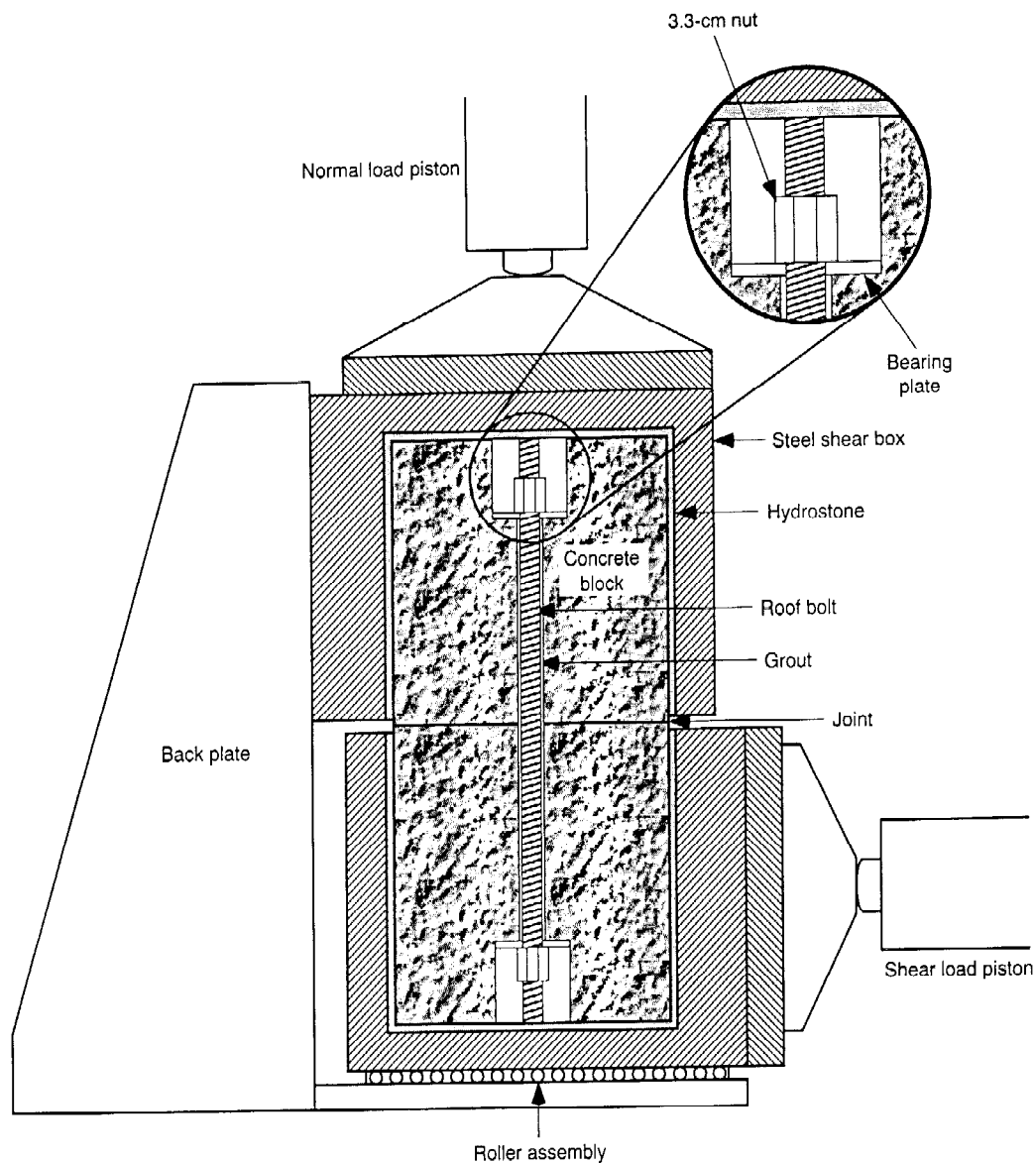

Figure 2.—Shear blocks and test assembly

from all 17 tests on instrumented bolts were considered valid and so are included here.

Calculated loads from all functioning gauges (signals from 3 of the 238 gauges failed prior to tensioning) were used to determine average pretensioned load on the bolt. Special care was required to minimize bending at the ends of the bolts where the plates and nuts secured them to the blocks. The bolts were pretensioned to axial loads ranging from 9.2 to 107.4 kN (2,065 to 24,155 lbf), or as much as 75% (approximately 143.4 kN (32,250 lbf) of the estimated yield strength of the bolts. Tensile tests of No. 7 slotted rebar bolts showed a mean yield point of 163 kN (36,600 lbf) and an ultimate strength of 233 kN (52,300 lbf). Since a vertical load of 8.90 kN (2,000 lbf) had been applied to the block assembly prior

to shearing, effective load on the tensioned bolt was reduced by that amount. Pretensioned bolt loads, applied shear loads, and shear block displacement for each of the 17 bolts are shown in table 1.

Applied Shear Loads and Displacements

The concrete blocks, the joint surface between the blocks, and the pretensioned bolt together comprise a system that responds to shear loading applied during the test. The general relationship between applied shear load and displacement is shown in a profile from test 14 (figure 3). The point at which the curve departs from the initial steep slope to a lesser slope is here designated the yield shear strength of the joint. Mean yield shear strength for these tests

Table 1. Instrumented roof bolt pretensioned loads, shear strengths, and displacement.

Test No.	Pretensioned axial bolt load, kN (lbf)	Joint yield strength		Ultimate joint strength	
		Applied shear load, kN (lbf)	Block displacement, cm (in)	Applied shear load, kN (lbf)	Block displacement, cm (in)
1	9.19 (2,065)	125.90 (28,305)	0.528 (0.208)	242.73 (54,570)	3.091 (1.217)
2	22.17 (4,985)	99.21 (22,305)	0.635 (0.250)	222.78 (50,085)	3.475 (1.368)
3*	24.25 (5,451)	103.02 (23,160)	0.610 (0.240)	216.91 (48,765)	3.226 (1.270)
4	28.68 (6,448)	128.04 (28,785)	0.411 (0.162)	259.14 (58,260)	3.162 (1.245)
5	35.37 (7,951)	93.43 (21,006)	0.767 (0.302)	199.63 (44,880)	3.744 (1.474)
6	39.08 (8,786)	116.36 (26,160)	0.406 (0.160)	220.44 (49,560)	2.827 (1.113)
7	53.28 (11,979)	111.49 (25,065)	0.300 (0.118)	217.51 (48,900)	3.185 (1.254)
8	56.93 (12,799)	120.39 (27,066)	0.721 (0.284)	223.91 (50,340)	3.307 (1.302)
9	62.68 (14,091)	92.95 (20,898)	0.470 (0.185)	213.77 (48,060)	3.261 (1.284)
10	66.35 (14,917)	114.62 (25,770)	0.472 (0.186)	227.98 (51,255)	3.012 (1.186)
11*	70.88 (15,935)	92.61 (20,820)	0.330 (0.130)	235.12 (52,860)	3.294 (1.297)
12	75.37 (16,944)	112.14 (25,212)	0.335 (0.132)	220.44 (49,560)	3.495 (1.376)
13*	83.87 (18,855)	103.26 (23,214)	1.293 (0.509)	240.99 (54,180)	4.277 (1.684)
14	92.41 (20,776)	102.56 (23,058)	0.441 (0.162)	200.16 (45,000)	2.865 (1.128)
15	98.49 (22,142)	111.76 (25,125)	0.330 (0.130)	230.25 (51,765)	3.228 (1.271)
16	100.87 (22,678)	129.10 (29,025)	0.262 (0.103)	233.79 (52,560)	3.175 (1.250)
17	107.44 (24,155)	102.95 (23,145)	0.549 (0.216)	227.58 (51,165)	3.518 (1.385)

* Bolt did not break at maximum shear displacement.

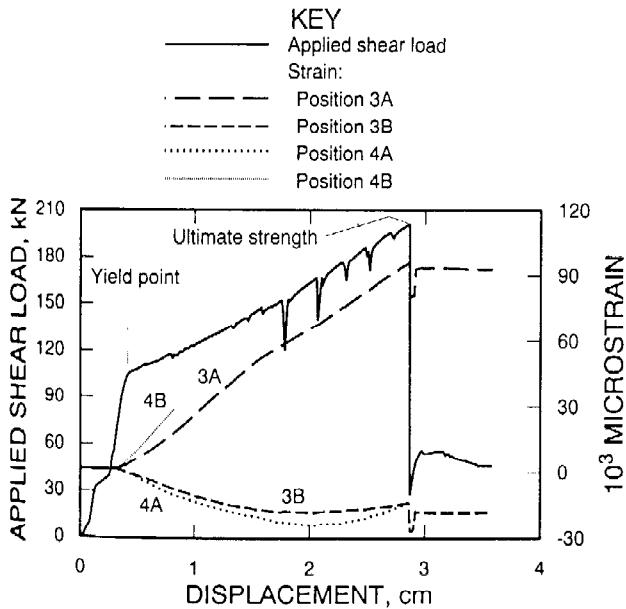

Figure 3.—Load and displacement profile, test 14

was 109.4 kN (24,595 lbf). The point at which the curve beyond the yield shear strength again departs from an approximate straight line because of either bolt failure or rapid loading of the system, is designated as the ultimate shear strength of the joint. Mean ultimate shear strength was 225.5 kN (50,692 lbf). No discernable correlation was found between pretensioned axial loads on the bolt and either yield shear strength or ultimate shear strength of the joint (figure 4). As shear loading progressed, each bolt was deformed into an S bend, with the center part of the bend at an angle to the joint surface between the blocks. In seven cases, applied shear load exceeded the ultimate strength of the bolt. This was attributed to

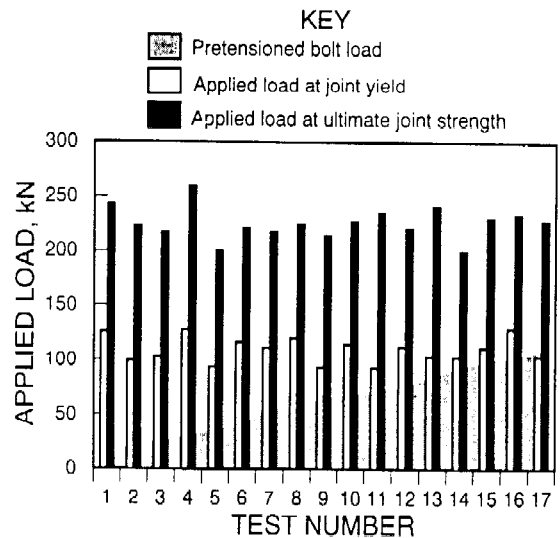

Figure 4.—Pretensioned bolt loads and shear yield/ultimate strength of joint

the bolt being forced through the confined block, crushing the concrete surrounding the hole, which was enclosed on five sides by the steel shear box. Applied shear loads in these cases reached as much as 658 kN (148,000 lbf). In all but three cases (tests 3, 11, and 13), the bolt ultimately broke before the limit of shear displacement was reached.

Displacements at the yield strength of the joint ranged from 0.33 to 1.29 cm (0.13 to 0.509 in) and averaged 0.52 cm (0.204 in). The data are not definitive, but a slight correlation is shown between higher initial axial tension and lower displacement at shear

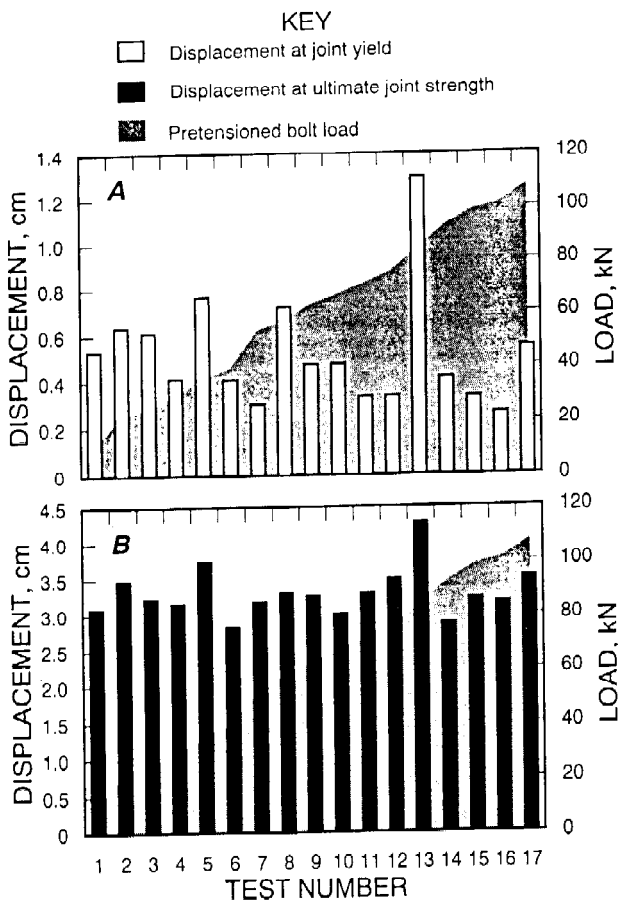

Figure 5.—Relation of initial tension to shear displacement, **A**, Displacement at joint yield strength; **B**, displacement at ultimate joint strength.

yield strength. Displacement at ultimate strength ranged from 2.83 to 4.28 cm (1.113 to 1.684 in) and showed no correlation to initial axial tension; average displacement at ultimate shear strength was 3.30 cm (1.300 in). These relationships are shown in figure 5.

Strain-Gauge Data

Axial and bending strains were calculated for the seven gauge pair positions along the bolt for the duration of each test according to the equations—

$$\epsilon_{\text{axial}} = (\epsilon_{\text{side 1}} + \epsilon_{\text{side 2}})/2 \quad (2)$$

and
$$\epsilon_{\text{bend}} = (\epsilon_{\text{side 1}} - \epsilon_{\text{axial}}) \cdot d/y \quad (3)$$

where d = bolt radius
and y = d - depth of the slot.

Because of the bolt-and-block configuration, the maximum effects of applied shear loads consistently occurred between positions 3 and 4 on the instrumented bolts (figure 1). The gauges at position 4 were at the center of the bolt and therefore in the plane of shearing; electrical connection to these gauges was commonly lost before ultimate strain levels were reached. Signals were

normally not lost for gauges at position 3, and these gauges showed the most consistent maximum strains.

Axial strains at position 3 for all bolts were used to relate pretensioned load to applied shear load. Pretensioned axial strains on the bolts at position 3 ranged from 146 to 1617 microstrain. At shear yield strength of the joints, axial strains ranged from 777 to 2438 microstrain; yield strength of the steel (about 2000 microstrain) was exceeded in only two bolts (tests 7 and 13). Axial strains at ultimate shear strength of the joints ranged from 11,888 to 40,846 microstrain, all well above yield strength of the steel. Variability among tests obscures a generalized correlation between pretensioned bolt loads and axial strain at both yield and ultimate shear strengths of the joints. Mean values were calculated for bolts grouped into those with low (six bolts), moderate (six bolts), and high (five bolts) pretensioned loads (figure 6A).

Bending strains at shear yield strength of the joints were quite uniform and apparently not influenced by initial pretensioned bolt load; yield strength of the steel was exceeded at position 3 for 12 of the bolts. For the grouped data, figure 6B shows a correlation in bending strain between pretensioned bolt loads and ultimate joint shear strength. Bending strains reached as high as 64,029 microstrain at ultimate joint shear strengths.

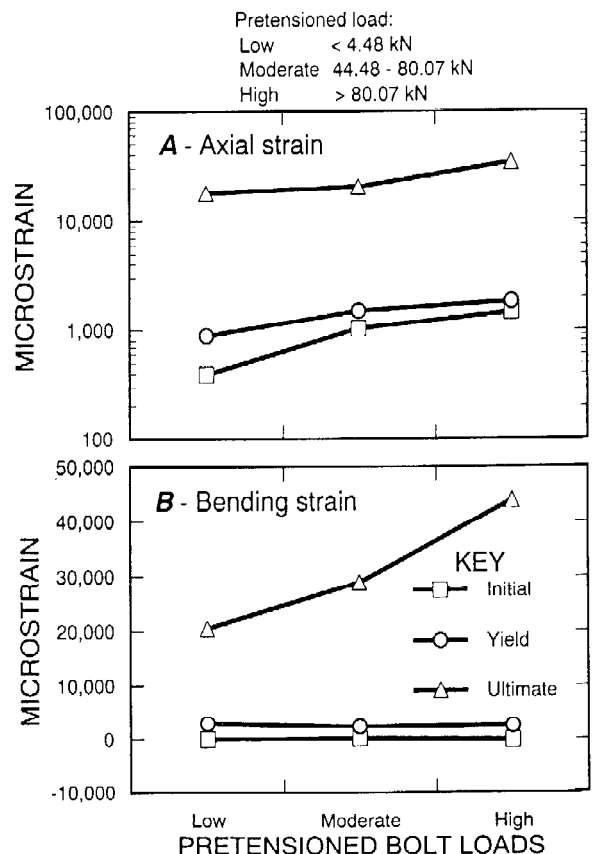

Figure 6.—Axial and bending strains for pretensioned load groups

Strain and load data for gauges at positions 3 and 4 from a representative test (table 1, No. 14) demonstrate how the bolts responded to shear loading (figure 3). Axial strain data for these and other gauges are shown in figure 7. Bolt 14 was pretensioned to 92.41 kN (20,776 lbf) before it was tested. Initial strains on individual gauges ranged from 917 to 1665 microstrain. The effects of applied shear were greatest at gauge sites nearest the center of the bolt. However, signals were lost at positions 4 and 5 before ultimate loads were reached. At the shear yield strength of the joint, axial strain exceeded yield strength of the steel only at position 4. At the ultimate strength of the joint, the yield strength of the steel was exceeded even at position 1, which was 20.3 cm (8 in) from the joint surface.

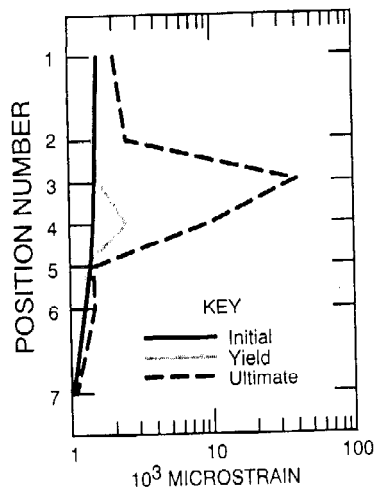

Figure 7.—Axial strain, test 14

Examination of the broken bolt showed that it had been offset 2.3 cm (0.92 in) across the S bend during shearing. About 0.2 cm (0.1 in) of extension was measured in the top 14.1 cm (9.5 in) of the bolt from the bolt end to gauge position 3 (about 10,500 microstrain). The longitudinal centerline of the bolt through the S bend and the rupture extended at least 0.58 cm (0.23 in) over the 10.2 cm (4 in) between positions 3 and 5 (>580,000 microstrain) before the bolt broke. No measurable extension was noted from position 5 to the other end of the bolt.

The gauges at position 3 (figure 8) showed pronounced convex bending on the side of the bolt toward the shear ram (the direction from which shear stress was applied), and strain at gauge 3A increased quickly beyond the yield strength of the steel. On the concave side of the bend (away from the shear ram), strain was compressional, or negative. As shearing proceeded, negative strain decreased to a minimum (-18,000 microstrain for gauge 3B), then reversed and began to increase. Bending at gauge position 4 was reversed from that at position 3, or concave (compressional) on the shear ram side of the bolt. Negative strain decreased to a minimum of -24,000 microstrain at gauge 4A, then began to rise. Strain on the convex side of the bolt (gauge 4B) had already increased to 29,000 microstrain when electrical connection to the gauge was lost. Gauges at position 5 showed bending much reduced, but in the same direction as at position 4.

As was common in all tests, gauges near the ends of the bolt at positions 1 and 7 (20.3 cm [8 in] from the joint surface) responded to shear loading with a slight initial decrease in strain, then an increase at all gauges. No bending was apparent. Gauges at positions 2 and 6, which lay 10.2 cm (4 in) from the center in each direction, also showed eventual increases in axial strain, but also small amounts of bending in the same direction as at positions 3 and 5. Negative strains mirror positive values for gauges on the opposite side of the bolt, but at lesser magnitudes.

CONCLUSIONS

Shear loading of the bolts and the bending that results created tensional (positive) and compressional (negative) strain at the bending site. The effect of applied shear stress was observed throughout the length of the bolt, but was translated to tensional stress at gauges farthest from the joint surface (positions 1 and 7). Bending was observed at gauges 10.2 cm (4 in) from the joint surface (positions 2 and 6), but continuing shear displacement resulted in tensional strain on both sides of the bolt. In two tests, bending strain at positions 2 and 6 exceeded the yield strength of the steel. For all bolts, the magnitude of negative strain was consistently less than the opposing positive strain on the other side of the bolt and was reversed as shearing continued. With increased displacement, strain on both sides of the bolt increased. Eventually applied shear force exceeded ultimate joint strength, and the bolt essentially failed in tension.

The tests suggest that axial loading has little effect on a joint's resistance to shear loading. Yield joint shear strengths may have a minor correlation to axial loading on the bolt, but ultimate joint shear strength is apparently unaffected. Joint shear strength at yield averaged about 76% of expected axial strength of the bolt alone. Field tests in underground coal mines have shown that roof bolts commonly have axial loads beyond their rated yield strength, a condition not duplicated by pretensioned loads in these tests. However, the tests suggest that bolts subjected to these high loads can still provide resistance to shear loading.

Although concrete blocks are similar in compressive strength to the type of host rocks common in coal mines, the hardness of host rocks plays a role in how a bolt responds to shear loading. Concrete on one side of the bolt crushes as it bends, and a void is created on the other side. Very hard host rock would likely tend to slice a bolt off at a joint face rather than allow the bolt to bend. In such cases, bolts may provide less resistance to shear loading. Laboratory tests have been designed to test the effects of shear stresses in harder materials.

Pretensioning of the bolts effectively minimized separation of the joint faces during shear displacement. Unlike fully grouted bolts in mine installations, the nut and plate anchors at the ends of the test bolts ensured that grout failure would not be a factor in load and displacement profiles. Both separation of the shearing faces and plastic failure of grout would tend to propagate bending forces for greater distances along the bolt.

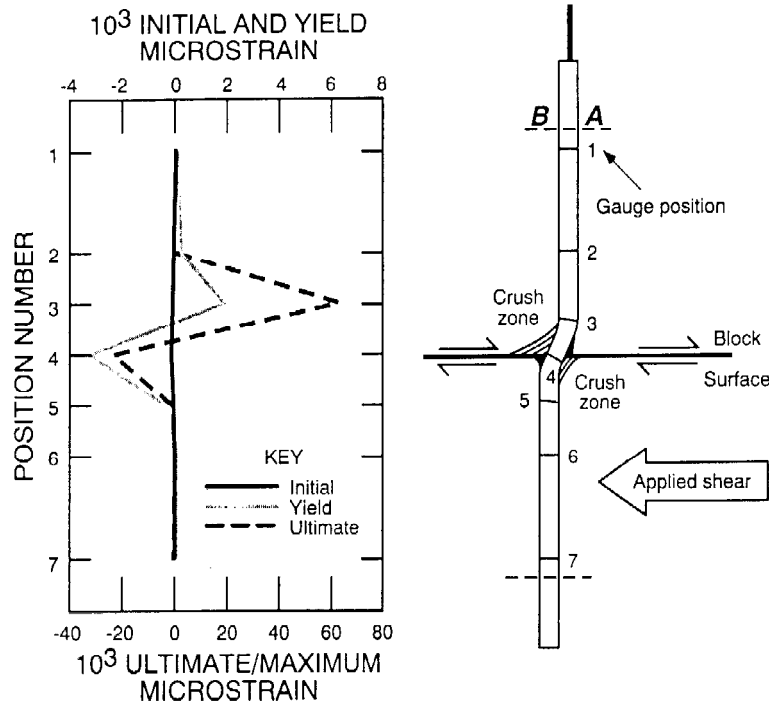

Figure 8.—Bending strain and bolt deformation, test 14.

REFERENCES

- Goris, J. M., L. A. Martin, and R. P. Curtin. Shear Behavior of Cable Bolt Supports in Horizontal, Bedded Deposits. Paper in *Proceedings, 15th International Conference on Ground Control in Mining*, ed. by L. Ozdemir, K. Hanna, K. Y. Haryam, and S. Peng (Golden, CO, Aug. 13-15, 1996). Colorado School of Mines, 1996, pp. 511-521.
- Haas, C. J. Analysis of Rock Bolting to Prevent Shear Movement in Fractured Ground. *Min. Engineering*, June 1981, pp. 698-704.
- Haas, C. J., R. L. Davis, C. J. Keith, J. Dave, W. C. Patrick, and J. R. Strosnider, Jr. An Investigation of the Interaction of Rock and Types of Rock Bolts for Selected Loading Conditions, Third Annual Report. Rock Mechanics and Explosives Research Center, Univ. of Missouri, Rolla, U.S. Bur. Mines Contract Report H0122110, 1976, 283 pp.
- Johnston, J. L., and D. J. Cox. Instrumentation Procedures for Fully Grouted Rock Bolts. U.S. Bur. Mines Inform. Cir. 9341, 1993, 10 pp.
- Pellet, F., P. Egger, and A. M. Ferrero. Contribution of Fully Bonded Bolts to the Shear Strength of Joints: Analytical and Experimental Evaluation. Paper in *Mechanics of Jointed and Faulted Rock. Proceedings of the International Conference on Mechanics of Jointed and Faulted Rock*, ed. by H. P. Rossmannith (Tech. Univ. of Vienna, Vienna, Austria, April 18-20, 1990). Balkema, 1990, pp. 873-878.
- Radcliffe, D. E., and R. E. Stateham. Stress Distribution Around Resin-Grouted Bolts. U.S. Bur. Mines Rep. Invest. 8440, 1980, 39 pp.
- Signer, S. P., D. Cox and J. Johnston. A Method for the Selection of Rock Support Based on Bolt Loading Measurements. In *Proceedings of 16th International Conference on Ground Control in Mining*, ed. by S. S. Peng (Morgantown, WV, Aug. 5-7, 1997). Dept. of Min. Engin., WV Univ., 1997, pp. 183-190.
- Signer, S. P., and J. L. Lewis. A Case Study of Bolt Performance in a Two-Entry Gateroad. Paper in *Proceedings, 17th International Conference on Ground Control in Mining*, ed. by S. S. Peng (Morgantown, WV, Aug. 4-6, 1998). Dept. of Min. Engineer., WV Univ., 1998, pp. 249-256.
- Turner, P. A. Guillotining of Rock Tendons During Rockbursts Due to Shear Displacements on Fracture Planes. Paper in *Proceedings of International Society for Rock Mechanics, Symposium on Design of Rock Reinforcing: Components and Systems* (Johannesburg, S. Africa, Nov. 1987). Int. Soc. for Rock Mech., 1987, pp. 59-65.