



FATALITY ASSESSMENT AND CONTROL EVALUATION

Tower Technician Killed When Guyed Tower Collapsed Case Report 09NY095

CASE SUMMARY

In December 2009, a 46 year-old tower technician fell 43 feet to his death when a guyed communication tower collapsed (Photos 1 and 2). The 380-foot tall tower was supported by 21 guy wires at seven elevations, three at each height (Figures 3 and 4). The lowest three guy wires were at 43 feet. The victim and his coworkers were replacing the guy wires at the time of the incident. The workers first released the lowest three guy wires from the ground anchors. The next set of wires was at 93 feet. The tower immediately bent in response to the removal of the tension in the lowest guy wires. Tension gauge readings indicated that the remaining guy wires were either over-tensioned or tensioned unevenly. The workers adjusted the wires so that the tower was not bent. The victim, who was wearing a safety harness, started climbing the tower to remove the wires at the 43 feet. As he was climbing, the workers on the ground observed the tower to be moving “like a wet noodle.” The victim dropped the three wires and quickly climbed down. He then climbed to 43 feet to install the new guy wires. He successfully attached two wires before switching to the other side of the tower to attach the third wire. Meanwhile, two workers on the ground picked up one of the wires that was just attached and pulled it hand tight. They took enough slack out of the wire so that it was elevated and not touching the ground. At this moment, the tower start to collapse. The tower reportedly buckled or bent at 43 feet where the victim was. The lower section of the tower (from 43 feet down) fell northwest, while the section above 43 feet fell to southeast (180 degrees from the direction where the lower section fell). The whole tower collapsed. The victim, whose harness was still hooked to the tower, suffered fatal crushing and fall injuries. One worker called 911 and the rest ran to attend the victim. The emergency response staff arrived within minutes. The victim was pronounced dead at the scene.

CONTRIBUTING FACTORS

- Temporary guy wires were not installed to support the tower.
- Removal of the guy wires at the 43 feet resulted in an unsupported lower section of 93 feet.
- The new guy wire was pulled hand tight without touching the ground. The weight of the wire added a lateral force to the tower.
- The guy wires were over-tensioned.
- The weight and movement of the climber might have further destabilized the tower.

KEY RECOMMENDATIONS

- *Communication tower owners should have a structural analysis completed and the tower structural integrity confirmed before sending contractors to work on a tower.*
- *Communication tower contractors should use temporary guy wires to maintain tower structural integrity when replacing guy wires.*
- *Communication tower contractors should conduct a job hazard analysis (JHA) and develop standard operating procedure prior to conducting any tower maintenance work.*
- *Communication tower contractors should provide employee training on hazard recognition and prevention.*
- *Owners of communication towers should maintain tower manuals, and tower construction and maintenance records.*



Photo 1. The 380 foot tall guyed tower collapsed killing a 46 year-old tower technician (photo courtesy of OSHA).



Photo 2. The collapsed communication tower (photo courtesy of OSHA).

INTRODUCTION

In December 2009, a 46 year-old tower technician employed by a communication service company fell 43 feet and was fatally crushed when a 380-foot tall guyed tower collapsed. New York State Fatality Assessment and Control Evaluation (NY FACE) staff learned of the incident from internet news media. The Occupational Safety and Health Administration (OSHA) conducted an on-site investigation. The NY FACE investigator reviewed the OSHA and police investigation reports and the death certificate, and discussed the case with the OSHA compliance officer and a representative of a tower worker safety organization while developing this report.

The communication service company had been in business since 1994. It employed seven workers at the time of the incident: five in the field and two in the office. The company had developed OSHA-required safety and health programs, although the implementation of the programs and worker training were not well documented.

The employees were required to purchase their own fall protection gear, gloves, and climbing helmets. If a worker did not have the required equipment, the company would purchase them and then take the money out of the worker's paychecks. The company provided safety glasses and hard hats for the workers.

The victim was hired by the company three months before the incident, although he had worked as a tower technician for at least three years. He completed a Tower Climbing Safety and Rescue course in 2006 and received a certificate. The course was provided by a training company that specialized in developing tower construction and safety training curricula. The tower climber training curriculum was endorsed by major industry trade groups such as National Association of Tower Erectors. The victim also received training in wireless connectors and radio frequency systems and held certificates for both. This was the company's first work-related fatality.

INVESTIGATION

The broadcasting company that owned the tower purchased it in 2003. The tower was used as an AM broadcast tower that simulcasts a FM station. There were no other lessees on the tower at the time of the incident. The broadcasting company did not have a tower manual from the manufacturer. They did not know the make and model of the tower, nor did they know who erected the tower and when it was erected.

The broadcasting company hired contractors to perform tower maintenance and annual inspections. The tower was last inspected in the summer of 2008. During that inspection, the contractor found pitted corrosion on some of the guy wires. The communication service company was contracted to replace the guy wires and then conduct an annual inspection. The company had never replaced guy wires on a guyed tower before.

The tower was a 380 foot tall equilateral triangle column with 17 inches on each side (Figures 1 and 2). The tower column was formed by multiple 10-foot-long sections connected by friction fits with two bolts and nuts per connection. Each section was made of three vertical steel pipes or legs that were braced with round steel bars into the triangular column. The steel pipes were 1.5 inch in (outside) diameter and 0.12 inch thick. Round steel bars that were 7/16 inch in diameter braced the three legs in a continuous zigzag pattern.

The base of the tower was mounted on a metal pin that was embedded into a concrete base in the ground (Photos 3 and 4). The tower was guyed at three corners of the triangle at seven elevations ranging from H1 to H7 respectively at 43, 93, 143, 193, 248, 308 and 368 feet (Figure 3). All guy wires were 1/4 inch diameter cable, with the exception of the three at H7 (368 ft). The H7 guy wires were 5/16 inch diameter.

Two sets of three ground anchors that were 120 degrees from each other were used to secure the guy wires to the ground (Figure 4). The first set of the anchors (A1, A2 and A3) that were closer to the tower (the interior anchors) were 135 feet from the base of the tower. The exterior anchors B1, B2 and B3 were 250 feet from the base of the tower. The guy wires at the three lowest elevations (H1, H2 and H3) were secured to the three interior anchors, while the guy wires at the higher elevations (H4 – H7) were secured to the exterior anchors.

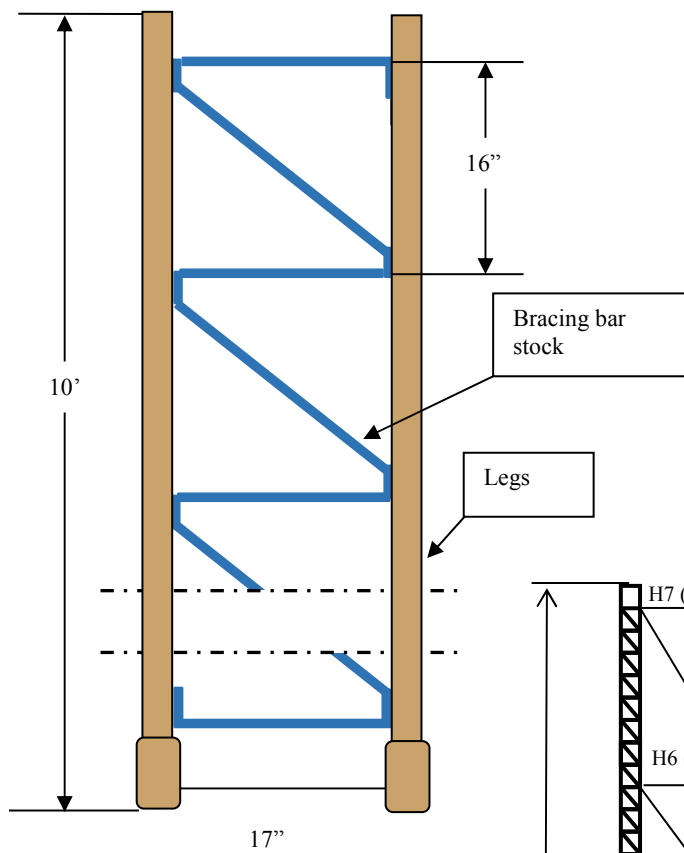

Figure 1*. A section of the tower

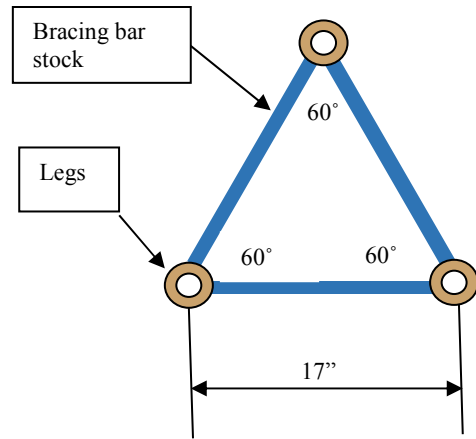

Figure 2*. Top view of the tower

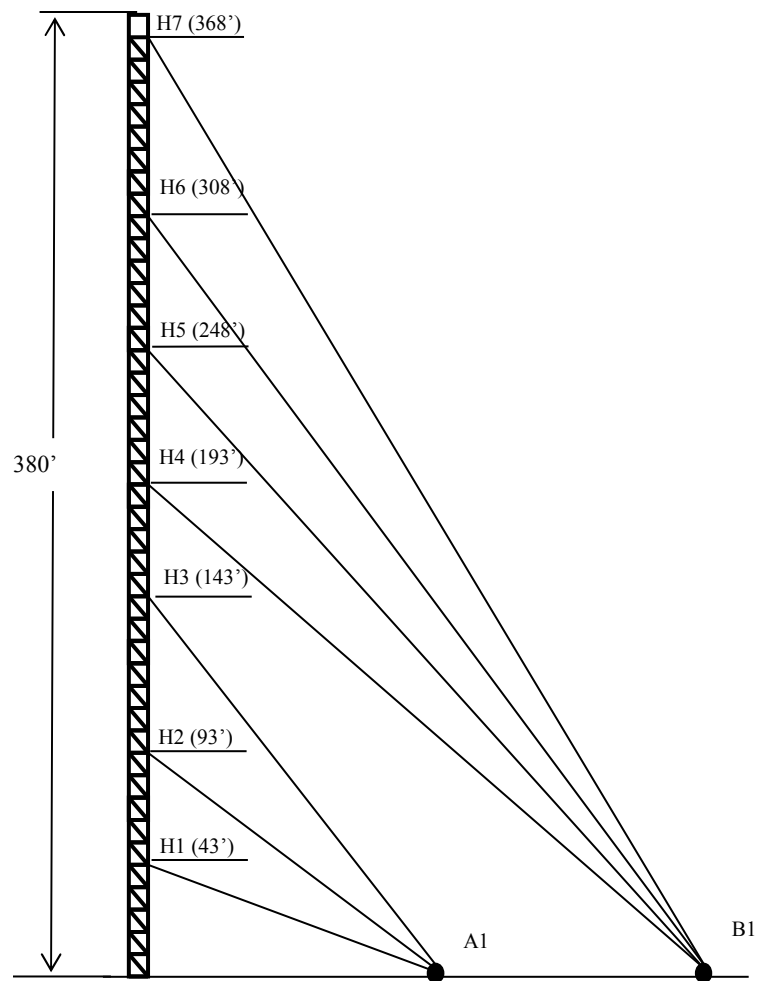

Figure 3*. The guyed tower, the guy wires and the ground guy anchors. Each set of three guy wires were attached to the tower at seven elevations (H1-H7).

*Drawings are not to scale



Photo 3. The base of the communication tower (photo courtesy of OSHA).



Photo 4. The cement base with a metal pin embedded. The base of the tower was mounted on the pin (photo courtesy of OSHA).

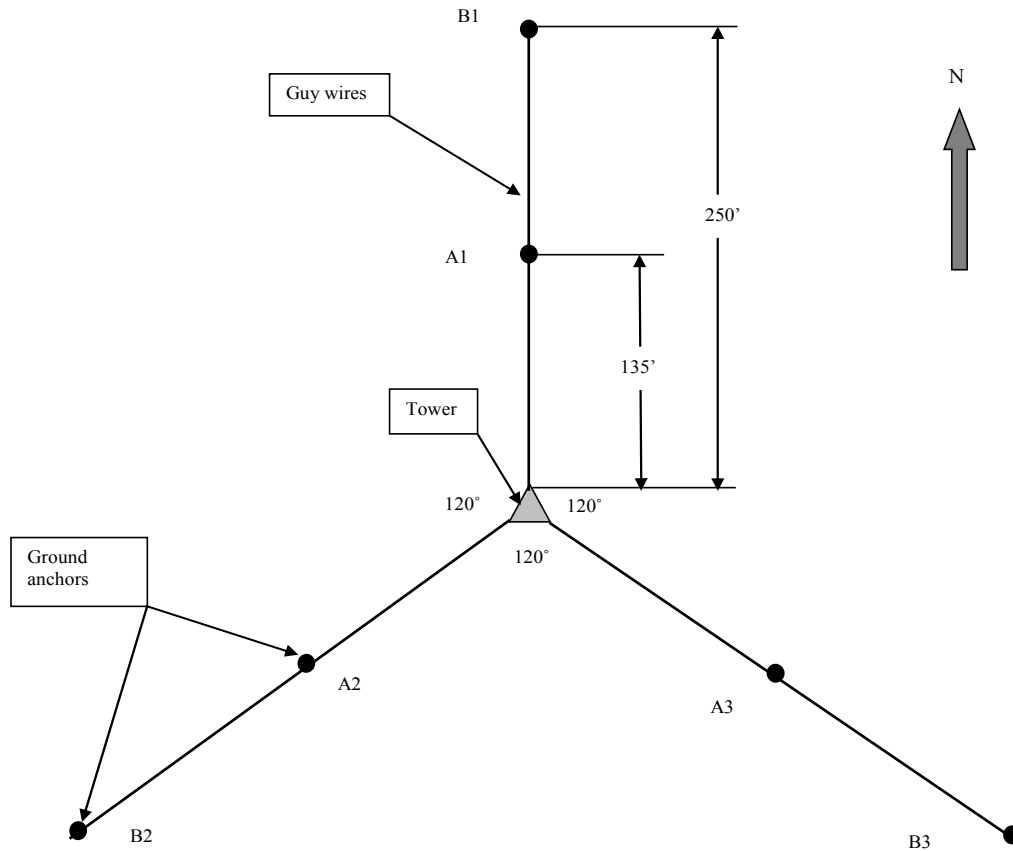

Figure 4. Top view of the tower, the guy wires and the six ground anchors (drawing is not to scale).

Two of the tower parts had “ROHN” casted on them. Based on the configurations and characteristics of the tower, the OSHA compliance officer determined that the tower was manufactured by ROHN (model 55G90R380). The NY FACE investigator compared the tower structure with the manufacturer’s installation specifications and identified multiple deviations. ROHN specified that the tower be guyed by 24 guy wires at eight elevations (45, 92, 135, 181, 227, 273, 319 and 365 feet.), while the tower in this case was guyed by 21 wires at seven elevations (43, 93, 143, 193, 248, 308 and 368 feet). According to ROHN, the interior and exterior anchors for this model should be 110 feet and 304 feet away from the base of the tower respectively; while the interior and exterior anchors for this tower were 135 feet and 250 feet away from the tower base. The sizes of the guy wires were also different from the manufacturer’s specifications.

The incident occurred on the second day of the job. The workers cleared brush and no one climbed the tower on the first day. On the day of the incident, five workers including the victim arrived at the site between 8:30 and 9:20 am. They first turned off the power to the tower. They then positioned one person at each of the three interior anchors (A1, A2 and A3) to which the lowest three groups of guy wires were attached. The workers started releasing the lowest three guy wires attached to the ground anchors evenly. The free standing section of the tower was 93 feet high after the tension was released from the lowest guy wires.

The tower immediately bent in response to the removal of the tensions from the lowest wires. The curve started above the base and extended up, passing the next level of guy wires at 93 feet level. The curve gradually lessened until completely diminished at the third level of guy wires at 143 feet level. The curve was observed by the workers without using the transit that was set up at the site.

The workers used a cable tension meter to measure the tensions on the remaining guy wires. The meter was last calibrated in October 2003 by the manufacturer who recommended annual calibrations. The workers reportedly took readings in more than one location on each wire. The readings equated to tensions between 1,000 and 1250 pounds on wires at H2 and H3, between 1300 and 1800 pounds on wires at H4, H5 and H6 and 1,700 pounds at H7 the highest three wires. The workers adjusted the tensions evenly to 1,100 pounds on the wires at the H2 to H6 levels and to 1,485 pounds on H7 guy wires. ROHN specified the tensions on H1, H2 and H4 as 399 pounds, tensions on H3 and H5 to H7 as 665 pounds and tension on H8 as 1120 pounds. The guy wire tensions exceeded manufacturer's specifications. The workers checked the tower with the transit and it appeared straight.

The victim, who was wearing a fall protection harness, started climbing the tower to remove the guy wires from the tower at the 43 feet level. As he was climbing, the workers on the ground observed the tower to be moving "like a wet noodle." The victim dropped the three wires and quickly climbed down.

The workers measured, cut and made three new wires with 1/4" extra high strength guy wire. There was reportedly a conversation between the victim, the foreman, and the supervisor about using temporary bracing. It was decided that it was too late since the three wires were already down. According to the supervisor, he and the foreman also discussed the use of temporary bracing at the office before they came to the site that day. They decided that they would use the temporary bracing if it was windy and they made sure that they had enough cable for temporary bracing. They had seen plans on other towers that called for temporary bracing if the wind was above 15 miles per hour (mph). They decided that the temporary bracing was not necessary since it was not windy on the ground. According to the internet historical weather data (<http://www.wunderground.com/>), the maximum area wind speed on the day of the incident was 6 mph.

The victim started to climb the tower to install the new guy wires at 43 ft. He was told by the supervisor and the foreman to keep his swinging to a minimum to avoid moving the tower. He successfully attached two wires: one was anchored at the location A1 and the other was anchored at A3. He then switched to the tower face between A2 and A3 so that he could hook up the third wire.

Meanwhile, the two workers at the anchor A1 picked up the guy wire attached to the tower and pulled it hand tight. They took enough slack out of the wire that it was above the ground without touching it. At this moment, the workers saw the tower start to collapse. The tower reportedly buckled or bent at the 43 feet level where the victim was. The lower section of the tower from 43 feet down fell northwest, while the section above 43 feet fell 180 degrees from the direction where the lower section fell. The whole tower collapsed. The victim was still hooked to the tower when the tower hit the ground. His head and body were caught and crushed between the folded sections of the tower. He suffered fatal crushing and fall injuries. One worker called 911 and the rest ran to attend the victim. The emergency response staff arrived within minutes. The victim was pronounced dead at the scene. The immediate cause of death was multiple blunt force injuries.

The OSHA compliance officer who investigated the case examined the collapsed tower. He did not observe any signs of material failure that could have caused the collapse. According to the OSHA compliance officer, the tower collapsed in such a manner that it indicated a “layered collapse.” The free standing lower section fell first followed by the upper sections that were being pulled by the remaining guy wires. It was concluded that following factors may have contributed to the collapse of the tower:

- Removal of the guy wires at 43 feet resulted in an unsupported lower section of 93 feet;
- The new guy wire was pulled hand tight without touching the ground. The weight of the wire added a sideways force to the tower.
- The guy wires were over-tensioned.
- The weight and movement of the climber might have further destabilized the tower.
- The tower was not constructed according to the manufacturer’s specifications.

RECOMMENDATIONS/DISCUSSION

Recommendation #1: *Communication tower owners should have a structural analysis completed and the tower structural integrity confirmed before sending contractors to work on a tower.*

Discussion: Before having any major structural work or maintenance done on a tower, tower owners should have a structural analysis including a corrosion test completed and the tower structural integrity confirmed. The analysis should assess the integrity of the existing tower structure, identify any risk factors associated with the work to be conducted, and assist in developing necessary control and protection measures.

The existing tower in this case deviated from the manufacturer’s construction criteria in many aspects. The number of guy wires, the elevations to which the guy wires were attached, and the locations of the ground anchors as well as the tension on the guy wires were all different from the manufacturer’s original design. A structural analysis may have helped to assess whether these deviations predisposed the tower to structural instability.

Recommendation #2: *Communication tower contractors should use temporary guy wires to maintain tower structural integrity when replacing guy wires on a guyed tower.*

Discussion: Most guyed towers, including the one in this case, are mounted on top of a concrete mound that has a metal pin embedded in it. The pin fits into the tower’s base plate (Photos 3 and 4). The base keeps the tower from sinking under the deadweight of the tower and the pressure of the guy wires. However, the tower base does not keep the tower upright. A guyed tower relies solely on the guy wires to resist lateral forces such as wind loads to stay upright. The guy wires must be properly installed, tensioned, and secured to ground anchors according to the manufacturer’s specifications. If any guy wires are missing or not tensioned properly, the structural integrity of a guyed tower is compromised and the tower may buckle or collapse.

Replacing guy wires involves removing existing guy wires, attaching new guy wires to the tower and ground anchors and tensioning and securing the new wires. A tower climber who wears fall protection gear and carries tools and wires has to climb up or down and move sideways on the tower. Workers on the ground may apply side forces while trying to tension and secure the new wires. All of these factors further weaken the stability support provided by the remaining guy wires and increase the possibility

of tower collapse. It is critical to install temporary guy wires prior to replacing guy wires on a guyed tower to maintain the tower stability and protect workers from getting seriously injured or killed.

Recommendation #3: *Communication tower contractors should conduct a job hazard analysis (JHA) prior to conducting any tower maintenance work and develop a standard operating procedure to ensure worker safety.*

Discussion: Communications tower contractors should conduct a job hazard analysis (JHA) and develop a tower safety work plan prior to starting tower construction or maintenance work. Each tower job presents unique challenges associated with the specific tower structure and configurations, the work activities, the equipment involved, and weather conditions. The JHA should assess the following potential hazards and implement effective prevention measures accordingly:

- Fall from heights
- Electrocuting
- Malfunction of the hoisting and lifting equipment
- Defective or damaged personal fall prevention gear
- Defective ladder safety devices
- Falling objects
- Structural collapse of towers
- Inclement weather conditions

The contractor in this case had never replaced guy wires before. A comprehensive JHA can identify specific risk factors. Standard operating procedures should be developed based on the results of the JHA to control and reduce the risk and ensure worker safety.

Recommendations #4: *Communication tower contractors should provide employee training on hazard recognition and safe working procedures associated with the specific tasks to be performed at each tower site.*

Discussion: Replacing guy wires on a guyed tower is a high risk job. Communication tower contractors should provide employee training that includes how to identify hazards, inspect equipment, and use and maintain personal fall protection gear. Employers should also provide workers with task specific training based on the JHA conducted at each job site. The workers in this case did not receive training on how to safely replace guy wires.

Recommendation #5: *Owners of communication towers should maintain tower manuals and tower construction and maintenance records.*

Discussion: Owners of communication towers should maintain tower manuals, including both parts and maintenance manuals. These manuals contain manufacturer's installation requirements and tower technical specifications. Tower construction and maintenance records should be kept as well. This information can help tower contractors assess the risk factors and identify potential hazards when designing and planning maintenance activities. The owner of the tower in this case did not keep the tower manual and the records on tower construction and maintenance.

Keywords: *guyed tower, tower collapse, replacing guy wires, temporary guy wires, tower technician, fall, crushing injury*

REFERENCES

1. *Structural Standard for Antenna Supporting Structures and Antennas*. ANSI/ TIA-222-G-2005. Telecommunications Industry Association/Electronic Industries Alliance. August 2005.
2. *Preventing Injuries and Deaths from Falls during Construction and Maintenance of Telecommunication Towers*. CDC/NIOSH. Retrieved on April 25, 2014 from <http://www.cdc.gov/niosh/docs/2001-156/pdfs/2001-156.pdf>
3. *Fatal Facts Fall from a Telecommunications Tower*. No. 7-2014. OSHA. Retrieved on April 25, 2014 from <https://www.osha.gov/Publications/OSHA3710.pdf>
4. *55-Year-Old Communications Tower Worker Killed After Falling 60 Feet (08NJ052)*. NJ FACE. Retrieved on April 25, 2014 from <http://www.cdc.gov/niosh/face/stateface/nj/08nj052.html>
5. *Hispanic Tower Erector Falls to Death from Television Tower (03NE019)*. NE FACE. Retrieved on April 25, 2014 from <http://www.cdc.gov/niosh/face/stateface/ne/03ne019.html>
6. *Three Tower Painters Die After Falling 1,200 Feet When Riding the Hoist Line - North Carolina (2000-07)*. NIOSH FACE. Retrieved on April 25, 2014 from <http://www.cdc.gov/niosh/face/in-house/full200007.html>
7. *Tower Construction Worker Dies Following 40-Foot Fall From Cellular Tower in Missouri (99MO138)*. MO FACE. Retrieved on April 25, 2014 from <http://www.cdc.gov/niosh/face/stateface/mo/99mo138.html>
8. *Tower Construction Worker Dies Following 200 Foot Fall From Radio Tower (98MO102)*. MO FACE. Retrieved on April 25, 2014 from <http://www.cdc.gov/niosh/face/stateface/mo/98mo102.html>
9. *Tower Painter Dies and a Second Painter Injured After Falling 900 Feet While inside a Man Basket-South Carolina (9821)*. NIOSH FACE. Retrieved on April 25, 2014 from <http://www.cdc.gov/niosh/face/In-house/full9821.html>
10. *Investigation of the September 24, 2002, Collapse of the 1965-foot High KDUH-TV Antenna Tower in Hemingford, Nebraska*. OSHA. March 2003. Retrieved on April 25, 2014 from https://www.osha.gov/doc/engineering/2003_03_01.html
11. *Investigation of the September 4, 2003, Collapse of the 1000-foot High TV Antenna Tower in Huntsville, Alabama*. OSHA. January 2004. Retrieved on April 25, 2014 from https://www.osha.gov/doc/engineering/2003_09.html

12. *Investigation of the October 23, 1997 Collapse of the 1889' High TV Antenna Tower in Raymond, Mississippi*. OSHA. April 1998. Retrieved on April 25, 2014 from https://www.osha.gov/doc/engineering/1998_r_06.html
13. *Investigation of the October 12, 1996 Collapse of a 1500-foot antenna tower in Cedar Hill, Texas*. OSHA. March 1997. Retrieved on April 25, 2014 from https://www.osha.gov/doc/engineering/1997_r_05.html
14. *Job Hazard Analysis*. OSHA. 2002. Retrieved on November 21 from https://www.osha.gov/Publications/osh3071.pdf?utm_source=rss&utm_medium=rss&utm_campaign=job-hazard-analysis-13

The New York State Fatality Assessment and Control Evaluation (NY FACE) program is funded by the National Institute for Occupational Safety and Health and administered by the New York State Department of Health. NY FACE is a research program designed to study the causes of workplace fatalities and develop practical and effective prevention measures. NY FACE investigators evaluate information from multiple sources and provide recommendations for prevention in summary reports. These recommendations are distributed to employers, workers, and other organizations interested in promoting workplace safety. The NY FACE does not determine fault or legal liability associated with a fatal incident. Names of employers, victims and/or witnesses are not included in written investigative reports or other databases to protect the confidentiality of those who voluntarily participate in the program. Additional information regarding the NY FACE program can be obtained from:

New York State Department of Health FACE Program
Bureau of Occupational Health and Injury Prevention
Corning Tower, Room 1325
Empire State Plaza
Albany, NY 12237
866-807-2130
518-402-7900

BOH@health.state.ny.us

www.nyhealth.gov/nysdoh/face/face.htm