

Clarifications to the VSP 2011 Operations Manual

The following item numbers are being clarified in response to industry questions. Text from the *VSP 2011 Operations Manual* is printed first, then the clarification.

Sections with clarifications:

- 4.0 Acute Gastroenteritis (AGE) Surveillance
- 5.0 Potable Water
- 6.0 Recreational Water Facilities
- 7.0 Food Safety
- 10.0 Child Activity Centers
- 11.0 Ventilation
- 12.0 Administrative Guidelines
- 13.0 Annex

4.0 Acute Gastroenteritis (AGE) Surveillance

4.2.1.1.2 4-hour Update Report (01)

If the number of cases changes after submission of the initial report, an updated report must be submitted no less than 4 hours before the vessel's arrival at the U.S. port. The 4-hour update report must be a cumulative total count of the reported crew and passengers during the entire cruise, including the additional cases.

4.2.1.1.2 Clarification

If there is an update to the AGE surveillance log after the 4-hour report is submitted, an additional 4-hour report must be submitted only if the vessel is still more than 4 hours from arrival in the U.S. port.

If the vessel is less than 4 hours from arrival in the U.S. port, no additional 4-hour report is needed.

4.4.1.2.1 Asymptomatic Cabin Mates or Immediate Contacts of Symptomatic Crew (02)

FOOD and nonFOOD EMPLOYEES:

- Restrict exposure to symptomatic crew member(s).
- Undergo a verbal interview with medical or supervisory staff, who will confirm their condition, provide facts and a written fact sheet about hygiene and handwashing, and instruct them to report immediately to medical if they develop illness symptoms.
- Complete a verbal interview daily with medical or supervisory staff until 48 hours after the ill crew members' symptoms began. The first verbal interview must be conducted within 8 hours from the time the ill crew member initially reported to the medical staff. If the asymptomatic immediate contact or cabin mate is at work, he or she must be contacted by medical or supervisory staff as soon as possible. The date and time of verbal interviews must be

documented.

4.4.1.2.1 Clarification

An immediate contact means sharing a cabin either full or part time or sharing its bathroom facilities. This includes boyfriends, girlfriends, spouses, or other significant others.

If the symptomatic crew member has no cabin mate or other immediate contact, this must be documented.

5.0 Potable Water

5.2.1.2.2 Bunkering/Production Test (08)

After the free residual HALOGEN level of at least 2.0 MG/L (ppm) and PH level not exceeding 7.8 have been reached, the free residual HALOGEN and PH monitoring must be performed at least hourly during the bunkering of POTABLE WATER.

After the free residual HALOGEN level of at least 2.0 MG/L (ppm) and PH level not exceeding 7.8 have been reached, free residual HALOGEN and PH monitoring must be performed at least once every 4 hours during the production of POTABLE WATER.

5.2.1.2.2 Clarification

A test kit must be available for testing free HALOGEN levels and PH.

Test kits must be accurate to within 0.2 MG/L (ppm) for HALOGEN and must have a testing range of free residual HALOGEN normally maintained in the RWF. Test kits for PH must be accurate to within 0.2.

5.2.1.2.4 Analyzer-chart Recorders (06)

HALOGEN and PH analyzer-chart recorders used in lieu of manual tests and logs must be calibrated at the beginning of bunkering or production, and the calibration must be recorded on the chart.

5.2.1.2.4 Clarification

Calibration is required at the beginning of bunkering or production and each time bunkering or production is restarted.

5.3.2.1.1 Identification (08)

POTABLE WATER lines must be striped or painted either in accordance with ISO 14726 (blue/green/blue) or blue only.

DISTILLATE and PERMEATE lines directed to the POTABLE WATER system must be striped or painted in accordance with ISO 14726 (blue/gray/blue).

Other lines must not have the above color designations.

These lines must be striped or painted at 5 meter (15 feet) intervals and on each side of partitions, decks, and bulkheads except where decor would be marred by such markings. This includes POTABLE WATER supply lines in technical lockers.

POTABLE WATER lines after reduced pressure assemblies must not be striped or painted as POTABLE WATER.

Striping is not required in FOOD AREAS of the vessel because only POTABLE WATER is permitted in these areas.

All refrigerant brine lines in all galleys, pantries, and cold rooms must be uniquely identified to prevent CROSS-CONNECTIONS.

5.3.2.1.1 Clarification

The unique identification of refrigerant lines also includes nonpotable chilled water lines, such as on ice machines, ice cream machines, etc.

5.3.2.1.6 Technical Water (08)

If used on the vessel, TECHNICAL WATER must be bunkered through separate piping using fittings incompatible for POTABLE WATER bunkering.

5.3.2.1.6 Clarification

This does not apply to water bunkered from the shore-side municipal water supply.

5.5.2.2.1 Charts (06)

HALOGEN analyzer-chart recorder charts must be changed, initialed, and dated daily. Charts must contain notations of any unusual events in the POTABLE WATER system.

5.5.2.2.1 Clarification

If electronic data loggers are used in lieu of chart recorders, notations of any unusual events in the POTABLE WATER system must be recorded in a log.

6.0 Recreational Water Facilities

6.2.1.1 Fill Level and Turnover Rates (10)

For RWF with skim gutters, the fill level of the RWF must be to the skim gutter level.

TURNOVER rates: Recirculation systems and EQUIPMENT, including chemical control EQUIPMENT, UV DISINFECTION systems, filters, and pumps, must be designed to maintain ADEQUATE water chemistry control while operating at the

following TURNOVER rates:

RECREATIONAL WATER FACILITY	TURNOVER Rate
SWIMMING POOL (<i>VSP 2005 Construction Guidelines</i> or earlier)	6 hours
SWIMMING POOL (<i>VSP 2011 Construction Guidelines</i> or later)	4 hours
CHILDREN'S POOL	0.5 hours
WADING POOL	1 hours
WHIRLPOOL SPA	0.5 hours
SPA POOL	2 hours
INTERACTIVE RWF or ACTIVITY POOL (< 610 millimeters [24 inches] deep)	1 hours
INTERACTIVE RWF or ACTIVITY POOL (> 610 millimeters [24 inches] deep)	2 hours
BABY-ONLY WATER FACILITY	0.5 hours

SPA POOLS that were constructed before June 1, 2005, and which were originally considered SWIMMING POOLS may have a TURNOVER rate not to exceed 6 hours in a 24-hour period. This does not apply to SWIMMING POOLS that have been converted to SPA POOLS.

An RWF slide that is combined with a pool must have a TURNOVER rate that matches the rate for the pool.

6.2.1.1 Clarification

Use flow rates from flow meters to calculate TURNOVER rates. Do not use the manufacturer's pump rate to calculate TURNOVER rates.

For the statement "An RWF slide that is combined with a pool must have a TURNOVER rate that matches the rate for the pool," pool refers to either WADING or SWIMMING POOLS but not CHILDREN'S POOLS. In addition, the water for the slide must come directly from the basin of the pool and return directly to the basin of the pool.

For facilities that meet the definition of more than one type of RWF, the more protective TURNOVER rate applies. For example, if a CHILDREN'S POOL also has features of an interactive RWF or ACTIVITY POOL, the TURNOVER rate must be 0.5 hours. The only exception is that when a slide is combined with a pool, the TURNOVER rate for the combined system may match the rate for the pool. However, if a pool and slide combination is also combined with another facility, the most protective TURNOVER rate applies. Finally, if a facility is modified, the most protective TURNOVER rate applies.

(See also clarification for 6.2.2.1.1 for HALOGEN residual.)

6.2.1.2.6 Filter Housing Cleaning and Disinfection (10)

The filter housing must be cleaned, rinsed, and disinfected before the new filter media is placed in it. DISINFECTION must be accomplished with an appropriate HALOGEN-based DISINFECTANT. At a minimum, a 50-ppm solution for 1 minute, or equivalent CT VALUE, must be used. Records must be maintained on all inspection and cleaning procedures.

6.2.1.2.6 Clarification

The filter housing must be cleaned, rinsed, and disinfected each time the filter media—including cartridge filter—is changed.

6.2.1.2.7 Hair and Lint Strainer (10)

The hair and lint strainer and hair and lint strainer housing on all RWFs must be cleaned, rinsed, and disinfected weekly. DISINFECTION must be accomplished with an appropriate HALOGEN-based DISINFECTANT. At a minimum, a 50-ppm solution for 1 minute, or equivalent CT VALUE, must be used. Records must be maintained on all inspection and cleaning procedures.

6.2.1.2.7 Clarification

If there is not a hair and lint strainer but there is a filter before the pump, this filter must be cleaned, rinsed, and sanitized.

6.2.1.5 Bather Loads (10)

Documentation must be maintained on the maximum bather load for each RWF. The maximum bather load must be based on the following factor: One person per five gallons (19 liters) per minute of recirculation flow.

6.2.1.5 Clarification

Use flow rates from flow meters to calculate bather loads. Do not use the manufacturer's pump rate to calculate bather loads.

6.2.1.6.1 Water Chemistry (10)

The RWF's flow rates, free and combined HALOGEN levels, PH, total alkalinity, and clarity must be monitored and adjusted as recommended by the manufacturer and to maintain optimum public health protection and water chemistry.

Evaluate bather load and make adjustments to water parameters to maintain optimum water quality.

6.2.1.6.1 Clarification

Install flow meters to monitor flow rates. Only combined chlorine must be monitored.

Combined bromine does not need to be monitored.

“Manufacturer” refers to the RWF manufacturer and also to manufacturers of the pumps, filters, flow meters, and any other associated equipment.

6.2.1.6.2 Fecal and Vomit Accident (10)

A fecal and vomit accident response procedure that meets or exceeds the procedure provided in Annex 13.8 must be available for review during inspections.

6.2.1.6.2 Clarification

CDC recommends a pH range of 7.2 to 7.5 for loose stool accidents for inactivating *Cryptosporidium*. This clarification also applies to Annex 13.8.

6.2.2.1.1 Residual (09)

A free residual HALOGEN in the ranges detailed in the table below must be maintained in recirculated RWFs.

Recreational Water Facility	Free HALOGEN Residual, MG/L (ppm)
SWIMMING POOL	≥ 1.0 and ≤ 5.0
CHILDREN'S POOL	≥ 1.0 and ≤ 5.0
WADING POOL	≥ 1.0 and ≤ 5.0
Interactive RWF (ACTIVITY POOL)	≥ 2.0 and ≤ 5.0
BABY-ONLY WATER FACILITY	≥ 3.0 and ≤ 10.0 free chlorine ≥ 4.0 and ≤ 10.0 bromine
WHIRLPOOL SPA and SPA POOL	≥ 3.0 and ≤ 10.0 free chlorine ≥ 4.0 and ≤ 10.0 bromine

6.2.2.1.1 Clarification

For facilities that meet the definition of more than one type of RWF, the more protective HALOGEN residual applies. For example, if a children's pool also has features of an interactive RWF or ACTIVITY POOL, the HALOGEN range must be 2.0 to 5.0 ppm. Finally, if a facility is modified, the most protective HALOGEN residual applies.

(See also clarification for 6.2.1.1 for TURNOVER rates.)

6.2.2.2.3 Automated Free Halogen Residual and pH Testing (10)

Install chart recorders or electronic data loggers with security features that record PH and HALOGEN measurements for each individual RWF. The sample line for the analyzer probe (monitoring) must be either directly from the RWF or on the return line from each RWF and before the compensation tank. Install appropriate sample taps for analyzer calibration.

In the event of EQUIPMENT failure, free residual HALOGEN and PH must be measured by a manual test kit at the RWF or return line at least hourly for WHIRLPOOL SPAS, SPA POOLS, CHILDREN'S POOLS, and WADING POOLS and every 4 hours for all other RWFs.

Manual readings must be recorded on a chart or log, retained for at least 12 months, and available for review during inspections.

Repairs on malfunctioning HALOGEN analyzer-chart recorders must be completed within 30 days of EQUIPMENT failure.

Provide an audible alarm in a continuously occupied watch station (e.g., the engine control room) to indicate low and high free HALOGEN and PH readings in each RWF.

6.2.2.2.3 Clarification

If two RWFs are combined and the water for one RWF comes from and returns to the basin of the other RWF (not the compensation tank), separate monitoring systems are not required. Monitoring is then only required on the main RWF (e.g., a slide and SWIMMING POOL). Note: During operational inspections, VSP will take manual samples of both RWFs.

6.2.2.2.6 Data Logger (10)

If an electronic data logger is used in lieu of a chart recorder, it must have certified data security features.

Manual comparison tests for free HALOGEN residual and PH must be conducted before opening the RWF to verify calibration. The analyzer reading must be within 0.2 ppm for free HALOGEN and 0.2 for PH.

For RWFs open longer than 24 hours, a manual comparison test must be conducted every 24 hours.

6.2.2.2.6 Clarification

Electronic data logging must be in increments of ≤ 15 minutes.

6.3.2.1.2 Shock Halogenation (10)

The free residual HALOGEN must be increased to at least 10.0 MG/L (ppm) and circulated for at least 1 hour every 24 hours.

The free residual HALOGEN must be tested at both the start and completion of shock halogenation.

The water in the entire RWF system must be superhalogenated to 10 ppm to include the WHIRLPOOL SPA/SPA POOL tub, compensation tank, filter housing, and all associated piping before starting the 1-hour timing.

Batch halogenation of the tub and compensation tank may help in reaching the minimum 10 ppm residual quickly.

Facilities filled only with SEAWATER are exempt from this requirement.

6.3.2.1.2 Clarification

Heated ACTIVITY POOLS, including INTERACTIVE RWFs, that have features that break the water surface of the RWF or create a mist must be shock halogenated as described. This includes ACTIVITY POOLS and INTERACTIVE RWFs that can be heated by the sun and/or exterior temperature.

6.7.1.2.1 Life Saving (10)

A rescue or shepherd's hook and an APPROVED flotation device must be provided at a prominent location (visible from the full perimeter of the pool) at each RWF that has a depth of 1 meter (3 feet) or greater. These devices must be mounted in a manner that allows for easy access during an emergency.

- The pole of the rescue or shepherd's hook must be long enough to reach the center of the deepest portion of the pool from the side plus 2 feet (0.6 meters). It must be a light, strong, nontelelescoping material with rounded, nonsharp ends.
- The APPROVED flotation device must include an attached rope that is at least 2/3 of the maximum pool width.

6.7.1.2.1 Clarification

The rescue or shepherd's hook must be long enough to touch the bottom center of the deepest portion of the RWF plus 2 feet (0.6 meters) as measured from the closest edge without an obstruction. This edge can only be used for measurement if someone could freely walk down both sides without an obstruction such as a waterfall, fountain, statue, etc.

For a rectangular pool, the shorter distance would be from the long side of the rectangle as long as there are no obstructions (Figure 1). The 2 feet (0.6 meters) is measured from where the shepherd's hook crosses the fill line of the RWF.

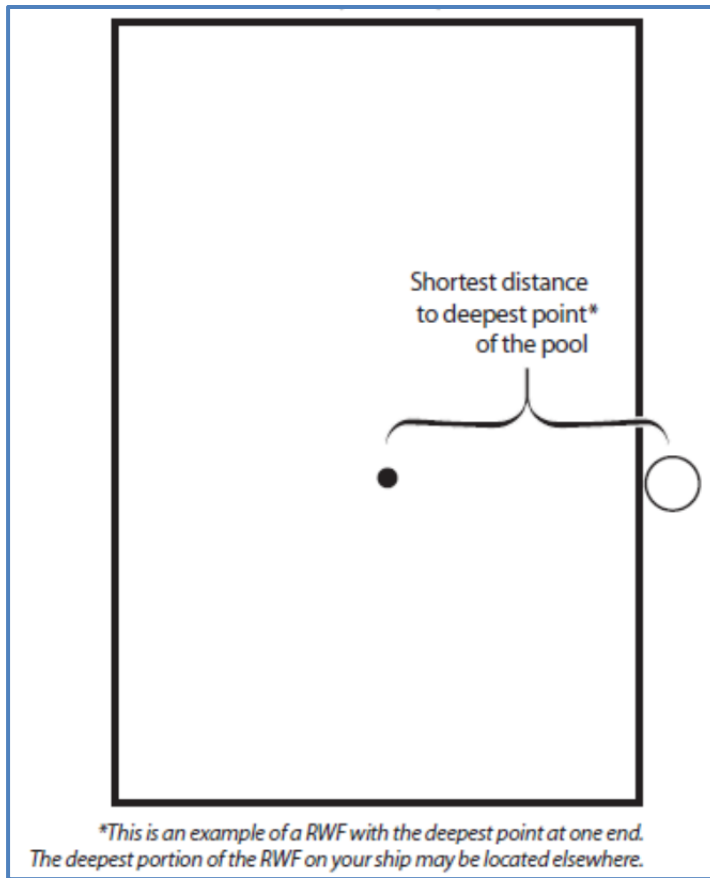

Figure 1. Shortest Distance in a Rectangular Pool

For RWFs with a beach level, the measurement can be from the edge of the tub (Figure 2).

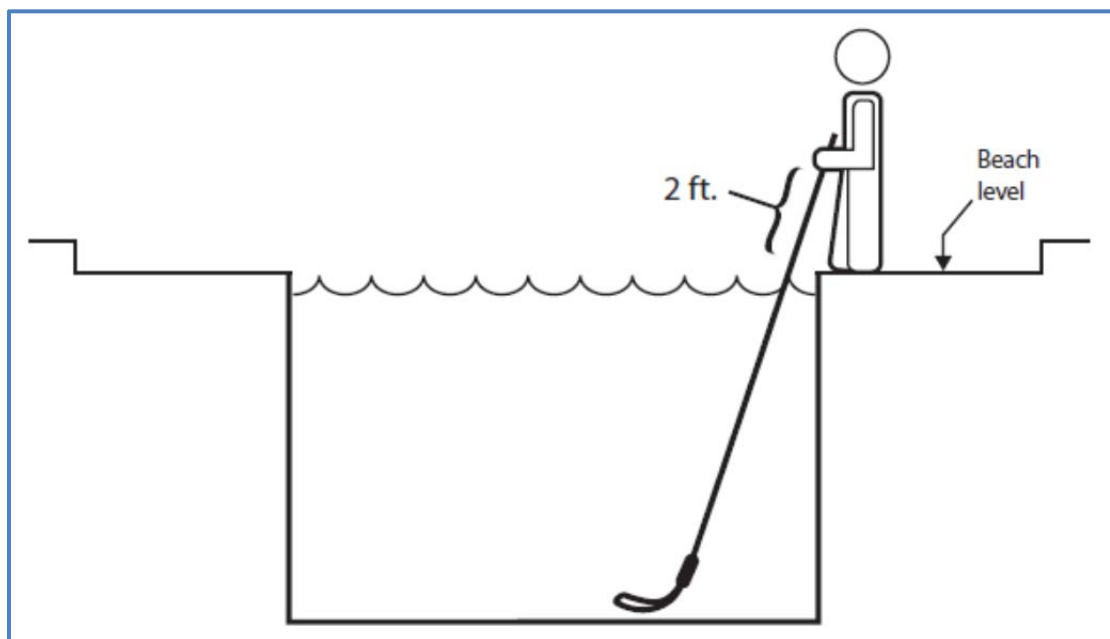

Figure 2. Measurement in RWFs with a Beach Level

6.7.1.1.3 **Spas (10)**

In addition to the safety sign requirements in section 6.7.1.1.1, install a sign at each WHIRLPOOL SPA and SPA POOL entrance listing precautions and risks associated with the use of these facilities.

Include, at a minimum, cautions against use by the following:

- Individuals who are immunocompromised.
- Individuals on medication or who have underlying medical conditions such as cardiovascular disease, diabetes, or high or low blood pressure.
- Pregnant women, elderly persons, and children.

Additionally, caution against exceeding 15 minutes of exposure.

Vessels can submit existing signs for review by VSP.

It is advisable to post additional cautions and concerns on signs.

6.7.1.1.3 **Clarification**

Those under 16 years of age are considered children for the purpose of whirlpool safety sign requirements.

6.7.1.2.2 **Antientrapment Drain (10)**

ANTIENRAPMENT/ANTIENANGLEMENT requirements for drain covers and SUCTION FITTINGS in RWFs are shown in Table 6.7.1.2.2 (below).

This does not apply to facilities with zero depth where the drains are not under direct suction.

VSP is aware that the requirements shown in Table 6.7.1.2.2 for existing vessels may not fully meet the letter of the Virginia Graeme Baker Act, but we also recognize the life-safety concerns for rapid dumping of RWFs in conditions of instability at sea. Therefore, it is the owner's decision to meet or exceed the VSP requirements.

Testing of manufactured drain covers must be by a nationally or internationally recognized testing laboratory.

The information below must be stamped on each manufactured ANTIENRAPMENT drain cover:

- Certification standard and year.
- Type of drain use (single or multiple).
- Maximum flow rate (in gallons or liters per minute).
- Type of fitting (suction outlet).
- Life expectancy of cover.
- Mounting orientation (wall, floor, or both).
- Manufacturer's name or trademark.
- Model designation.

The design of custom/shipyard constructed (field fabricated) drain covers

and SUCTION FITTINGS must be fully specified by a REGISTERED DESIGN PROFESSIONAL in accordance with ASME A112.19.8-2007. The specifications must fully address cover/grate loadings, durability, hair, finger and limb entrapment issues, cover/grate secondary layer of protection, related sump design, and features specific to the RWF.

A letter from the shipyard must accompany each custom/shipyard constructed (field fabricated) drain cover fitting. At a minimum the letter must specify the shipyard, name of the vessel, specifications and dimensions of the drain cover, as detailed above, as well as the exact location of the RWF for which it was designed. The name of and contact information for the REGISTERED DESIGN PROFESSIONAL and signature must be on the letter.

Table 6.7.1.2.2 ANTIENTRAPMENT Requirements for Recreational Water Facilities

Option*	Drainage/Recirculation System	Cover Design	Secondary ANTIENTRAPMENT Requirement**
	GRAVITY ONLY		
1	Multiple drains (2 or more drains greater than 3 feet apart)	Standard design (not compliant with ASME A112.19.8)	Alarm
2	Multiple drains (2 or more drains greater than 3 feet apart)	ASME A112.19.8 compliant cover	None
3	Single unblockable drain (per ASME A112.19.8)	Standard design (not compliant with ASME A112.19.8)	Alarm
4	Single unblockable drain (per ASME A112.19.8)	ASME A112.19.8 compliant cover	None
5	Single BLOCKABLE drain or multiple drains (less than 3 feet apart)	ASME A112.19.8 compliant cover	GDS
	SUCTION FITTING		
6	Multiple drains (2 or more drains per pump with drains greater than 3 feet apart)	ASME A112.19.8 compliant cover	None
7	Single unblockable drain (per ASME A112.19.8-2007)	ASME A112.19.8 compliant cover	SVRS or APS
8	Single BLOCKABLE drain or multiple drains (less than 3 feet apart)	ASME A112.19.8 compliant cover	SVRS or APS

*Options 1 through 5 are for fittings that are not under direct suction. These include both fittings to drain the RWF and fittings used to recirculate the water. Options 6 through 8 are for fittings that are under direct suctions. These include fittings to drain the RWF and fittings used to recirculate the water.

**Definitions:

- Alarm = the audible alarm must sound in a continuously manned space AND at the RWF. This alarm is for all draining: accidental, routine, and emergency.
- GDS (GRAVITY DRAINAGE system) = a drainage system that uses a collector tank from which the pump draws water. Water moves from the RWF to the collector tank due to atmospheric pressure, gravity, and the displacement of water by bathers. There is no direct suction at the RWF.
- SVRS (safety vacuum release system) = a system which stops the operation of the pump, reverses the circulation flow, or otherwise provides a vacuum release at a suction outlet when a blockage is detected. System must be tested by an independent third party and found to conform with ASME/ANSI A112.19.17 or ASTM standard F2387.
- APS (automatic pump shut-off system) = a device that detects a blockage and shuts off the pump system. A manual shut-off near the RWF does not qualify as an APS.

6.7.1.2.2 Clarification

ASME A112.19.8-2007 has been replaced by ANSI/APSP-16 2011. ANTIENTRAPMENT protection equipment (covers, suction fittings, safety vacuum release system—SVRS**, etc.) must comply with ASME A112.19.8-2007—or any successor standards—whether the equipment is manufactured or field fabricated.

7.0 Food Safety

7.2.4.2.1 Hair Restraints (14)

FOOD EMPLOYEES must wear hair restraints—such as hats, hair coverings or nets, beard restraints—and clothing that covers body hair. These items must be designed and worn to effectively keep their hair from contacting exposed food; clean EQUIPMENT, UTENSILS, and LINENS; and unwrapped SINGLE-SERVICE and SINGLE-USE ARTICLES.

This section does not apply to FOOD EMPLOYEES such as counter staff who serve only BEVERAGES and wrapped or PACKAGED foods, hostesses, and wait staff if they present a minimal risk for contaminating exposed food; clean EQUIPMENT, UTENSILS, and LINENS; and unwrapped SINGLE-SERVICE and SINGLE-USE ARTICLES.

7.2.4.2.1 Clarification

This applies to partial beards (such as goatees) and to heavy, pronounced mustaches.

7.3.3.5 Food Storage and Protection

7.3.3.5 Clarification

This applies to storage of candy and other food items sold in candy shops, including self-service candy shops and shops where the candy is served by a crew member.

7.3.3.6 Food Display and Service

7.3.3.6 Clarification

This applies to self-service candy shops where customers serve themselves from candy displays or dispensers.

7.3.5.3.6 Time Control Plan (16 C)

A written time control plan(s) that ensures compliance with these guidelines must be maintained on the vessel and made available for review during inspections (Annex 13.11). A time control plan must be posted at each outlet where time control is used. The plan(s) must

- Include set-up and discard times for each outlet.
- List refrigeration and hot holding units (compartments and cabinets) on time control (the physical units must also be labeled as such).

- Describe or show the flow of POTENTIALLY HAZARDOUS FOOD from when last in temperature control to placement in time control and discard.

7.3.5.3.6 Clarification

Time control plans must identify all refrigeration and hot holding units on time control, but only cabinets and compartments on time control must be labeled.

EQUIPMENT that does not have cabinets or compartments does not need to be labeled as time control. Such EQUIPMENT includes bains marie, cold tops, and soup wells.

Containers of POTENTIALLY HAZARDOUS FOOD under time control and placed on preparation counters must be labeled with the discard time, even if the outlet is open less than 4 hours.

7.7.1 Handwashing and Toilet Facilities

This applies to toilet facilities for galley personnel even if ACCESSIBLE to other crew members.

7.7.1 Clarification

Sections 9.1.1.1.7 and 9.1.1.1.8 [below] also apply to this section.

9.1.1.1.7 Hands-free Exit (41)

Passenger and crew public toilet facilities must be equipped so that persons exiting the toilet room are not required to touch the door handle with bare hands.

Where toilet stalls include handwashing facilities, the bare-hands-free contact must begin in the toilet stall. Toilet facilities with multiple exits, such as spa dressing rooms, must have bare-hands-free contact at each exit.

This may be accomplished by methods such as locating paper towel dispensers at sinks and waste containers near the room door, installing mechanically operated doors, removing doors, or using other effective means.

9.1.1.1.8 Sign (41)

A sign must be posted advising users of toilet facilities to use hand towel, paper towel, or tissue to open the door unless the exit is hands free.

A pictogram that illustrates the correct use and disposal of paper towels as written in section 9.1.1.1.7 may be used in lieu of a sign.

7.7.1.1.1 Convenient (29C)

Each FOOD PREPARATION AREA, bar, WAREWASHING area, and garbage-processing area must have at least one handwashing facility in it.

7.7.1.1.1 Clarification

This applies to self-service and served candy shops where employees serve candy, refill self-service containers, etc.

7.7.4 Decks, Bulkheads, and Deckheads

7.7.4 Clarification

This applies to self-service and served candy shops where employees serve candy and refill self-service containers and consumers serve themselves.

7.7.5 Lighting

7.7.4 Clarification

This applies to self-service and served candy shops where employees serve candy and refill self-service containers and consumers serve themselves.

10.0 Child Activity Centers

10.2.2 Facilities

10.2.2 Clarification

Sections 9.1.1.1.6, 9.1.1.1.7, and 9.1.1.1.8 also apply to this section, except that the sign advising users to wash hands (in section 9.1.1.1.6) is not required.

9.1.1.1.6 Public Toilet Facilities (41)

Passenger and crew public toilets (not including food-area toilets) must be provided with a handwashing station that includes the following:

- Hot and cold running water.
- Soap.
- A method to dry hands (e.g., sanitary hand-drying device, paper towels).
- A sign advising users to wash hands (pictograms are acceptable).

9.1.1.1.7 Hands-free Exit (41)

Passenger and crew public toilet facilities must be equipped so that persons exiting the toilet room are not required to touch the door handle with bare hands.

Where toilet stalls include handwashing facilities, the bare-hands-free contact must begin in the toilet stall. Toilet facilities with multiple exits, such as spa dressing rooms, must have bare-hands-free contact at each exit.

This may be accomplished by methods such as locating paper towel dispensers at sinks and waste containers near the room door, installing mechanically operated doors, removing doors, or using other effective means.

9.1.1.1.8 Sign (41)

A sign must be posted advising users of toilet facilities to use hand towel, paper towel, or tissue to open the door unless the exit is hands free.

A pictogram that illustrates the correct use and disposal of paper towels as written in section 9.1.1.1.7 may be used in lieu of a sign.

10.2.2.1.1 Child-size Toilet (42)

If toilet rooms are located in a CHILD ACTIVITY CENTER, child-size toilet(s) or child-accessible toilet(s) (child-size seat and step stool) and handwashing facilities must be provided.

Child-size toilets (to include the toilet seat) must have a maximum height of 280 millimeters (11 inches) and a toilet seat opening no greater than 203 millimeters (8 inches).

Handwashing sinks must have a maximum height of 560 millimeters (22 inches) above the deck or a step stool must be provided.

10.2.2.1.1 Clarification

Sink height does not apply to handwashing stations outside of the toilet room. However, VSP recommends a maximum height of 560 millimeters (22 inches) above the deck for all children's handwashing stations. If the sink is higher than 560 millimeters (22 inches), VSP recommends providing a step stool.

11.0 Ventilation

11.2.2.1.2 Showers (43)

Shower heads must be cleaned and disinfected every 6 months. DISINFECTION must be accomplished with an appropriate HALOGEN-based DISINFECTANT at 10 ppm for 60 minutes, or an equivalent CT VALUE.

11.2.2.1.2 Clarification

Shower head cleaning and DISINFECTION must be recorded in a log and maintained on the vessel.

12.0 Administrative Guidelines

12.6.1.1 Corrective Actions

Signed corrective-action statements (Annex 13.16) must be submitted to the VSP Chief by the master, owner, or operator. Corrective-action statements must detail each deficiency identified during the inspection and the corrective action taken.

12.6.1.1 Clarification

Corrective-action statements (Annex 13.16) must be submitted to the VSP Chief by the master, owner, or operator within 2 weeks of receiving the final inspection report.

13.0 Annex

13.7 Baby-only Water Facility

13.7.8.2 Safety Sign

A safety sign must be posted by the facility with letters at least 26 millimeters (1 inch) high at each entrance to the BABY-ONLY WATER FACILITY feature that states, at a minimum, the following:

- This facility is only for use by children in diapers or who are not completely toilet trained.
- Children who have a medical condition that may put them at increased risk for illness should not use these facilities.
- Children who are experiencing symptoms such as vomiting, fever, or diarrhea are prohibited from using these facilities.
- Children must be accompanied by an adult at all times.
- Children must wear a clean swim diaper before using these facilities. Frequent swim diaper changes are recommended.
- Do not change diapers in the area of the BABY-ONLY WATER FACILITY. A diaper changing station has been provided (exact location) for your convenience.

13.7.8.2 Clarification

The letters on the sign heading must be at least 26 millimeters (1 inch) high, but all other lettering must be at least 13 millimeters (1/2 inch) high.

13.8 Fecal, Vomit, and Blood Accident Response for RWFs

The clarification in 6.2.1.6.2 also applies to 13.8:

6.2.1.6.2 ***Fecal and Vomit Accident (10)***

A fecal and vomit accident response procedure that meets or exceeds the procedure provided in Annex 13.8 must be available for review during inspections.

6.2.1.6.2 ***Clarification***

CDC recommends a pH range of 7.2 to 7.5 for loose stool accidents for inactivating *Cryptosporidium*. This clarification also applies to Annex 13.8.