

A minerals research contract report
August 1981



**PROPAGATION OF EM SIGNALS
IN UNDERGROUND METAL/
NON-METAL MINES**

Contract J0308012
Terry S. Cory, P.E.

The views and conclusions contained in this document are those of the authors and should not be interpreted as representing the official policies or recommendations of the Interior Department's Bureau of Mines or of the U. S. Government.

REPORT DOCUMENTATION PAGE	1. REPORT NO.	2.	3. Recipient's Accession No.
4. Title and Subtitle		5. Report Date	
Propagation of EM Signals in Underground Metal/Non-Metal Mines		20 August, 1981	
7. Author(s)		6.	
Terry S. Cory and Richard J. Mahany		8. Performing Organization Rept. No.	
9. Performing Organization Name and Address		10. Project/Task/Work Unit No.	
Terry S. Cory, P.E. 2857 Mount Vernon Rd. S.E. Cedar Rapids, Iowa 52403		11. Contract(C) or Grant(G) No. (C) J0308012 (G)	
12. Sponsoring Organization Name and Address		13. Type of Report & Period Covered	
Office of the Assistant Director of Mining Bureau of Mines Department of the Interior, Washington D.C. 20241		Final Report 8-80 to 8-81	
14.		14.	
15. Supplementary Notes			
References: <u>Final Report</u> - Contract H0366028 "Propagation of EM Signals in Underground Mines"; and, <u>Final Report</u> - Contract H0377053 "Electromagnetic Propagation in Low Coal Mines at Medium Frequencies"			
16. Abstract (Limit: 200 words)			
<p>This report describes the results of a measurement and analysis program to characterize wireless radio transmission in metal/non-metal mines over a wide frequency range from 0.2 - 1000 MHz and over a variety of mine environments. Six mines were chosen based on the relative economic significance of their product to the U.S. economy.</p> <p>Mine types include oil shale, uranium, potash, lead/zinc, copper, and silver. Particular mines were chosen so that the group would embody the most important mining techniques.</p> <p>The results show that transmission at medium frequencies are optimum for wireless mine communications, in agreement with extensive testing previously performed by the authors in coal mines, and that mine-wide wireless systems are feasible with a minimum requirement for new dedicated wiring. At least one need for such a wireless system was identified in each mine visited.</p>			
17. Document Analysis			
a. Descriptors			
mine communications, wireless radio transmission, MF-UHF frequencies electromagnetic waves, inductive coupling			
b. Identifiers/Open-Ended Terms			
c. COSATI Field/Group			
18. Availability Statement		19. Security Class (This Report)	21. No. of Pages
		Unclassified	264
		20. Security Class (This Page)	22. Price
		Unclassified	

FOREWARD

This report was prepared by Terry S. Cory, P.E., Cedar Rapids, Iowa under USBM Contract number JO308012. The contract was initiated under the Coal Mine Health and Safety Program. It was administered under the technical direction of PRC with Mr. James R. Means, Jr. acting Technical Project Officer. Mr. Alan G. Bolton, Jr. was the contract administrator for the Bureau of Mines. This report is a summary of the work recently completed as a part of this contract during the period August 1980 to August 1981. This report was submitted by the authors on August, 1981.

References to specific brands, equipment, or trade names in this report are made to facilitate understanding and do not imply endorsement by the Bureau of Mines.

No patentable concepts of items of technology have resulted from the work performed under this contract.

Table of Contents

	Page
Report Documentation Page -----	1
Forward -----	2
Table of Contents -----	3
List of Illustrations -----	5
List of Tables -----	19
1.0 Executive Summary-----	24
1.1 Overview of Results-----	24
1.2 Application Possibilities-----	28
1.3 Areas For Further Work-----	31
2.0 Introduction -----	32
2.1 Background - Statement of the Problem -----	32
2.2 Metal/Non-Metal Mining Operations Summary -	33
2.2.1 Occidental Oil Shale, Inc. Logan Wash Mine-	37
2.2.2 United Nuclear/Homestake Partners Section	
23 Mine -----	39
2.2.3 Kerr-McGee Chemical Corp. Hobbs Potash	
Facility Mine -----	41
2.2.4 Amax Lead Co. of Missouri Buick Mine -----	43
2.2.5 Magma Copper Co. San Manuel Mine -----	45
2.2.6 Hecla Mining Co. Con-Sil Mine -----	45
2.3 Definition of Communications Requirements -	46
2.3.1 Occidental Oil Shale Logan Wash Mine -----	47
2.3.2 United Nuclear/Homestake Partners Section	
23 Mine -----	47
2.3.3 Kerr-McGee Chemical Corp. Hobbs Potash	
Mine Facility -----	47
2.3.4 Amax Lead Co. of Missouri Buick Mine -----	48
2.3.5 Magma Copper Co. San Manuel Mine -----	49
2.3.6 Hecla Mining Co. Con-Sil Mine -----	50
2.4 Outline of Performed Work -----	51
2.5 Report Contents -----	52
2.6 Definitions of Report Terms, Conventions	
And Nomenclature-----	53
2.6.1 Frequency Ranges-----	53
2.6.2 Loop Antenna Orientations-----	53
2.6.3 Monofilar Excitation-----	54
3.0 Technical Approach -----	56
3.1 Test System Characterization -----	56
3.1.1 Test System Descriptions -----	56
3.1.2 Test and Practical System Characteristics -	66
3.2 Categorization of Tests & Test Environments	69
3.2.1 Occidental Oil Shale Logan Wash Mine -----	69
3.2.2 United Nuclear/Homestake Partners Section	
23 Mine -----	77

3.2.3	Kerr-McGee Chemical Corp. Hobbs Potash Facility Mine -----	86
3.2.4	Amax Lead Co. of Missouri Buick Mine -----	89
3.2.5	Magma Copper Co. San Manuel Mine -----	96
3.2.6	Hecla Mining Co. Con-Sil Mine -----	100
3.3	System Performance Considerations -----	106
3.3.1	Low-Frequency Coupling Models -----	109
3.3.2	Intermediate Frequency Coupling & Attenuation -----	115
3.3.3	Waveguide Transmission -----	119
4.0	Individual Mine Reduced Test Data -----	121
4.1	Reduced Data From Occidental Oil Shale Logan Wash Mine -----	121
4.2	Reduced Data From United Nuclear/Homestake Partners Section 23 Mine -----	121
4.3	Reduced Data From Kerr-McGee Hobbs Potash Facility Mine -----	149
4.4	Reduced Data From Amax Lead Co. Of Missouri Buick Mine -----	149
4.5	Reduced Data From Magma Copper Co. San Manuel Mine -----	149
4.6	Reduced Data From Hecla Mining Co. Con-Sil Mine -----	183
5.0	Presentation of Raw Swept-Frequency Data --	206
5.1	Raw Data From Occidental Oil Shale Corp. Logan Wash Mine -----	206
5.2	Raw Data From United Nuclear/Homestake Partners Section 23 Mine -----	214
5.3	Raw Data From Kerr-McGee Chemical Corp. Hobbs Potash Facility Mine -----	222
5.4	Raw Data From Amax Lead Co. Of Missouri Buick Mine -----	231
5.5	Raw Data From Magma Copper Co. San Manuel Mine -----	238
5.6	Raw Data From Hecla Mining Co. Con-Sil Mine	254

List of Illustrations

Figure		Page
1	Mine Wireless Transmission Attenuation vs Frequency For Mines Visited @ 1000 Foot Range - Monofilar Line Attenuation and Waveguide Refractive/Roughness Losses ---	26
2	Unattenuated Magnetic Field Strength At Drift Center Due to Drift Center Excitation of Mine Wiring in Monofilar Mode for 1-Watt Transmitter for Flat NIA of -2 DB -----	27
3	Instantaneous Common Mode Noise Levels Interpreted as Phone Line Noise Currents and Electromagnetic Field Strength at 2-Meter Spacing From Phone Line -----	29
4	Medium-Frequency (MF) Swept-Frequency Test System Equipment Configuration -----	57
5	High-Frequency (HF) Swept-Frequency Test System Equipment Configuration -----	58
6	Very-High-Frequency (VHF) Swept-Frequency Test System Equipment Configuration -----	59
7	Ultra-High-Frequency (UHF) Swept-Frequency Test System Equipment Configuration -----	60
8	Microwave CW Test System Equipment Configuration -----	65
9	Multi-Turn Loop Antenna NIA Characteristics vs Frequency for 1-Watt of Transmit Power Sized for Portable and/or Vehicular Operation -----	67
10	Calculated Practical I_h for VHF for Fixed Electric Whip Antenna Length of 0.375 Meters and for 1-Watt of Transmitter Power -	68
11	Test and Practical System Geometric Current Moments for Induction Field -----	73
12	Test and Practical System Radiation Current Moments for 1-Watt Transmitter -----	74

13	Test System Receive Sensitivity Levels Determined on a Computed Basis -----	75
14	Occidental Oil Shale Logan Wash Mine Swept Frequency Measurement Locations -----	76
15	Occidental Oil Shale Logan Wash Mine VHF/UHF CW Field Strength Measurement Locations -----	78
16	Occidental Oil Shale Logan Wash Mine Medium Frequency CW Field Strength Measurement Locations -----	79
17	Occidental Oil Shale Logan Wash Mine Loop Excited Monofilar Mode 650KHZ Field Strength Measurement Locations -----	80
18	Occidental Oil Shale Logan Wash Mine Current Probe Excited Monofilar Mode 650KHZ Field Strength Measurement Locations -----	81
19	United Nuclear/Homestake Partners Section 23 Mine Map Showing Main Swept Measurement TX and RX Test Locations and MF Coupled Phone Line Receive Locations (MF Coupled Probe at TX Location in Wagner Drift) -----	82
20	United Nuclear/Homestake Partners Section 23 Mine Map Showing MF Coupled Phone Line RX Locations (MF Coupled Probe at TX Location in Wagner Drift) -----	83
21	United Nuclear/Homestake Partners Section 23 Mine Map of Wagner Area Showing Principal Swept Frequency TX & RX Locations, Plus RX Locations for CW VHF Tests & MF Coupled Power Line Tests -----	84
22	United Nuclear/Homestake Partners Section 23 Mine Map of Wagner Area Showing RX Locations for CW VHF Tests & MF Coupled Power Line Tests -----	85
23	United Nuclear/Homestake Partners Section 23 Mine Wagner Drift Cross-section Between Primary Swept Frequency TX and RX Locations, Floor Assumed to be Flat -----	87

24	Kerr-McGee Hobbs Potash Facility Area 140 Mine Map Showing Swept Frequency Field Strength Measurement Locations (100KHZ - 1000MHZ) -----	88
25	Kerr-McGee Hobbs Potash Facility Area 140 Mine Map Showing Medium Frequency Continuous Wave Field Strength Measurement Location (250KHZ, 650KHZ and 950KHZ) -----	90
26	Kerr-McGee Hobbs Potash Facility Area 140 Room 225 Mine Map Showing UHF Continuous Wave Field Strength Measurement Locations (600MHZ and 900MHZ) -----	91
27	Kerr-McGee Hobbs Potash Facility Mine Map Showing Locations of Conductor-Enhanced 650KHZ Field Strength Measurement Locations and 10GHZ Microwave Field Strength Measurement Locations -----	92
28	Map of North Mine Leg of Amax Buick Mine Showing Transmit and Receive Locations Used During Measurements With Transmit Locations for CW & Swept Range Tests Shown -----	94
29	Map of North Mine Leg of Amax Buick Mine Showing Transmit and Receive Locations Used During Measurements With Transmit Location for Swept-Frequency Tests Shown-----	95
30	Mine Map of 2375 Haulage Level of the Magma Copper Mine Showing Locations Employed on the Measurement Traverses for Evaluating the MSA 1680*Carrier Phone Performance -----	97
31	Drift Cross-sectional Geometries Encountered During Swept-Frequency Measurements in the Magma Copper Co. San Manuel Mine Car-Cleaner Drift -----	98
32	Track Coupling Geometry for Swept-Frequency Measurements in Magma Copper Co. San Manuel Mine -----	99

* Reference to specific brands, equipment, or trade names in this report is made to facilitate understanding and does not imply endorsement by the Bureau of Mines.

33	Drift Cross-sectional Geometry Viewed in the Inby Direction Showing HMD Test Antenna Locations - Hecla Con-Sil Mine -----	102
34	Drift Cross-sectional Geometry Viewed in the Inby Direction Showing VMD Test Antenna Locations - Hecla Con-Sil Mine -----	103
35	Mine Map of Hecla Mining Co. Con-Sil Mine Showing Swept-Frequency Test Locations -----	104
36	Mine Map of Hecla Mining Co. Con-Sil Mine Showing CW and Talk Test Locations -----	105
37	Summary of Wireless Transmission Magnetic Field Strength Characteristics Obtained in Mines #1, #2 and #3; 1 Watt Transmit Power-	110
38	Summary Wireless Transmission Magnetic Field Strength Characteristics Obtained in Mines #4, #5 and #6; 1 Watt Transmit Power -----	111
39	Geometries of Cases for 1/R Magnetic Field Fall-Off -----	113
40	Monofilar Track Coupling Model Geometry ----	114
41	MF/HF Characterization of Track as a Monofilar Conductor Comparing Computed Currents Derived from Magnetic Field Strength Data - Magma Copper Co. San Manuel Mine - 1 Watt Transmit Power -----	116
42	Geometry for Intermediate Frequency Coupling	117
43	Swept-Frequency MF/HF Measurements in North Mine With Tx at Y and With Rx at 064 Ore Pass 390 Feet Away - Amax Lead Co. Buick Mine	118
44	Illustration of Monofilar Coupling Effects Including Attenuation, Phase Cancellation and Impedance -----	120
45	Occidental Oil Shale Logan Wash Mine Retort #6 Area - Medium Frequency Swept Field Strength Measurements at Two Fixed Ranges 1 Watt Power into Practical Man-Pack Loop Antenna Characterization - Conductor-Free --	122

46	Occidental Oil Shale Logan Wash Mine Retort #6 Area - High Frequency Swept Field Strength Measurements at 120 Feet Ranges 1 Watt Power into Practical Man-Pack Loop Antenna Characterization Conductor-Free ----	123
47	Occidental Oil Shale Logan Wash Mine Retort #6 Area - VHF Swept Frequency Field Strength Measurements at Two Fixed Ranges - 1 Watt Power into Practical Man-Pack Whip Antenna Characterization Conductor-Free -----	124
48	Occidental Oil Shale Logan Wash Mine Retort #6 Area - UHF Swept Field Strength Measurements at 240 Feet Range - 1 Watt Power into Practical Man-Pack Whip Antenna Characterization Conductor-Free -----	125
49	Occidental Oil Shale Logan Wash Mine Retort #6 Area - VHF/UHF Vertical Wave Guide Mode (Horizontal Antennas) - 1 Watt Power into Practical Man-Pack Whip Antenna Characteri- zation - CW Tests -----	126
50	Loop-Excited MF Monofilar Mode Propagation Field Strength Measurements for 1 Watt Transmit Power into a Practical Man-Carried Loop Antenna Located Twenty Feet from the Local Conductors (650 KHZ Signal) - Logan Wash Mine -----	128
51	Current Probe Coupled MF Monofilar Mode Propagation Measurement Using a Pager Phone Cable and 1.2 Watts Transmit Power at 650 KHZ - Logan Wash Mine -----	130
52	Microwave Frequency Field Strength Measurements (10 GHZ) - Logan Wash Mine ----	131
53	Comparison of Computed and Measured Medium Frequency Swept-Frequency Data Taken in the Wagner Area of Section 23 Mine for Both Current Probe and Wireless Excited Modes of Transmission via Coupling into 480 VAC Line for 1 Watt Transmit Power and 180 Foot Range	133

54	Comparison of Computed and Measured Medium Frequency Swept-Frequency Data Taken in the 650 Track Area of Section 23 Mine for Both Current Probe and Wireless Excited Modes of Transmission via Coupling into a Conductor Ensemble, Probe Attached to the Phone Line for 1 Watt Transmit Power at 180 Foot Range --	134
55	High-Frequency Swept-Frequency Data Taken in Wagner Area of Section 23 Mine for Both Current Probe and Wireless Excited Modes of Transmission via Coupling into 480 VAC Line for 1 Watt Transmit Power at 180 Foot Range --	136
56	VHF Swept-Frequency Data Taken in Wagner Area of United Nuclear Section 23 Mine for Several Polarization Orientations of Biconical Test Antennas - Normalized for 1-Watt into Practical Man-Pack Whip Antenna Characterization at 180 Foot Range -----	138
57	VHF Swept-Frequency Data Taken in 650 Track Area of United Nuclear Section 23 Mine for Several Polarization Orientations of Biconical Test Antennas - Normalized for 1-Watt into Practical Man-Pack Whip Antenna Characterization at 180 Foot Range -----	139
58	UHF Swept-Frequency Data Taken in Wagner Area of Section 23 Mine for Both Principal Polarizations of the Log-Periodic Test Antennas Normalized for 1 Watt into Practical Man-Pack Whip Antenna Characterization at 180 Foot Range -----	142
59	UHF Swept-Frequency Data Taken in 650 Track Area of Section 23 Mine for both Principal Polarizations of the Log-Periodic Test Antenna - Normalized for 1 Watt into Practical Man-Pack Whip Antenna Characterization at 180 Foot Range -----	143
60	Processed MF and HF Data From Wagner Area of United Nuclear Section 23 Mine at 180 Foot Test Range for Flat NIA of -2dB -----	150

61	Kerr-McGee Hobbs Potash Facility Mine Area 140 - BT#3 Medium Frequency Swept Field Strength Measurements at Two Fixed Ranges - 1 Watt Power into Practical Man-Pack Loop Antenna Characterization with Conductors Present -----	152
62	Kerr-McGee Hobbs Potash Facility Mine Area 140-BT#3 High Frequency Swept Field Strength Measurements at 300 Feet Range 1 Watt Power into Practical Man-Pack Loop Antenna Charac- terization with Conductors Present -----	153
63	Kerr McGee Hobbs Potash Facility Mine Area 140-BT#3 VHF Swept Field Strength Measure- ments at two Fixed Ranges - 1 Watt Transmit Power into Practical Man-Pack Whip Antenna Characterization with Conductors Present -----	154
64	Kerr-McGee Hobbs Potash Facility Mine Area 140-BT#3 UHF Swept Field Strength Measure- ments into a Practical Man-Pack Whip Antenna 150 Feet Range -----	155
65	Current Probe Medium Frequency Field Strength Measurements at 300 Feet Range Kerr-McGee Hobbs Potash Facility Mine Area 140-BT#3 Including Both Empirical and Theoretical Data-	156
66	Kerr-Mcgee Hobbs Potash Facility Mine Area 140-BT#3 Medium Frequency Continuous Wave Field Strength Measurements vs. Range 1 Watt Power into Practical Man-Pack Loop Antennas With Conductor Enhancement 250KHz, 650 KHz and 950 KHz -----	157
67	Kerr-McGee Hobbs Potash Facility Mine 650 KHz Conductor Enhanced Field Strength Measurement Data 1 Watt Transmit Power into Practical Vehicular Antenna Characterization -----	159
68	Kerr-McGee Hobbs Potash Facility Mine Room 225/Area 140 UHF Continuous Wave Field Strength Measurements (600MHz and 950 MHz) For 1 Watt Transmit Power into Practical Whip Antennas -----	161

69	Processed MF and HF Data From Kerr-McGee Potash Mine on 150-Foot Test Range for Flat NIA of -2dB With and Without Attenuation -----	163
70	Magnetic Field Strength vs Range along North Mine Tracked Haulageway for 1 - Watt Transmitter Loop-Coupled Into Dedicated Wire at 50-450 KHz - Amax Lead Co. Buick Mine -----	164
71	Magnetic Field Strength vs Range Along North Mine Tracked Haulageway for 1 - Watt Transmitter Loop-Coupled into Dedicated Wire at 550-950 KHz Amax Lead Co. Buick Mine -	165
72	Magnetic Field Strength VS Range Along North Mine Tracked Haulageway for 15 - Watt Transmitter Loop-Coupled into Dedicated Wire or Phone Line Using Collins Prototype Base Station in Foreman's Shack - 520 KHz Amax Lead Co. Buick Mine -----	168
73	Swept-Frequency MF/HF Measurements in North Mine with TX at Y and with RX at 064 Ore Pass 390 Feet Away RX Antenna 1 Meter Below Conductors Amax Lead Co. Buick Mine -----	170
74	Swept-Frequency MF/HF Measurements in North Mine with TX at Y and with RX at 049 Ore Pass 1290 Feet Away - 1 Watt Transmit Power RX Antenna 1 Meter Below Conductors - Amax Lead Co. Buick Mine -----	173
75	Swept-Frequency VHF/UHF Measurements in North Mine with TX at Y and with RX at 064 Ore Pass 390 Feet Away - 1 Watt Transmit Power into Practical Whip Antennas -Amax Lead Co. Buick Mine -----	176
76	Processed MF and HF Data from Amax Lead Co. Buick Mine on 390-Foot Test Range for Flat NIA of -2 DB With and Without Attenuation ---	179
77	MF/HF Characterization of Track as a Monofilar Conductor Comparing Computed Currents and Currents Derived From Magnetic Field Strength Data - Magma Copper Co. San Manuel Mine -----	180

78	Computed MF/HF Monofilar Mode Track Coupling Corresponding to Car-Cleaner Drift Measurements - Magma Copper Co. San Manuel Mine -----	184
79	Swept-Frequency VHF Reduced Data For Practical Whip Antennas Taken in Car-Cleaner Tracked Drift at a Range of 111 Feet from the Transmitter - 1 Watt Transmit Power Magma Copper Co. San Manuel Mine -----	185
80	Swept-Frequency UHF Reduced Data Taken in Car-Cleaner Tracked Drift at a Range of 243 Feet from the Transmitter For Practical Whip Antennas - Magma Copper Co. San Manuel Mine - 1 Watt Transmit Power -----	186
81	Test System Reduced MF Data Expressed as Monofilar Mode Current from Carrier Phone Testing on Base-Vehicles and Vehicle-Base Paths at 145KHz abd 520KHz Respectively - Magma Copper Co. San Manuel Mine - 1 Watt Transmit Power -----	187
82	Reduced Data Expressed as Monofilar Mode Current Levels on Vehicle-Base Path at 520 KHz Differentiating Between Current Received in Radio Shop and that Expected on the Trolley Conductor System - Magma Copper Co. San Manuel Mine -----	189
83	Processed MF and HF Data from Magma San Manuel Mine on 243-Foot Test Range for Flat NIA of -2 DB for HMD and VMD Antenna Orientations - 1 Watt Transmit Power and Test System Antennas -----	191
84	Reduced Magnetic Field Strength Data at MF/HF Taken on 429 Foot Path in 3000- Level North Crosscut Hecla Con-Sil Mine -----	192
85	Reduced Data Expressed as Monofilar Line Current Normalized to NIA-Unity Taken on 429 Foot Path in 3000-Level North Crosscut Hecla Con-Sil Mine -----	197

86	Reduced Electric Field Strength Data for VHF/UHF Horizontal Polarization Taken in 3000-Level North Crosscut on a 195 Foot Path (Location 2) - 1 Watt Transmit - Practical Whip Antennas - Hecla Con-Sil Mine -----	198
87	Reduced Electric Field Strength Data for VHF/UHF Vertical Polarization Taken in 3000-Level North Crosscut on a 195 Foot Path (Location 2) - 1 Watt Transmit Power Practical Whip Antennas - Hecla Con-Sil Mine -----	199
88	Reduced CW MF Magnetic Field Strength Data Taken in Direction of Sunshine Raise From Both Test Set and Collins 1-Watt Radios - Hecla Con-Sil Mine -----	202
89	Reduced Magnetic Field Strength Data Taken on 3000-Level Toward Con-Sil Winze Using Collins 520KHz FM Radio and 650KHz Test Set - 1 Watt Transmitters - Hecla Con-Sil Mine -----	203
90	Processed MF and HF Data from Hecla Con- Sil Mine on 429-Foot Test Range for Flat NIA of -2 DB With and Without Attenuation - Data Obtained Using Test System Equipment -----	205
91	Medium Frequency Swept Field Strength Original Oscillographs - Logan Wash Mine -----	207
92	High Frequency Swept Field Strength Original Oscillographs - Logan Wash Mine -----	208
93	VHF Swept Frequency Field Strength Original Oscillographs - Logan Wash Mine -----	209
94	VHF Swept Frequency Field Strength Original Oscillographs - Logan Wash Mine -----	210
95	VHF Swept Frequency Field Strength Original Oscillographs - Logan Wash Mine -----	211
96	UHF Swept Frequency Field Strength Original Oscillographs - Logan Wash Mine -----	212

97	UHF Swept Frequency Field Strength Original Oscillographs - Logan Wash Mine -----	213
98	Original Oscillographs of MF Swept Frequency Data Taken in Wagner Area of United Nuclear Section 23 Mine -----	215
99	Original Oscillographs of MF Swept Frequency Data Taken in 650 Track Area of United Nuclear Section 23 Mine -----	216
100	Original Oscillographs of HF Swept Frequency Data Taken in Wagner Area of Section 23 Mine -----	217
101	Original Oscillographs of VHF Swept Frequency Data Taken in Wagner Area of United Nuclear Section 23 Mine -----	218
102	Original Oscillographs of VHF Swept Frequency Data Taken in 650 Track Area of United Nuclear Section 23 Mine -----	219
103	Original Oscillographs of UHF Swept Frequency Data Taken in Wagner Area of United Nuclear Section 23 Mine -----	220
104	Original Oscillographs of UHF Swept Frequency Data Taken in 650 Track Area of United Nuclear Section 23 Mine -----	221
105	Medium Frequency Swept Field Strength Original Oscillographs - Kerr McGee Hobbs Potash Facility - 150 Feet Range -----	223
106	Medium Frequency Swept Field Strength Original Oscillographs - Kerr McGee Hobbs Potash Facility - 300 Feet Range -----	224
107	High Frequency Swept Field Strength Original Oscillographs - Kerr McGee Hobbs Potash Facility - 150 Feet Range -----	225
108	High Frequency Swept Field Strength Original Oscillographs - Kerr McGee Hobbs Potash Facility - 300 Feet Range -----	226
109	VHF Swept Frequency Field Strength Original Oscillographs - Kerr McGee Hobbs Potash Facility - 150 Feet Range -----	227

110	VHF Swept Frequency Field Strength Original Oscillographs - Kerr McGee Hobbs Potash Facility - 300 Feet Range -----	228
111	UHF Swept Frequency Field Strength Original Oscillographs - Kerr McGee Hobbs Potash Facility - 150 Feet Range -----	229
112	Medium Frequency Swept Field Strength Original Oscillographs - Kerr McGee Hobbs Potash Facility - 300 Feet Range - Current Probe Excitation -----	230
113	Original Oscillographs of MF Swept Frequency Data at 064 Ore Pass; Tx @ North Mine Y - Amax Lead Co. Buick Mine -----	232
114	Original Oscillographs of HF Swept Frequency Data at 064 Ore Pass; Tx @ North Mine Y - Amax Lead Co. Buick Mine -----	233
115	Original Oscillographs of MF Swept Frequency Data at 049 Ore Pass; Tx at North Mine Y - Amax Lead Co. Buick Mine -----	234
116	Original Oscillographs of HF Swept Frequency Data at 049 Ore Pass; Tx at North Mine Y - Amax Lead Co. Buick Mine -----	235
117	Original Oscillographs of VHF Swept Frequency Data Taken in the North Mine Tracked Haulageway at the 064 Ore Pass; Tx Located at Y - Amax Lead Co. Buick Mine -----	236
118	Original Oscillographs of UHF Swept Frequency Data Taken in the North Mine Tracked Haulageway at the 064 Ore Pass; Tx Located at Y - Amax Lead Co. Buick Mine --	237
119	Original Oscillographs of MF Swept Frequency Data Taken on Car-Cleaner Track Drift Magma Copper Co. San Manuel Mine -----	239
120	Original Oscillographs of HF Swept Frequency Data Taken on Car-Cleaner Track Drift Magma Copper Co. San Manuel Mine -----	240

121	Original Oscillographs of VHF Swept Frequency Data Taken in the Car-Cleaner Tracked Drift Magma Copper Co. San Manuel Mine -----	241
122	Original Oscillographs of UHF Swept Frequency Data Taken in the Car-Cleaner Tracked Drift Magma Copper Co. San Manuel Mine -----	242
123	Original Oscillographs from 520 KHz Carrier Phone Testing, Vehicle-Base Locations A-C Magma Copper Co. San Manuel Mine -----	243
124	Original Oscillographs from 520 KHz Carrier Phone Testing, Vehicle-Base Locations D-G Magma Copper Co. San Manuel Mine -----	244
125	Original Oscillographs from 520 KHz Carrier Phone Testing, Vehicle-Base Locations G-J Magma Copper Co. San Manuel Mine -----	245
126	Original Oscillographs from 520 KHz Carrier Phone Testing, Vehicle-Base Locations K-M Magma Copper Co. San Manuel Mine -----	246
127	Original Oscillographs from 520 KHz Carrier Phone Testing, Vehicle-Base Locations N-Q Magma Copper Co. San Manuel Mine -----	247
128	Original Oscillographs from 520 KHz Carrier Phone Testing, Vehicle-Base Locations R-S Magma Copper Co. San Manuel Mine -----	248
129	Original Oscillographs from 520 KHz Carrier Phone Testing, Vehicle-Base Locations T-V Magma Copper Co. San Manuel Mine -----	249
130	Original Oscillographs from 520 KHz Carrier Phone Testing, Vehicle-Base Locations W-X Magma Copper Co. San Manuel Mine -----	250
131	Original Oscillographs from 145 KHz Carrier Phone Testing, Base-Vehicle Locations G-K Magma Copper Co. San Manuel Mine -----	251
132	Original Oscillographs from 145 KHz Carrier Phone Testing, Base-Vehicle Locations M-Q Magma Copper Co. San Manuel Mine -----	252

133	Original Oscillographs from 145 KHz Carrier Phone Testing, Base-Vehicle Locations Q-X Magma Copper Co. San Manuel Mine -----	253
134	Original Oscillographs of MF Swept Frequency Data Taken Along 3000-Level North Crosscut HMD & Probe Configurations - Hecla Con-Sil Mine --	255
135	Original Oscillographs of MF Swept Frequency Data Taken Along 3000-Level North Crosscut VMD Configurations - Hecla Con-Sil Mine -----	256
136	Original Oscillographs of HF Swept Frequency Data Along 3000-Level North Crosscut - HMD and Probe Configurations w/o Frequency Index Reference - Hecla Con-Sil Mine -----	257
137	Original Oscillographs of HF Swept Frequency Data Along 3000-Level North Crosscut - VMD Configurations w/o Frequency Index Reference - Hecla Con-Sil Mine -----	258
138	Original Oscillographs of HF Swept Frequency Data Along 3000-Level North Crosscut - Probe and VMD Configurations with Frequency Index Reference - Hecla Con-Sil Mine -----	259
139	Original Oscillographs of VHF Swept Frequency Data Along 3000-Level North Crosscut with Antennas at Drift Center at Location 1 Hecla Con-Sil Mine -----	260
140	Original Oscillographs of VHF Swept Frequency Data Along 3000-Level North Crosscut with Antennas at Drift Center at Location 2 Hecla Con-Sil Mine -----	261
141	Original Oscillographs of UHF Swept Frequency Data Along 3000-Level North Crosscut with Antennas at Drift Center at Location 1 Hecla Con-Sil Mine -----	262
142	Original Oscillographs of UHF Swept Frequency Data Along 3000-Level North Crosscut with Antennas at Drift Center at Location 2 Hecla Con-Sil Mine -----	263

List of Tables

Table		Page
1	Estimated UHF Unattenuated Field Strengths for Selected Individual Mines for 1-watt Transmitter Power-----	28
2	MF & HF Magnetic Field Strength Correction Factors-----	70
3	VHF & UHF Electric Field Strength Correction Factors-----	71
4	Magnetic Field Strength Data Correction Factors for Use with Stoddard Current Probe-	72
5	Distances to Locations Along the Measurement Traverse on the 2375 Haulage Level-----	101
6	Distances to CW Locations on 3000-Level of Con-Sil Mine-----	107
7	VHF/UHF CW Field Strength Measurement Data - Logan Wash Mine-----	127
8	Loop Excited Monofilar Mode 650 KHz Field Strength Measurement Data - Logan Wash Mine-----	129
9	Microwave Field Strength Measurement Data - Logan Wash Mine-----	132
10	Reduced Swept-Frequency MF Data Taken in Wagner Area United Nuclear Section 23 Mine 1 Watt Transmit Power at 180 Foot Range ----	135
11	Reduced Swept-Frequency MF Data Taken in 650 Track Area United Nuclear Section 23 Mine - 1 Watt Transmit Power at 180 Foot Range -----	135
12	Reduced Swept-Frequency HF Data Taken in Wagner Area United Nuclear Section 23 Mine 1 Watt Transmit Power at 180 Foot Range ----	137
13	Reduced Swept-Frequency VHF Data Taken in Wagner Area United Nuclear Section 23 Mine 1 Watt Transmit Power at 180 Foot Range ----	140

14	Reduced Swept-Frequency VHF Data Taken in 650 Track Area of United Nuclear Section 23 Mine - 1 Watt Transmit Power at 180 Foot Range -----	141
15	Reduced Swept-Frequency UHF Data Taken in Wagner Area United Nuclear Section 23 Mine 1 Watt Transmit Power at 180 Foot Range -----	144
16	Reduced Swept-Frequency UHF Data Taken in 650 Track Area United Nuclear Section 23 Mine - 1 Watt Transmit Power at 180 Foot Range -----	144
17	CW Medium Frequency Data in Wagner Drift Area at 650 KHz United Nuclear Section 23 Mine -----	145
18	CW Medium Frequency Data Over Large Area from TX Located in Principal Wagner Area Location of United Nuclear Section 23 Mine with Coupling to Phone Line via Stoddard Current Probe at 650 KHz -----	146
19	CW VHF Data Taken in Wagner Drift Area United Nuclear Section 23 Mine -----	147
20	X- Band Microwave Test Data Taken in Wagner Area United Nuclear Section 23 Mine 1 Watt Transmit Power -----	148
21	Summary of Conductor Ensemble Impedances Deduced from Measurements United Nuclear Section 23 Mine -----	151
22	Medium Frequency Continuous Wave Field Strength Measurement Data Kerr-McGee Hobbs Potash Facility Mine Area 140-BT #3 1 Watt Transmit Power -----	158
23	Conductor-Enhanced Medium Frequency Continuous Wave Field Strength Measurements - Kerr McGee Hobbs Potash Facility - 650 KHz Test Frequency - 1 Watt Transmit Power -----	160

- 24 UHF Continuous Wave Field Strength Measurement Data Kerr-McGee Hobbs Potash Facility Mine Room 225 (Horizontal Antenna Polarization)-1 Watt Transmit Power- 162
- 25 Microwave Frequency Continuous Wave Field Strength Measurement Data Kerr-McGee Hobbs Potash Facility Room 27 West (1 Watt Transmit Power - 10 GHz) ----- 162
- 26 Reduced Magnetic Field Strength Data Taken on a Swept-Frequency Basis with Range Along the North Mine Tracked Haulage Drift Away From a 1-Watt Transmitter Loop-Coupled into the Dedicated Wire in the Foreman's Shack Amax Lead Co. Buick Mine----- 166
- 27 Results of MF CW Demonstration Testing at 520 KHz using Collins Prototype Base Station as the Transmitter in the Foreman's Shack and using a Singer Field Strength Meter plus a Portable Collins Unit Along the North Mine Tracked Haulage Drift - Amax Lead Co. Buick Mine --- 169
- 28 Reduced Magnetic Field Strength and Coupled Current Data Taken on a Swept-Frequency Basis at 064 Ore Pass from a 1 Watt Transmitter Located at the Northwest/ Northeast Y - Amax Lead Co. Buick Mine ----- 171
- 29 Reduced Magnetic Field Strength and Coupled Current Data taken on a Swept-Frequency Basis at 064 Ore Pass from a 1 Watt Transmitter Located at the Northwest/ Northeast Y - Amax Lead Co. Buick Mine ----- 172
- 30 Reduced Magnetic Field Strength and Coupled Current Data taken on a Swept-Frequency Basis at 049 Ore Pass from a 1 Watt Transmitter Located at the Northwest/ Northeast Y - Amax Lead Co. Buick Mine ----- 174
- 31 Reduced Magnetic Field Strength and Coupled Current HF Data Taken on a Swept-Frequency Basis at 049 Ore Pass from a 1 Watt Transmitter Located at the Northwest/ Northeast Y - Amax Lead Co. Buick Mine. ----- 175

32	Reduced VHF Electric Field Strength Data taken on a Swept-Frequency Basis along the North Mine Tracked Haulage Drift at 064 Ore Pass from a Transmitter Located at the Northwest/Northeast Y - 1 Watt Transmit Power for Practical Whip Antennas Amax Lead Co. Buick Mine -----	177
33	Reduced UHF Electric Field Strength Data taken on a Swept-Frequency Basis along the North Mine Tracked Haulage Drift at 064 Ore Pass from a Transmitter Located at the Northwest/Northeast Y - 1 Watt Transmit Power for Practical Whip Antennas - Amax Lead Co. Buick Mine -----	178
34	Reduced Magnetic Field Strength and Coupled Current Data taken on a Swept-Frequency Basis in the Car-Cleaner Track Drift Which Contained no other Significant Conductors at MF - 1 Watt Transmit Power Magma Copper Co. San Manuel Mine -----	181
35	Reduced Magnetic Field Strength and Coupled Current Data taken on a Swept-Frequency Basis in the Car-Cleaner Track Drift Which Contained no other Significant Conductors at HF - 1 Watt Transmit Power Magma Copper Co. San Manuel Mine -----	182
36	Reduced Data From 145 KHz Carrier phone Tests on the Base-Vehicle Linkage Along the Measurement Traverse - Magma Copper Co. San Manuel Mine - 1 Watt Transmit Power ----	188
37	Reduced Data from 520 KHz Carrier phone Tests on the Vehicle-Base Linkage along the Measurement Traverse - Magma Copper Co. San Manuel Mine -----	190
38	Reduced Magnetic Field Strength and Coupled Current Data taken on a Swept-Frequency Basis in the 3000 Level North Crosscut on a 429 Foot Path at MF for VMD Antenna Orientations - 1 Watt Transmit Power for Test System Antennas - Hecla Con-Sil Mine -----	193

39	Reduced Magnetic Field Strength and Coupled Current Data taken on a Swept- Frequency Basis in the 3000-Level North Crosscut on a 429 Foot Path at HF for HMD Antenna Orientations-1 Watt Transmit Power- Hecla Con-Sil Mine -----	194
40	Reduced Magnetic Field Strength and Coupled Current Data taken on a Swept- Frequency Basis in the 3000-Level North Crosscut on a 429 Foot Path at HF for VMD Antenna Orientations - 1 Watt Transmit Power - Hecla Con-Sil Mine -----	195
41	Reduced Magnetic Field Strength and Coupled Current Data Taken on a Swept- Frequency Basis in the 3000 Level North Crosscut on a 429 Foot Path a HF for HMD Antenna Orientations - 1 Watt Transmit Power - Hecla Con-Sil Mine -----	196
42	Reduced VHF Electric Field Strength Data Taken on a Swept-Frequency Basis on a 195 Foot Path in the 3000-Level North Crosscut - 1 Watt Transmit Power - Practical Whip Antennas - Hecla Con-Sil Mine -----	200
43	Reduced UHF Electric Field Strength Data Taken on a Swept-Frequency Basis on a 195 Foot Path in the 3000-Level North Crosscut - 1 Watt Transmit Power - Practical Whip Antennas - Hecla Con-Sil Mine -----	201
44	Reduced MF CW Magnetic Field Strength Data Taken on a Swept-Frequency Basis on a 195 Foot Path in the 3000-Level North Crosscut of Hecla Con-Sil Mine using 1 Watt Test System Equipment -----	204

1.0 EXECUTIVE SUMMARY

Wireless radio communication possibilities were assessed in six metal/non-metal mines representing a varied cross section of mine types having major economic significance. The assessment comprised both the electrical measurement and analysis of transmission characteristics and characterization of the operational utility achievable through the use of wireless communications. The measurement of characteristics was conducted over the frequency range of 0.2-1000 MHz using modern swept-frequency techniques.

Prior to this program, the feasibility and utility of wireless communications at medium frequencies (MF) in coal mines and at ultra-high frequencies (UHF) in large rock mines was established. Additionally, UHF leaky feeder systems requiring a special cable were implemented commercially in a variety of mine types. The results of this program show that MF transmission is feasible and optimum in all metal/non-metal mine drifts having existing wiring regardless of the area of the drift cross section. This result is contrary to that observed for UHF signals, where communications are restricted to mines with large drift cross sections, due to excessive refractive and roughness (scattering) losses incurred in small drifts.

As in coal mines, the use of MF frequencies provides the most viable basis for the implementation of mine-wide "wireless" communications. In most metal/non-metal mines, MF communications can be effectively used to streamline haulage operations and locate key underground supervisory and maintenance personnel. MF systems can also provide advance warning of impending health and safety problems in mine working areas where permanent mine wiring and fixed communications are not economically feasible.

Also, as in coal mines, the transmission of MF carrier current in existing mine wiring is observed to be minimally effected by details of the wireplant routing and terminations.

These findings are timely in view of joint ongoing USBM and industry sponsored development activities to produce mine-worthy MF wireless communications equipment.

1.1 OVERVIEW OF RESULTS

Based on characteristics of attenuation versus range, useful wireless transmission is limited to frequencies in the MF and HF bands from approximately 200KHz to 1MHz and in the UHF band above 200MHz to 400MHz. VHF frequencies were unusable in all of the visited mines.

The MF/HF attenuation was measured over all MF and HF frequencies in

two of the mines and over limited regions at MF in three others. Generally, the attenuation in drifts varied directly with frequency, with 6 dB/1000 feet at 1 MHz being representative of the observed attenuation in the visited mines. To achieve reasonable parity in UHF transmission in the mines, an operating frequency of at least 800 - 1000 MHz must be used. At a range of 1000 feet at these frequencies, the UHF signal levels are within 20 db of their unattenuated values. Figure 1 shows the composite attenuation data for all visited mines. The UHF data has been computed using the ADL model for refractive and roughness losses and the individual mine drift cross-sectional geometries. The low-frequency attenuation data is a composite of measured and computed values.

The use of MF frequencies has proven to be optimum for close-proximity inductive coupling. Previous data from coal mines has verified MF to be optimum for both direct through-the-seam and remote proximity coupling to mine wiring. Prior to this program, the coupling loss was thought to decrease monotonically with frequency through at least most of the HF region for close-proximity coupling. The results of this program have disproven this hypothesis and have confirmed that optimum coupling is restricted to the MF range. The models developed to account for these effects are equally applicable to coal and metal/non-metal mines. The precise "round trip" coupling was determined to be a function of coupling geometry in the drift cross section (where "round trip" is defined as the field strength incident on a receiving antenna in a drift due to an inductively coupled transmit antenna source).

The unattenuated "round trip" coupling for a 1-watt transmitter with NIA of -2 dB (below unity) for transmit and receive antennas located at the drift centers is shown in Figure 2. This figure illustrates several of the variables related to coupling geometry. A curve of receive system sensitivity is also included so that estimates of system dynamic range and "allowable attenuation" can be made when combined with an estimate of the external noise environment of a particular mine. The low-frequency coupling (providing the monotonic coupling increase with frequency) varied over a range of about 20 dB due to: the separation of antennas from the conductors; the proximity of the conductors to nearby conducting surfaces; and, to variations in the conductor ensemble driving point impedance. The intermediate frequency performance is effected by the separation of the antennas from the conductors and the phase velocity and standing wave conditions on the monofilar or bifilar line(s) formed by the excited conductors. Generally, the coupling roll-off in the intermediate (largely HF) frequency region is due to phase shifts along the line(s) over the coupling region of the antenna. If the coupling region is large (as in a large drift crossection with attendant larger separation between antennas and conductors) the roll-off is extremely rapid with the coupling approaching a limit 20-30 dB below the optimal

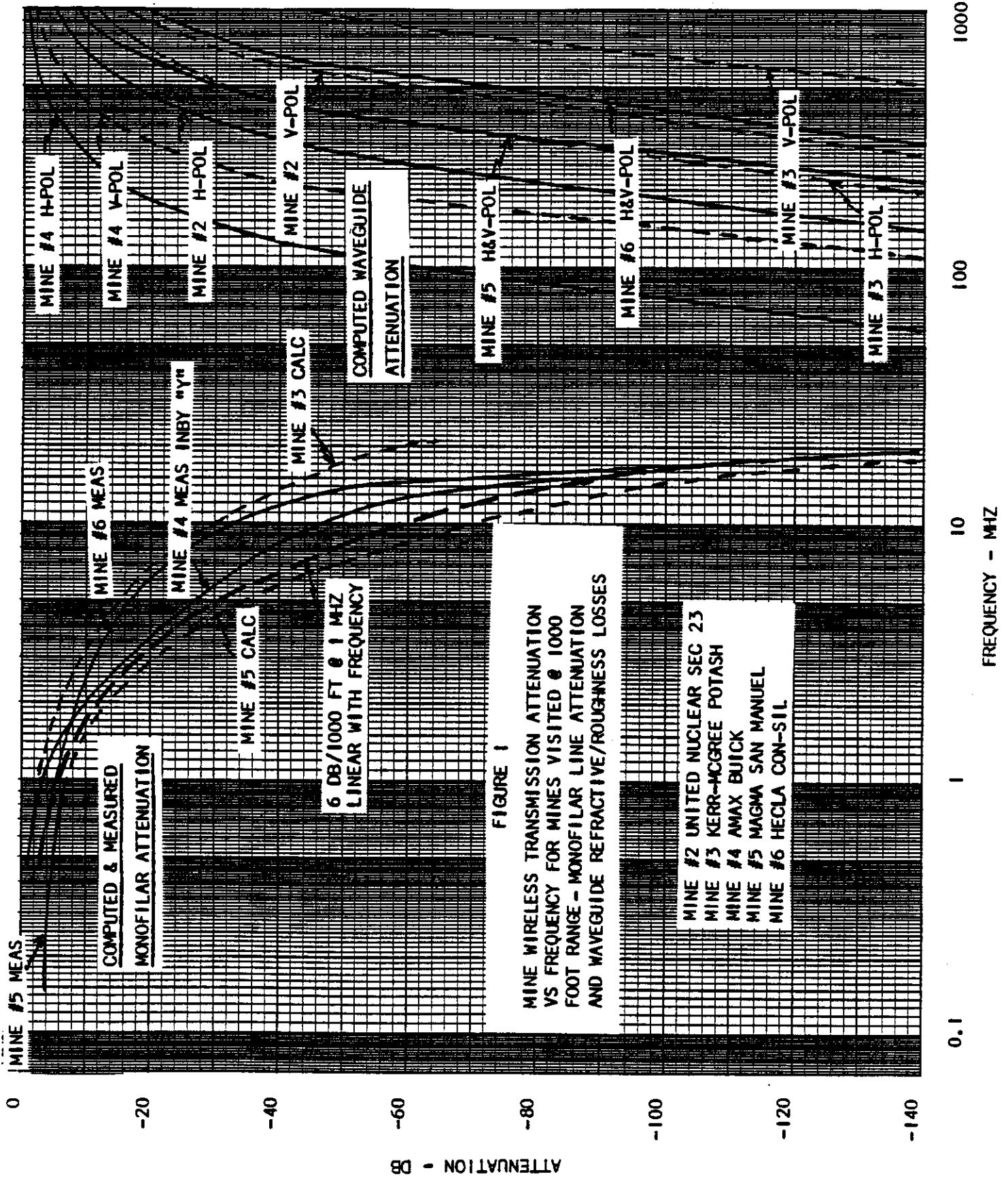

FIGURE 1

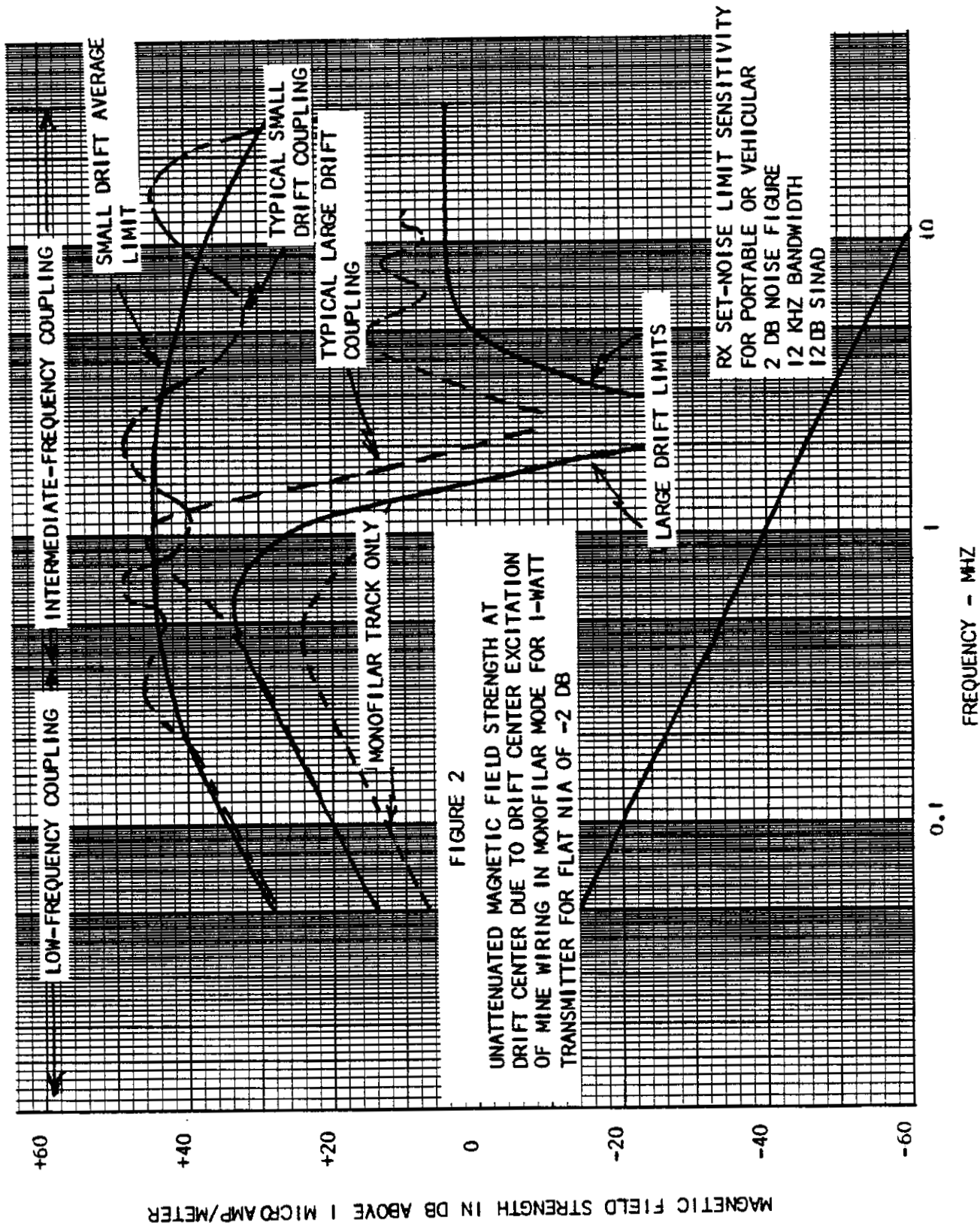

FIGURE 2
 UNATTENUATED MAGNETIC FIELD STRENGTH AT
 DRIFT CENTER DUE TO DRIFT CENTER EXCITATION
 OF MINE WIRING IN MONOFILAR MODE FOR 1-WATT
 TRANSMITTER FOR FLAT NIA OF -2 DB

RX SET-NOISE LIMIT SENSITIVITY
 FOR PORTABLE OR VEHICULAR
 2 DB NOISE FIGURE
 12 KHZ BANDWIDTH
 12 DB SINAD

MAGNETIC FIELD STRENGTH IN DB ABOVE 1 MICRAMP/METER

MF coupling level. If the coupling range is short and/or the line phase velocity approaches free space values (due to back or ribs covered with metal mesh) the roll-off is more gradual. The data presented in the figure is normalized for an assumed flat NIA which is increasingly difficult to achieve above the MF band, for the fixed antenna size and transmit power limitations of practical systems. A practical NIA characterization (based on the forementioned limitations) given in Section 3.0 shows an approximate 1/f NIA fall-off above about 2 MHz, which further optimizes the MF region for coupling.

A chart of observed mine noise values is given in Figure 3, which may be used in conjunction with the preceding figures to enable estimates of signal margin for systems deployed in these mines. Additionally, estimates of the unattenuated UHF signal levels at about 1000 MHz are given below in Table 1.

TABLE 1
ESTIMATED UHF UNATTENDED FIELD STRENGTHS FOR
SELECTED INDIVIDUAL MINES FOR 1-WATT TRANSMITTER POWER
USING LOG PERIODIC ANTENNA

MINE #	ELECTRIC FIELD STRENGTH dB ABOVE 1 MICRO-VOLT/M	MAGNETIC FIELD STRENGTH dB ABOVE 1 MICRO-AMP/M
2	+104	+52
3	+122 H-POL	+72
	+152 V-POL	+101
4	+116	+64
5	+101	+49
6	+122	+70

Detailed test data from each mine including continuous wave field strength measurements with range at or near optimum frequencies is given in Section 4.0. Some continuous wave microwave test data at 10 GHz was also gathered during this program. This data, also included in Section 4.0, has little apparent significance and is not elaborated upon in this report.

1.2 APPLICATION POSSIBILITIES

The simplest application is the implementation of one-way voice or tone paging from a central dispatch location using existing mine wiring, with key supervisory and/or maintenance personnel carrying pocket pagers. Alternative "page" or "alert" applications might include an alarm system with alarm receivers at critical fixed locations within audible range of working areas. Such systems are faster and more accurate than existing power interruption or stench warning systems.

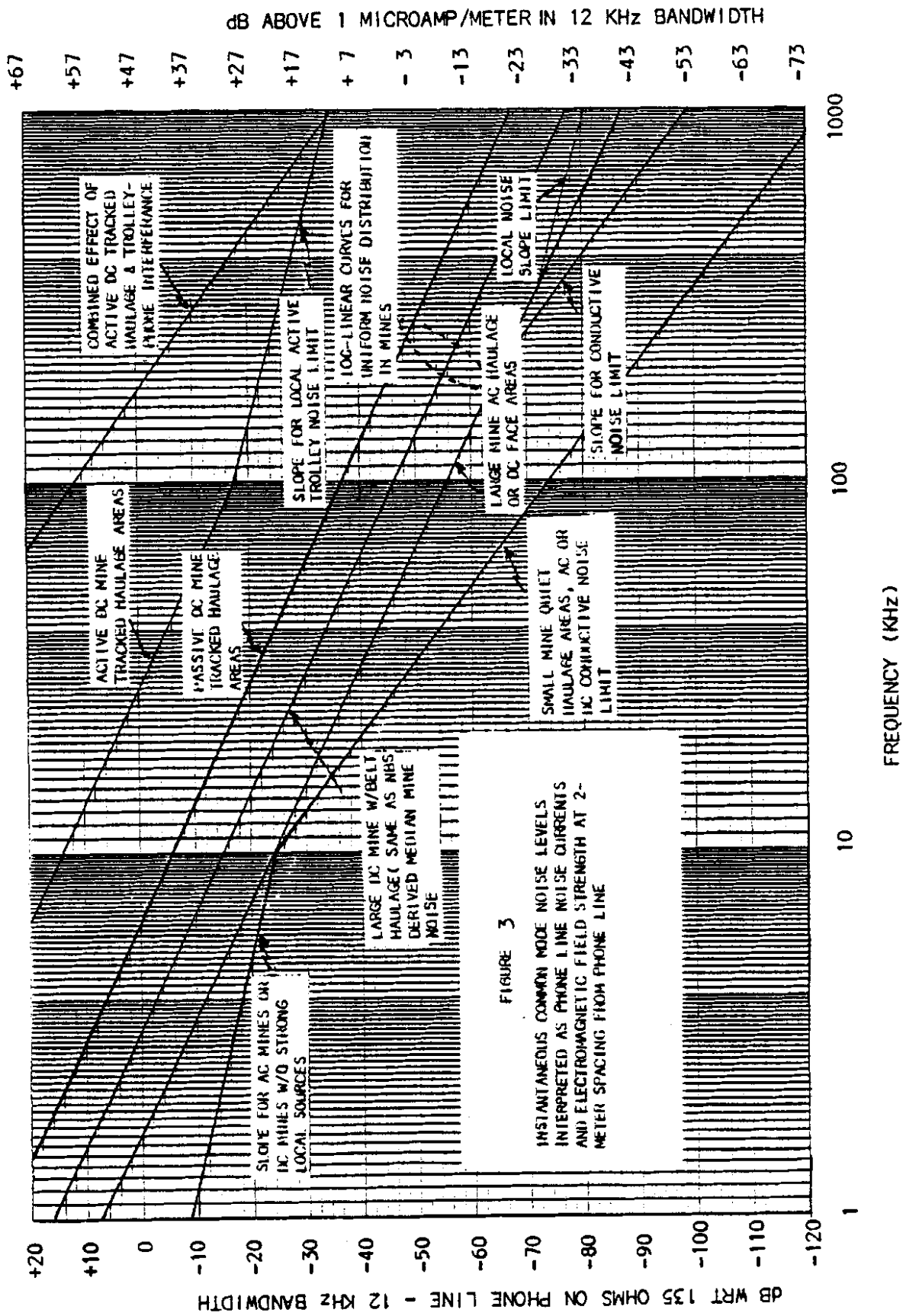

FIGURE 3

INSTANTANEOUS COMMON MODE NOISE LEVELS INTERPRETED AS PHONE LINE NOISE CURRENTS AND ELECTROMAGNETIC FIELD STRENGTH AT 2-METER SPACING FROM PHONE LINE

The most useful application is providing two-way voice communications from a fixed dispatch location to mobile haulage vehicles and/or maintenance/supervisory vehicles or personnel. Such a system may substantially improve the haulage efficiency of largely horizontally distributed mines with multiple muck handling operations. (This application was common to most of the mines visited.) For example, communication can be established between product and mining levels, in most of the visited mines without requiring any additional wiring.

MF transmission is advantageous since it couples onto, follows and is radiated from existing mine wiring. It can be viewed in its simplest form as a higher frequency extension of carrier phone capability. The carrier phone equipment cannot directly operate on an inductively coupled basis because the lower frequency carrier phone signals suffer substantial coupling losses unless the antennas and conductors are very close. Further, most carrier phone transceivers have insufficient sensitivity to operate effectively in wireless applications. In certain instances, dedicated wire added to and simply interfaced with existing mine wiring can extend the signal propagation into remote mine areas or between mine power grids and ensure total mine-wide communications. Such wiring can consist of any common mine wire (such as pager phone or AC power wire and does not need to be a special cable. In the few mines experiencing high attenuation (the haulage level at AMAX being an example) the dedicated wiring can be configured as an MF leaky feeder.

A base station can be inductively or directly coupled to existing mine wiring at a single location. Short lengths of dedicated wire can be used to reduce transmit coupling losses when direct feeding is not feasible. The inductive coupling of a fixed-located transmitter results in a 25-30 dB reduction in coupled current. This is not detrimental in many cases, because the mines are small enough and attenuation is low enough that mine-wide communication is still directly possible. For large or greatly attenuated mines, reducing this loss through special treatment of the fixed-located radio may be advantageous and may minimize the requirements for a repeater. However, repeaters are expected to be required for mine-wide coverage of some mines.

The greatest advantage of wireless MF communication is the ability to communicate between any locations in the mine (near existing wiring) without being restricted to fixed locations such as phones. Communication with vehicles or personnel in motion is also possible and has potential desirability for some mines. In one mine (Con-Sil), communication with a cage in motion in a shaft was demonstrated.

1.3 AREAS FOR FURTHER WORK

The data base accrued during this program supports the applicability of MF wireless equipment for the communication needs of metal/non-metal mining operations. The results from this program augment the preceding 6-7 years of testing in coal mines to establish an overwhelming level of confidence in the capabilities and usefulness of medium-frequency wireless communications in all underground mines.

Areas for future work should focus on the results obtained from configuring and installing the first of several practical system embodiments with regard to the technical details of selecting optimum frequencies, repeater requirements and special line treatments. These activities will provide "levels of refinement" only and are not directly related to specific aspects of operational feasibility.

More importantly, the economic benefits of improving productivity and the health and safety in mining operations due to improved wireless communications needs to be evaluated to provide a cost-basis incentive for mines to make use of the new communication equipment which is becoming available.

Finally, the Bureau should act immediately to standardize wireless mine equipment operational specifications (similar to the standards for pager phones) to encourage the compatibility of system components from the multiple communication equipment supply sources that will appear as the mine MF communication market develops.

2.0 INTRODUCTION

This report presents the results of wide-frequency wireless radio propagation measurements performed under U.S. Bureau of Mines Contract J0308012, "Propagation of EM Signals in Underground Metal/Non-Metal Mines". This work, performed over a nominal 9-month period from September 1980 through May 1981, has entailed the characterization of wireless radio transmission in six metal/non-metal mines. This characterization was performed over a continuous frequency range from 0.2 - 1000 MHz supplemented with limited testing at a spot frequency of 10 GHz.

2.1 BACKGROUND - STATEMENT OF THE PROBLEM

The research reported herein is an extension of previously performed wireless radio characterization studies in coal mines by Terry S. Cory, P.E. under two previous Contracts H0366028, "Propagation of EM Signals in Underground Mines", and H0377053, "Electromagnetic Propagation in Low Coal Mines at Medium Frequencies". These previous studies were limited in frequency range to 0.1 - 4 MHz using continuous wave (CW) instrumentation. The current work has employed modern swept-frequency techniques in addition to CW testing, thus enabling more efficient and comprehensive characterization of mines.

The previous work, beginning in 1974-1975, was performed in conjunction with a U.S.B.M. sponsored prototype radio development by Rockwell/Collins under Contract H0346067 and a companion analytical study by Arthur D. Little under U.S.B.M. Contract H0346045. The previous work established the feasibility of local coal seam transmission at medium frequencies at ranges to 1600 feet in conductor-free areas and long range transmission via inductive coupling into existing mine wiring up to four miles.

Within the last two years, the mine supply industry has become interested in extending carrier phone communication capabilities to vehicles and personnel on a wireless basis, and in providing equivalent carrier phone communications in mines without DC haulage. The current work is very timely as it roughly coincides with the first introduction of mature wireless communications hardware to the marketplace by the Mine Safety Appliance Company. This introduction has been greatly aided and expedited by the U.S.B.M. development sponsorship of a modern set of medium frequency wireless radio system elements by A.R.F. Products Co. under Contract H0308004.

The potential of improving the health, safety and operational efficiency in coal mining operations through wireless communications with roving vehicles and personnel has long been recognized by the

Bureau. But the efficacy of wireless communications in metal/non-metal mines in terms of either technical feasibility or operational significance has not been shown to the mine electronics community. This is because the wide variations in mining techniques, topologies and geological parameters which exist in these metal/non-metal mines have precluded the tacit extension of the previous work. Thus, a goal of this current work has been to attain an understanding of the varied operations in these mines and to seek out common needs and possibilities for improved communications.

A compendium of wireless communication system design information has previously been prepared by the authors under U.S.B.M. Contracts J0395072 and H0377013, "Wireless Communications for Trackless Haulage Vehicles". This work compiled the results of the foregoing referenced wireless work with all other pertinent work known by the authors at that time, circa 1979. This compendium provides the data base for the current program. Although an updating of this rather comprehensive compendium is beyond the scope of this contract, the current results compliment the compended data and extend its general applicability.

To date, neither large scale developmental or operational wireless systems exist in mines, except for a few instances where carrier phone operation has been extended to moving vehicles through the use of inductive vehicular antennas. Generally, the relatively poor sensitivity of carrier phone systems has precluded their proliferation in this application. UHF systems employing reflectors and repeaters have also been adapted to mines on a limited basis however their utility is largely limited to line of sight applications (such as along haulageways) and complete mine-wide coverage is untenably expensive for most mines (as evidenced by the limited number of operational systems in spite of the technological feasibility and product availability which now spans a decade).

Wireless medium frequency technology is now at the threshold of operational realization and a proliferation of wireless implementations is expected to occur in the mining industry over the next few years. The authors hope that this work will provide a significant contribution to this growth in wireless mine communications.

This report has been written as a practical document which may be used on an industry-wide basis by qualified system applications people in addition to scientific researchers. It is not a "stand-alone" document, however, and the design of complete systems is additionally referenced to reports from the foregoing contracts.

2.2 METAL/NON-METAL MINING OPERATIONS SUMMARY

Mines were selected (from information found in the 1980 E&MJ

INTERNATIONAL DIRECTORY OF MINING AND MINERAL PROCESSING OPERATIONS
and from 1980 MSHA computer printouts provided by the MSHA Health and Safety Analysis Center in Denver, Colorado) according to general criteria including the following:

- significance of the product being mined
- size of the mine & number of employees
- type of ore, metal or non-metal
- type of ore deposit
- type of mining technique

Mines considered as viable candidates for this program were comprised of non-metal/non-rock mines (of which there are 105 total) with 100 employees or more (of which there are 26); and metal mines (more than 800) with 100 employees or more (of which there are 73). Statistics on the non-metal/non-rock mines include:

- | | |
|------------------------------|-----|
| - total mines | 105 |
| - fewer than 25 employees | 63 |
| - w/25-50 employees | 6 |
| - w/50-100 employees | 10 |
| - w/100-200 employees | 9 |
| - w/200-400 employees | 13 |
| - greater than 400 employees | 5 |
- 60% have fewer than 25 employees
 - 15% have 25-100 employees
 - 25% have greater than 100 employees

Similar statistics for metal mines were not assessed for fewer than 100 employees due to the large number of mines involved. However, for both non-metal/non-rock and metal mines, most are very small and there are only about 100 mines total in both categories with 100 employees or more.

By ore type for metal mines, the top four in descending order of importance by number of employees are:

- copper
- uranium
- lead/zinc
- molybdenum,

and by the number of mines are:

- lead/zinc
- uranium
- copper
- silver.

There are only three molybdenum mines in the U.S. and there probably will not be more in the near future, so these mines were ruled out as being of primary importance for the purposes of this study. Copper, uranium and lead/zinc were left as the top three based on the number of employees, the number of mines and their continuing strategic and economic importance.

Precious metal mines are not necessarily rankable in importance by mine size or number of employees because of the economic value of their product. A silver mine in the Cour d'Alene mining district, was added to the top three metals in lieu of other types of precious metal mines (measurements are also required there by the contract). Additionally, metal mines are probably of more economic importance than are non-metal mines. Four out of the six mines available for selection were chosen to be metal mines.

By ore/product type for non-metal/non-rock mines, the top four in descending order both by number of mines and number of employees are:

- salt
- potash (potassium oxide)
- sodium
- oil shale.

A potash mine was selected for testing because:

- the mining operations and topologies are more like coal mines than for any other ore type
- the overburden and underburden are salt; thus, constitutively, a potash mine is a salt mine except for topological details. Further, due to the extent of the salt layers, the strata presents a nearly homogenous (nearly theoretically ideal) medium for testing propagation.

An oil shale mine was selected for testing in lieu of sodium because of the anticipated economic importance and the expected rapid

proliferation of these mines in the near future.

The top five states in terms of number of mines of both metal and non-metal/non-rock ores are:

- New Mexico
- Missouri
- Colorado
- Tennessee
- Idaho.

Five of the six selected mines were located in the above list and the sixth mine in Arizona.

The mine types selected for testing during this program, in order of visitation, were as follows:

- Oil Shale (Western Colorado)
thick bedded deposit; multi-level
in-situ retort
- Uranium (Northwestern New Mexico)
bedded deposit in sandstone;
irregular room & pillar in stopes
varying with grade of ore
- Potash (Southern New Mexico)
bedded deposit in massive salt
deposit
- Lead/Zinc (Eastern Missouri)
bedded deposit
- Copper (Southern Arizona)
massive deposit; block caving
used
- Silver (Northern Idaho)
deep-vein metal

The following subsections summarize the operations and other salient characteristics of the visited mines.

2.2.1 OCCIDENTAL OIL SHALE, INC. LOGAN WASH MINE

Occidental Oil Shale, Inc., in cooperation with the Department of Energy, has developed an "in-situ" process for the extraction of crude oil from oil shale in their experimental Logan Wash mine outside of Grand Junction, Colorado. Oil shale is fragmented and heated in massive crucibles (called retorts) to vaporize the entrapped oil, which is then condensed, collected and refined. The new process consists of the fabrication of retorts underground from the strata surrounding the ore to be processed. The retorts are ignited and result in a gasification of the oil with subsequent condensation and flow of oil from the retort base. The operation at Logans Wash involves development of three levels which are located at the top, middle and base of the retorts, with approximately 100 feet of separation between levels. Future operations may permit elimination of the middle level. The retorts are configured in rows along drifts that are twenty to thirty feet wide and ten to twenty feet in height. The drifts are connected by perpendicular crosscuts at regular intervals so that the mine topology has the appearance of a dense matrix of retorts, which share common oil pumping and off-gas lines. The technology developed at Logan Wash will be applied in a production facility at Occidental Oil Shale's Cathedral Bluff facility, which is being designed at this time and is expected to become operational in the mid 1980's.

Oil shale is stratified, massively disseminated rock, which is normally bounded by other grades of shale. Typical strata may extend from several feet to several thousand feet in depth. Due to the vast deposits of oil shale in Colorado, Utah, and Wyoming (and the obvious economic factors), the largest and most homogeneous deposits will be initially mined. The mine development consists of sinking vertical shafts and driving drifts with conventional mining equipment. Trackless haulage vehicles are used to remove the excess shale, which is transported to conventional surface retorting operations. The proposed development at Cathedral Bluff will use a combination of belt and trackless haulage conveyance systems. The drifts are supported by roof bolts and wire mesh. The mining operation results in the release of methane gas, so that that monitoring and ventilation systems similar to those used in coal mines are required, when "high-density" ore is being mined. The consistent use of explosives and the gassy environment necessitate the use of intrinsically safe communication equipment for both vehicular and man-carried equipment.

A retort is fabricated by sinking a shaft and placing rings of explosives along the shaft height to systematically rubblize the interior rock. The intact rock around the retort then acts as the

retort casing. The retort is sealed, pressure tested, and the top surface of the fragmented rock is ignited. Steam and air are injected to heat the retort to 900-1000 degrees F. The heat and pressure cause gasification of the oil near the flame front, which then diffuses downward, condenses, and flows out of a pipe at the retort base. Initially, an oil/water slurry drains from the base which is collected and separated. In addition to the fluid mixture, a substantial amount of exhaust gas ("off-gas") is generated by the retort, which contains the characteristic products of raw hydro-carbon combustion (CO, CO₂, H₂S and some uncombusted hydrocarbons). The off-gas is piped to a surface processing plant which scrubs and neutralizes the gas before venting it to the atmosphere. The flame front is sustained by gasified oil and blown-in air and slowly progresses downward in the retort. The retort actively produces oil for approximately nine months and then slowly burns out over a period of another year.

The oil production consists of two discrete phases which have separate communication requirements. The mining and fabrication of the retorts is the first phase and had operational communication requirements similar to multi-level, multi-working section coal mining operations. Communication links are required to hoists, within working sections (between all three levels), along haulageways and conveyor belts, and to the surface support plants: mine support (ventilation, dewatering, haulage); surface processing (surface shale transport operations); and utilities (electricity, water, fuel). The mining phase requires ventilation monitoring for LEL methane (the lowest explosive level at which methane/air mixtures will ignite) and air flow.

The second operational phase is the process control phase which is conducted by a separate group of technical personnel. The process control group coordinates the plumbing, sealing, firing and monitoring operations associated with the oil extraction process. Process control activities include tracking the fire front in the retorts (and redirecting it if necessary), evaluating the off-gas composition (as an indication of retort performance), evaluating the air purification process and monitoring the gas and fluid lines for leakage. Communication links are required locally at the retorts (between the levels and along the drifts) and to the surface plants, including the off-gas processing plant. Monitoring is required at regular intervals along the off-gas lines and to track the flame front in the retorts.

The fully operational system at Cathedral Bluff will contain ninety-six producing retorts, with equivalent numbers in fabrication and "cooling-down". Substantial separation between mining and producing areas will be maintained to preserve the integrity of the active retort structures from the stress of blasting and the drift and shaft mining operations.

The Logan Wash mine has been used to develop the production techniques and procedures for fabricating and operating the in-situ retorting system. The facility operates on three active levels underground and on the surface of a mesa which is approximately 2,500 feet above the local terrain. The propagation tests were conducted on the lowest or "product" level at the end of the L-700 drift near Retort #6. The rock along the drift was observed to be a stratified deposit of common and oil shale of varying composition.

2.2.2 UNITED NUCLEAR/HOMESTAKE PARTNERS SECTION 23 MINE

The United Nuclear/Homestake Partners uranium mines are located in the Ambrosia Lake district of Northwestern New Mexico. This district, together with contiguous areas in this part of New Mexico, contains approximately 50% of the known uranium deposits in the world. Mining in this overall region has been in progress for between 20 and 30 years.

Two distinctive types of ore bodies are encountered in the district, and are referred to as primary (trend) and secondary (redistributed) deposits. These deposits are located approximately 500-800 feet beneath the relatively flat Ambrosia Lake surface.

The primary ore bodies vary from a few inches thick at the edges to typically seven feet at the "roll" near the center, and seldom exceed 17 feet. The primary ore is a dark grey-to-black medium grained sandstone. The typical ore body lateral extent is approximately 200 feet, but they occasionally reach as much as 1000 feet in length. The secondary ore bodies are larger and range in thickness between seven and 150 feet.

The object of uranium mining is to take the ore with as little waste as possible. Once a particular body is located and mining begins, an effort is made to minimize the size of stope cross sections for the thin ores. The principal mining technique is the stope and raise method. Because of the discrete and physically variable nature of the ore bodies, a number of variations of the mining technique are often employed within a single mine. Normally within a local area two levels are employed, however, the depth of these levels will vary within the overall mine topology and the composite mine will likely embody a number of slightly offset levels. The stope areas are relatively small and are somewhat random, depending on what must be done to get the ore. In the rare cases where the ore bodies are thicker than the usual stope height of seven feet, a "mini" block caving ("scram") method is used by constructing several short raises within the stopes and pulling the ore until the upper ore body limit is reached. For larger ore bodies of relatively uniform lateral extent, the stope areas employ a limited room-and-pillar geometry with pillars

on about 30 foot centers.

The most common means of mining the smaller ore bodies employs slushers to "pull" the dynamited ore to a single muck pocket raise. The slusher is a small drag line with a winch on the head or drum end (operable from 480 VAC) with a pulley on the tail end. The pillars are eventually pulled with temporary timber support being provided.

In developing an ore body, drifts are driven (30-50feet) beneath the deposit. Access and muck pocket raises are then extended vertically into the body, with subsequent horizontal stope development. Ore body probing, surveying and detailing are performed every shift to provide effective production control of the mining.

Historically, the haulage was 100% tracked using diesel motors and a string of 8-ton (5-yard) cars. This permitted the use of the narrowest haulage drifts (typically seven feet high and 10-feet wide). Currently, the haulage is a mixture of tracked and rubber tired (using diesel articulated dump trucks); although, the final haulage to the main portal shaft muck and waste pockets for skipping is tracked. The rubber tired haulage developed as a consequence of the second major variation in mining technique, called "Wagner*" mining. The name of this type is based on use of a brand name (Wagner*) small loader that is used in lieu of slushers for loading the ore for transport to the muck pocket raise grizzlies. Wagner* mining offers great flexibility in developing haulage topologies in the mine, but requires larger drifts for the trucks and larger stopes for the loaders. Hence, more potential waste per ton of ore mined.

To illustrate the varied topology and haulage procedures involved, a small ore body may use a slusher to develop the stopes and fill the stope muck pocket. These pockets may be pulled either by a truck or a train. If the muck is pulled by a truck motorman, the muck is then hauled and dumped into another muck pocket for loading onto a train; which, in turn, hauls the muck (and/or waste) to the primary muck pocket at the main portal shaft for skipping to the surface.

* Reference to specific brands, equipment, or trade names in this report is made to facilitate understanding and does not imply endorsement by the Bureau of Mines.

The uranium oxide, U_3O_8 , constituency of primary ore runs 10% or better. Dilution of the ore in the mined material occurs because the ore cross section per drift/stope is frequently smaller than the total cross section size required for the mine vehicles and equipment. The concentration per volume of material mined in the primary trend is roughly 0.3-0.4%, which at \$30 per pound (1981 value provided by mine personnel) has a net value of \$180-\$240 per ton. The secondary ore is approximately 0.4% uranium oxide, but does not suffer as severe a dilution in volume of material mined because the larger ore deposits are more congruent with the standard drift/stope cross sections. The concentration per volume of material mined in a secondary ore body may average 0.15-0.2%, yielding \$90-\$120 per ton at current (1981) values of \$30 per pound of "yellow cake".

Contract rate determination is an important aspect of uranium mining management in this area. Typical tonnage output of section mines runs 500 to 1000 tons per day. The actual mining in the stopes is performed by two-man crews working on a contract basis. A very active mine will employ up to 20 crews per shift. The crews are reimbursed on a percentage basis of production which exceeds a predetermined "break even" level, in addition to a base wage. The IE process in these mines includes in-situ sampling of the ore. Samples are taken each shift to determine specifically how the stope development in each mined area should proceed during the following shift. The shifter on each level has the considerable responsibility of overseeing the planning details of mining each day on each level. The close and continuous inspection of the mine development by the mine management and the use of industrial engineering provides visibility to mine management which compensates in some respects for the limitations of the dilutely implemented communication system currently used in the mine.

2.2.3 KERR-MCGEE CHEMICAL CORP. HOBBS POTASH FACILITY MINE

The Kerr-McGee Hobbs Potash Facility is one of seven separately operated potash mines located along a thirty mile section of Route 82 between Carlsbad and Hobbs, New Mexico. These mines employ approximately three thousand persons and produce 97% of the potash mined in the United States with a daily production of 56,000 tons of ore. (Canada is the world's leading producer with a production of 99,000 tons per day.) Six of the mines (including the Kerr-McGee mine) operate on one level, while one mine, the Amax Chemical Corporation mine, operates on four levels. The potash ore is typically a bedded sedimentary deposit nominally ranging in depth from two to eight feet and bordered by "salt" (sodium chloride) deposits which are hundreds of feet in depth. "High-grade" ore is a transparent crystalline solid characterized by a blue isotope which is randomly diffused through the ore body. Typical ore has a 15 to 30% yield and is observed to be rust-colored, flecked with transparent salt and translucent potash

crystals. The potash ore has an extremely bitter taste, which is readily distinguished from the bordering salt deposits. Generally the potash ore is separated from the salt bodies by a thin (nominally one inch) layer of gray "mud", which permits simple visual differentiation of the salt and ore bodies.

The crystalline structure of the ore and surrounding over-burden results in limited stress on the "back" (roof), floor and walls, so that roof falls are rare and the "rock-burst" phenomenon of hard-rock mines is non-existent. Old sections of the mine are observed to show bulging and sheet cleavage of the room walls. The strata is homogenous except for small random pockets of gas or water which are opened during the mining process. Generally these pockets are regarded as more of a nuisance than a hazard, although MSHA is currently (1981) conducting gas sample analysis to determine if combustible gases are present. Roof bolts and/or guniting is used in permanent underground facilities, such as near lifts, power stations, inventory and maintenance areas and sporadically along haulage and intake air rooms where pocketed areas have been uncovered or potential roof cleavage is suspected. Timbers and headers are not required.

The mining process closely parallels that of coal mining with continuous miners or long-wall miners and belt haulage used throughout the basin. The mining installations include surface processing plants, which refine and bag the processed potash. Surface inventory storage facilities stock the refined product until it is shipped by rail or by trucks.

The Kerr-McGee Hobbs Potash Facility is located in the number 10 bore region of the Carlsbad basin approximately thirty miles due East of Carlsbad, New Mexico. The facility has 350 employees and operates eight working sections in each of three shifts and produces about nine thousand tons of ore per day.

The mining operation is approximately 1800 feet in depth and is conducted on one level over an area 6.25 X 5.1 miles. The mine has two separate centrally located lifts for muck and men/equipment respectively. The North/Northwest section of the mine has been mined out and abandoned. Current and future mine development is proceeding Southwest and Northeast of the lifts. The major mine development is expected to occur East of the lifts. The mine operates six continuous miners with belt haulage from the faces to the production lift. Men and equipment are transported with electric "scooters" (built and maintained by the mine) and diesel trackless vehicles.

The mine advancement consists of three parallel entries: the intake air entry (also normally used for vehicular transportation of men and materials and occasionally used for routing power cables); the belt

entry (also normally used for cable distribution), and; the return air entry. The entries are uniformly 25 feet wide (the width of two continuous miner cuts) and 58" tall. (The mining seams are also usually 58" tall, although some intake entries are cut to be six feet tall, if they are expected to be used for transportation for several years.) The entries are spaced at 120' centers and are linked by (60) diagonal drifts ("breakthroughs", designated by "BT" on the mine maps) at 160' intervals. The breakthroughs are sequentially numbered along straight slopes and permit rapid identifiers for locating positions in the mine. The mine is also divided into "areas" which developed chronologically and were sequentially numbered as they were developed, so that contiguous areas do not necessarily have sequential designators. The areas are marked on the mine maps. As the mine advances, the breakthroughs between the belt and exhaust rooms are sealed to provide positive ventilation along the belt and up into the working sections.

Secondary sets of three parallel entries are driven perpendicular to the main entries to support the punch mining operation of the continuous miners. The mining process is estimated to extract approximately 84% of the available ore body. The stability of the crystalline rock results in clean cuts by the continuous miners when the rooms are formed, so that the floor, "back" and walls of the rooms are flat surfaces meeting in defined corners. The ore body slopes at approximately a 3% grade from West to East, so the three parallel main entries are gently sloping long straight drifts, with slightly undulating floors, but uniform topology and with numerous periodic crosscuts.

The continuous miners feed ore onto the conveyor belts which have belt power and transfer stations every 1500 to 2500 feet up to the production lift. The ore is transported to the muck lift which transports it to the surface. The men/equipment lift (called the supply lift) is within several hundred feet of the production lift and both lifts are controlled by a single hoistman. Ore is processed by a hot dissolution operation called "leaching" followed by fractional crystallization, which separates the potash from the salt and other contaminants.

2.2.4 AMAX LEAD CO. OF MISSOURI BUICK MINE

The Buick mine is the largest single operation along the Viburnum trend in the St. Francis mountains in eastern Missouri. This largely North/South 40-mile long trend is in what once was a barrier reef. The ore body is located 500-1300 feet beneath the surface and is of the massive disseminated fill-in layer type. It is nominally 300-400 feet wide and 13-16 feet thick, but exceeds 100 foot thickness in places. The Buick mine working level depth is 1200 feet. The mineralization

consists largely of galena (lead sulfide; 80% lead and 20% sulphur) and sphalerite (zinc sulfide; 67% zinc and 33% sulphur) with grades of 6-8% (lead) and 2-3% (zinc) per unit weight of product. The Buick operation, an AMAX/Homestake partnership, has a nominal daily muck product output of 7000 tons, resulting principally in 130,000 to 140,000 tons of refined lead per year, 56,000 tons of sulphuric acid, and a nominal amount of refined concentrate and silver.

Lead/zinc mining in the area consists mostly of room-and-pillar mining with rubber-tired haulage to the central muck raise which feeds the crusher. The mine topology follows the lenticular ore bodies and, thus, mines are long and slender; typically several miles in extent. Typical dimensions are 35 feet wide by 13-16 feet high drifts with pillars on 60-foot centers. Due to the size of the Buick mine, the rubber tired haulage is supplemented with tracked haulage in a drift approximately 90 feet below the working level. In the haulage drift at Buick, the drift width is roughly 20-24 feet.

The Buick mine is approximately four miles long and is divided into "North mine" and "South mine" legs with access shafts and service areas near the center. Mining operations are primarily at the mine ends with a little "clean up" mining at other locations. This mine is eight years old with a useful remaining life in excess of 30 years.

The ore is mined in a balanced manner, with an attempt made to keep the ore grade nearly constant and not to mine just the richest ore first. On either side of the mine, ventilation shafts are located about a mile from the mine center. The air is pulled in at the mine center, where it is split and routed to the faces and then pulled out the ventilation shafts. The mine backbone power is 4160 VAC supplied in 3 grids and stepped down to a working voltage of 480 VAC. All mine wiring is run along the lower tracked haulage drifts and is elevated to the working product level adjacent to the ore passes (muck raises between levels). Going North, the AC power cables are bundled together and run on the back either along the left-hand rib or near the back center. Pager phones are generally located at each ore pass and at other key locations along the haulage level. The phone lines are also elevated to the product level near the ore passes. The phone line (a shielded twisted pair) is generally run along the center of the back. Air lines and water pipe in this area are bundled together and are run along the right-hand rib near the back. The back is sound, unbolted, and without mesh on the haulage level. Along the north mine leg, the haulage level gradually approaches the ore body on a 1-2% grade beyond the Northeast/Northwest haulage "Y".

On the product level, the pillars remain integral and no retreat "pillar pulling" has begun. This activity will probably not be started for another 6-7 years.

2.2.5 MAGMA COPPER CO. SAN MANUEL MINE

The San Manuel mine is the largest copper mine in the U.S., efficiently extracting copper and molybdenum sulfide from the low-grade San Manuel ore body. The San Manuel mine operation employs in excess of 1000 men/shift with gross ore production between 60,000 and 70,000 tons per day. The mining operation employs the block caving technique which is actively implemented on three levels (2075, 2375, 2675 feet for haulage and 2015, 2315, 2615 product/grizzly levels). The ore haulage is largely via D.C. trolley trains to four (3A, 3B, 3C, 3D) product shafts for skipping to the surface. An additional three shafts at two locations are used to convey men, materials, and developmental rock extractions into and out of the mine. On each haulage level, the trains carry ore an average of two miles one-way from the ore raises to the dump points.

All haulage drift segments contain the D.C. trolley wire located just off the back center with the ground return wire bus also running with the "hot" trolley wire and separated by about 10 inches. The ground wire branches to the track at periodic intervals of several hundred feet. Track construction/condition is excellent with a well-laid bed of wooden ties in ballast. Particular attention is paid to track electrical bonding; which, on the long haulage runs, is very good (electrical bonding near the grizzly ore chutes load points is poorer). Also located in the typical haulage drift is the audio pager phone line (generally in one of the back/rib corners), a 2400 VAC power cable and the usual air-line/water-line large pipe bundle. The ribs and back did not have metallic mesh covering. In the timbered drifts, the timbers were on both the ribs and the back spaced longitudinally on about 5-foot centers.

2.2.6 HECLA MINING CO. CON-SIL MINE

The Con-Sil is a recently re-opened mine, sponsored by a consortium of mining companies in the Silver Valley with Hecla as the operating company. This relatively small mine, located adjacent to the Sunshine and Silver Dollar mines, delivers in excess of 100 tons/day to a small mill conveniently located near the Silver Summit portal.

Typical of operations in the Valley, the mining occurs below the 3000 foot level employing the "stope and raise with sand backfill method" along drifts running laterally away from the primary shaft stations at nominally vertically spaced 200 foot levels. The Con-Sil is presently pulling muck from the 4000-level via the main Silver Summit shaft. The intermediate Winze shaft between the 3000 and 4000-levels, that will permit mining on intervening levels, is being repaired following damage sustained during an approximate three year shutdown of this

mine. The muck haulage occurs via battery operated trains on the lower haulage levels to muck pockets adjoining the main shaft. It continues via D.C. trolley-operated trains from the top station through the one mile portal drift to the mill dump point several hundred feet from the portal.

The typical haulage drift in the Con-Sil has cross-sectional dimensions of about seven-foot head clearance from the floor-to-back and about six-foot width between ribs. The narrow gauge track (18 inches center-center with about 40 pound rail) is centered in the drift and well bedded. The water return ditch is also along the left-hand side facing the inby direction. The portal drift contains both a single cable bundle suspended from a messenger cable and the D.C. trolley bus. The operating level drifts, looking in the inby direction, contain an air line and water line bundle along and roughly vertically centered on the left rib above the return ditch. The cable bundle containing the 2400 and 440 VAC lines and the phone line is to the left-center of the back immediately below a pair of openwire 110 VAC lighting lines, and a sand line along the right rib suspended about one foot from the back. The back is generally bare, unmeshed, and unbolted.

2.3 DEFINITION OF COMMUNICATIONS REQUIREMENTS

With the exception of deep vein mines, which have logistic transport problems, and oil shale mines, which have massive ongoing operation coordination problems, the primary need for communications in metal/non-metal mines is associated with improving haulage operations. There is no belt haulage in these mines (except for the potash mine) and no dedicated haulage from each section all the way to the main dump point. Many of these mines have separate haulage and product vertical levels. Haulage communication needs are readily recognized by mine management.

There is no hierarchy of phones in these mines as there are in coal mines, with the deployment of phones being dilute and with no standard requirement for a phone being located within a specific minimum distance from a working stope/face/etc.. Currently, there is generally no means to communicate from a central location to individual mining crews. Communications to such crews are not considered essential by many mines. Metal/non-metal mines share with coal mines the common need to locate key (and roving) supervisory or maintenance personnel.

The following subsections present a summary of communication requirements for each visited mine identifying aspects where wireless communications could be instrumental in satisfying these requirements.

2.3.1 OCCIDENTAL OIL SHALE LOGAN WASH MINE

Although the Logan Wash mine is a horizontal entry "punch" mine, the practical operational facility at Cathedral Bluffs will entail a vertical entry shaft. In the initial mining operation before construction of the first retorts, wireless communications could be used in the shaft and along the developing drifts to coordinate these mining operations.

Operationally, communications are required as part of both the mining and the process control functions. During retort construction, multi-level communications could greatly facilitate the mining and rubblization operations. Once the retorts have been fired, the communications requirements mainly fall in the area of monitoring transmission linkages for observation of sensors. This communications requirement will be very dense for the active retorts in monitoring temperature and off-gas conditions.

2.3.2 UNITED NUCLEAR/HOMESTAKE PARTNERS SECTION 23 MINE

The ore in muck pocket raises is pulled by motormen operating either the rubber tired dump trucks or the trains with ore cars. Currently there is no systematic means to tell the motormen that a particular raise is full and should be pulled. As a consequence, the operation of ore handling can become "muck-bound", where haulage (and even mining) must cease until the muck pockets are pulled and there is again a place to dump the ore.

In the authors' experience, this is the first type mine using tracked haulage where a dispatcher and carrier phones were not used to improve the efficiency of haulage operations. In addition to the muck-pull dispatch, a central dispatcher can provides functions of traffic regulation and in-transit or roving personnel location. A wireless communication system providing the equivalent of carrier phone communications would be immediately beneficial to the mining operation. While there are phones within walking distance of the mining crews in the stopes, the relatively remote access of these phones relative to the ease of communication is not as flexible as it is in coal mines. This is especially true considering the "multi-tiered" haulage process in this type of mine. As part of a centralized wireless system for "on-the-move" communications, an entry into this wireless system from the fixed located stope areas could also prove beneficial.

2.3.3 KERR-MCGEE CHEMICAL CORP. HOBBS POTASH MINE FACILITY

The Hobbs Potash Facility mine has an operational mine pager phone system, which provides the primary communication link in the mine. Phones are located at working sections, belt stations, shops and

office areas. The mine management estimates that this system provides approximately 20% coverage of the mine area. However, while the electric scooters provide rapid mobile transportation for key personnel, they also make location of those people very difficult. Communication with trackless vehicles is therefore, the most significant problem in the mine. For several years the mine successfully used mine carrier phones, operating at 88KHZ with 20 watts of power into loop antennas, for wireless communication to the trackless vehicles. (The performance of the system was augmented by the routing of a dedicated wire along the "pinch wires" on the belt system, so that signals could be coupled onto the dedicated wire and pinch wire pair.) However, difficulties in maintaining the system led to its abandonment. The mine currently uses commercial VHF "walkie-talkies" for communication up the production shaft and has purchased 61KHZ carrier phones adapted with couplers for communication from the hoist cages to the surface during maintenance operations.

In general, the mine management indicated that as the mine expands further from the shafts, the communications problems will increase, and the desirability of having an operational wireless communication system capable of communicating with trackless vehicles will also increase. The management indicated that approximately fifty vehicles would be served by such a system and that the system would be economically feasible if the transceiver cost did not exceed \$1500. By contrast, the mine investigated a UHF "leaky feeder" system which was estimated to require \$200,000 in cable plant alone. Presently, the mine may be characterized as recognizing a need and willing to install a wireless communication system, if the product were economically available.

The operational requirements for such a system consist of the units having self-contained power and being able to communicate from any of the primary rooms to the office areas near the shafts. The system is not limited by transmit power, but is limited by cost as indicated above. With the present power distribution plant, the transceiver will always be located within one room of a power cable as long as it is in one of the main rooms normally used for vehicular transportation. The mine has also indicated that dedicated lines to augment the existing conductors could be inexpensively added to the existing cable plant by using "ramset" mounting of cable to the room "back" or walls (two men can run several miles of light wire per day using this technique).

2.3.4 AMAX LEAD CO. OF MISSOURI BUICK MINE

Existing communications at Buick are dilute and consist only of pager phones. This was sufficient when the mine was small and travel to the face areas was not time consuming. But, there is currently no means to communicate with vehicular traffic or with roving maintenance or

supervisory personnel. The mine now is growing rapidly which is increasing the North/South range required to go from the faces to the central portal area. Mine-wide communications are desirable to facilitate operations in the following ways:

- 1) use of a "dispatcher" to regulate the timing of haulage traffic to the crusher
- 2) vehicular communications between rubber-tired trucks on the product level and trains on the haulage level to convey that particular ore passes are full and should be pulled (perhaps via a dispatcher or a shifter)
- 3) location of key maintenance or supervisory personnel (perhaps via a dispatcher)
- 4) quick notification of any haulage or maintenance problems occurring or observed enroute where pager phones are not available.

The mine wide "area coverage" communication needs can only be served efficiently by a wireless system. At a minimum, this system will require a radio and an antenna for each haulage vehicle plus a "fixed" station at a central "dispatch" location in the mine. The transmission media for this system must consist of existing mine wiring and/or dedicated wiring to serve as a path for coupled "carrier current" from the radio antennas. This type of communication, appropriate for Buick, will be summarized in the next section together with implementation possibilities.

2.3.5 MAGMA COPPER COMPANY SAN MANUEL MINE

The existing communications emanate from a dispatch location on each level and consist of both pager phone and carrier phone service. A separate carrier phone frequency is used on each production level: 115 KHz on the upper level; 145 KHz on the middle level; and 190 KHz on the new lower level. There is currently a substantial amount of signal cross coupling between the levels. The typical MF spectrum contains a raster of harmonics and rectified/mixed cross products of these fundamentals and harmonics.

Audio and radio communications on the grizzly level are currently limited to locations near certain ore passes and are dilute.

With this as a basis, several communication-related requirements exist. These include:

- improving the conventional carrier phone mode of communications to provide improved performance near the extremities of each haulage level

- wireless communications on the haulage level to serve battery-operated service vehicles and small locomotives so that "stingers" (which require vehicle stopping) are not needed in order to reach the dispatcher

- wireless communications on the grizzly levels to serve battery operated vehicles with an overlay of the existing carrier phone frequencies on these levels to provide haulage coordination and to keep product level operations from becoming muck-bound

- portable communications for maintenance/supervisory personnel tied into either the carrier phone channel or into a separate "command/location" channel to facilitate efficient operation of these personnel and to service special or emergency situations.

2.3.6 HECLA MINING COMPANY CON-SIL MINE

Existing communications consist of single-channel partyline magnetophones at major shaft stations and in the hoistroom. This system is typical of all mines in the valley. No communication is extended beyond the shaft stations and hoistrooms except for a phone at the junction of the 4000-level north crosscut and the 4000-level haulage drift near the Winze shaft location.

With this as a basis, several functional communications possibilities exist for extending the capability of the present system. These include:

- wireless communications between a desired fixed location and roving maintenance or supervisory personnel

The fixed location could be in a shaft hoistroom or on a given operating level shaft station staging area, or in the mine office

communication could be implemented as two-way voice or one-way paging.

- wireless "alarm" communications from a fixed location

into stope areas to alert crews to an impending health or safety problem

- wireless communication between a fixed central location and other fixed locations where crews may be repairing a shaft or to a muck loading location

2.4 OUTLINE OF PERFORMED WORK

The performance of the work consisted of making swept frequency measurements in four bands from 0.2 - 1000 MHz at a fixed distance to select optimum frequencies. The optimum frequencies were examined in detailed CW tests at or near these optimum frequencies with respect to range and coupling parameters for the purpose of characterizing specific details of the transmission modes. This format ensured identification of major propagational effects with expedient convergence to specific investigation of the primary effects. The testing was typically performed in 2 1/2 days at each mine with an additional half-day spent discussing the tests and selecting test sites with the mine management the day before going underground, and a half-day spent reviewing the preliminary test results after the final test day. A typical trip format was as follows:

First Day- - arrive at the mine in early afternoon, review mine maps and select test locations; plan the first day's testing in the evening

Second Day- - perform swept-frequency tests at a fixed range of (1st Day Underground) about 300 feet at MF (0.2-1 MHz), HF (2-20 MHz), VHF (20-200 MHz) and UHF (200-1000 MHz) in one or two locations; test variations included:

antenna vs current probe transmit excitation for MF & HF

antenna orientations/polarizations in the drift and with respect to conductors at MF & HF

Evenings were devoted to selection of optimum frequencies for CW testing.

Third Day- - perform CW tests with test system and/or (2nd Day Underground) prototype MF radios from one or more fixed transmit locations to variable receiving locations

Fourth Day- - complete or repeat any tests from the first two
(3rd Day Underground) days and, if appropriate, perform an X-band
microwave test

IN EVERY MINE, MF INDUCTIVELY COUPLED TRANSMISSION PROVED TO BE THE MOST SIGNIFICANT.

As the program progressed, the authors became more facile in recognizing any unusual phenomena and in arranging the tests to permit their investigation. In large part, the MF/HF tests proved to be tests of particular coupling phenomena to mine wiring. Test parameters in each of the swept ranges began to fall into bounded groups that were consistent from mine-to-mine.

2.5 REPORT CONTENTS

Section 1.0, Executive Summary, is intended as a stand-alone section providing an overview of all the test results and their relationship to practice, scientific knowledge advancement and to technology business development. This section also includes recommendations for further work.

Section 3.0, Technical Approach, presents the characterization of the test system and its relationship to near-optimum hypothetical practical system embodiments. This section also presents a description of the test environments in each individual mine. Tables of test data reduction factors are provided.

Section 4.0, Individual Mine Reduced Test Data, presents the significant reduced data from each individual mine Summary Data Report together with annotations and amplifying comments.

Section 5.0, Presentation of Raw Swept-Frequency Data, presents all the original oscillographs from which the reduced results were derived. Together with data reduction factors given in Section 3.0, the reader can reproduce the reduced results; except as noted.

2.6 DEFINITION OF REPORT TERMS, CONVENTIONS AND NOMENCLATURE

Because this measurement program is closely linked to previous studies sponsored by the Bureau of Mines, the authors have elected to retain elements of the previously adopted nomenclature. In order to alleviate confusion which may arise from a strict technical interpretation of the terms, succinct definitions of several of these terms, reporting conventions and nomenclature follow.

2.6.1 FREQUENCY RANGES

The frequency range from 0.2 MHz to 1000 MHz has been allocated into the following bands which conform to natural limitations of the test equipment used in the field measurements:

Medium Frequency Band The "medium frequency" band encompasses frequencies from 0.2 MHz to 1.0 MHz inclusive. The medium frequency band is designated by the abbreviation "MF" for the sake of brevity in the report text and in the presentation of the data.

High Frequency Band The "high frequency" band encompasses frequencies from 2.0 MHz to 20.0 MHz inclusive. The high frequency band is designated by the abbreviation "HF".

Very High Frequency Band The "very high frequency" band, designated in the report as "VHF", encompasses frequencies from 20.0 MHz to 100 MHz inclusive.

Ultra High Frequency Band The "ultra-high frequency" band, designated in the report as "UHF", encompasses frequencies from 100 MHz to 1000 MHz inclusive.

2.6.2 LOOP ANTENNA ORIENTATIONS

The MF and HF data was accumulated through the use of calibrated loop transmitting and receiving antennas. The antennas exhibit both a physical and an electrical planar geometry, which is used in this program to investigate distinct orthogonal propagational modes. Following are a list of orientation terms and abbreviations adopted for the sake of brevity in the preparation of the text and data of this report.

Coplanar Horizontal Magnetic Dipole The "coplanar horizontal magnetic dipole" antenna orientation consists of aligning an antenna in a vertical plane which intersects the geometric center of the other antenna. When only one antenna is used, such as in exciting adjacent conductors running along a drift, the antenna is aligned in a vertical plane which is parallel with the centerline of the drift. This

orientation is designated as the "Coplanar HMD" orientation in this report.

Axial Horizontal Magnetic Dipole The "axial horizontal magnetic dipole" antenna orientation (designated the "Axial HMD" orientation) consists of aligning an antenna in a vertical plane which is perpendicular to the line which intersects the geometric center of the other antenna. When only one antenna is used, the antenna is aligned in a vertical plane perpendicular to the drift centerline.

Vertical Magnetic Dipole The "vertical magnetic dipole" antenna orientation (designated as the VMD orientation) consists of aligning the antenna in a horizontal plane, which intersects the geometric center of the other antenna, or is related to the height of the drift, if the other antenna is not present.

2.6.3 MONOFILAR EXCITATION

Previous studies in coal mines have resulted in an extensive body of knowledge relating to signal coupling onto and propagating along conductors in those types of mines. Unlike transmission lines, which have characterized parameters that sustain distinctive propagation modes for substantial distances, mine wiring is extremely variable and generally must be characterized empirically. The primary means of characterization which has evolved in the preceding studies, depends on the excitation of individual conductors or conductor ensembles by strong localized magnetic fields. Because the transmission properties of the conductor is unknown, and the return current path may be indeterminate, such excitation has been characterized as "monofilar". The usage of "monofilar" in this context relates only to the excitation of common phase currents in one or more conductors, which does preclude the existence of or mode conversion to differential propagation modes in other conductors. Indeed, with the widely varying topology of conductor types and cable plant configurations, a single mode would not be expected to exist without converting to other modes. "Monofilar" currents, therefore are used to describe currents which are generated in response to a particular excitation phenomena, with indeterminate return currents in other conductors or through the earth.

In some isolated instances, "balanced" parallel conductors are encountered in which equal and opposite currents may be excited, in such symmetrical cases where differential currents are excited, the excitation mode is called "Bifilar". The authors have attempted "Bifilar" excitation of such configurations as trolley power and ground (track) ensembles, but have found that the conductors were too unbalanced to generate significant differential mode currents.

In general, most current excitation appears to be "monofilar", as used in the context of this report, for both localized excitation currents and as the surviving transmission mode of MF signal propagation over long distances.

3.0 TECHNICAL APPROACH

Measurements were conducted in this program using a unique broadband swept-frequency test system. The use of this system permitted a spectral analysis of transmission modes in each mine from MF (0.2 MHz lower limit) through UHF (1000 MHz high limit) from which optimum frequencies were chosen for more detailed measurements/analysis. The test system is described in this section.

Originally, all reduced test data was to have been normalized to sets of near-optimum practical system parameters so that actual system performance could be directly assessed. Following testing in the first mine, the MF and HF data was found to be so closely linked to particular coupling mechanisms that all further reduced data in these ranges was normalized to the test system parameters to facilitate understanding of these mechanisms. The VHF and UHF data continued to be normalized on a practical system basis.

During the course of the program, particular MF/HF coupling phenomena were investigated via measurements and analysis. Additionally, theoretical and practical upper limits on MF/HF transmit performance were determined for practically-sized systems, which are described in this section.

The results obtained in particular mines have been primarily attributed to the physical test environments encountered: electrical parameters of the geological strata, drift topology, drift cross-sectional parameters and details of mine wiring. Individual test system environments of the visited mines are fully described in this section. Significant transmission characteristics found in the individual mines during the swept-frequency tests were examined in detail using conventional continuous wave (CW) field strength meter techniques.

Both swept-frequency and CW test system elements were calibrated prior to the first mine visit. The field strength calibration standard was a Fairchild EMC-25; which was calibrated by the Rockwell/Collins metrology lab test facility in Cedar Rapids prior to the first mine visit.

3.1 TEST SYSTEM CHARACTERIZATION

3.1.1 TEST SYSTEM DESCRIPTIONS

The swept-frequency test system implementations are illustrated in the block diagrams of Figures 4 through 7. The system was generally deployed in a "typical" drift segment with a fixed transmit location and one or more fixed receiving locations at ranges between 150 and 1000 feet; typically, 300-400 feet.

FIGURE 4
 MEDIUM-FREQUENCY (MF) SWEEPED-FREQUENCY TEST
 SYSTEM EQUIPMENT CONFIGURATION

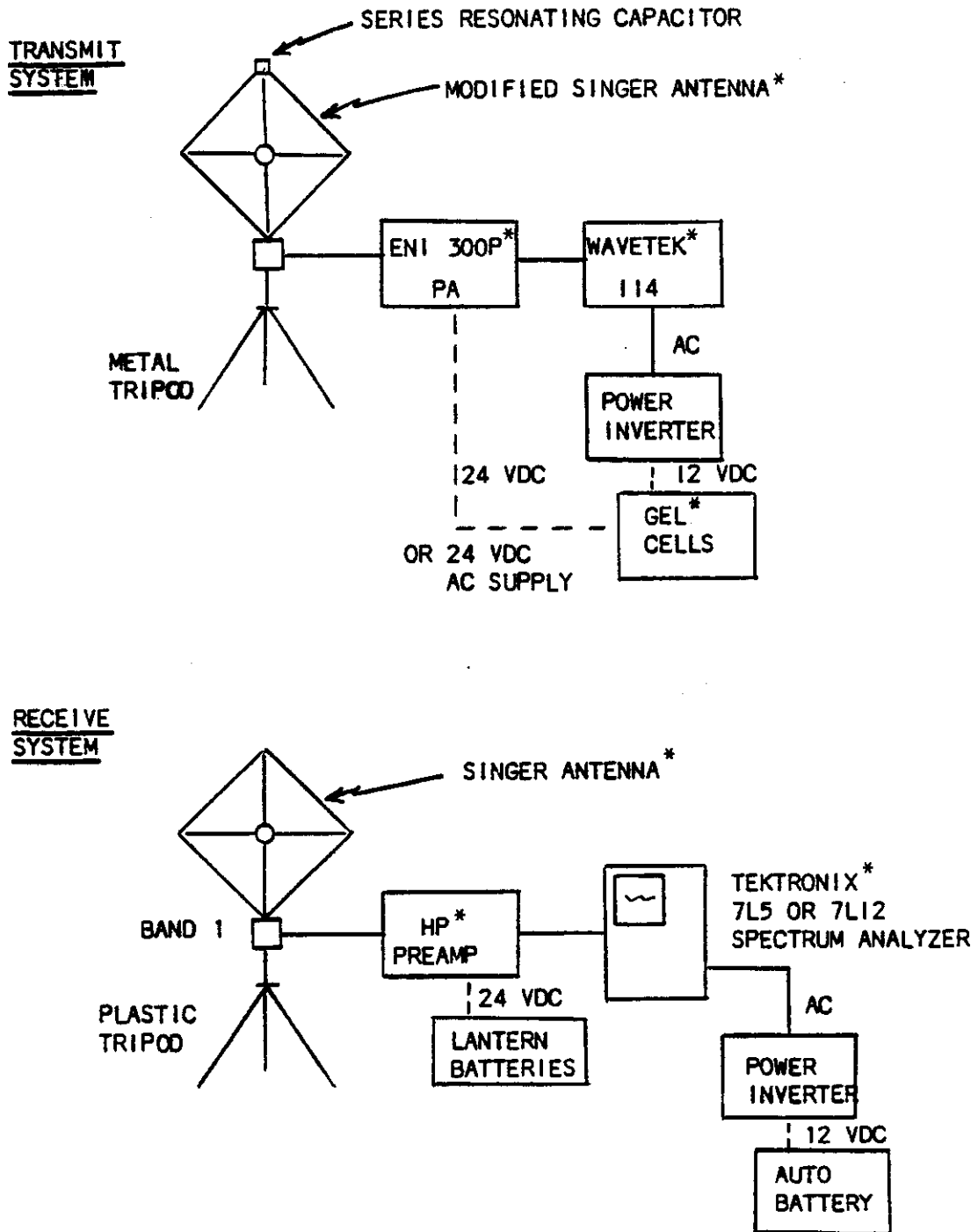

*Reference to specific brands, equipment, or trade names in this report is made to facilitate understanding and does not imply endorsement by the Bureau of Mines

FIGURE 5
HIGH-FREQUENCY (HF) SWEPT-FREQUENCY TEST
SYSTEM EQUIPMENT CONFIGURATION

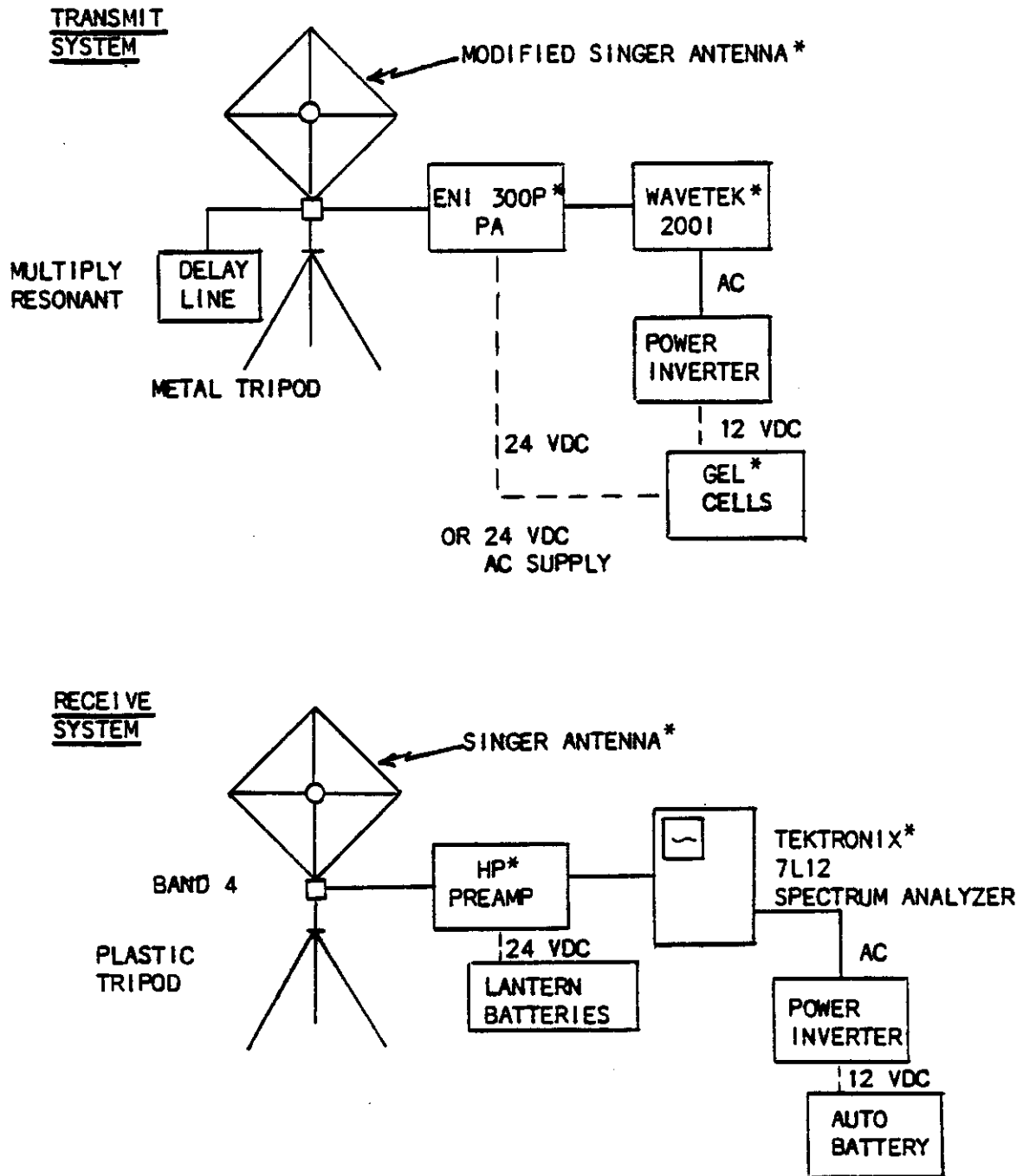

*Reference to specific brands, equipment, or trade names in this report is made to facilitate understanding and does not imply endorsement by the Bureau of Mines

FIGURE 6
 VERY-HIGH-FREQUENCY (VHF) SWEPT-FREQUENCY TEST
 SYSTEM EQUIPMENT CONFIGURATION

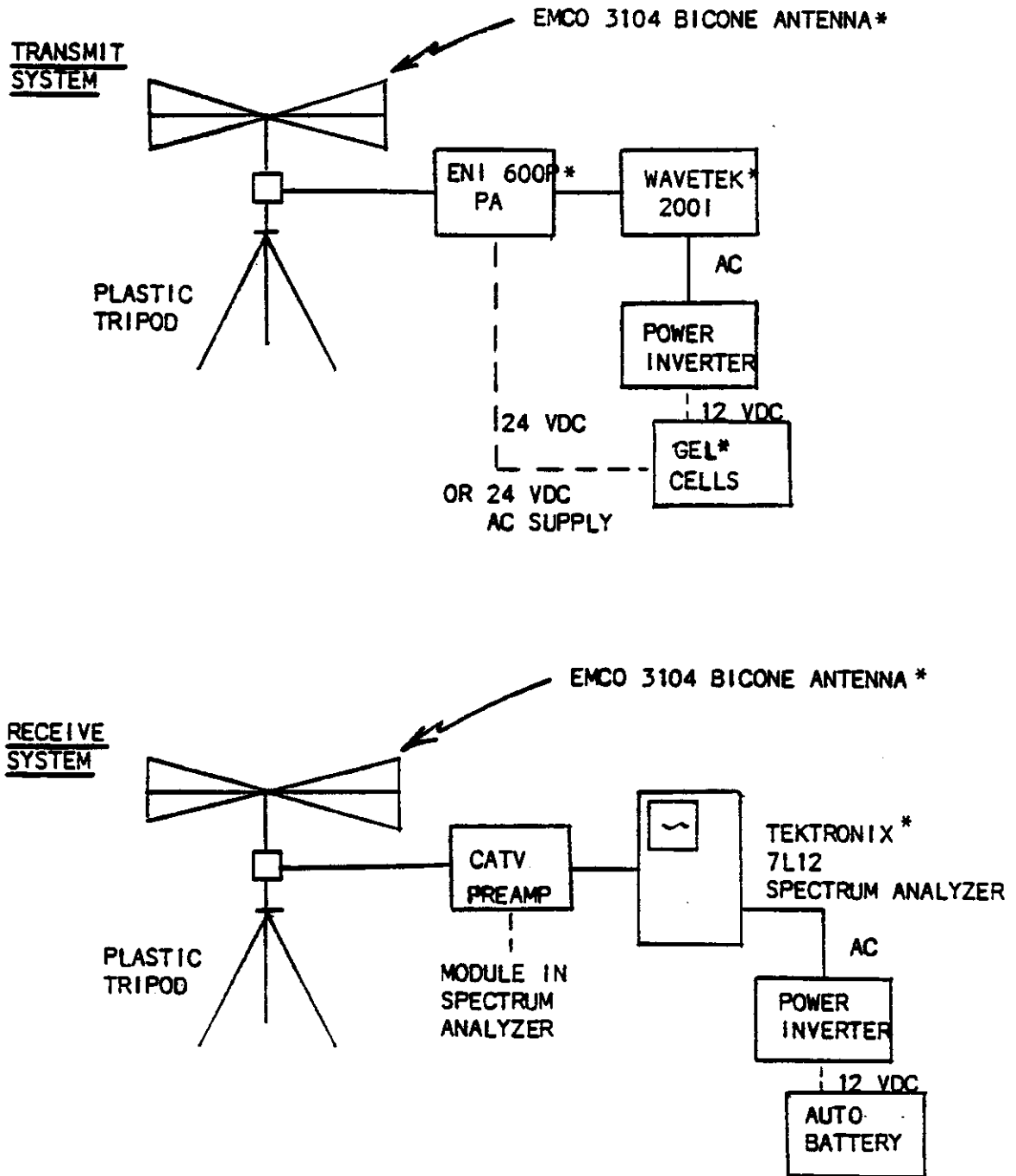

*Reference to specific brands, equipment, or trade names in this report is made to facilitate understanding and does not imply endorsement by the Bureau of Mines

FIGURE 7
 ULTRA-HIGH-FREQUENCY (UHF) SWEPT-FREQUENCY TEST
 SYSTEM EQUIPMENT CONFIGURATION

TRANSMIT SYSTEM

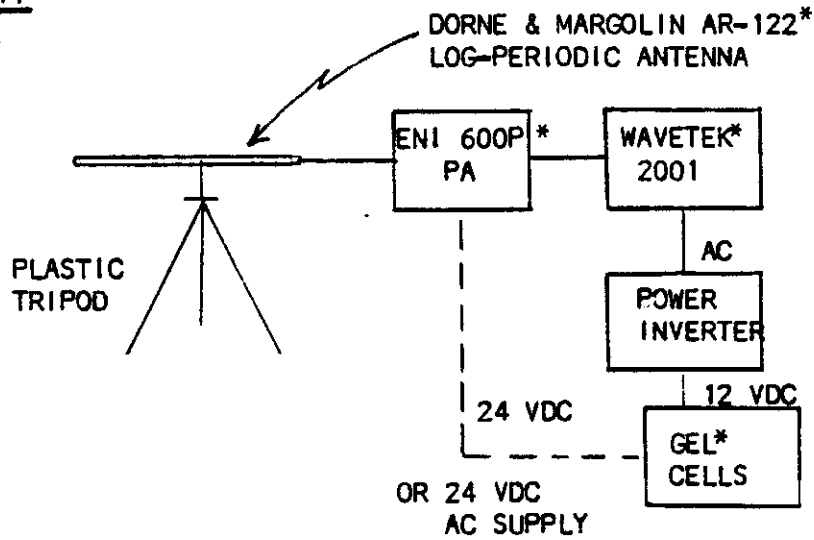

RECEIVE SYSTEM

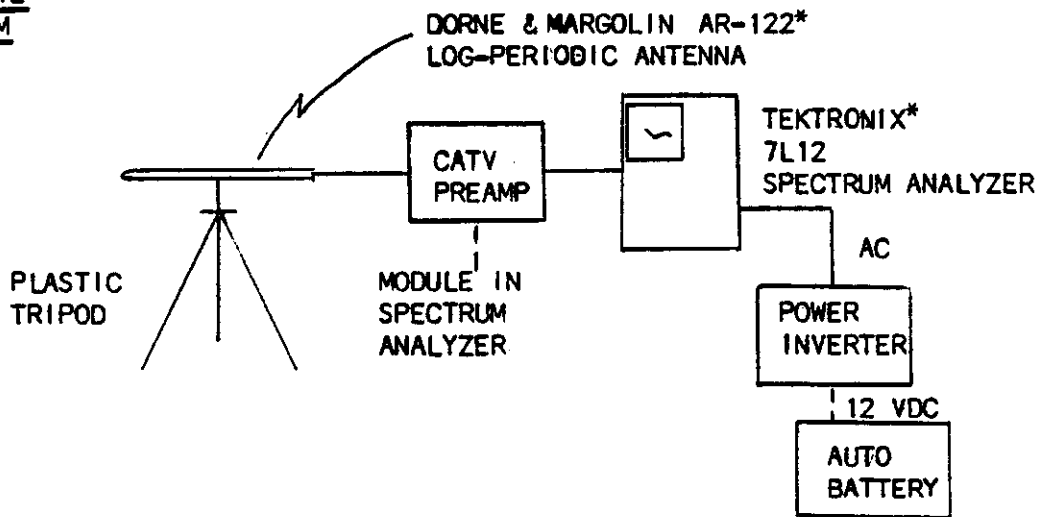

*Reference to specific brands, equipment, or trade names in this report is made to facilitate understanding and does not imply endorsement by the Bureau of Mines

The key elements in the swept-frequency system were Tektronix* 7L5 or 7L12 spectrum analyzer modules used as receivers in a Tektronix* 7603 storage oscilloscope mainframe. The analyzers operated asynchronously with respect to the swept frequency output of one of two Wavetek* sweep generators in MF, HF, VHF and UHF bands. Data was recorded on oscillographs. Particular lists of equipment and test system parameters follow:

Medium Frequency (MF) Tests (nominally 0.2-1 MHz)

Transmit System:

- Wavetek* Model 114 sweep signal generator
switch "ff", X3, X1 set to X1
frequency, Hz set to 100K
sweep mode set to cont. w/sweep
(align red & black lines)
slope/level set to -1, red line "up"
sweep rate: black on 0.1
 red on 1
frequency dial set to 0.5
amplitude set to minimum value
- ENI* 300P power amplifier
1-watt output into 50 ohms
- modified Singer* shielded loop antenna broadly series
resonated to 0.65 MHz, area = 0.73 square
meters
 or
Stoddard* current probe
- batteries and inverter as shown in Figure 4.

Receive System:

- Singer* NM-25 loop antenna set to band-1
- Hewlett Packard* 08640-060506 low noise preamp
(33 dB gain in MF band)

* Reference to specific brands, equipment, or trade names in this report is made to facilitate understanding and does not imply endorsement by the Bureau of Mines.

- Tektronix* 7L5 spectrum analyzer
 - 500 KHz dot frequency
 - 100 KHz/division
 - 30 KHz resolution
 - 10 dB/division log amplitude
 or
 - Tektronix* 7L12 spectrum analyzer
 - 100 KHz/division
 - 30 KHz resolution
 - 10 dB/division log amplitude
- trace start marker at left graticule line

High Frequency (HF) Tests (nominally 2-20 MHz)

Transmit System:

- Wavetek* Model 2001 sweep signal generator
 - output set to -10 dBm
 - mode switch on S/S
 - band-1
 - sweep time set to 1:1
 - carefully adjust frequency limits
- ENI* 300P power amplifier
 - 1-watt output into 50 ohms
- modified Singer* shielded loop antenna with 100 feet of RG-8 cable serving as a delay line with resonant peaks at 2.0, 4.4, 7.9, 14.4, 18.0 MHz
 - or
 - Stoddard* current probe
- batteries and inverter per Figure 5.

Receive System:

- Singer* NM-25 loop antenna set to band 4
- Hewlett Packard* 08640-060506 low noise preamp with gain as shown in Figure 5.

* Reference to specific brands, equipment, or trade names in this report is made to facilitate understanding and does not imply endorsement by the Bureau of Mines.

- Tektronix* 7L12 spectrum analyzer
 - 2 MHz/division
 - 300 KHz resolution
 - 10 dB/division log amplitude
 - trace start marker at left graticule line

Very High Frequency (VHF) tests (nominally 20-200 MHz)

Transmit System:

- Wavetek* Model 2001 sweep signal generator
 - output set to -10 dBm
 - mode switch set to S/S
 - band 1
 - sweep time set to 1:1
 - carefully adjust frequency limits
- ENI* 600L or 600P power amplifier
 - 1-watt into 50 ohms
- EMCO* 3104 biconical antenna
 - broadband
- batteries and inverter as shown in Figure 6.

Receive System:

- EMCO* 3104 biconical antenna
 - broadband
- Tektronix* 7K11 CATV preamp
 - set to 0 dBmV
- Tektronix* 7L12 spectrum analyzer
 - 20 MHz/division
 - 3 MHz resolution
 - 10 dB/division log amplitude
 - trace start marker at left graticule line

* Reference to specific brands, equipment, or trade names in this report is made to facilitate understanding and does not imply endorsement by the Bureau of Mines.

Ultra High Frequency (UHF) Tests (nominally 200-1000 MHz)

Transmit System:

- Wavetek* Model 2001 sweep signal generator
output set to -10 dBm
mode switch set to S/S
band 1, band 2 (500 MHz crossover)
(2 oscillographs required)
sweep time set to 1:1
wide-open band limits
- ENI* 600L or 600P power amplifier
1-watt into 50 ohms
- Dorne & Margolin* AR122 log periodic antenna
broadband
- batteries and inverter as shown in Figure 7.

Receive System:

- Dorne & Margolin* AR122 log periodic antenna
broadband
- Tektronix* 7K11 CATV preamp
set to 0 dBmV
- Tektronix* 7L12 spectrum analyzer
100 MHz/division
3 MHz resolution
10 dB/division log amplitude
trace start marker at left graticule line.

Continuous wave tests used the same transmit system as the swept-frequency tests with frequency generators operated on a CW basis or, alternatively, Collins* MF 520 KHz 1-watt portable radios and tuned loops. The CW receiving equipment consisted of the Singer* NM-25 field strength meter for MF/HF tests and the Fairchild* EMC-25 field strength meter for VHF/UHF tests. The MF/HF receiving antenna was a standard Singer* calibrated loop. The VHF/UHF receiving antennas were biconical or log periodic antennas. The X-band microwave test set-up, illustrated in Figure 8, used a Microwave Associates* 86656CM source and a Singer* NM-65 field strength meter each operating with Narda* horn antennas.

* Reference to specific brands, equipment, or trade names in this report is made to facilitate understanding and does not imply endorsement by the Bureau of Mines

FIGURE 8
MICROWAVE CW TEST SYSTEM EQUIPMENT CONFIGURATION

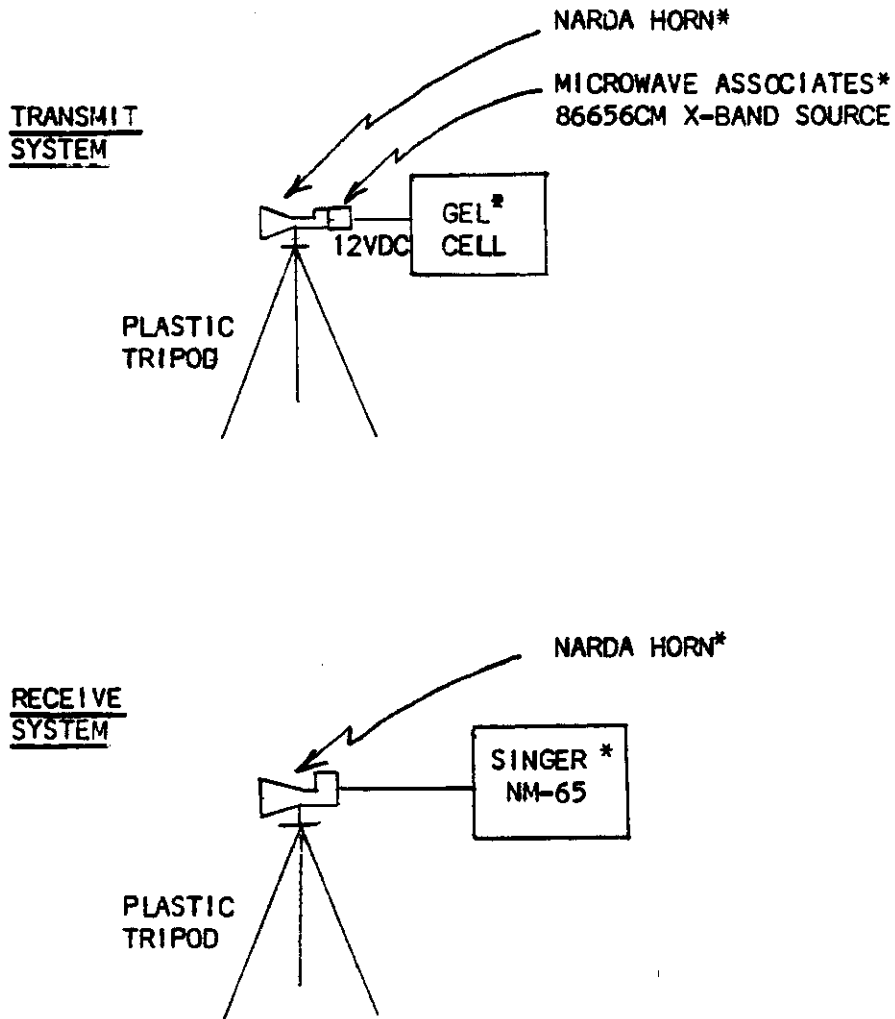

*Reference to specific brands, equipment, or trade names in this report is made to facilitate understanding and does not imply endorsement by the Bureau of Mines

3.1.2 TEST AND PRACTICAL SYSTEM CHARACTERISTICS

The characteristic test system parameters are the transmit current moment and conversion factors relating received signal levels to incident magnetic and electric field strengths. Transmit moment and receive signal sensitivity parameters are used to perform data normalization for practical operating systems. A modified set of correction factors can be used for normalization of the test system measured data to practical systems.

The most appropriate representation of current moment is the quasi-static purely geometric limit of INA (product of current, number of loop turns and the loop area in square meters) for loop antennas, and Ih_e (product of base current and effective height, h_e) for dipole/monopole electric antennas. For the quasi-static induction field case, these representations are equivalent. These quasi-static terms must be modified to represent the radiation field moments at substantial distances from the antennas where, to achieve equivalence with Ih_e , the magnetic current moment must be multiplied by 2 times pi times the inverse of the signal wavelength in meters.

For the test system, the geometric current moments have been measured as part of the system calibration process. For practical systems, the current moments have been calculated for man-carried and/or vehicular applications involving a nominal 0.2 square meter loop and a 0.375 meter high VHF or a quarterwave UHF whip assuming 1-watt of available power equivalent to that from the test system.

Loop transmit moments (INAs) were computed as a composite of multi-turn (2-10 turn) loop parametric data derived from a proven multi-turn loop design algorithm previously presented by the author in the final report of Contract J0395072, Wireless Communications for Trackless Haulage Vehicles. Computed data for a 50 ohm 1 watt source exciting the antennas through a single-pole matching network is presented in Figure 9. Readily available impedance data was used for the whip antennas with computations for 1 watt from an impedance matched 50-ohm source shown in Figure 10. The loop data does not reflect either the practical upper limit for single-pole-tuned operation or the theoretical upper limit derived on a stored energy basis.

The receiving system correction factors (added directly to the dBm signals shown on the spectrum analyzer to determine the magnetic or electric field strength) are the composite sum of:

- (1) the calibrated receiving antenna factor in dB,
- (2) the measured receiving system preamplifier gain in dB
- (3) 107 dB dBm-dB V conversion,
- (4) and, for determination of the magnetic fields, -51.15 dB uVolt/m-uAmp/m conversion factor for the intrinsic free space impedance.

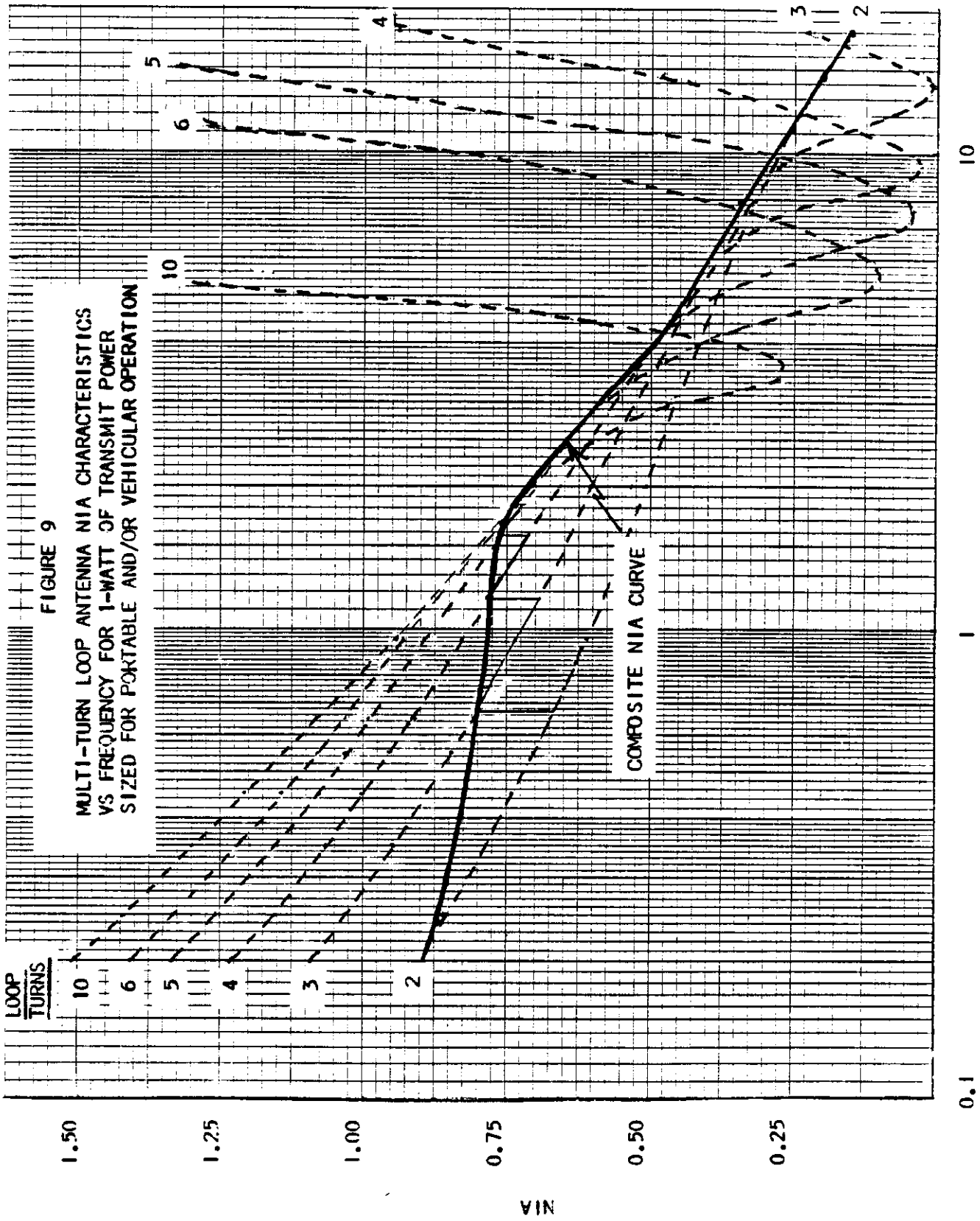
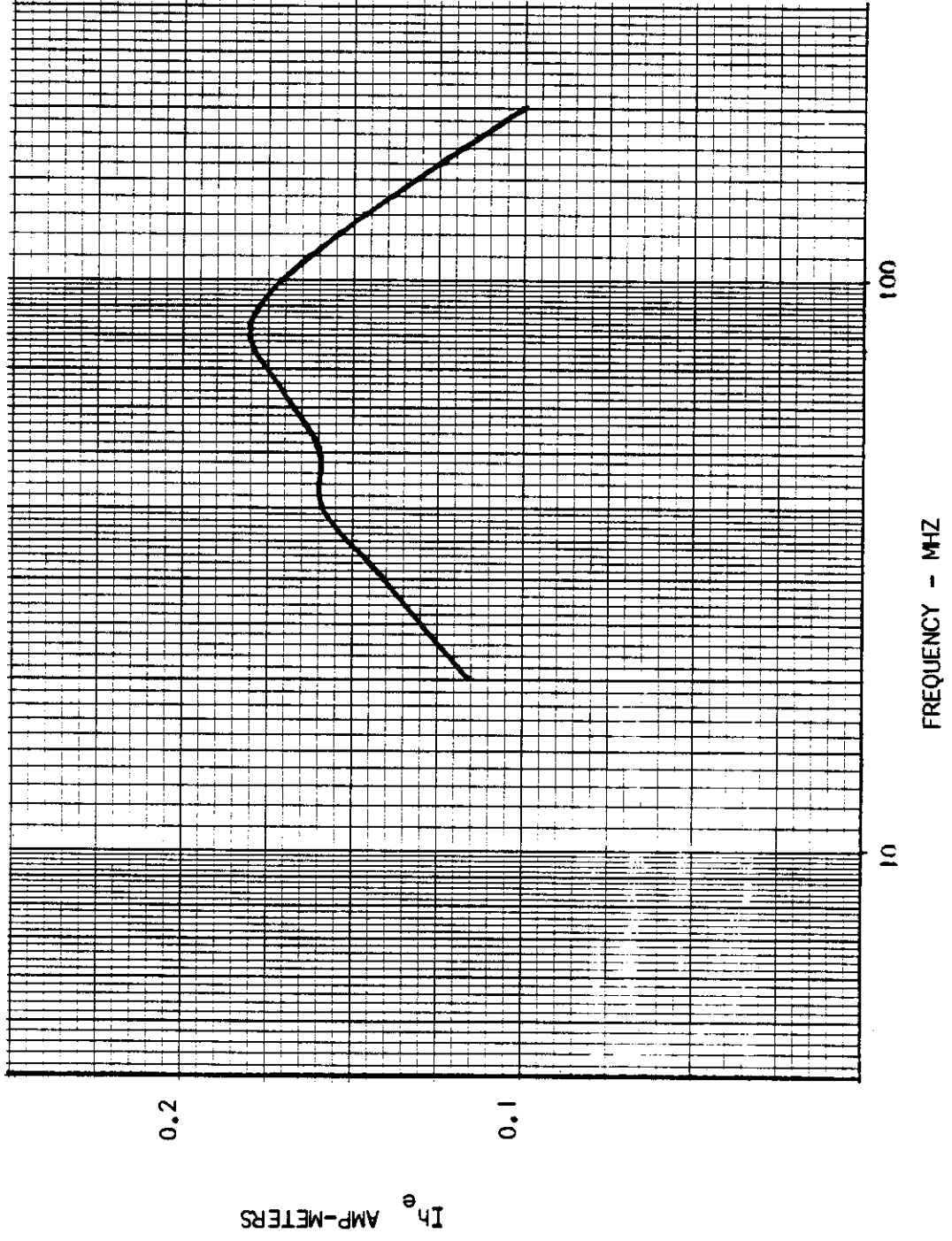

FIGURE 10
 CALCULATED PRACTICAL I_{h_e} FOR VHF FOR FIXED
 ELECTRIC WHIP ANTENNA LENGTH OF 0.375 METERS
 AND FOR 1-WATT OF TRANSMITTER POWER



Correction factors for MF/HF test and practical swept and CW systems are given in Table 2. Corresponding VHF/UHF correction factors are given in Table 3. In the individual reduced mine data of Logan Wash Mine, United Nuclear Section 23 Mine, and Kerr-McGee Hobbs Potash Mine, some of the correction factors varied from those given in these tables due to replacement of the transmit test power amplifier and due to the erroneous assumption that the gain of the preamps was independent of frequency. Correction factors and transmit coupled current values appropriate for use with the Stoddard current probes are given in Table 4.

Geometric current moments for the practical and test systems are given in Figure 11. This data may be compared with values for comparable radiation current moments given in Figure 12. For evaluating the predicted performance of "practical systems", computed receiving system sensitivity levels (based on the thermal noise limits of the loops) are given in Figure 13.

3.2 CATEGORIZATION OF TESTS & TEST ENVIRONMENTS

3.2.1 OCCIDENTAL OIL SHALE LOGAN WASH MINE

First Day Tests 9-25-80

The first day of testing was comprised solely of swept-frequency measurements. The transmitting signal sources were located at the end of the L-700 drift (South) under a non-roof-bolted section of the mine that was free of conductors for a distance of 50 or 60 feet in front of the transmitter. The transmitter was placed at the drift center and the receiving antenna was also placed in the drift center at a distance of 240 feet (nearly opposite the entry to Retort #6). Following these tests, the receiving location was moved closer to the transmitter to a range of 120 feet where the measurements were repeated. Beyond the 50-60 foot range (entrance to inventory storage area), conductors in the drift extended in the inby direction. Over the test range, the roof height varied between 10 and 20 feet and the drift width varied between 30-40 feet. The geometry of these tests is illustrated on the mine map of Figure 14.

Second Day Tests 9-26-80

On the second day, CW VHF and UHF tests with range along the L-700 drift were performed at test frequencies of 80, 150, 500, and 800 MHz. The transmitter location was the same as that used the first day for the swept-frequency tests.

TABLE 2
MF & HF MAGNETIC FIELD STRENGTH CORRECTION FACTORS

FREQUENCY (MHZ)	TEST SYSTEM		PRACTICAL SYSTEM	
	SWEPT (DB)	CW (DB)	SWEPT (DB)	CW (DB)
0.2	69.5	- 4.5	83.3	9.3
0.25	69.7	- 4.3	82.2	8.2
0.35	69.4	- 4.6	80.6	6.6
0.45	68.5	- 5.5	78.1	4.1
0.55	67.0	- 7.0	72.4	- 1.6
0.65	65.1	- 9.0	65.9	- 8.2
0.75	63.3	-10.7	69.0	- 5.2
0.85	60.7	-13.3	71.4	- 2.6
0.95	59.0	-15.0	72.6	- 1.4
2.0	62.0	-12.5	68.8	- 5.7
4.4	52.4	-22.5	53.6	-21.3
7.9	51.6	-24.0	53.1	-22.5
11.2	50.7	-25.5	51.6	-24.6
14.4	50.0	-27.0	53.7	-23.3
18.0	49.7	-29.0	53.0	-25.7

TABLE 3

VHF & UHF ELECTRIC FIELD STRENGTH CORRECTION FACTORS

FREQ(MHZ)	TEST SYSTEM		PRACTICAL SYSTEM			
	SWEPT(DB)	CW(DB)	MINES #1 & #2 ONLY		SWEPT(DB)	CW(DB)
	SWEPT(DB)	CW(DB)	SWEPT(DB)	CW(DB)	SWEPT(DB)	CW(DB)
20	105.1	12.0	102.7	11.7	104.7	13.7
30	103.0	10.6	100.1	10.7	103.1	13.7
40	103.3	12.7	104.2	15.6	107.2	18.6
50	105.7	12.7	104.2	15.7	108.7	20.2
60	102.9	9.2	98.1	9.4	103.1	14.4
70	102.9	8.4	97.2	8.2	102.7	13.7
80	103.1	8.2	97.1	7.7	102.6	13.2
90	104.7	9.5	99.6	9.9	105.1	15.4
100	108.0	12.3	105.5	15.8	111.5	21.8
110	104.8	14.4	104.8	20.4	110.8	26.4
120	109.8	14.5	108.1	19.0	114.2	25.1
130	109.4	13.5	108.0	19.0	113.8	24.8
140	108.1	14.5	105.1	16.2	110.8	21.9
150	108.8	14.4	106.8	18.0	112.3	23.5
160	108.9	14.5	106.1	17.2	111.7	22.8
170	109.0	14.6	106.0	17.1	111.6	22.7
180	111.3	16.5	109.4	20.4	115.1	26.1
190	112.3	17.6	110.8	21.8	116.5	27.5
200	112.6	17.8	110.8	21.7	116.5	27.4
200	107.2	12.9	103.3	14.2	108.5	19.4
300	112.3	16.4	111.6	21.2	117.1	26.7
400	114.6	19.8	117.9	28.1	122.9	33.1
500	114.1	20.8	120.1	30.0	123.3	33.2
600	118.4	21.9	123.2	32.2	128.7	37.7
700	119.4	22.7	125.0	33.8	130.5	39.3
800	121.7	23.3	126.5	35.1	133.5	42.1
900	122.4	24.8	129.6	38.1	135.6	44.1
1000	119.6	24.8	130.0	38.0	132.8	40.8

TABLE 4
MAGNETIC FIELD STRENGTH DATA CORRECTION FACTORS
FOR USE WITH STODDARD CURRENT PROBE

FREQUENCY (MHZ)	FACTOR (DB)
0.2	64.5
0.25	64.0
0.35	62.4
0.45	61.8
0.55	61.3
0.65	61.0
0.75	60.8
0.85	60.6
0.95	60.5
2.0	60.0
4.4	59.5
7.9	59.2
11.2	59.1
14.4	59.0
18.0	59.0

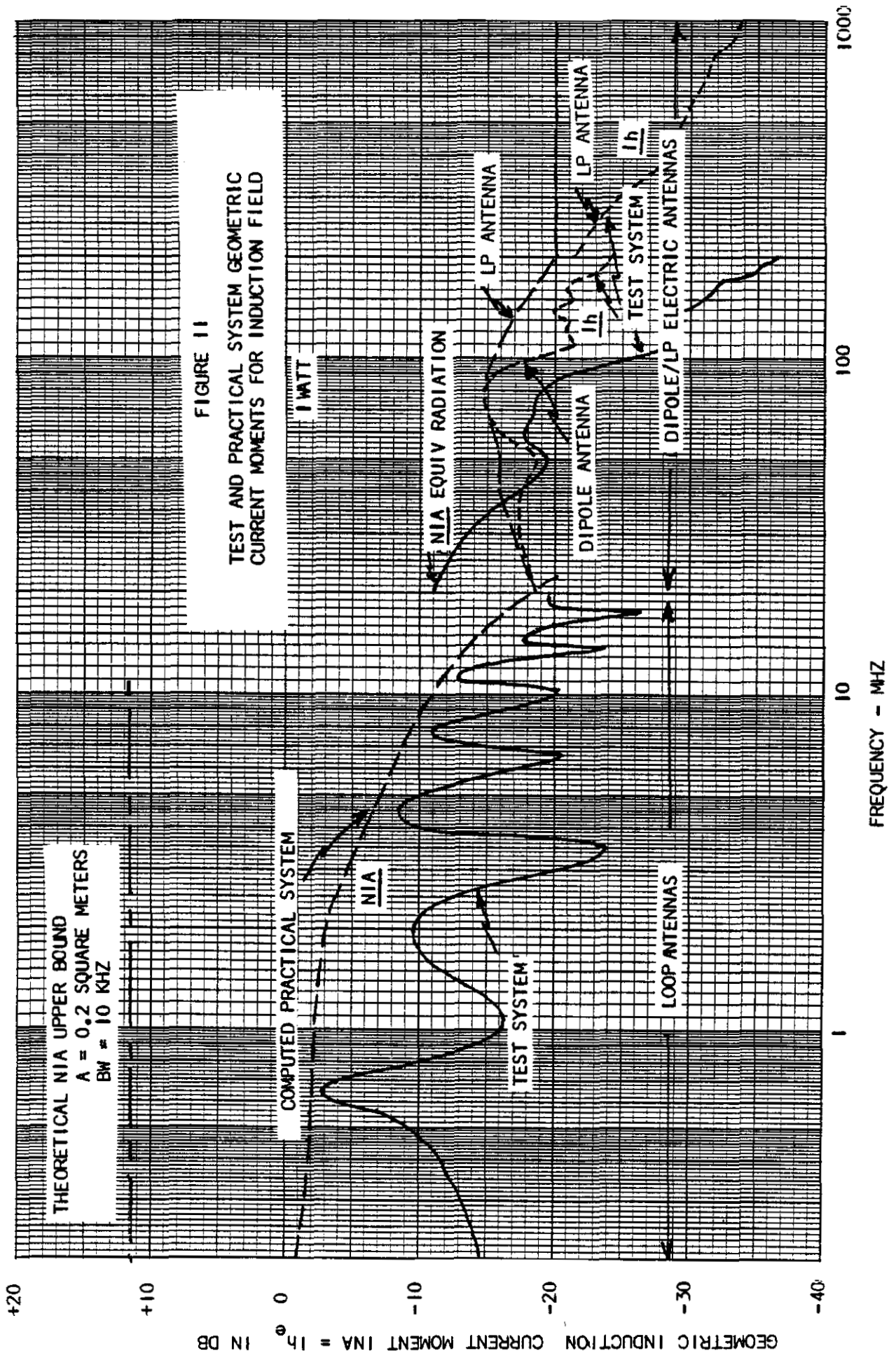

FIGURE 11
 TEST AND PRACTICAL SYSTEM GEOMETRIC
 CURRENT MOMENTS FOR INDUCTION FIELD

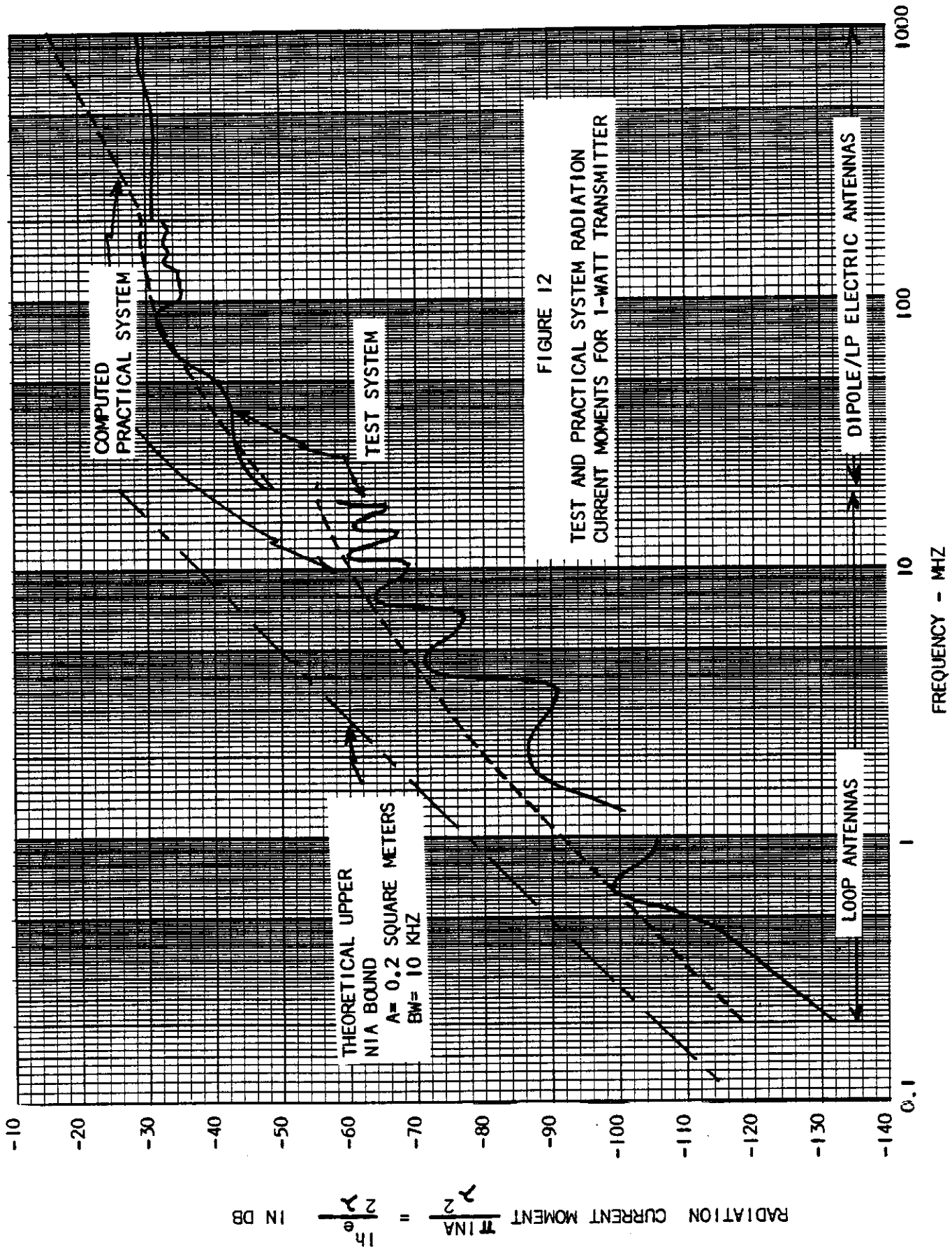

FIGURE 12
 TEST AND PRACTICAL SYSTEM RADIATION
 CURRENT MOMENTS FOR 1-WATT TRANSMITTER

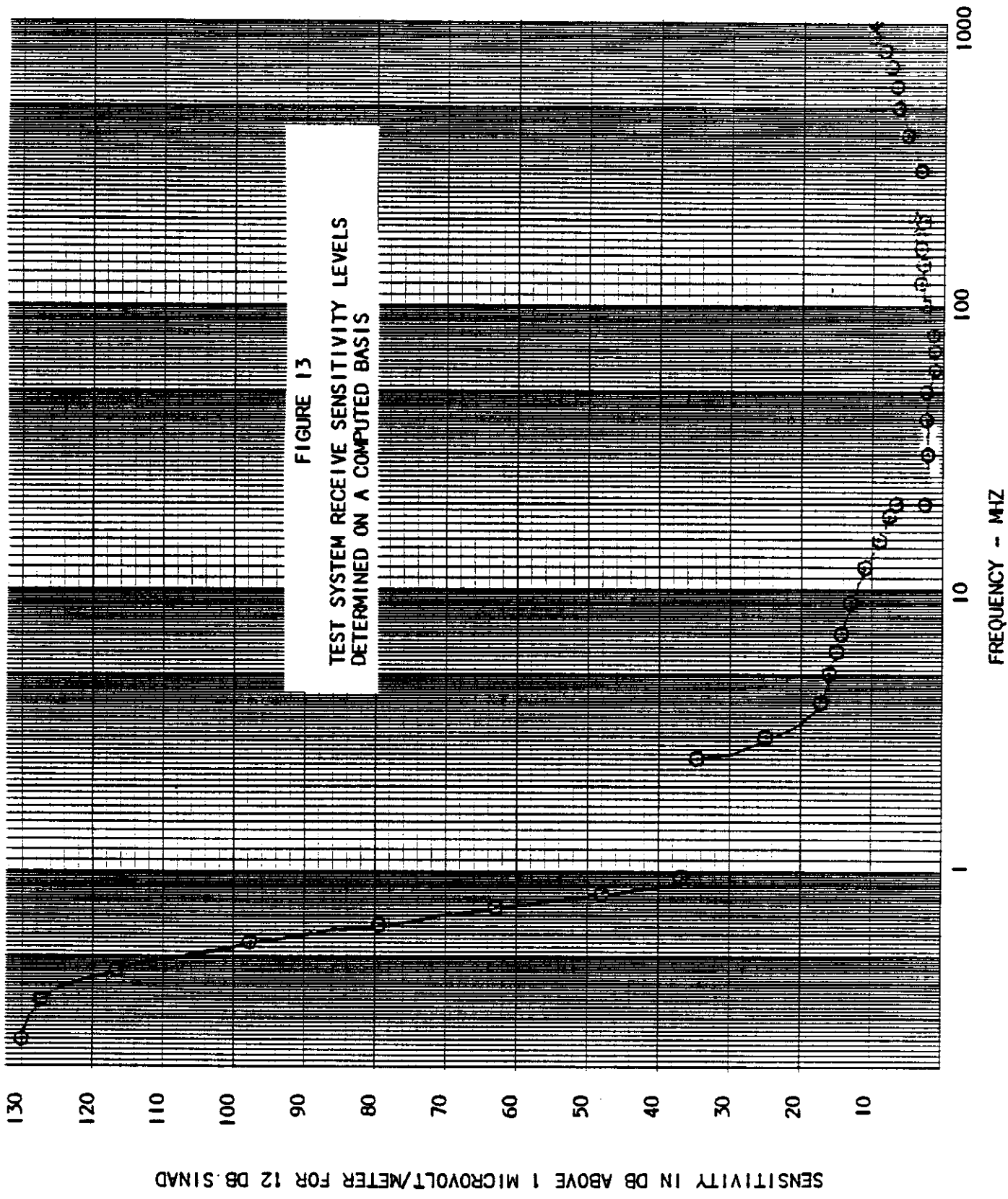

FIGURE 13
 TEST SYSTEM RECEIVE SENSITIVITY LEVELS
 DETERMINED ON A COMPUTED BASIS

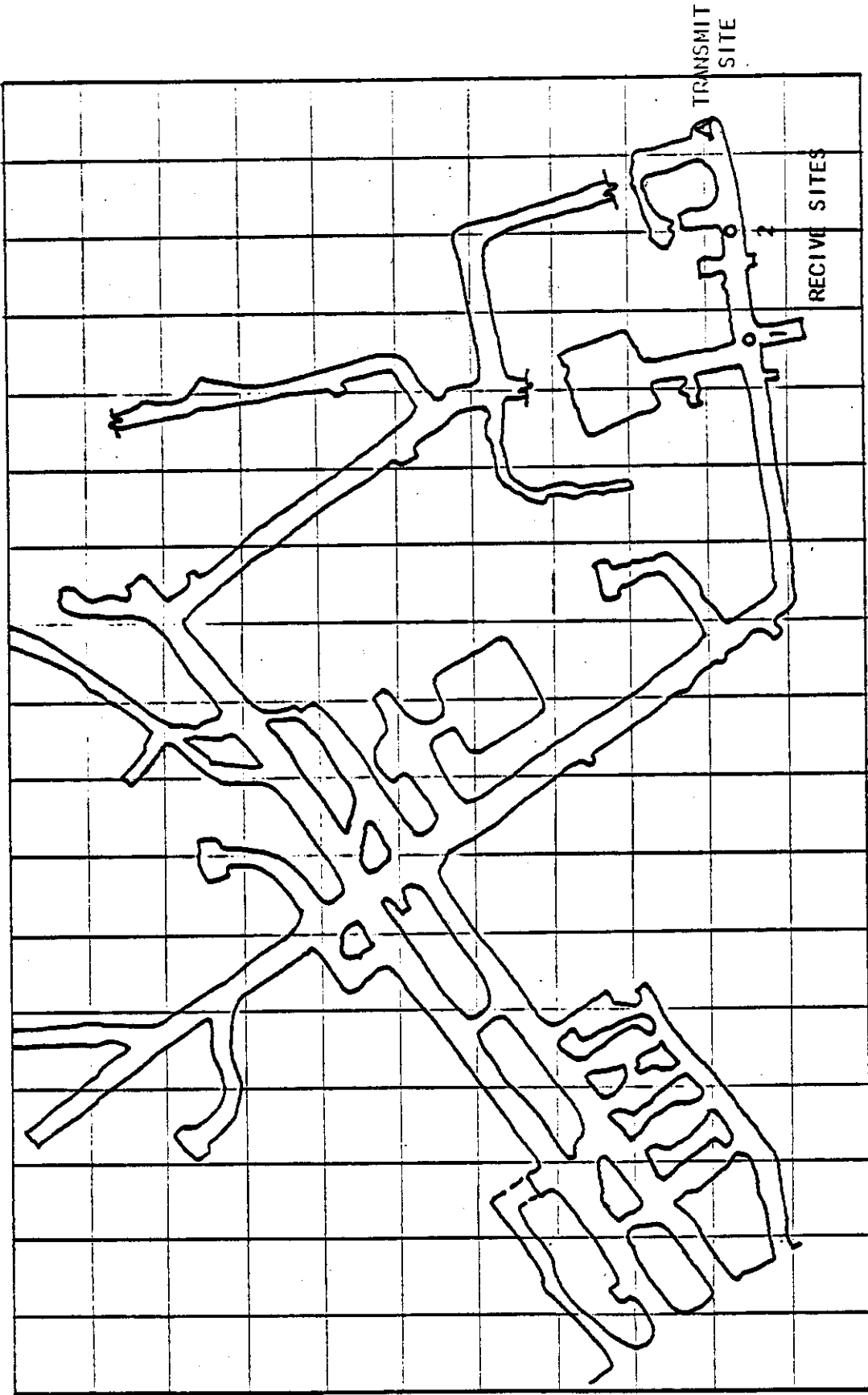

FIGURE 14
OCCIDENTAL OIL SHALE LOGAN WASH MINE
SWEEP FREQUENCY MEASUREMENT LOCATIONS

Additionally, as the transmit location was in a conductor-free area, MF CW tests were performed at frequencies of 250, 650, and 1000 KHz. The test geometries for the second day of testing are shown in the mine maps of Figures 15 and 16.

Third Day Tests 9-27-80

MF CW tests of loop-excited and current-probe-excited monofilar transmission modes were performed during the third day. For the antenna excitation test, the transmit loop was placed in the drift center in the coplanar HMD orientation. The probe-excited tests were conducted with the probe coupled to the phone line near Retort #6 where the access to the middle level was located.

Additionally, a CW microwave test was conducted in the conductor-free area of the L-700 drift. This test was conducted along a straight line and also around a corner employing the 4-foot plane reflector.

Geometries of the third day tests are given in the mine maps of Figures 17 and 18.

3.2.2 UNITED NUCLEAR/HOMESTAKE PARTNERS SECTION 23 MINE

All testing, except for the MF CW measurements on the phone line, was conducted in two areas of the mine. The primary test area was along the Wagner 650 level drifts. The secondary test area was on the 650 tracked level near the portal shaft. The MF CW tests were conducted using a current probe on the phone line at the primary Wagner area transmit location with the receiving NM-25 field strength meter being removed as far as the 726 level 58 East track and the 780 drift track. The specific test locations are depicted on the mine maps of Figures 19 and 20. The CW test locations are designated by letters A through I. The primary and secondary transmitting and receiving locations are designated by T and R respectively.

Data taken in the primary Wagner test area for VHF CW tests and MF CW tests coupled to the 480 VAC line at test locations 0 through 8 are shown in Figures 21 and 22. The microwave range tests were conducted between sites 0 and 1; the microwave depolarization tests were conducted between T and R, with the reflector placed at R and the measured signal being received after reflection in the short drift to the mining level raise.

First Day Tests 11-28-80

The first day of testing consisted of conducting all swept-frequency tests.

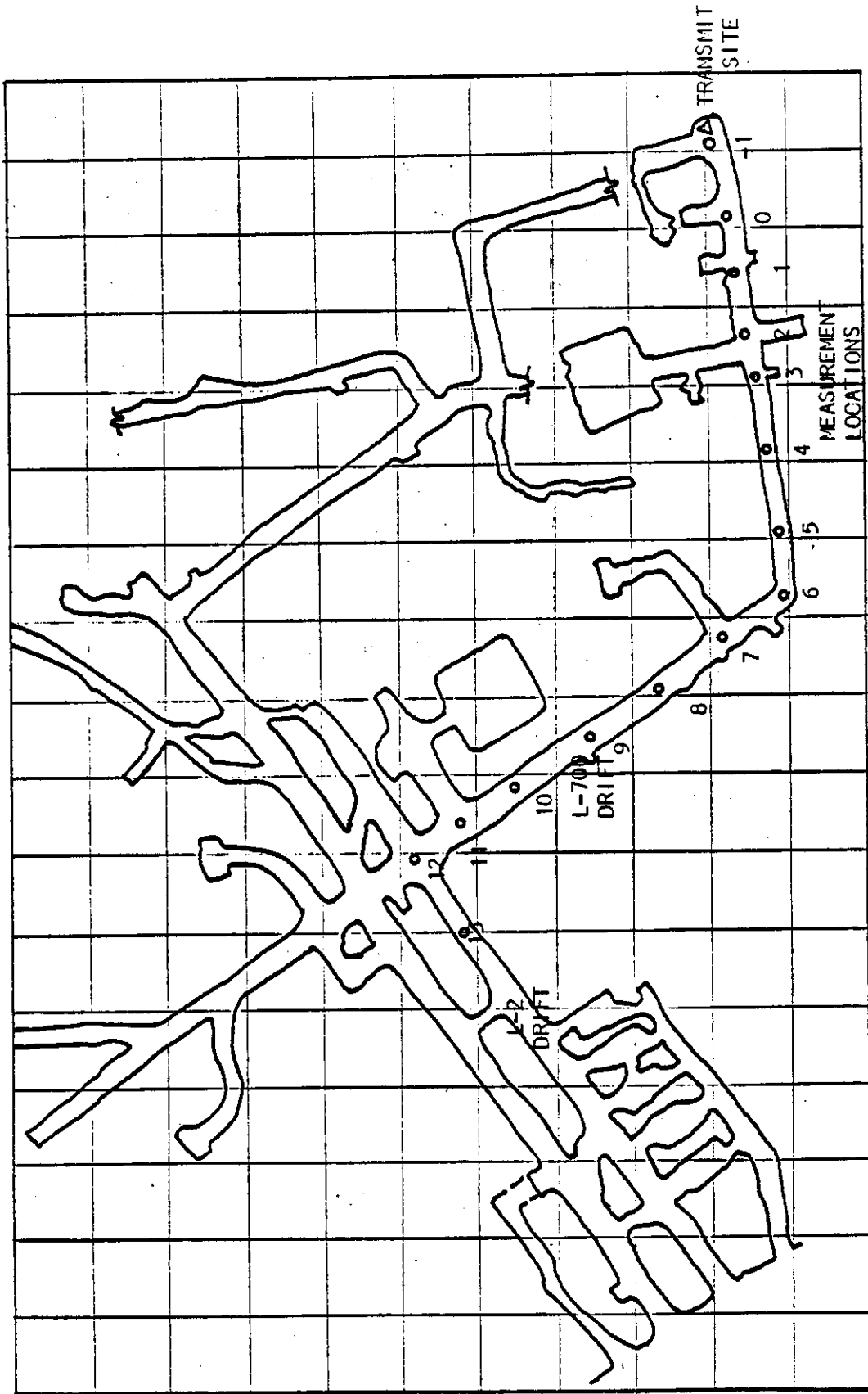

FIGURE 15
 OCCIDENTAL OIL SHALE LOGAN WASH MINE
 VHF/UHF CW FIELD STRENGTH MEASUREMENT
 LOCATIONS

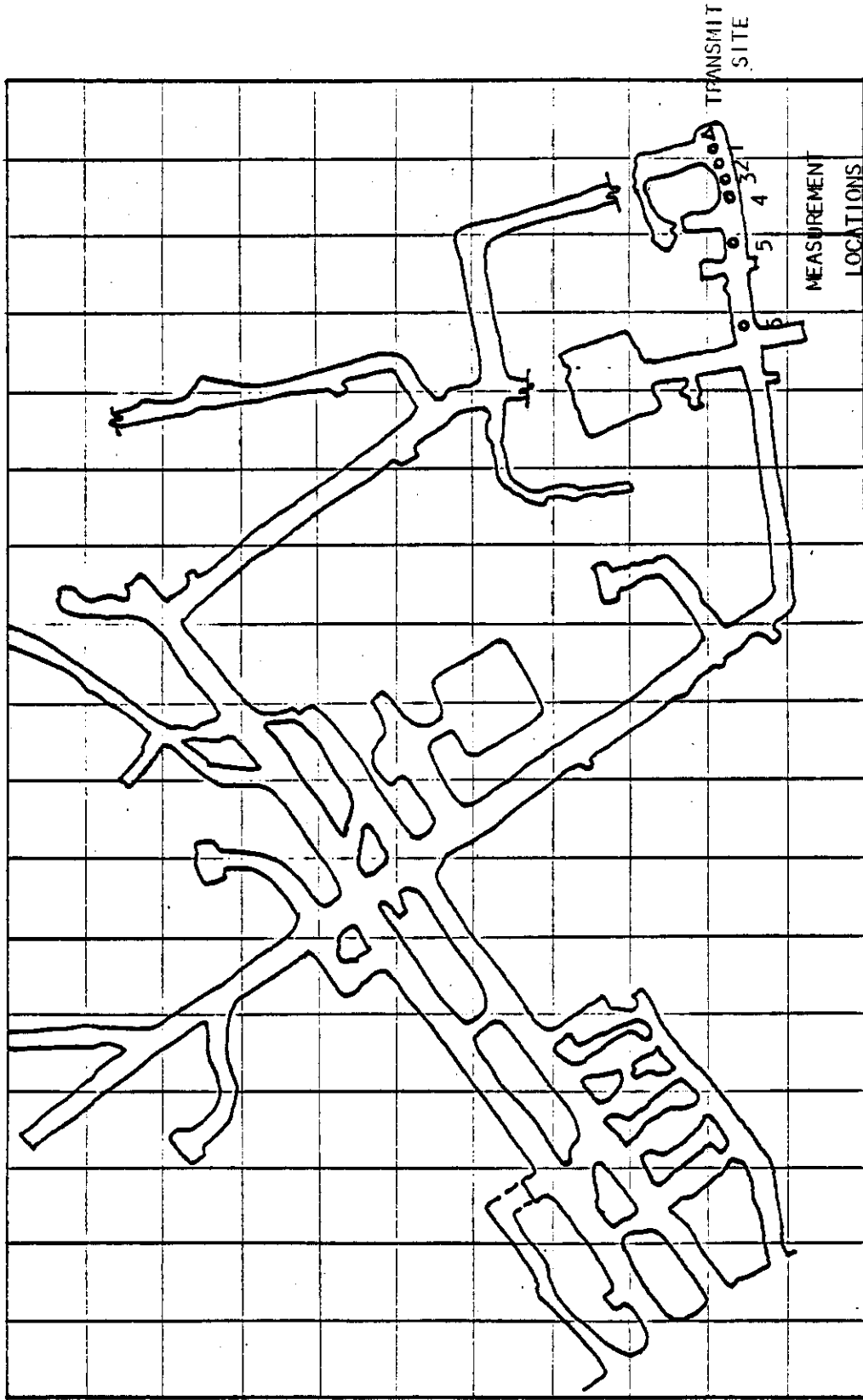

FIGURE 16
 OCCIDENTAL OIL SHALE LOGAN WASH MINE
 MEDIUM FREQUENCY CW FIELD STRENGTH MEASUREMENT
 LOCATIONS

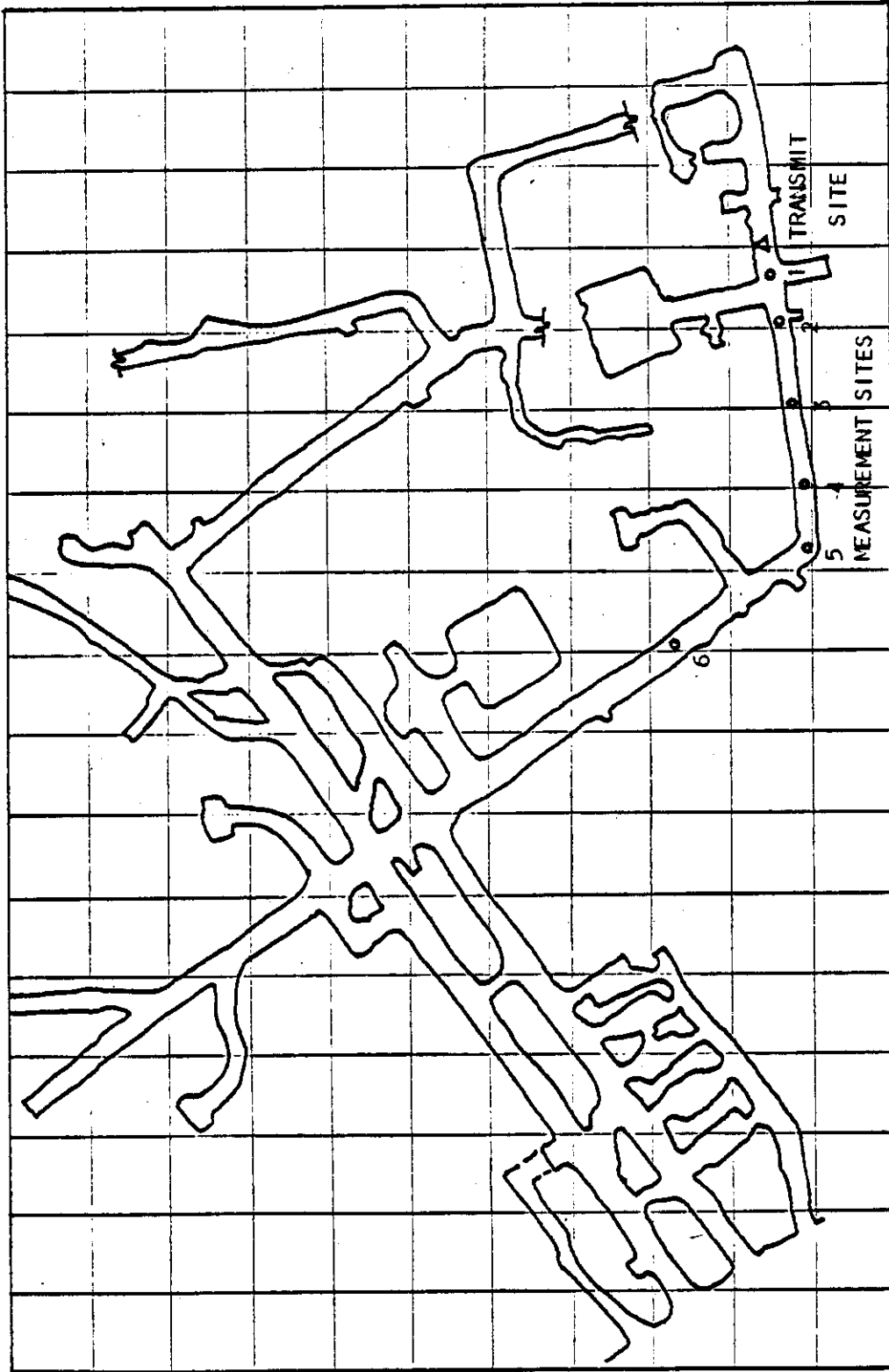

FIGURE 17
 OCCIDENTAL OIL SHALE LOGAN WASH MINE
 LOOP EXCITED MONOFILAR MODE 650KHZ FIELD STRENGTH
 MEASUREMENT LOCATIONS

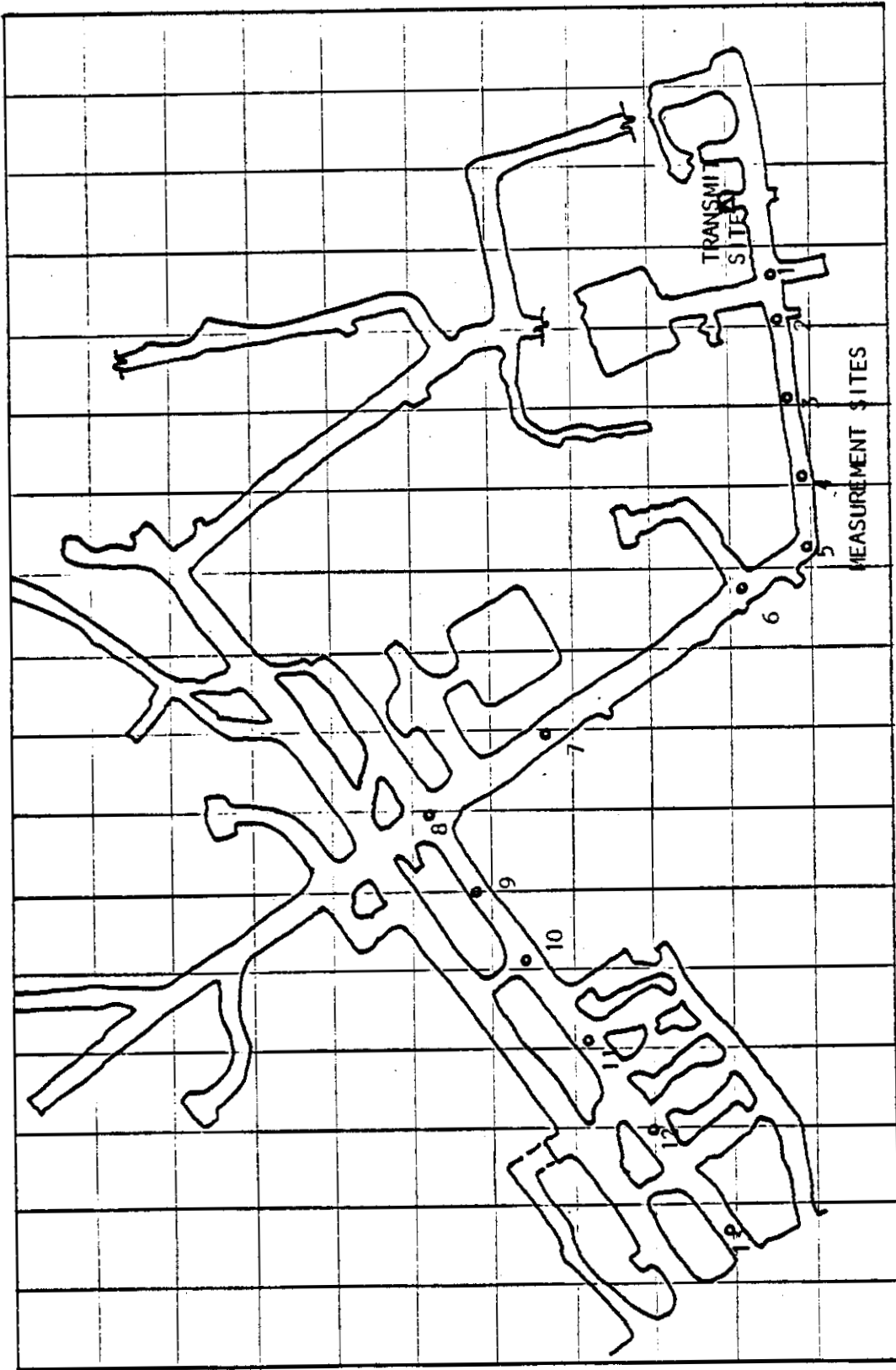

FIGURE 18
OCCIDENTAL OIL SHALE LOGAN WASH MINE
CURRENT PROBE EXCITED MONOFILAR MODE
650KHZ FIELD STRENGTH MEASUREMENT LOCATIONS

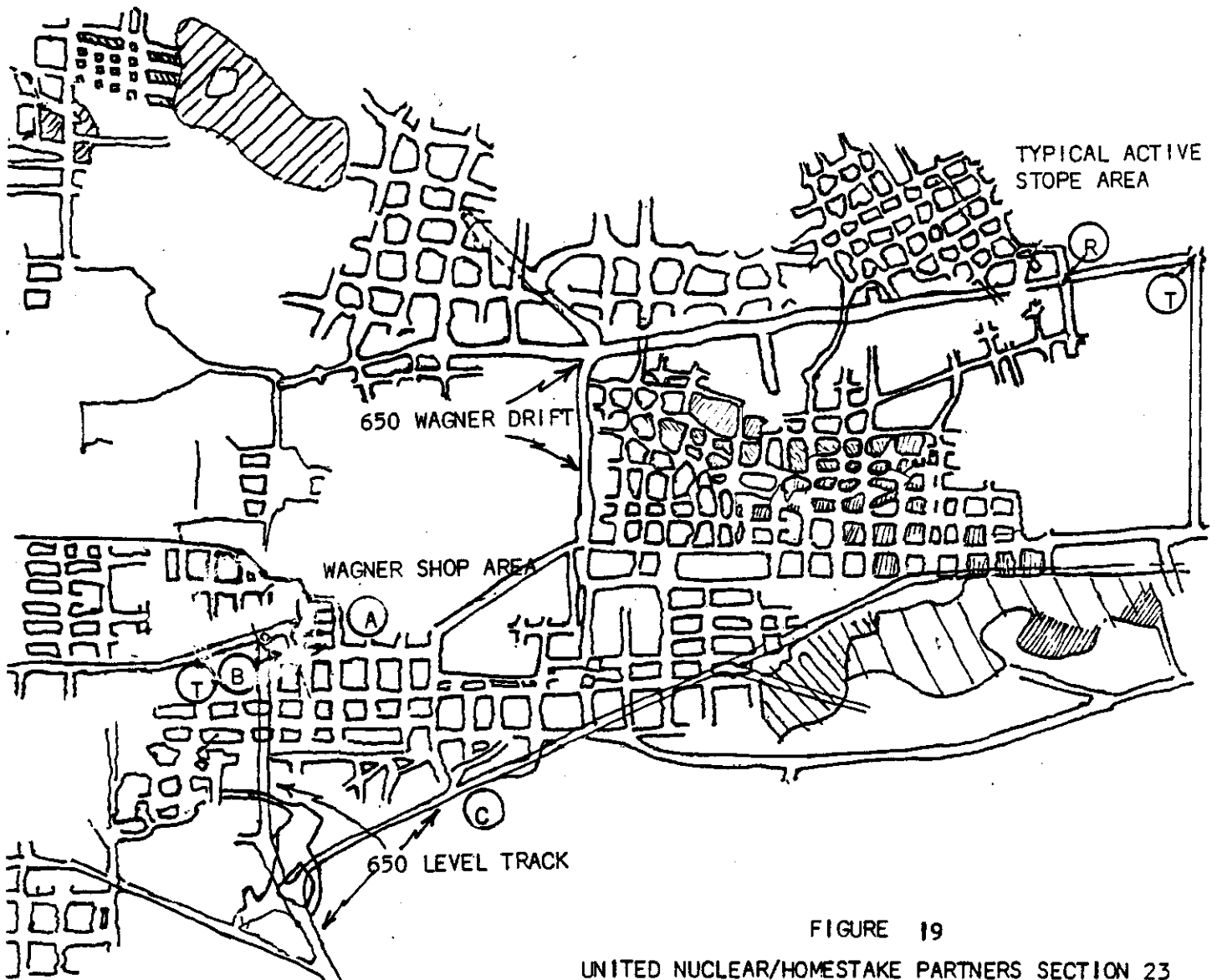
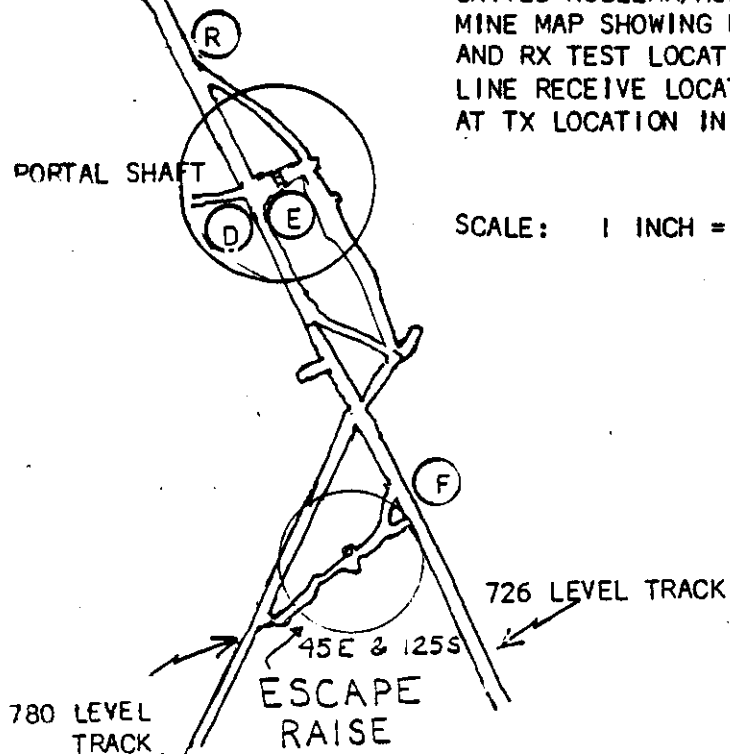

FIGURE 19

UNITED NUCLEAR/HOMESTAKE PARTNERS SECTION 23
 MINE MAP SHOWING MAIN SWEEP MEASUREMENT TX
 AND RX TEST LOCATIONS AND MF COUPLED PHONE
 LINE RECEIVE LOCATIONS (MF COUPLED PROBE
 AT TX LOCATION IN WAGNER DRIFT)

SCALE: 1 INCH = 200 FEET



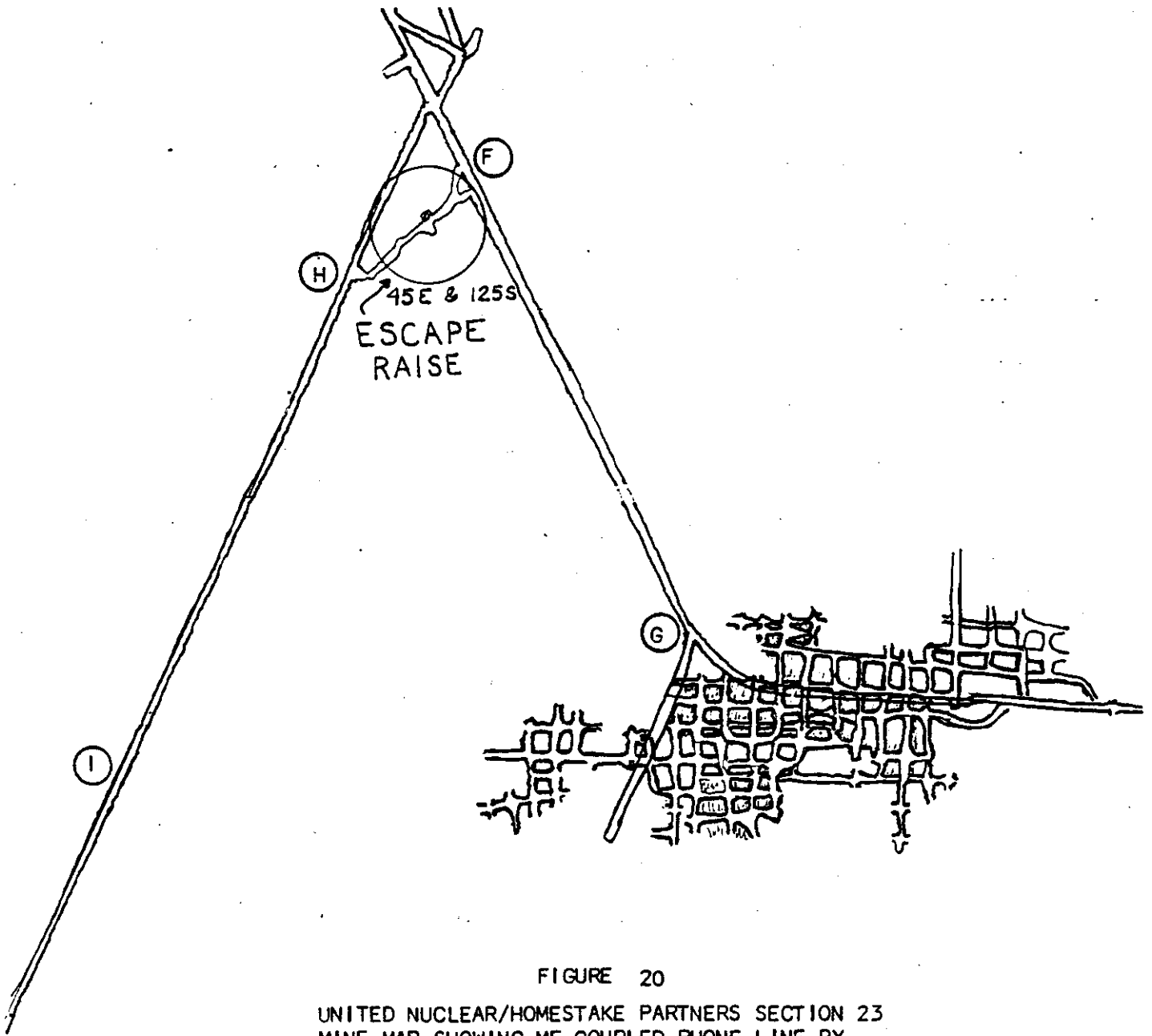

FIGURE 20

UNITED NUCLEAR/HOMESTAKE PARTNERS SECTION 23
 MINE MAP SHOWING MF COUPLED PHONE LINE RX
 LOCATIONS (MF COUPLED PROBE AT TX LOCATION
 IN WAGNER DRIFT)

SCALE: 1 INCH = 200 FEET

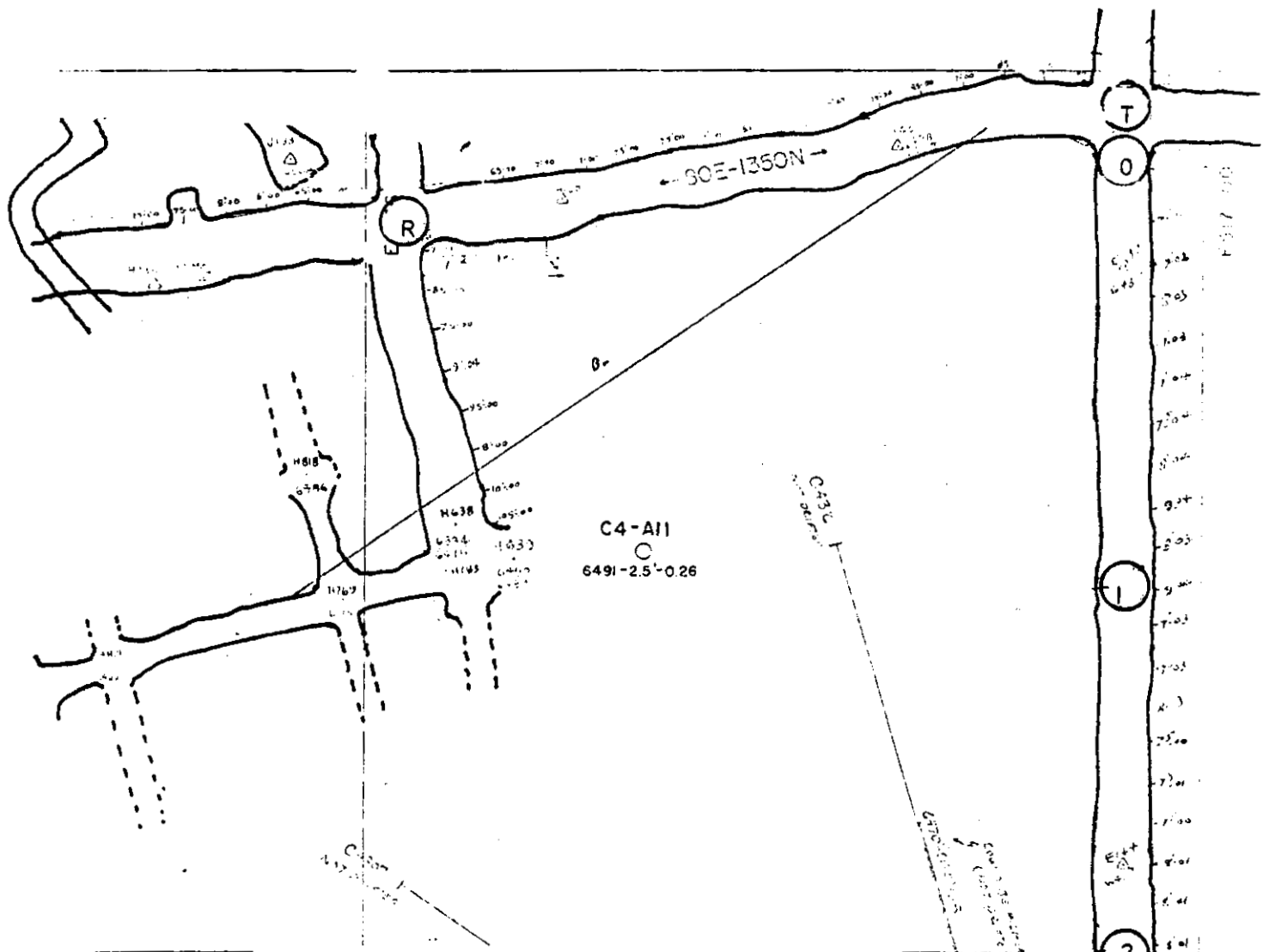
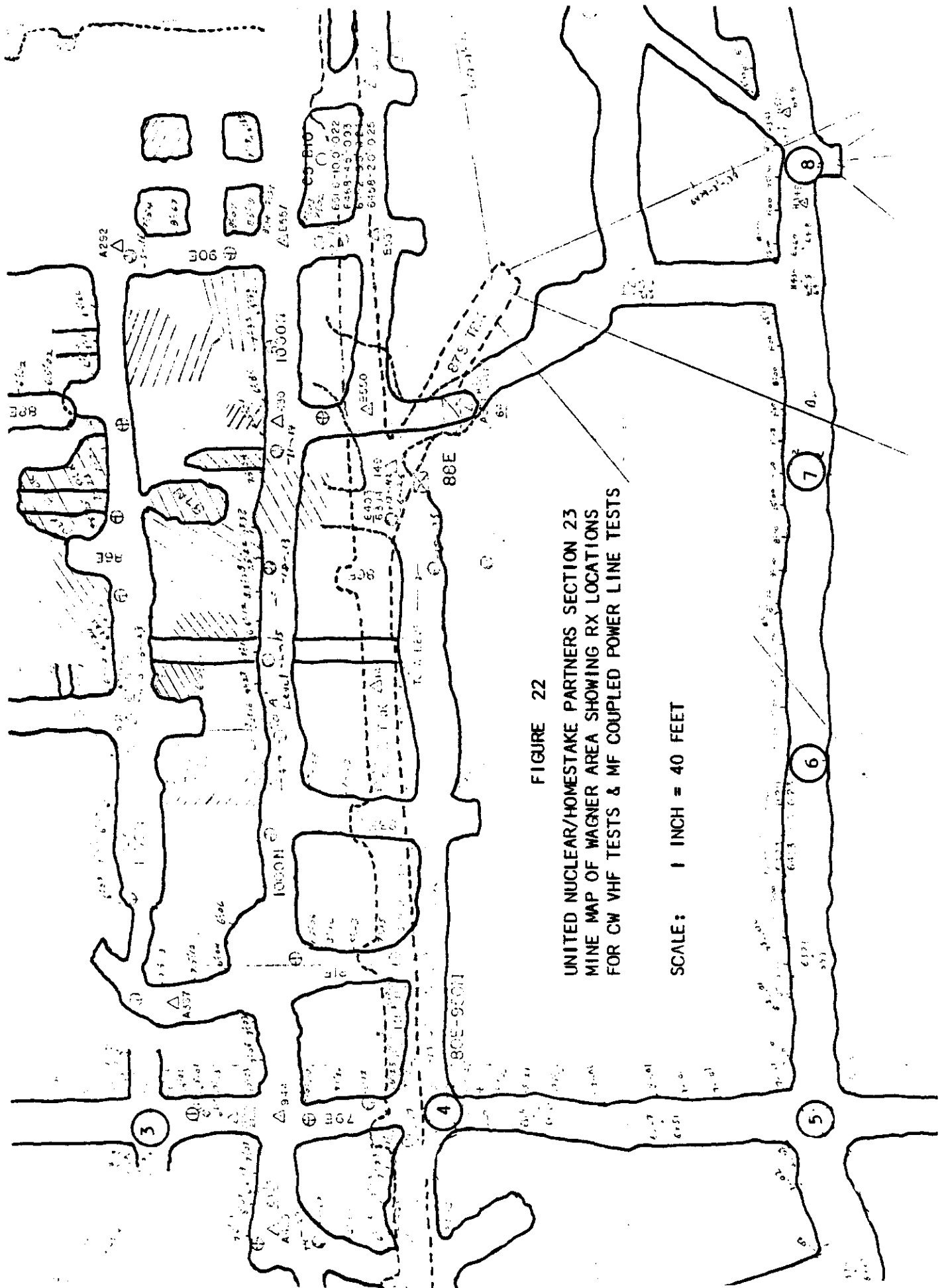

FIGURE 21

UNITED NUCLEAR/HOMESTAKE PARTNERS SECTION 23
 MINE MAP OF WAGNER AREA SHOWING PRINCIPAL
 SWEEP FREQUENCY TX & RX LOCATIONS, PLUS RX
 LOCATIONS FOR CW VHF TESTS & MF COUPLED
 POWER LINE TESTS

SCALE: 1 INCH = 40 FEET





UNITED NUCLEAR/HOMESTAKE PARTNERS SECTION 23
 MINE MAP OF WAGNER AREA SHOWING RX LOCATIONS
 FOR CW VHF TESTS & MF COUPLED POWER LINE TESTS

SCALE: 1 INCH = 40 FEET

Second Day Tests 11-29-80

Testing the second day consisted of conducting all CW tests, with the exception of the microwave tests.

Third Day Tests 11-30-80

The third day of testing consisted of conducting the microwave tests.

The swept-frequency tests were conducted along an approximate 180-foot throw in the presence of a 480 VAC line and a water line strapped to a lathe fence which was on the roof and extended down the sides of each rib comprising three overlapping sections in cross section running along the drift. Detailed profiles of the swept-frequency range geometry, drift cross sectional geometries and conductor topologies are illustrated in Figure 23.

3.2.3 KERR-MCGEE CHEMICAL CORP. HOBBS POTASH FACILITY MINE

First Day Tests 12-9-80

The first day of testing consisted solely of swept frequency measurements. The transmitting signal sources were located in Area 140 at breakthrough 3 of Room 245 (see Figure 24). Breakthrough 3 has been extended 800' and will be an active mining section when the mining operation retreats back to that point in several years. The "back" was approximately seven feet at the breakthrough intersection, but reduced to about 65" after the second breakthrough. Room 245 was observed to be free of conductors except for a low voltage (110 VAC) power cable and a pair of conveyor belt pinch wires which ran along the Northern wall and center of breakthrough #3. The pinch wires were approximately 20AWG bare steel wires separated by about four inches and mounted on insulated standoffs from the room "back". The pinch wires were observed to have open-ended terminations and ended before the fourth breakthrough of the room. The small power cable was observed to leave the room at the second breakthrough (between the first and second measurement sites) and its termination is unknown to the author. The first test site was selected mid-room and about 150' feet from the transmitting site.

The swept-frequency tests were all antenna-excited except for one MF test where the Stoddard current probe was placed around the low voltage power cable at the transmit site in breakthrough #3.

Second Day Tests 12-10-80

The second day of testing began with a measurement of continuous

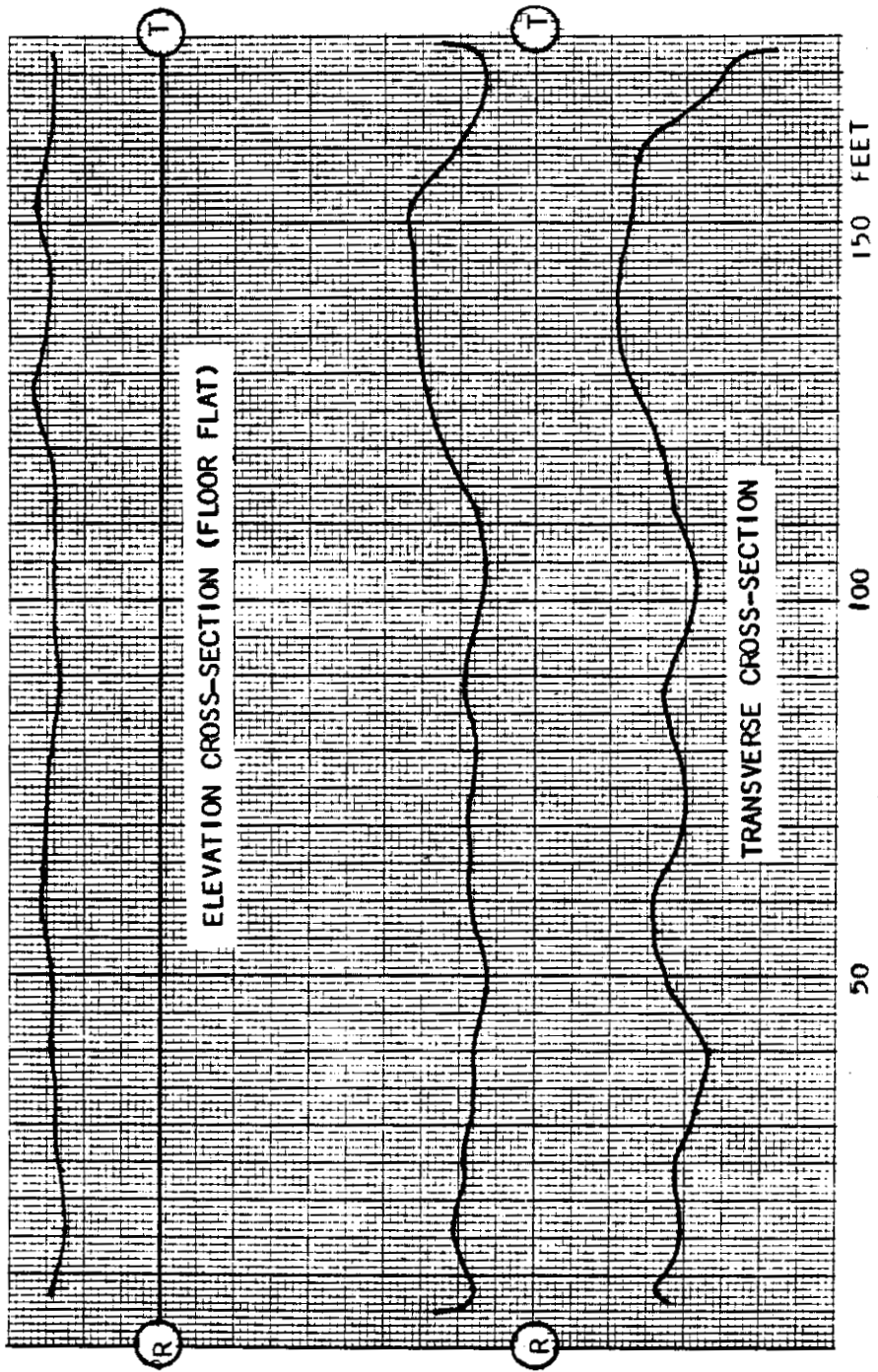

EACH SMALL SQUARE IS 0.5 FEET

FIGURE 23
 UNITED NUCLEAR/HOMESTAKE PARTNERS SECTION 2B
 MINE WAGNER DRIFT CROSS-SECTION BETWEEN
 PRIMARY SWEEP FREQUENCY TX AND RX LOCATIONS,
 FLOOR ASSUMED TO BE FLAT

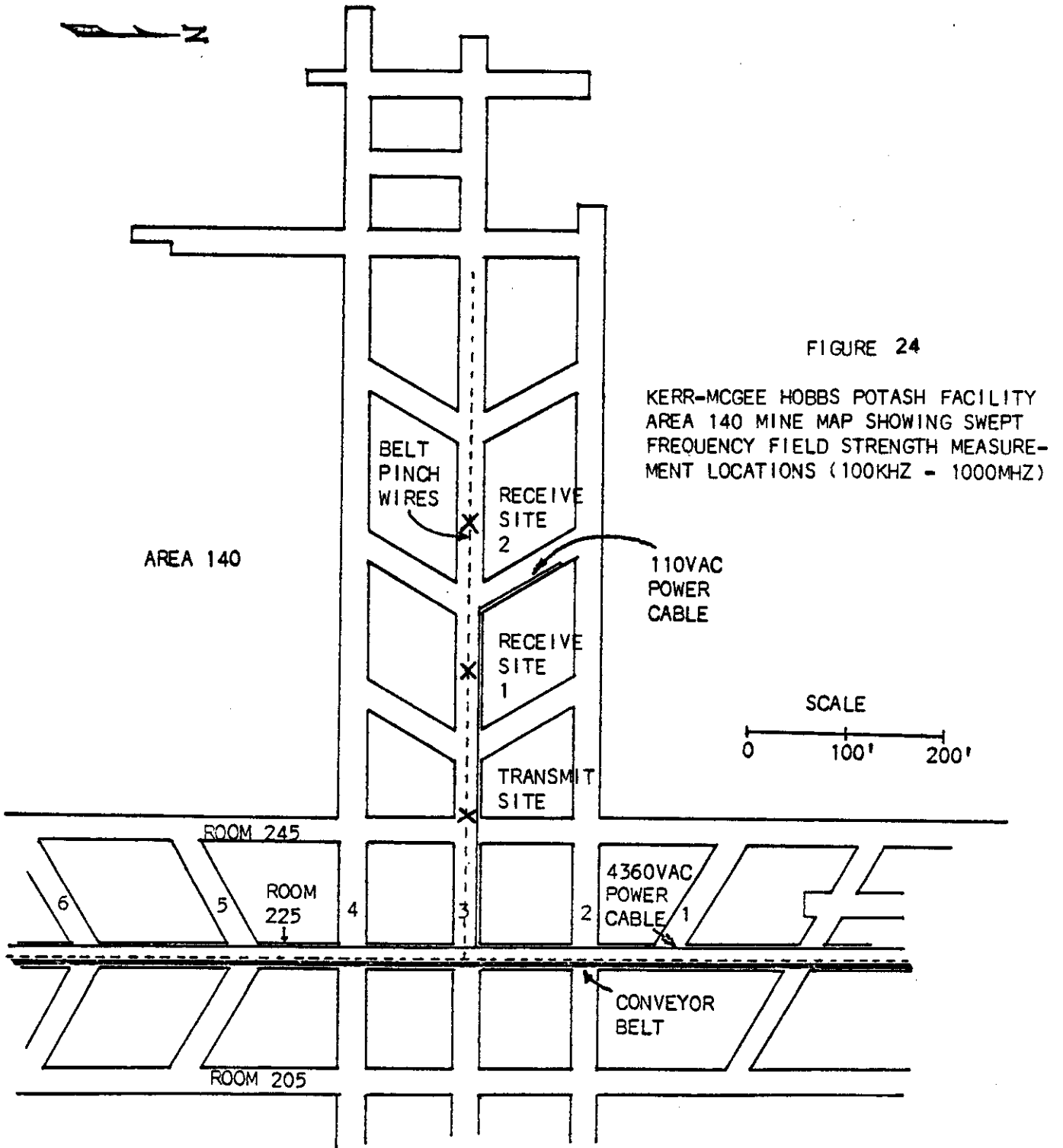

FIGURE 24

KERR-MCGEE HOBBS POTASH FACILITY
 AREA 140 MINE MAP SHOWING SWEEPED
 FREQUENCY FIELD STRENGTH MEASURE-
 MENT LOCATIONS (100KHZ - 1000MHZ)

wave signal propagation at medium frequencies in the same location of Area 140 as the first day tests (see Figure 25). Signals were transmitted at 250KHZ, 650KHZ and 950KHZ and measured as a function of distance and antenna orientation to the end of breakthrough #3. Next, a test to evaluate the UHF waveguide propagation mode was conducted in room 225 along the conveyor belt route as shown in Figure 26). The transmitter was set up near the center of the room with the antenna oriented to excite the horizontally polarized propagation mode. Field strength measurements (with a horizontally polarized receiving antenna) were then conducted at two frequencies (650MHZ and 900MHZ) as a function of distance from the transmitter site along room 225.

Later in the day, due to the generous cooperation of the mine in providing a "scooter" to the measurement team, a test to determine the extent of carrier coupled signals along the mine's primary conductors was conducted. The test consisted of locating a transmitting loop antenna at breakthrough #3 of room 225 (the conveyor belt room) in close proximity to conductors located along the West wall of the room, and conducting field strength measurements of the transmitted signal along the conductor routes in both directions from breakthrough #3. The transmitter was excited with a 650KHZ signal, which had been found to be in the optimal coupling frequency range in the previous tests. The test sites are shown in Figure 27. Test measurements were conducted with the receiving antenna in close proximity to any conductors within reach (approximately 0.6 meters). Conductors were in close proximity in all measurements except at points 14, 15, 16, 18, 19 and 20.

Third Day Tests 12-11-80

A 10 GHZ transmitter was placed in room #26 West near breakthrough #12 (see Figure 27). Line of sight field strength measurements were made as a function of distance along the room (in a Westernly direction). The measurement area consisted of a low (58") back with smooth room surfaces and a West to East grade of 3%. A depolarization test was also conducted to measure the ability of a reflector to achieve its theoretical cross-sectional gain in the beam collimation region when acting as a 45 degree reflector. The tests were concluded at breakthrough #14, because no detectable signal was located at breakthrough #15. The grade of the floor apparently resulted in enough offset in the beam projection so that a line of sight transmission path did not exist.

3.2.4 AMAX LEAD CO. OF MISSOURI BUICK MINE

The mine testing was all performed in the lower level tracked haulage drift in the North mine. A summary of the testing follows:

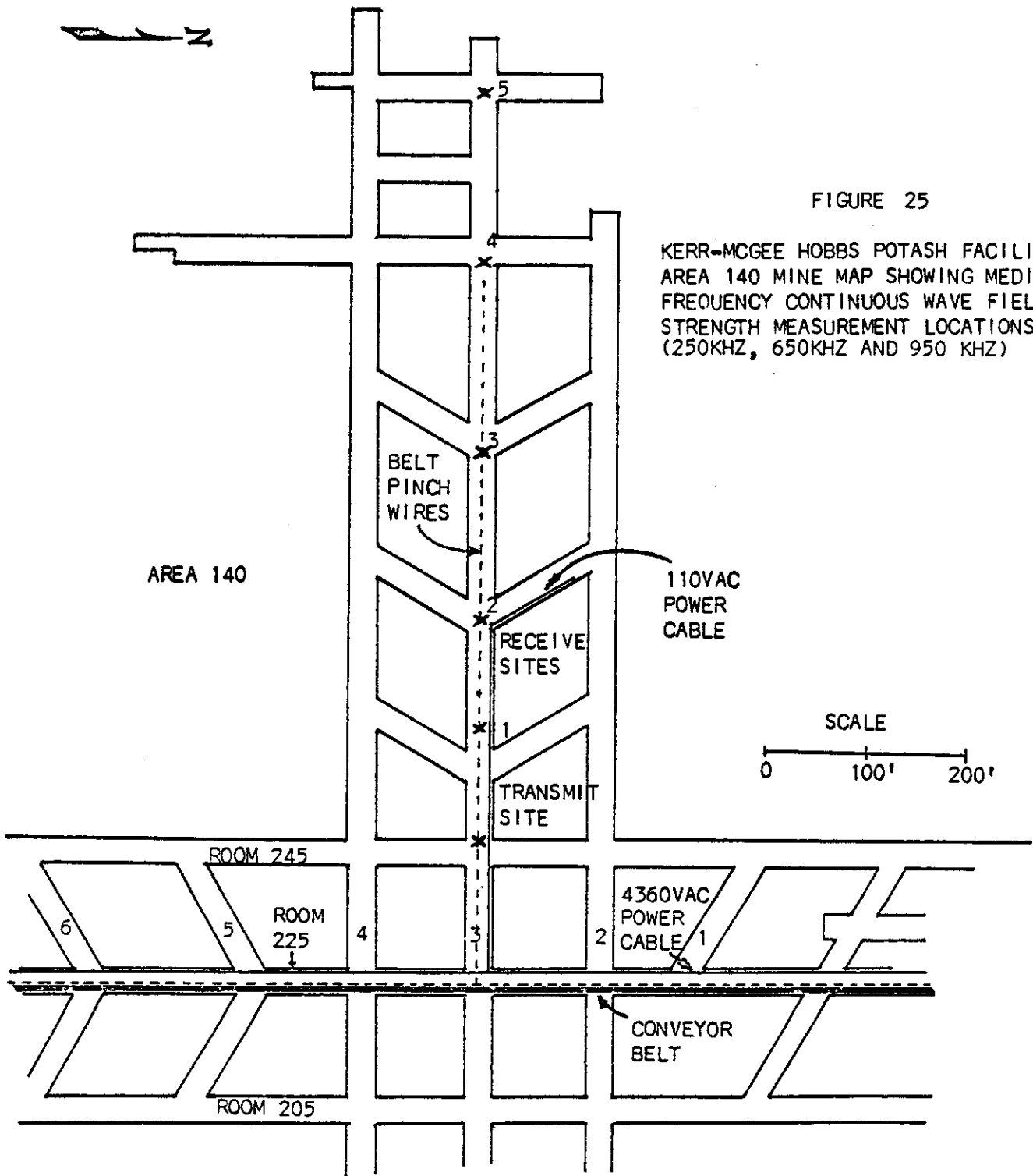

FIGURE 25

KERR-MCGEE HOBBS POTASH FACILITY
 AREA 140 MINE MAP SHOWING MEDIUM
 FREQUENCY CONTINUOUS WAVE FIELD
 STRENGTH MEASUREMENT LOCATIONS
 (250KHZ, 650KHZ AND 950 KHZ)

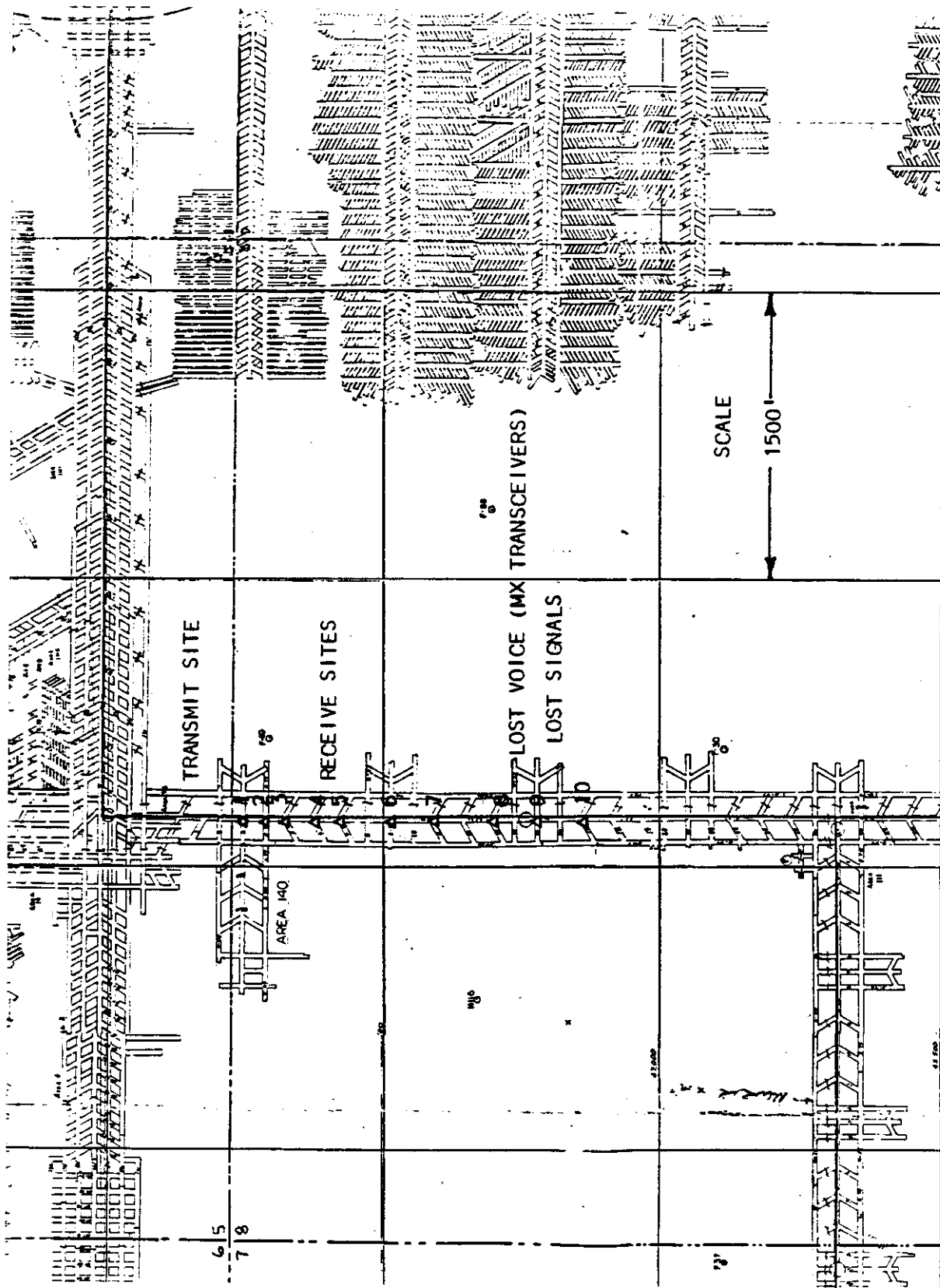

FIGURE 26

KERR-MCGEE HOBBS POTASH FACILITY AREA 140
ROOM 225 MINE MAP SHOWING UHF CONTINUOUS WAVE
FIELD STRENGTH MEASUREMENT LOCATIONS (600MHZ
AND 900MHZ)

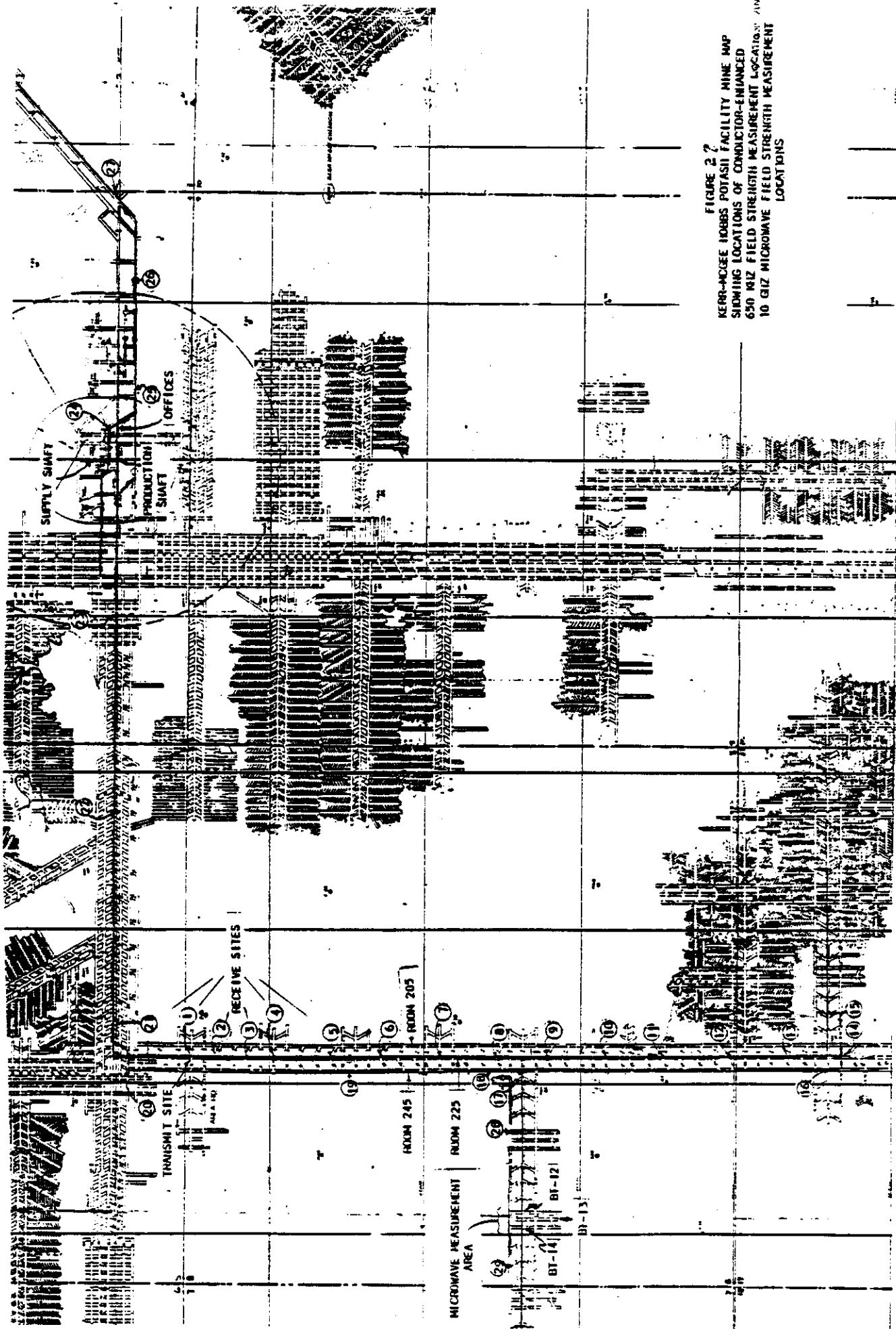

FIGURE 2
 KERR-MCGEE HOBBS POTASH FACILITY MINE MAP
 SHOWING LOCATIONS OF CONDUCTOR-ENHANCED
 650 MHz FIELD STRENGTH MEASUREMENT LOCATIONS AND
 10 GIZ MICROWAVE FIELD STRENGTH MEASUREMENT
 LOCATIONS

First Day Tests 2-3-81

Swept frequency tests over the MF, HF, VHF and UHF bands were performed with the transmitter located at the North mine Northeast/Northwest Y. All of the tests were performed with the receiving location at the 064 ore pass, 390 feet away from the transmitter. MF and HF tests were repeated at the 049 ore pass 1290 feet away from the transmitter. These test locations are illustrated on the mine maps of Figures 28 and 29.

Second Day Tests 2-4-81

Demonstration CW tests were performed using the Collins USBM prototype MF radios with the received field strength measured at each location using the Singer NM-25 field strength meter. The base station was located in the foreman's shack near the mine center. The base station transmitter was loop coupled successively into the pager phone line and into the dedicated wire which had previously been installed for adapted carrier phone tests. Voice communication and measurable field strengths were determined at a sequence of locations corresponding to the ore passes and the Y out as far as station 141. The test locations are depicted on the mine maps of Figures 28 and 29.

Third Day Tests 2-5-81

Swept frequency tests were performed over the MF band only using the low frequency 7L5 spectrum analyzer. The transmitter was set up in the foreman's shack near the mine center and was loop-coupled into the dedicated wire. Receive signal oscillographs were taken at the same ore pass stations used for the previous days testing.

The first days' MF/HF testing was found to be unrepresentative of the the general mine characteristics determined in later tests due to anomolies in the phonenumber/dedicated wire and in the AC power cables, taken as monofilar conductors, in the region of the Y. The rapid signal attenuation with increasing frequency in the MF band was first correctly observed during this testing, which initially indicated that the lower MF frequencies were optimum. The swept frequency data was too dilute to permit impedance characterization of the monofilar line structure near the Y.

During the Thursday swept frequency tests, a spectrum analyzer malfunction made the oscillographs unusable for reproduction in this report; consequently, they are not shown. The data reduced from these oscillographs is given in total.

In the vicinity of the Y, the principal return path for the phone line

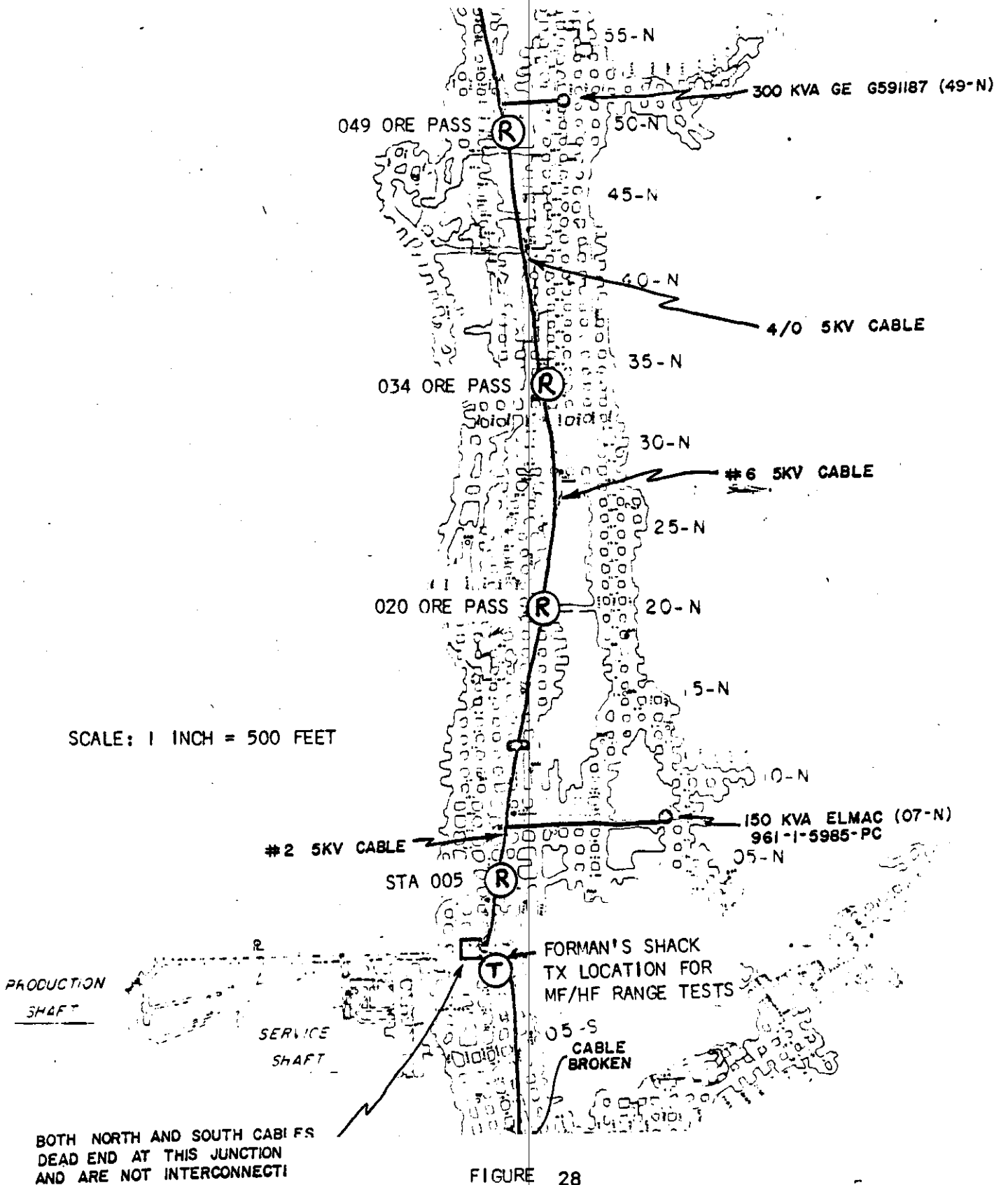

FIGURE 28

MAP OF NORTH MINE LEG OF AMAX BUICK MINE
 SHOWING TRANSMIT AND RECEIVE LOCATIONS
 USED DURING MEASUREMENTS WITH TRANSMIT
 LOCATION FOR CW & SWEEP RANGE TESTS SHOWN

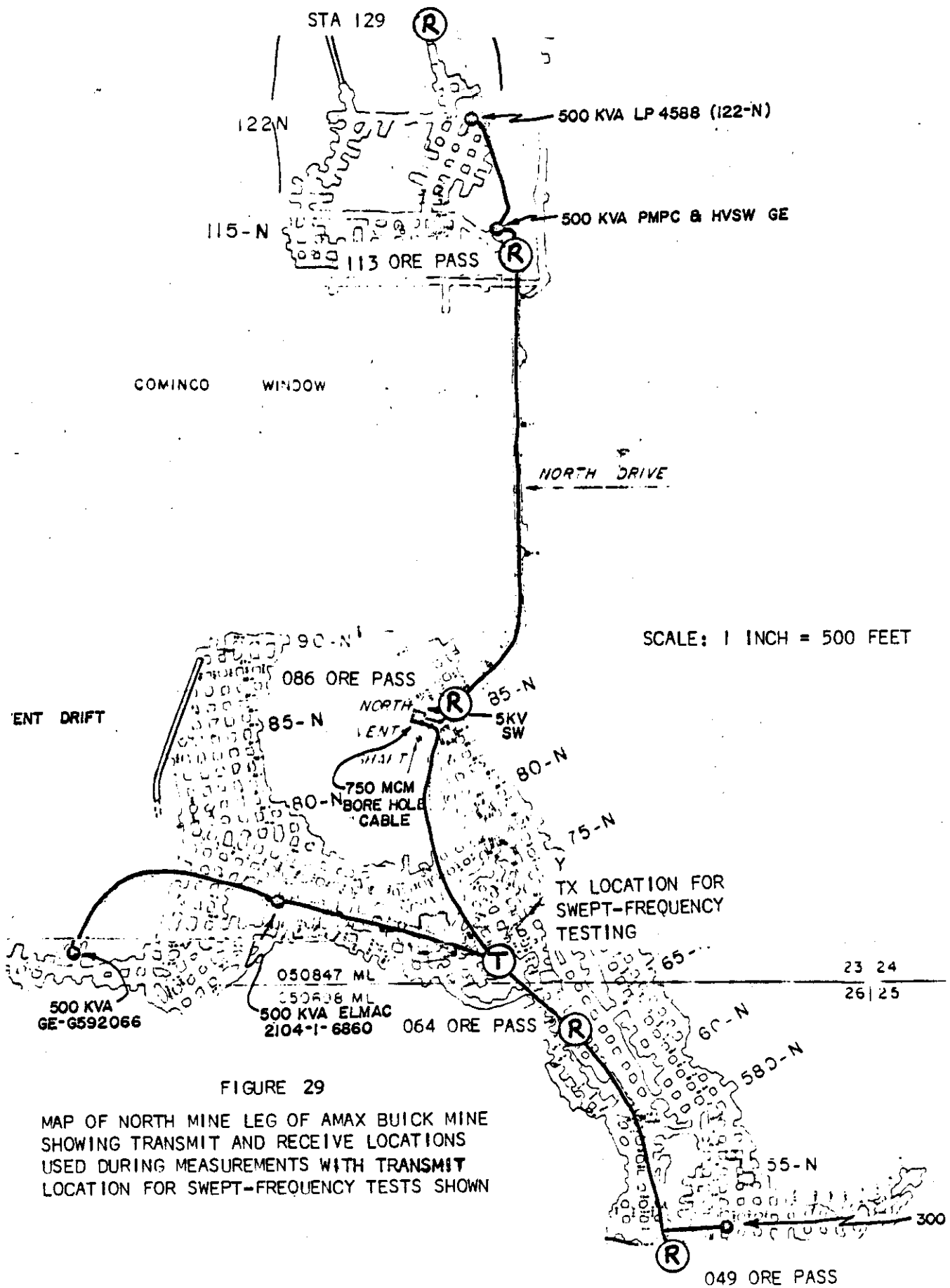

FIGURE 29

MAP OF NORTH MINE LEG OF AMAX BUICK MINE
 SHOWING TRANSMIT AND RECEIVE LOCATIONS
 USED DURING MEASUREMENTS WITH TRANSMIT
 LOCATION FOR SWEEP-FREQUENCY TESTS SHOWN

and dedicated wire (ostensibly acting as a common conductor) was the power cable bundle some four feet away. The field fall-off law was determined in this region (illustrated in Figure 6) with the range exponent determined to be 1.26.

3.2.5 MAGMA COPPER COMPANY SAN MANUEL MINE

All testing was conducted on the 2375 level, which is illustrated in Figure 30 with all the test locations on the Measurement Traverse. The drift cross section in the long haulage runs is a combination of timber ladder drift and concrete drift construction (both shown in Figure 31).

First Day Tests 3-31-81

Swept-frequency tests over the MF, HF, VHF and UHF bands were performed on the car-cleaner track. This drift contained essentially no conductors other than the track. The transmit location was set up in a timbered section of the drift. The receive location was set up 243 feet away in a concrete drift section. MF and HF data was taken for all three principal polarizations of the loop antennas. The horizontal magnetic dipole (HMD) orientations were set up in the drift center with the antenna 1.1 meters above the track. The transmit vertical magnetic dipole (VMD) orientation loop plane was positioned 1 foot (0.3 meters) above the rails. This geometry is illustrated in Figure 32. The received VMD was alternately positioned 1 foot, 4 feet and 8 feet above the rails.

The normal deployment of the VHF and UHF antennas in both vertical and horizontal polarizations was made in the drift center. No signal was received at VHF in the first location, so the receiving location was repositioned in a timbered drift section 111 feet from the transmitter.

A prototype MF radio was installed on a trolley-operated locomotive for long-term qualitative testing by mine personnel in comparison with existing carrier phone equipment. This radio employed a 145 KHz passband filter to minimize receiver desensitization.

Second Day Tests 4-1-81

A prototype base station MF radio was set up in the locomotive machine shop radio shack and another prototype radio with a 1 uV sensitivity and a 145 KHz passband filter was set up on a battery powered locomotive with a prototype vehicular antenna. The spectrum analyzer was set up in a man car behind the locomotive to permit quantitative signal and noise measurements on the base-vehicle linkage. A retuned Collins portable antenna was used with the spectrum analyzer. Talking tests were conducted around the loop traverse via panel 17, as

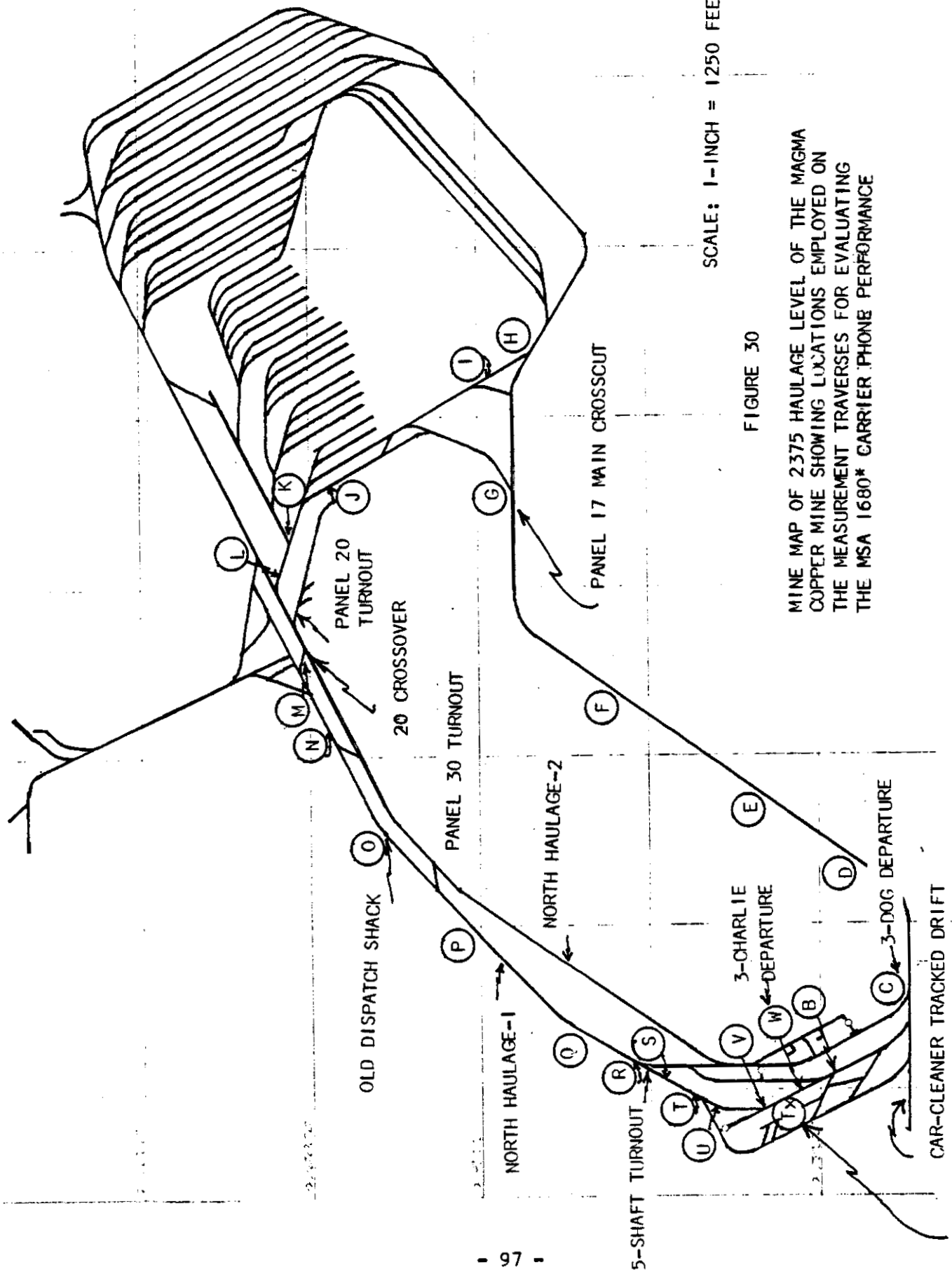

FIGURE 30

MINE MAP OF 2375 HAULAGE LEVEL OF THE MAGMA COPPER MINE SHOWING LOCATIONS EMPLOYED ON THE MEASUREMENT TRAVERSES FOR EVALUATING THE MSA 1680* CARRIER PHONE PERFORMANCE

*Reference to specific brands, equipment, or trade names in this report is made to facilitate understanding and does not imply endorsement by the Bureau of Mines

FIGURE 31

DRIFT CROSS-SECTIONAL GEOMETRIES ENCOUNTERED DURING SWEEP-FREQUENCY MEASUREMENTS IN THE MAGMA COPPER CO. SAN MANUEL MINE CAR-CLEANER DRIFT

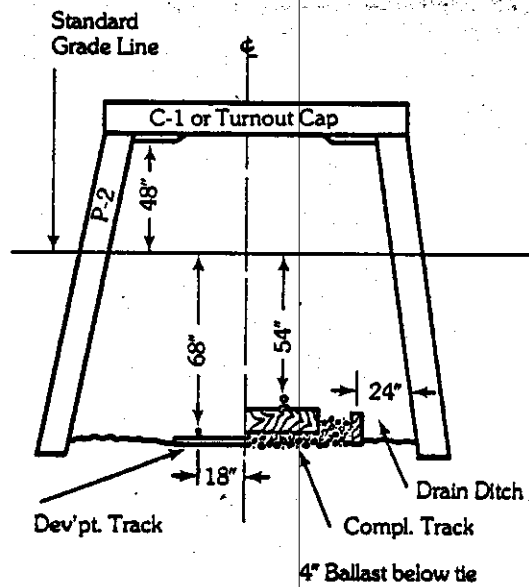

TRANSMIT LOCATION CROSS-SECTION FOR ALL FREQUENCY RANGES AND RECEIVE LOCATION CROSS-SECTION FOR VHF MEASUREMENTS

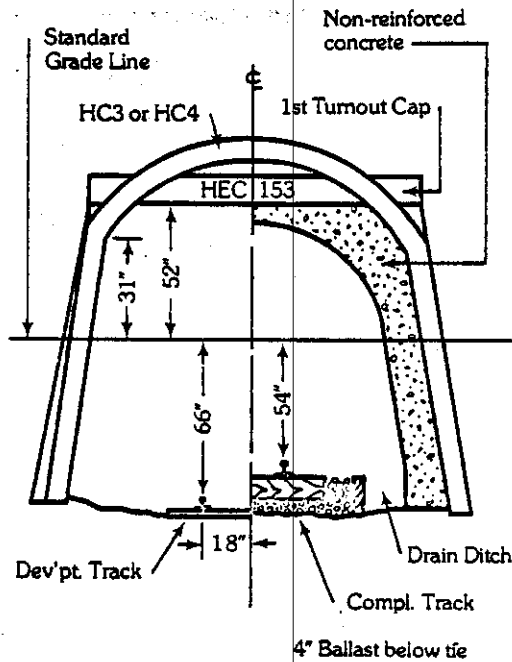

RECEIVE LOCATION CROSS-SECTION FOR ALL FREQUENCY RANGES EXCEPT VHF

FIGURE 32
TRACK COUPLING GEOMETRY FOR SWEEP-FREQUENCY
MEASUREMENTS IN MAGMA COPPER CO. SAN MANUEL
MINE

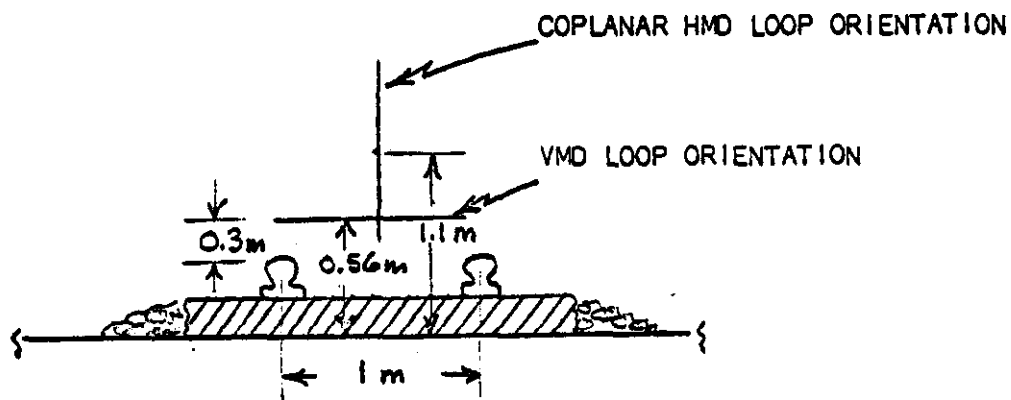

illustrated on the mine map of Figure 30. Quantitative tests were performed at the test locations listed in Table 5.

Third Day Tests 4-2-81

The Collins 0.2 uV-front-end prototype base transceiver and the vehicular radio were set to 520 KHz, similar to the preceding day, except that a vehicular radio with a 90 uV sensitivity was used without a passband filter. The vehicular antenna tuning was changed with an interchangeable 520 KHz head replacing the 145 KHz head used on Wednesday. This time, the spectrum analyzer was set up in the radio shack to permit quantitative testing on the vehicle-base linkage. The spectrum analyzer was coupled with a current probe to one of the coaxial leads feeding the Collins base station transceiver. The fixed location of the spectrum analyzer permitted a more detailed assessment of signal levels than did its usage on the man car the previous day. Voice tests were again performed around the panel 17 loop traverse, and quantitative tests were performed at the test locations given in Table 5.

3.2.6 HECLA MINING CO. CON-SIL MINE

The in mine testing was performed on the 3000-level except for radio "voice" tests in the cage and near the 2500 and 4000-level shaft stations. Due to substantial cooperation from the mine, 5-6 hours were available "on station" each day for tests, and all of the tests were completed in 2 days rather than the allotted 3 days. A chronological summary of the testing follows.

First Day Tests 6-2-81

Swept-frequency tests on the MF, HF, UHF and VHF bands were conducted in the 3000-level North Crosscut with the transmit set up near the shaft station in the pipe shop toward the South side of the mine. All data was taken on a 429 foot path with the receiving locations just in front of the first active set of air doors. The VHF and UHF data was repeated at a closer range of 195 feet with the receiving location at the first cut to the left in the outby direction. The antenna orientations and locations employed in the drift cross section geometry are given in Figures 33 and 34. The swept-frequency test locations are shown in Figure 35.

Second Day Tests 6-3-81

All range tests at MF frequencies and the X-band test were conducted on the second day. The locations for the MF range tests are illustrated in the mine map of Figure 36. Specific ranges from the fixed transmitting location to these test locations are given in Table

TABLE 5
 DISTANCES TO LOCATIONS ALONG THE MEASUREMENT TRAVERSE
 ON THE 2375 HAULAGE LEVEL

LOCATION	LOOP DISTANCES STARTING ON SOUTH HAULAGE (FEET)	LOOP DISTANCES STARTING ON NORTH HAULAGE (FEET)
B	480	13,676
C	1,180	12,976
D	2,180	11,976
E	2,788	11,368
F	3,880	10,276
G	5,320	8,836
H	6,220	7,936
I	6,500	7,656
J	7,892	6,264
K1	8,124	6,032
K2	8,212	5,944
L	8,660	5,496
M	9,180	4,976
N	9,564	4,592
O	10,324	3,832
P	11,132	3,024
Q	12,124	2,032
R	12,364	1,792
S	12,524	1,632
T	12,692	1,464
U	12,892	1,264
V	13,244	912
W	13,516	640
B	13,676	480

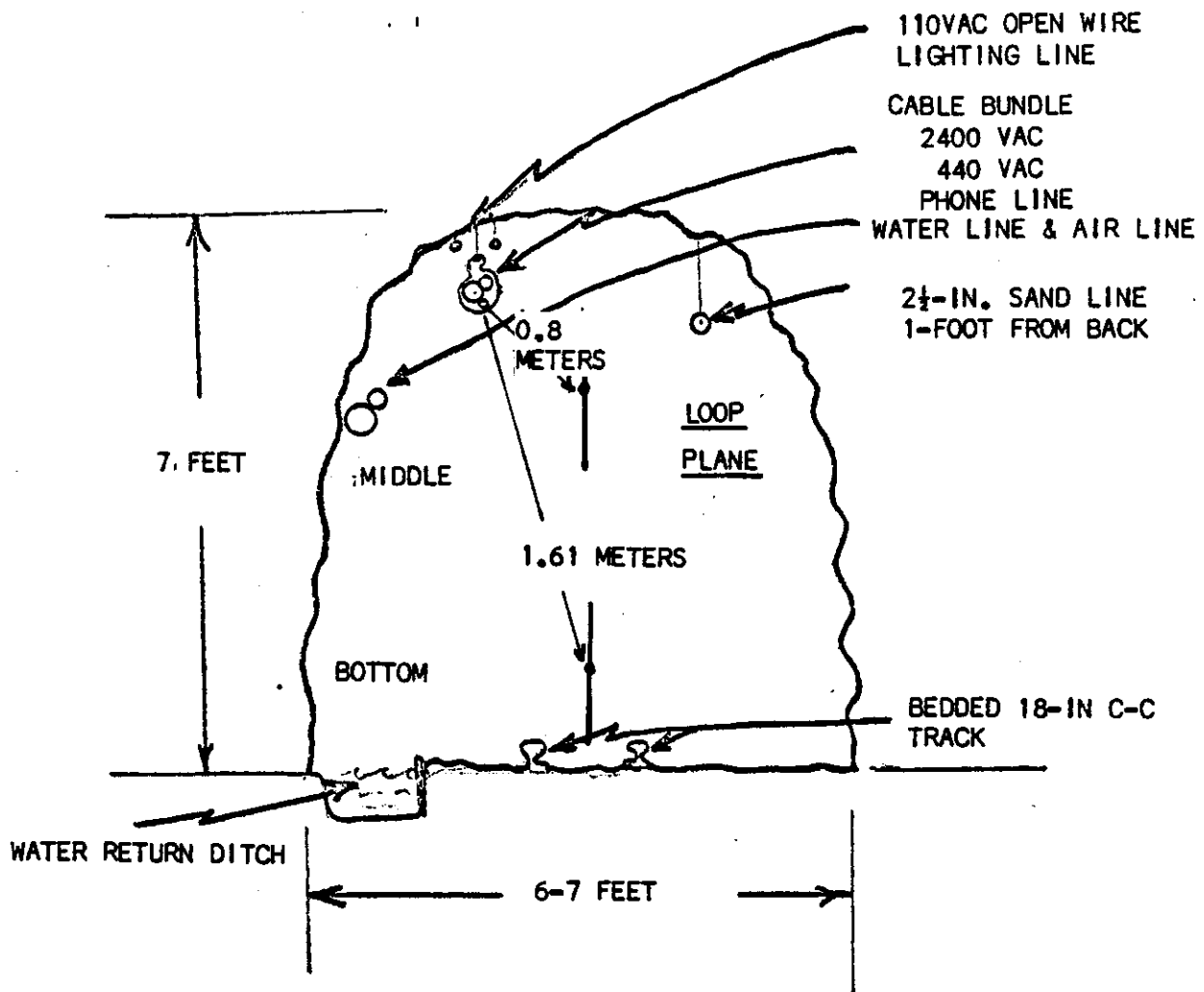

FIGURE 33
 DRIFT CROSS-SECTIONAL GEOMETRY VIEWED IN THE 1MBY
 DIRECTION SHOWING HMD TEST ANTENNA LOCATIONS
 HECLA CON-SIL MINE

MIDDLE H(DB) = I(DB) - 26.6 DB

BOTTOM H(DB) = I(DB) - 39.0 DB

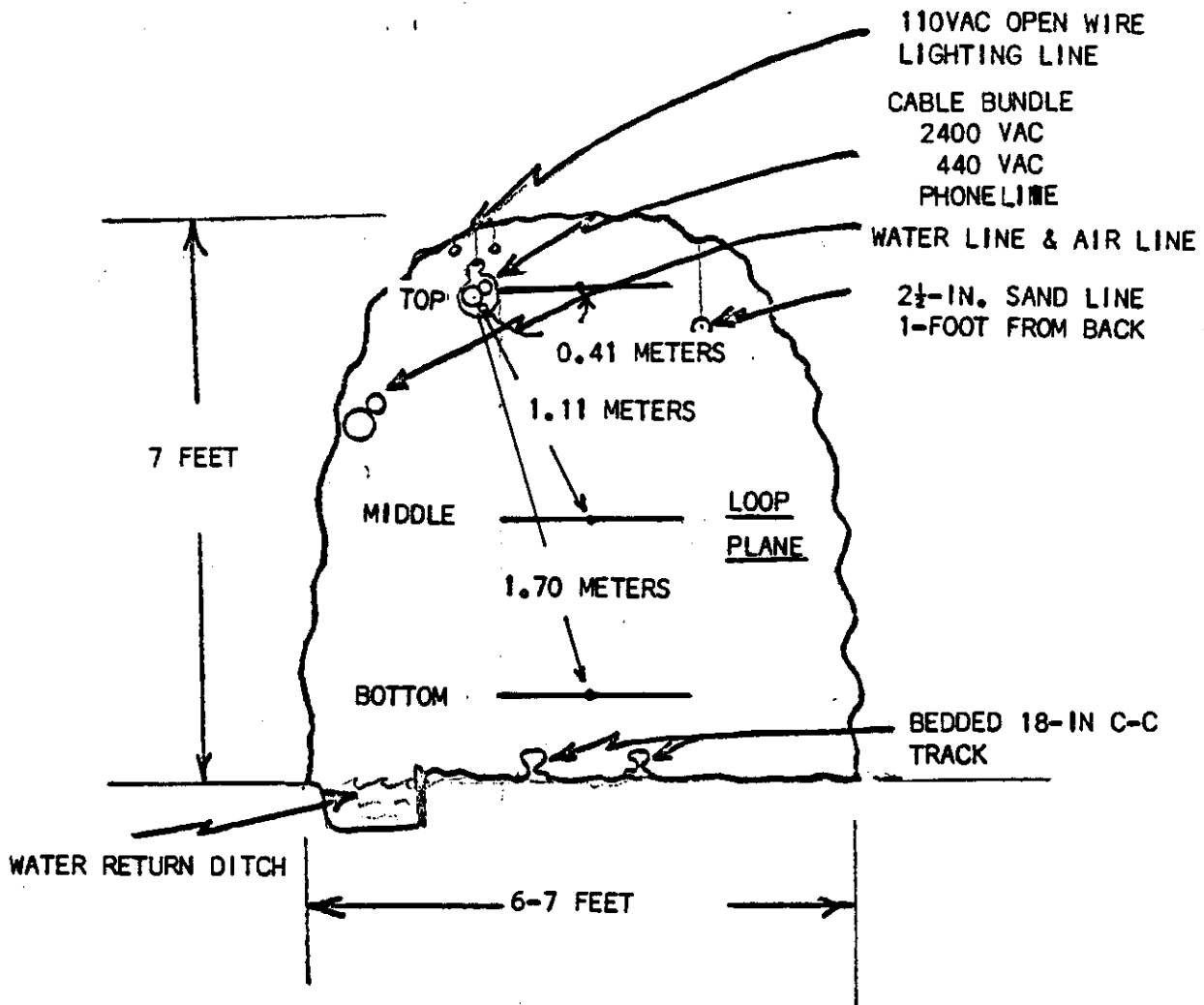
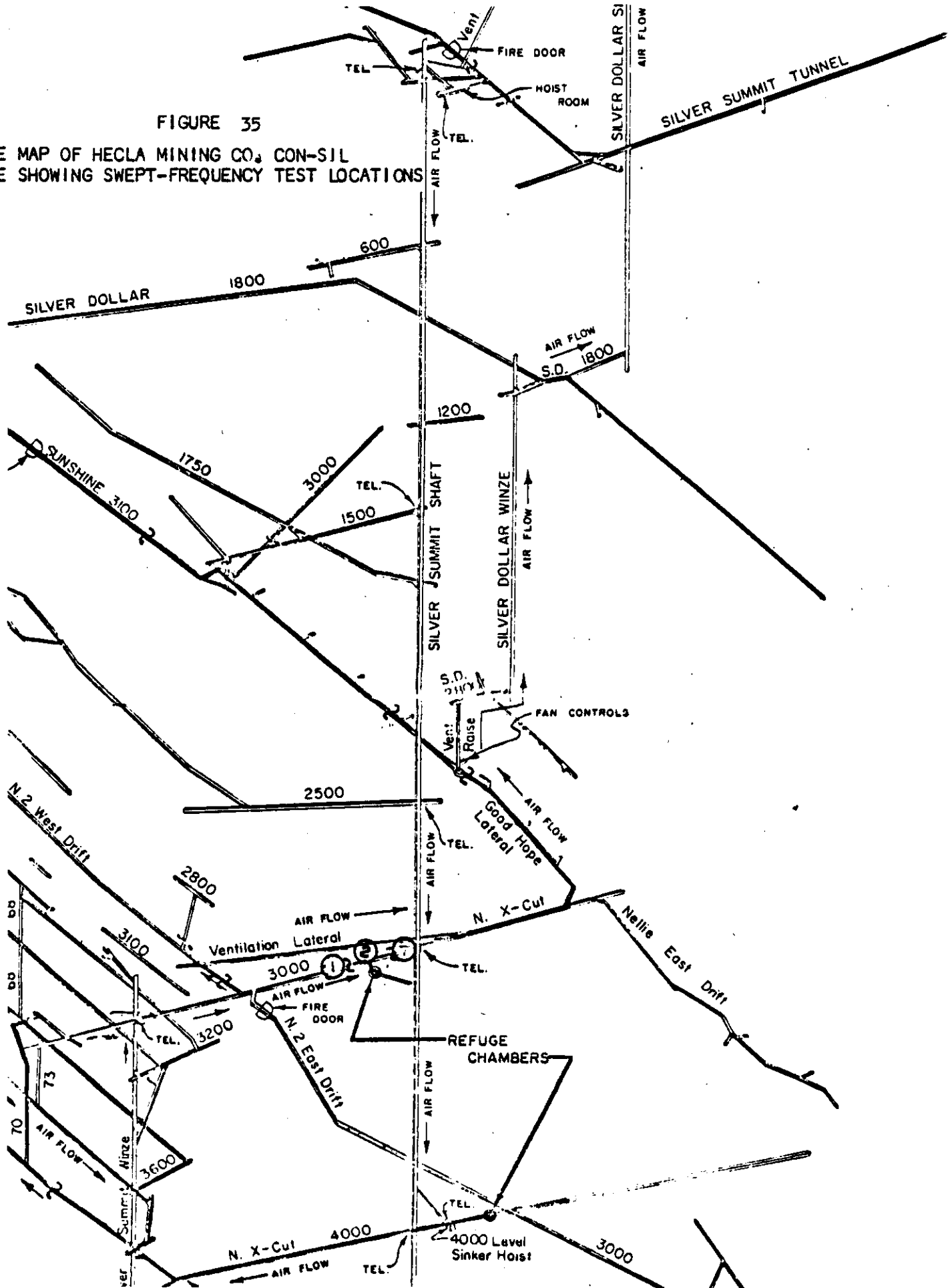

FIGURE 34
 DRIFT CROSS-SECTIONAL GEOMETRY VIEWED IN THE INBY
 DIRECTION SHOWING VMD ANTENNA LOCATIONS
 HECLA CON-SIL MINE

- TOP H(DB) = I(DB) - 13.7 DB
- MIDDLE H(DB) = I(DB) - 32.5 DB
- BOTTOM H(DB) = I(DB) - 40.0 DB

FIGURE 35
 MINE MAP OF HECLA MINING CO. CON-SIL
 MINE SHOWING SWEEP-FREQUENCY TEST LOCATIONS



6. MF range tests were performed using the 1 Watt transmit test equipment and the prototype Collins mine wireless FM portable transceivers.

The microwave test data was very inconclusive in this mine and was obtained with the transmitter located at drift center adjacent to the pipe shop with the receiver moving along the drift in the South direction. A range of only 50 feet was achieved with signal levels being insufficient for the corner reflector tests.

3.3 SYSTEM PERFORMANCE CONSIDERATIONS

Wireless transmission in a "closed" conducting drift is possible if one of the drift dimensions exceeds a half wavelength (waveguide mode) or if the radio system antennas couple in close proximity to one or more conductors (monofilar mode for a single active conductor or common-mode-excited conductor ensemble, bifilar mode for differential excitation of "pairs" of conductors in the differential mode). Above the guide cut-off frequency transmission approaches the free-space propagation constrained by the guide geometry and topology as the refractive and scattering losses diminish and as the guide wavelength decreases. At low VLF and MF frequencies, the transmission is characterized by quasi-static coupling of the loop antennas (presumed small) to conductors and/or conducting surfaces in the geometry of the drift cross-section. These low-frequency fields conform to the Laplace equation solution for this geometry and are excited by currents presumed flowing in the antennas or in the conductors by Ampere's law. The actual current coupling ratio between the antenna and these conductors is a function only of these geometric non-frequency-varying fields and the impedance of the antenna or conductors in which the "secondary" current is being induced (with performance analogous to a transformer).

Once coupled, the signal transmission along the conductors at these low frequencies is governed by the physical parameters of the transverse electromotive mode (TEM) line, monofilar or bifilar, formed by these conductors. The transmission system is analogous to any TEM transmission line with regard to the propagation constant (attenuation and phase) and the superposition of traveling TEM waves.

The transmission loss between wireless transmitting and receiving antennas is least at MF frequencies and the upper UHF frequencies with the minimum loss signal levels being nearly the same for practical portable systems. At intermediate HF, VHF and low-UHF frequencies, the transmission loss is greater because:

- the low-frequency attenuation loss of the TEM lines

TABLE 6

DISTANCES TO CW LOCATIONS ON 3000-LEVEL OF CON-SIL MINE

LOCATION		LOCATION	
1	100 FEET	A	195 FEET
2	259	B	429
3	450	C	564
4	630	D	1104
5	783	E	1150
6	963	F	1050
7	1134		
8	1530		
9	2358		
10	1000 FT. DOWN ON 4000-LEVEL		
11	500 FT. UP ON 2500-LEVEL		

increases approximately linearly with frequency with this loss becoming very great at frequencies below the waveguide cut-off frequency

- the high-frequency waveguide attenuation loss due to refraction and scattering is very great at frequencies well above the upper usable TEM frequency, this loss decreases rapidly with increasing frequency
- the low-frequency coupling is reduced with increasing frequency into the HF band because of phase cancellation in the excitation region
- the median driving point impedance levels of the TEM lines generally increases with frequency beyond the MF band which reduced the low-frequency coupling

These intermediate frequencies are of no practical utility in metal/non-metal mines. The UHF frequencies are of marginal utility in many non-rock mines having small drift cross-sections because of line-of-sight limitations, with substantial attenuation incurred at corners, unless signals are coupled via special leaky-feeder cables. During the program, UHF transmission conformed to gentle bends in the drifts, so the transmission is not strictly limited to line-of-sight applications. Microwave frequency usage is strictly line-of-sight limited, with especially large scattering losses characterizing even gentle bends due to statistical roughness of the rib and back/floor surfaces.

The above macroscopic effects were observed in all mines visited.

Particularly noteworthy results of the testing include:

- the classic waveguide cut-off frequency is of no practical consequence in wireless transmission at UHF frequencies with the transmission optimizing in the 800 MHz region and above regardless of drift size
- the upper practical MF frequency is about 1 MHz with a rapid increase in transmission losses above this frequency
- the incident received field strength (or monofilar line current) due to excitation with a transmitting antenna falls off at a rate of at least 40 dB/decade for frequencies above approximately 1 MHz

- a quasi-static coupling model for MF frequencies has been verified which accounts for conductors close to a conducting surface, and for the size and spacing of the conductors relative to the surface

The remainder of this section will be devoted to examining the mechanisms which are the most probable candidates for producing these results. As the low frequency (MF and HF) coupling into wiring is of the greatest practical importance, most of the analytical effort involves defining the coupling phenomena. The above noteworthy results are apparent in the summary MF/ UHF spectral magnetic field strength curves (equivalent magnetic field strength for the electric data) for the test system shown in Figures 37 and 38.

3.3.1 LOW-FREQUENCY COUPLING MODELS

At VLF and low-MF frequencies, the coupling fields are largely quasi-static and are definable in geometrically varying terms only. That is, given a current flowing in an exciting source loop (transmit case with respect to a radio system) or in a conductor ensemble (receive case with respect to a radio system), the forms of the electromagnetic fields are independent of frequency. The induced current in the "receiving" conductor ensemble or loop antenna increases linearly with frequency for constant exciting current and constant loop or line impedance. The form of the fields is controlled by the potential monofilar or bifilar line geometries in the drift cross-section as opposed to those associated with the loop antenna and its relative location in the drift. This effect is best visualized by considering the line (conductor ensemble) to be transmitting. The geometric dependence of the coupled current for the transmitting loop antenna can then be shown to be the same by reciprocity.

In free space, the magnetic field strength extending radially away from a line source carrying current is, by Ampere's law:

$$H = \frac{I_{line}}{2\pi r}$$

r is the range to the antenna center
in meters

with the open circuit voltage in a receiving loop being:

$$V_{oc} = \frac{\omega \mu I_{line} (NA)}{(2\pi r)}$$

N, A are the number of turns and loop area respectively.

FIGURE 37

SUMMARY OF WIRELESS TRANSMISSION MAGNETIC FIELD STRENGTH CHARACTERISTICS OBTAINED IN MINES #1, #2, AND #3; 1 WATT TRANSMIT POWER

RANGE: MINE #1 - 120 FEET
 MINE #2 - 180 FEET
 MINE #3 - 150 FEET

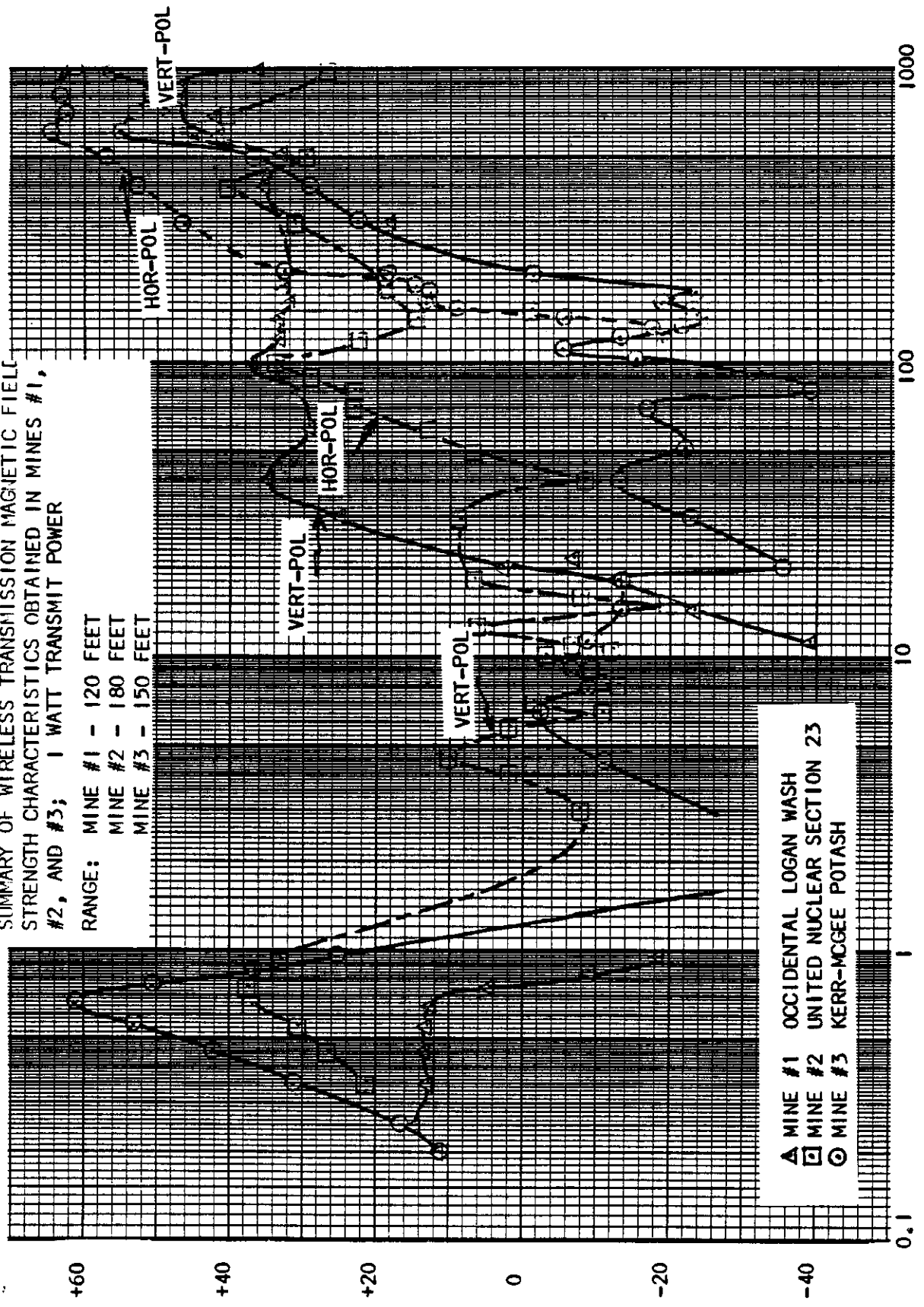

▲ MINE #1 OCCIDENTAL LOGAN WASH
 □ MINE #2 UNITED NUCLEAR SECTION 23
 ○ MINE #3 KERR-MCGEE POTASH

MAGNETIC FIELD STRENGTH IN DB ABOVE 1 MICRAMP/METER

FREQUENCY - MHZ

FIGURE 38

SUMMARY OF WIRELESS TRANSMISSION MAGNETIC FIELD STRENGTH CHARACTERISTICS OBTAINED IN MINES #4, #5, AND #6; 1 WATT TRANSMIT POWER

RANGE: MINE #4 - 390 FEET
 MINE #5 - 111 FEET (VHF)
 243 FEET (UHF, MF, AND HF)
 MINE #6 - 195 FEET (VHF, UHF)
 429 FEET (MF, HF)

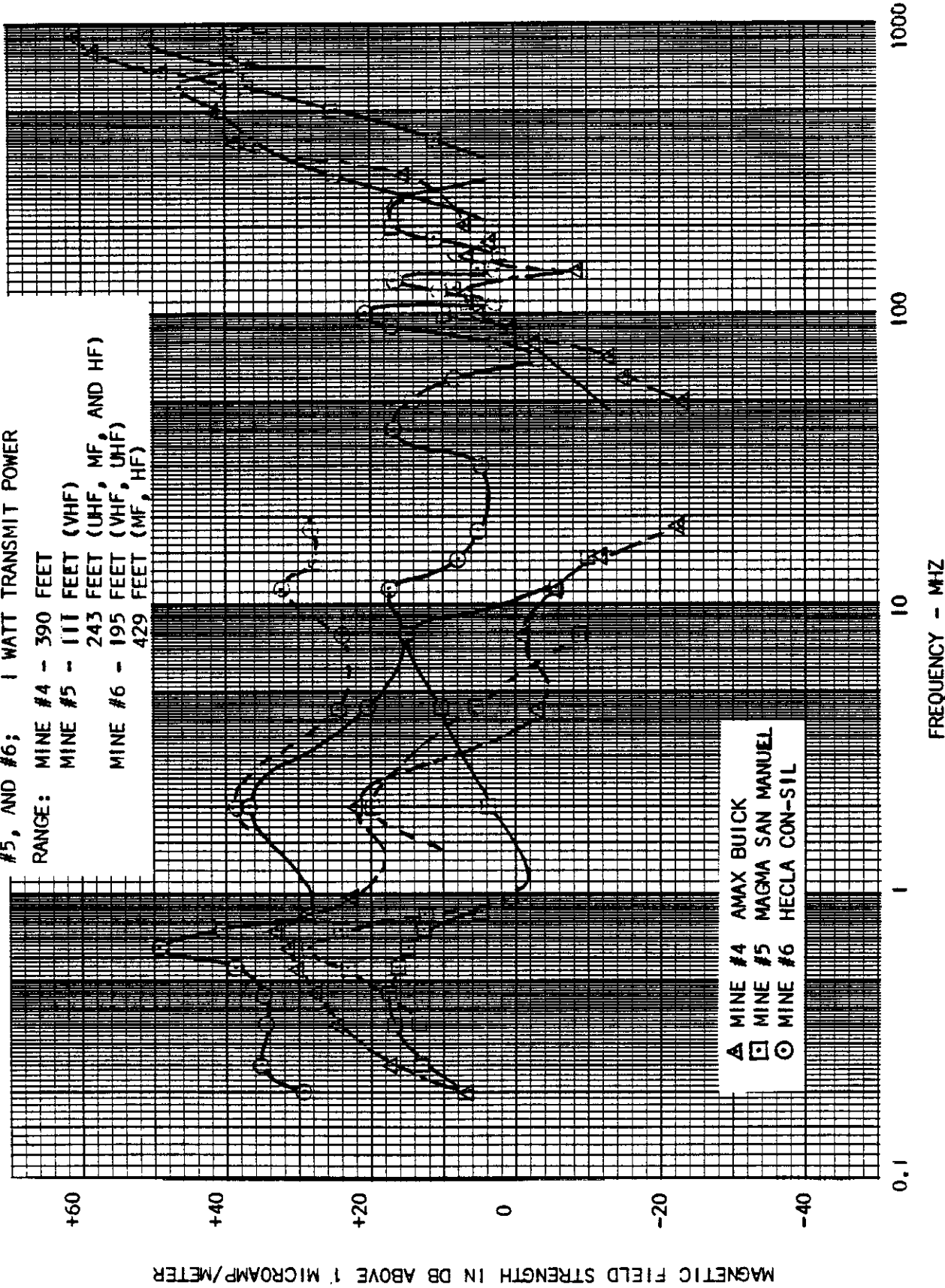

△ MINE #4 AMAX BUICK
 □ MINE #5 MAGMA SAN MANUEL
 ○ MINE #6 HECLA CON-SIL

For a tuned matched loop, the current transfer ratio is then:

$$\frac{I_{\text{loop}}}{I_{\text{line}}} = \frac{\omega \mu N A}{2R(2\pi r)} = \frac{2\pi f \times 10^{-7} N A}{R r}$$

R is the series loop circuit resistance.

For a flat matched line with a surge impedance Z_0 with a transmitting loop, the current transfer ratio by reciprocity is:

$$\frac{I_{\text{line}}}{I_{\text{loop}}} = \frac{\omega \mu N A}{4Z_0(2\pi r)} = \frac{2\pi f \times 10^{-7} N A}{2 Z_0 r}$$

This simple rather idealized quasi-static model is also a practical one for it is also appropriate for a drift of circular cross-section with a conductor ensemble at the drift center (coaxial line), and also for antenna locations near the center of a wide-spaced bifilar line formed, by a conductor near the back and a track or ground conductor near the floor. These models are illustrated in Figure 39. Note for this case that the radial distance "fall-off" law is $1/r$ as opposed to the free space induction field fall-off away from a loop of $1/r^3$.

Generally, the conductor ensemble is eccentrically located in the cross-section of a non-circular drift; often with the conductors in close proximity to one of the conducting walls. In this limit, the magnetic field strength away from an assumed transmitting line source is given by:

$$H = \frac{I_{\text{line}}}{2\pi r^2 \left[1 - \frac{(d^2 - R^2)}{r^2} \right] \sqrt{d^2 - R^2}}$$

where r, d, R are as defined in Figure 40.

Corresponding expressions for current coupling ratios are readily obtained by replacing "r" in the previous derivations with the

FIGURE 39
GEOMETRIES OF CASES FOR 1/R MAGNETIC FIELD FALL-OFF

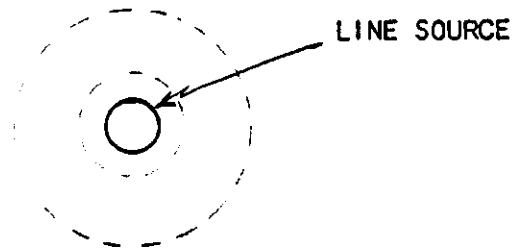

ISOLATED LINE SOURCE IN FREE SPACE

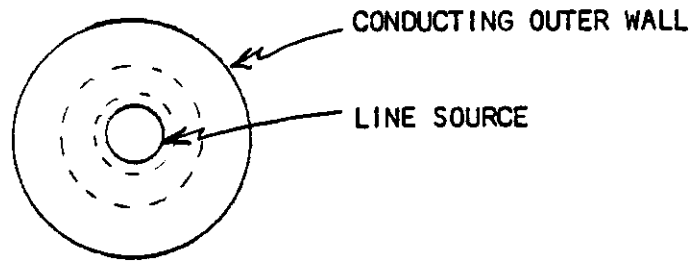

CONSTRAINED COAXIAL LINE GEOMETRY

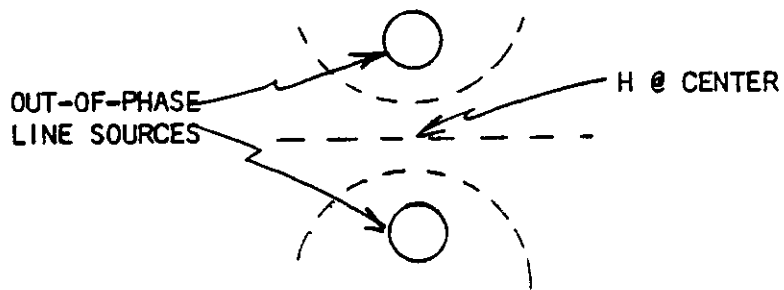

CENTER OF BIFILAR-LINE

FIGURE 40
 MONOFILAR TRACK COUPLING MODEL GEOMETRY

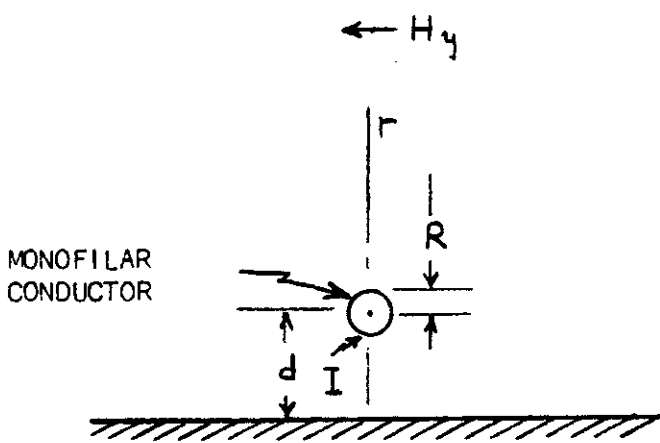

$$H_y = \frac{I}{2\pi} \left[\frac{\sqrt{d^2 - R^2}}{r^2 [1 - (d^2 - R^2)/r^2]} \right]$$

FOR CAR-CLEANER TRACK DRIFT RECEPTION:

- FOR VMD
 - 1-FOOT = 0.3 M SPACING
 - H_y (DB) = I (DB) - 17.0
 - 4-FOOT = 1.22 M SPACING
 - H_y (DB) = I (DB) - 32.5
 - 8-FOOT = 2.44 M SPACING
 - H_y (DB) = I (DB) - 43.8
- FOR HMD
 - 1.1 M SPACING
 - H_y (DB) = I (DB) - 29.2

geometric quantity in brackets. Note that the field strength diminishes for both large and small conductors at the same center spacing from the surface; a phenomenon always observed in drifts containing water, sand and air lines. This above model was validated in the Magma Copper San Manuel mine test data shown in Figure 41. Monofilar line (track) current is plotted for various test ranges away from the line and compared with computed results.

3.3.2 INTERMEDIATE FREQUENCY COUPLING & ATTENUATION

The quasi-static coupling of a loop antenna to a monofilar conductor clearly occurs over a range of distances along the conductor, as the range dependence for the coaxial line bound is $1/r$ instead of $1/r^3$ when the loop is transmitting. This coupling may be visualized as the integral along the conductor of $1/r^3$ range dependencies to discrete current elements. The geometry for this is illustrated in Figure 42. As the frequency increases the phase difference between the symmetric coupling "zones" as measured along the monofilar line (phase velocity of a traveling wave along the line) increases. Assuming that each zone individually couples to the line at a discrete "centroid" location, the two traveling waves have a cosine relationship. As the phase difference between centroid locations approaches 180 degrees, the coupling decreases approximately as $1/f$ ($1/f^2$ for a point field impinging on a receive antenna due to inductively coupled transmit excitation via the line). As the frequency is further increased, additional halfwave segments of line fall within the coupling range "window" within each zone. As these segments occupy less than the total length of the zone, the periodic coupling amplitude recovery for even numbers of segments never reaches the low frequency limit with the zonal coupling approaching a finite bound similar to a Fresnel zone diffraction effect. As a result, the approximate $1/f$ coupling fall-off occurs over a relatively wide frequency range. This coupling mechanism was verified by data taken in the AMAX mine which is given in Figure 43. This effect begins at a lower frequency for greater distances between antennas and the conductors; so, for mines with larger drift cross-sections, the fall-off appears to be more severe.

The coupling is also a function of the loop and line matched impedances. For inductive coupling appropriate for MF and low-HF frequencies, optimum performance is obtained with the minimum impedance. The driving point impedance is a function of the surge impedance Z_0 , the line termination conditions, and line losses. At intermediate frequencies and above, the driving point impedance may be considered to be essentially equal to the surge impedance of the line. At lower frequencies, the driving point impedance will vary greatly with termination conditions. In mines, the terminations are usually low impedances, so that generally the driving point impedance levels

FIGURE 41

MF/HF CHARACTERIZATION OF TRACK AS A MONOFILAR
 CONDUCTOR COMPARING COMPUTED CURRENTS AND
 CURRENTS DERIVED FROM MAGNETIC FIELD STRENGTH
 DATA - MAGMA COPPER CO. SAN MANUEL MINE -
 1- WATT TRANSMIT POWER

RANGE: VHF - 111 FEET
 UHF, MF, HF - 243 FEET

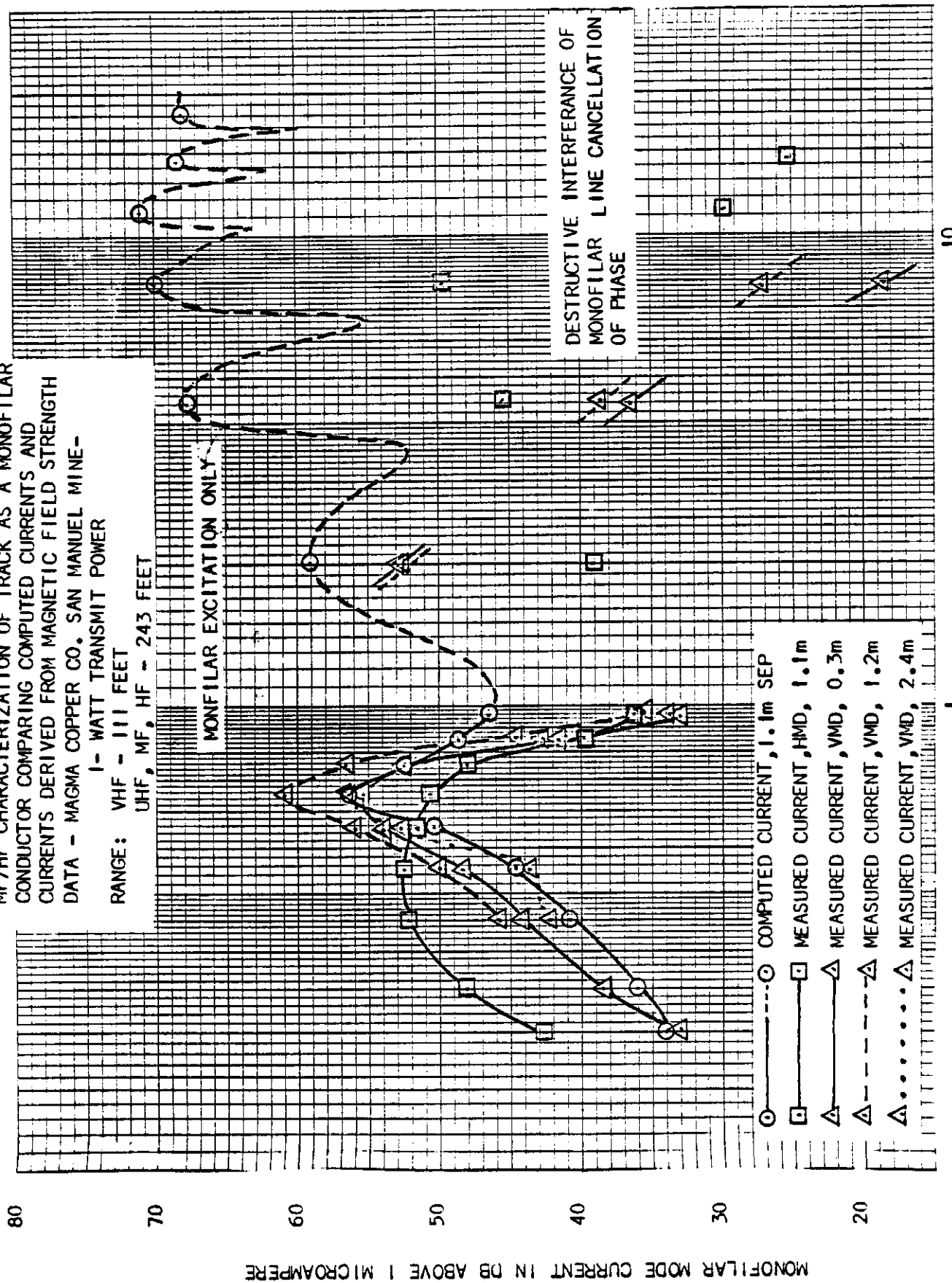

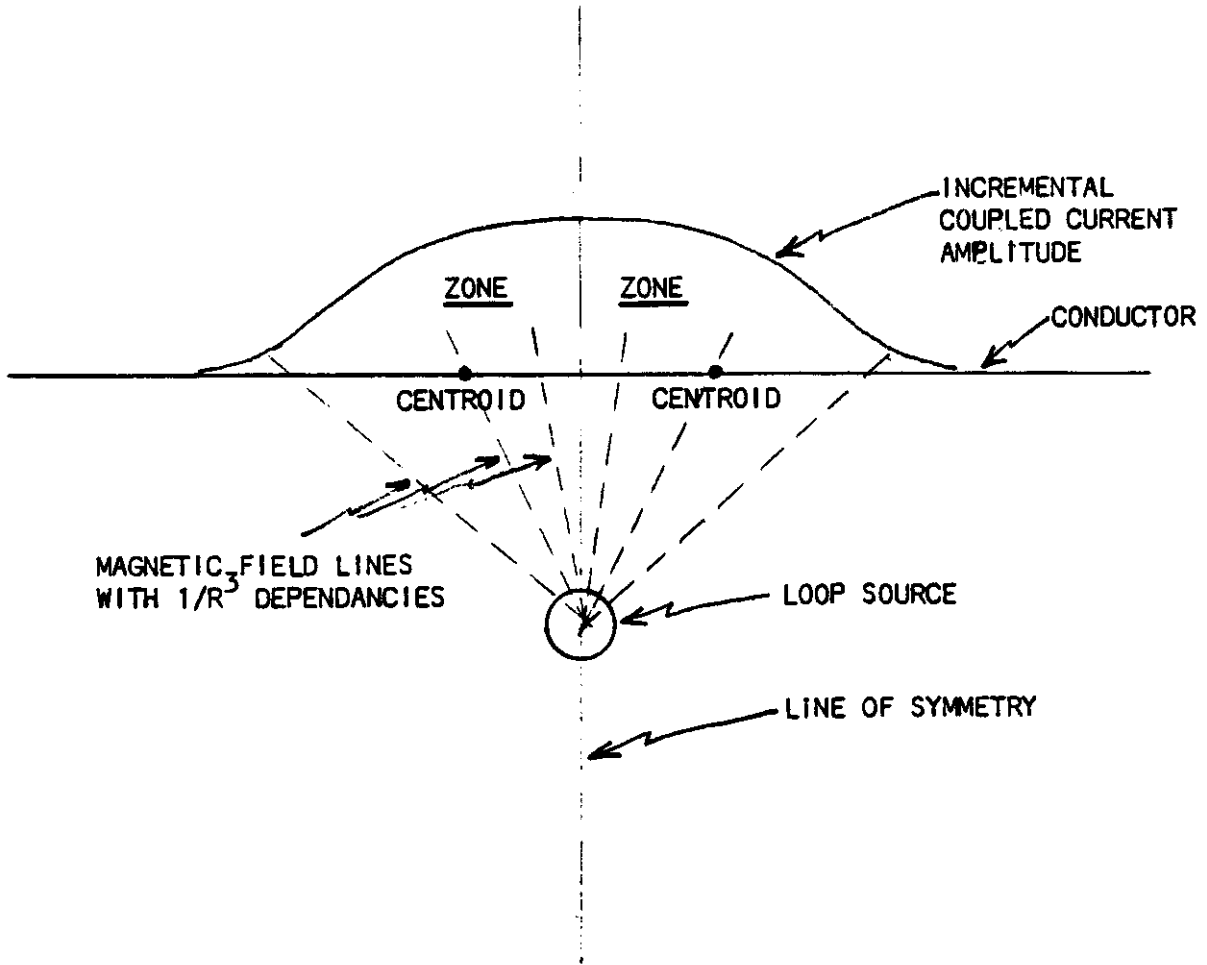

FIGURE 42
 GEOMETRY FOR INTERMEDIATE FREQUENCY COUPLING

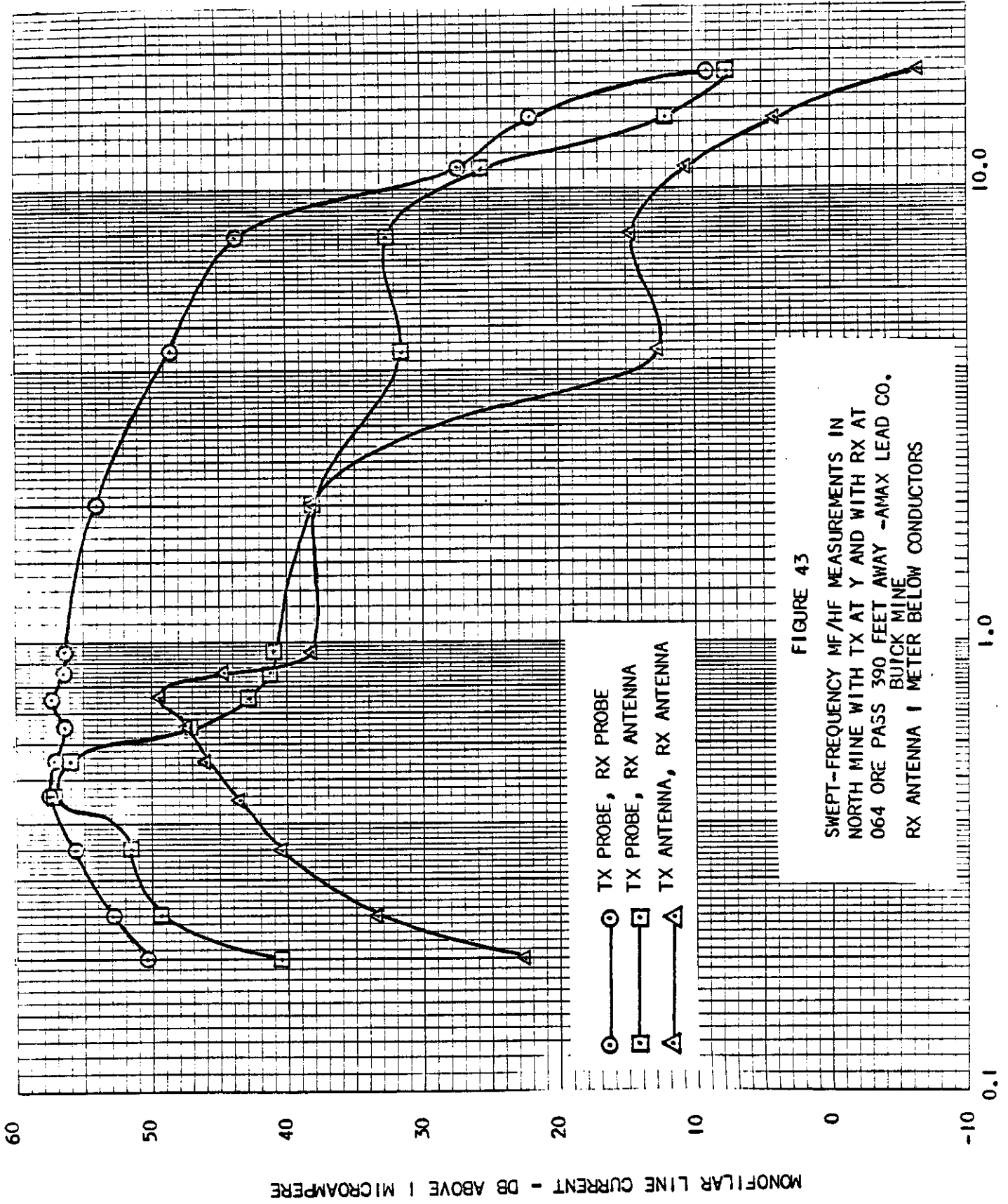

FIGURE 43
 SWEPT-FREQUENCY MF/HF MEASUREMENTS IN
 NORTH MINE WITH TX AT Y AND WITH RX AT
 064 ORE PASS 390 FEET AWAY -AMAX LEAD CO.
 BUTCK MINE
 RX ANTENNA 1 METER BELOW CONDUCTORS

will increase with frequency.

Originally, the coupling decrease in the HF band was thought to be due to the retarded frequency-variable field term which, in a constrained environment, becomes the waveguide mode excitation means. This "radiation" term with frequency-variable current moment represents stored evanescent energy below the waveguide cut-off frequency. While this mechanism occurs, it is a relatively narrowband effect, thus having minimal spectral impact in the highly attenuated HF region. This effect will not be specifically addressed further in this report.

The low-intermediate frequency coupling mechanisms to mine wiring show medium frequencies in the 200- 1000 KHz range to be optimum for wireless transmission. A summary of these computed coupling effects on transmission for the test system is illustrated in Figure 44. Additionally, even over particular short test ranges used for swept-frequency measurements, the monofilar line attenuation increases approximately linearly with frequency and predominates in the overall transmission loss toward the high end of the HF band and above. For the test system operating in the 1-10 MHz spectrum over a typical test range of about 300-400 feet, the average attenuation rate is about $1/f$. For practical operating ranges, the attenuation in the HF band becomes prohibitive. The average attenuation in drifts appears to be about 6 dB/1000 feet at 1 MHz varying linearly with frequency.

3.3.3 WAVEGUIDE TRANSMISSION

UHF transmission in coal mine tunnels has been carefully analyzed by Arthur D. Little, Inc. under Task Order #1, Task F on U.S.B.M. Contract HQ346045. The transmission loss due to refraction and roughness have a f^3 frequency dependence which is in good agreement with measured data. The ADL data shows that for narrow drift widths (8-12 feet) these losses are substantial up to a frequency of about 1000MHz, which is in good agreement with the 800 MHz assessment determined during this program. The lower frequency losses (450 MHz or below) were also substantiated for low drifts. The data obtained during this program showed that regardless of cross-sectional drift size, there was a substantial signal enhancement in the high 800-1000 MHz range. For mines with larger drifts the fully developed waveguide mode was not reached until 10-20 times cut-off. The concept of cut-off frequency, thus, has little meaning when the refractive and roughness losses govern over "copper" losses.

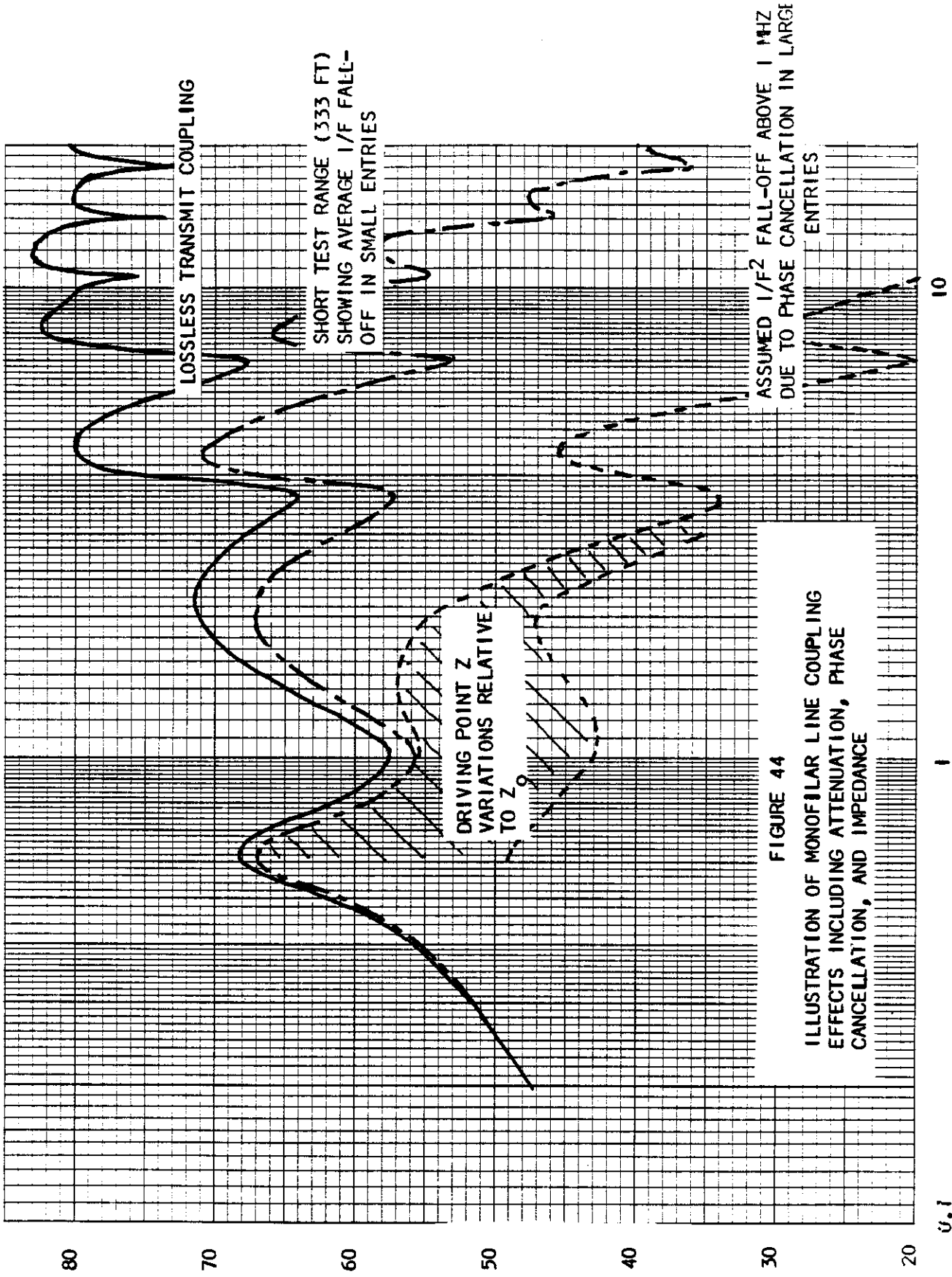

MONOFILAR LINE CURRENT IN DB ABOVE 1 MICRAMPERE

FIGURE 44

ILLUSTRATION OF MONOFILAR LINE COUPLING EFFECTS INCLUDING ATTENUATION, PHASE CANCELLATION, AND IMPEDANCE

FREQUENCY - MHZ

LOSSLESS TRANSMIT COUPLING

SHORT TEST RANGE (333 FT) SHOWING AVERAGE 1/F FALL-OFF IN SMALL ENTRIES

DRIVING POINT Z VARIATIONS RELATIVE TO Z_0

ASSUMED $1/F^2$ FALL-OFF ABOVE 1 MHZ DUE TO PHASE CANCELLATION IN LARGE ENTRIES

4.0 INDIVIDUAL MINE REDUCED TEST DATA

This section presents the reduced test data from the individual mines. This test data, both in graphic and tabular form, is representative data and does not necessarily include reductions of all test data gathered in each mine. Original test data is presented in the next section.

4.1 REDUCED DATA FROM OCCIDENTAL LOGAN WASH MINE

Swept-frequency data is given in Figure 45 (MF), Figure 46 (HF), Figure 47 (VHF) and Figure 48 (UHF) for two test locations.

Figure 49 shows VHF/UHF CW test data at several frequencies taken along an approximate 1000-foot segment of drift including a corner; this data is also given in Table 7.

Figure 50 shows CW MF test data loop-excited at 650 KHz for several test conditions within the drift cross-section over an approximate 600-foot test range; this data is also listed in Table 8. Figure 51 gives additional CW MF test data current-probe-coupled into a pager phone line at 650 KHz as measured over a test range of 1600 feet.

Figure 52 gives reduced 10 GHz CW test data taken over a test range of approximately 160 feet; this data is also listed in Table 9.

4.2 REDUCED DATA FROM UNITED NUCLEAR/HOMESTAKE PARTNERS SECTION 23 MINE

Swept-frequency data is given in Figures 53 and 54 and Tables 10 and 11 respectively for the Wagner and 650 track test areas for MF; Figure 55 and Table 12 for HF in the Wagner area; Figures 56 and 57 and Tables 13 and 14 respectively for the Wagner and 650 track test areas at VHF; Figures 58 and 59 plus Tables 15 and 16 respectively for the Wagner and 650 track areas at UHF.

MF CW test data at 650 KHz current-probe-coupled into the phone line for 480 VAC line cross-coupling in the Wagner drift area on a 812-foot range are given in Table 17. Mine-wide MF CW test data at 650 KHz over a 3360-foot range current-probe-coupled into the phone line are given in Table 18.

VHF/UHF CW test data taken in the Wagner drift area at several frequencies over a 512-foot test range are given in Table 19. Microwave 10 GHz CW test data taken over a 97-foot range are given in Table 20.

Processed MF swept-frequency data for flat -2 dB NIA over a 180-foot

FIGURE 45

OCCIDENTAL OIL SHALE LOGAN WASH. MINE
 RETORT #6 AREA - MEDIUM FREQUENCY SWEEP
 FIELD STRENGTH MEASUREMENTS AT TWO FIXED
 RANGES - 1 WATT POWER INTO PRACTICAL
 MAN-PACK LOOP ANTENNA CHARACTERIZATION
 CONDUCTOR-FREE

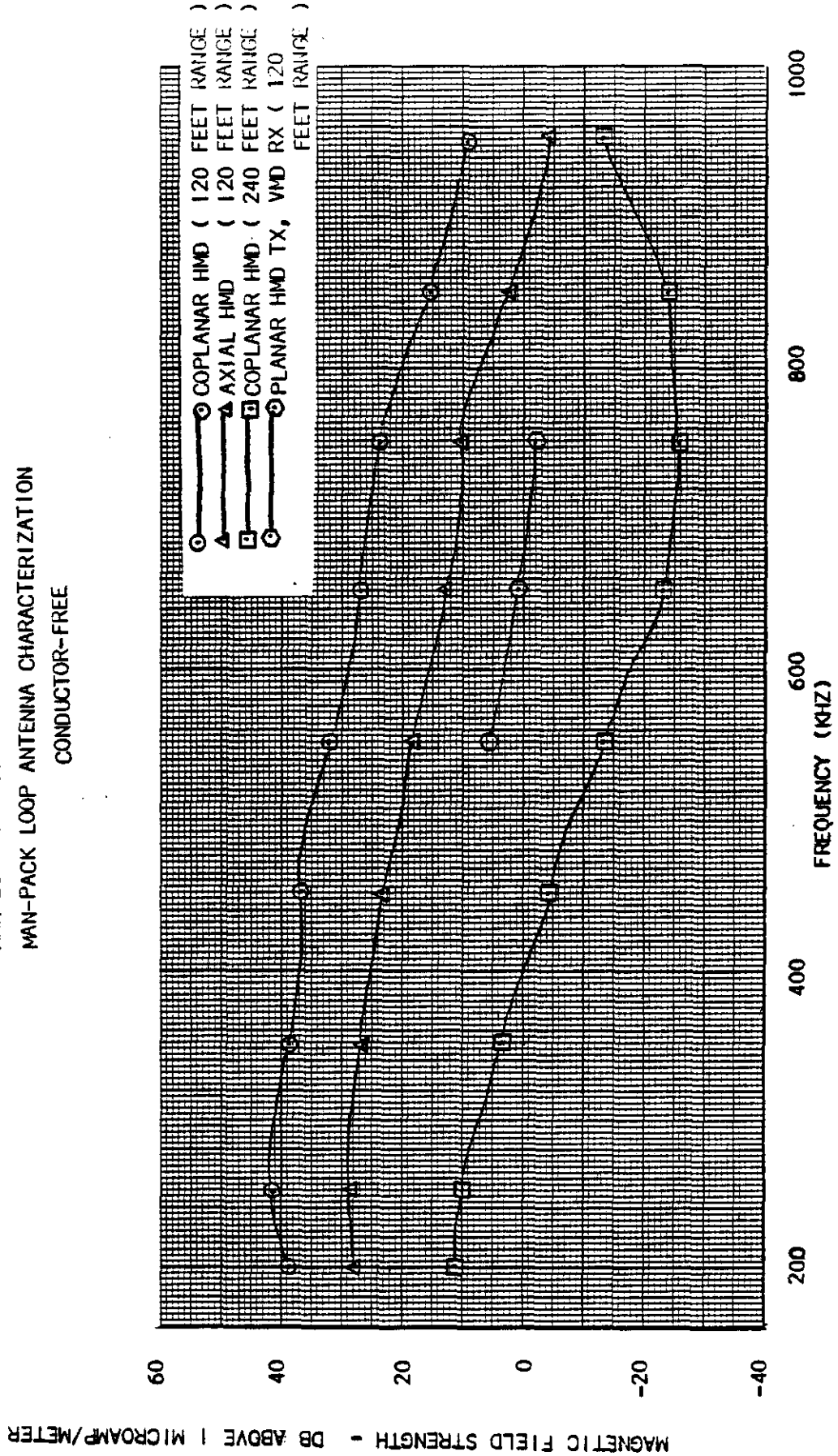

FIGURE 46

OCCIDENTAL OIL SHALE LOGAN WASH MINE
RETORT #6 AREA - HIGH FREQUENCY SWEPT
FIELD STRENGTH MEASUREMENTS AT 120 FEET
RANGE - 1 WATT POWER INTO PRACTICAL
MAN-PACK LOOP ANTENNA CHARACTERIZATION
CONDUCTOR-FREE

MAGNETIC FIELD STRENGTH - DB ABOVE 1 MICROAMP/METER

- 123 -

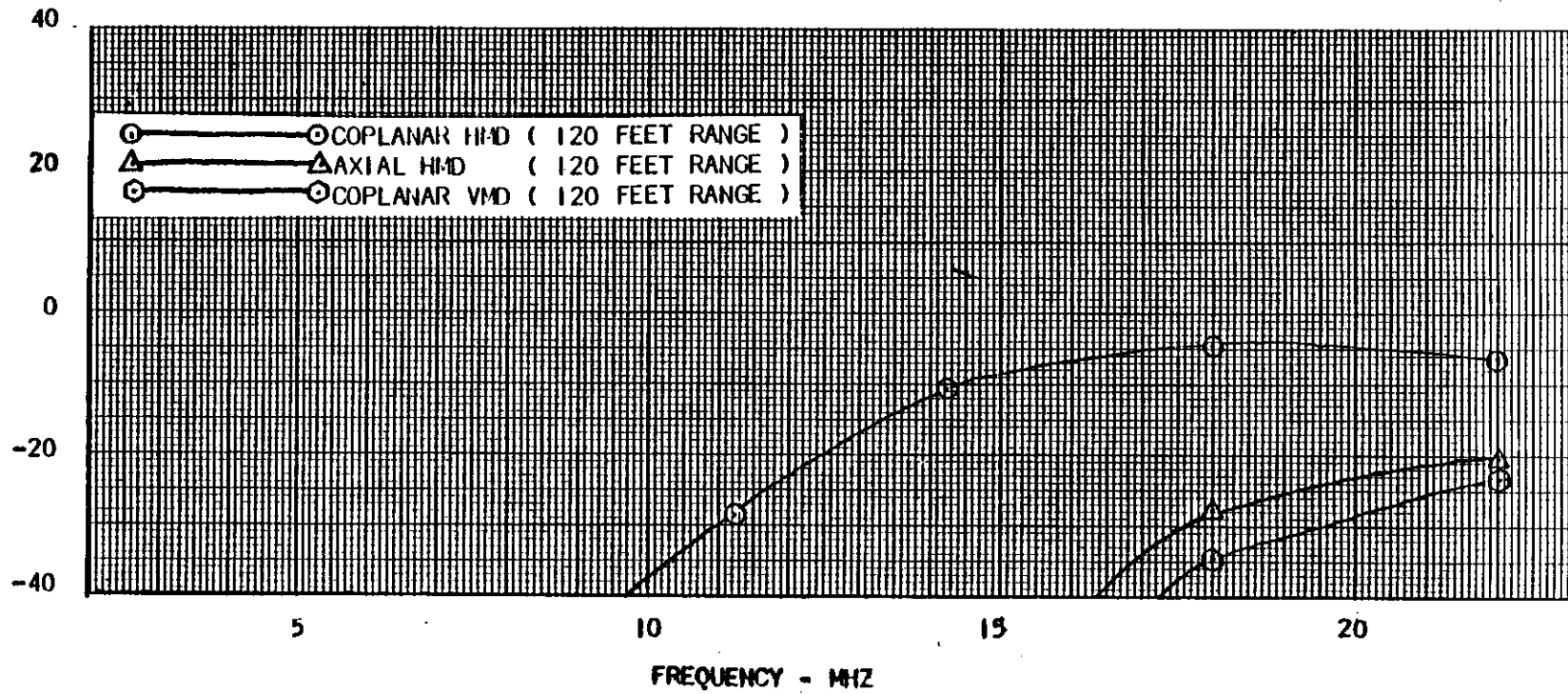

FIGURE 47

OCCIDENTAL OIL SHALE LOGAN WASH MINE
RETORT #6 AREA - VHF SWEPT FIELD STRENGTH
MEASUREMENTS AT TWO FIXED RANGES - 1 WATT
POWER INTO PRACTICAL MAN-PACK WHIP ANTENNA
CHARACTERIZATION CONDUCTOR-FREE

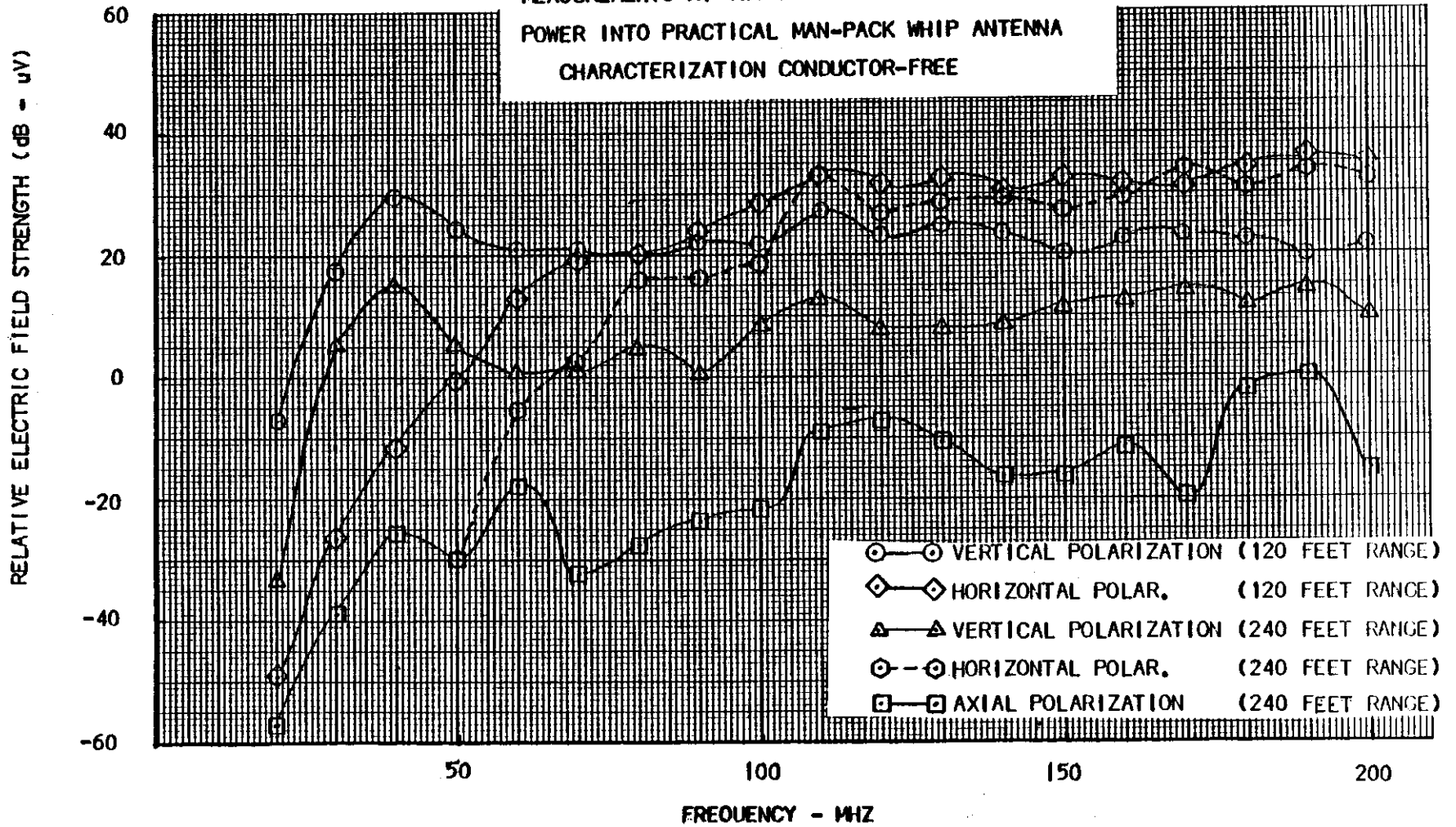
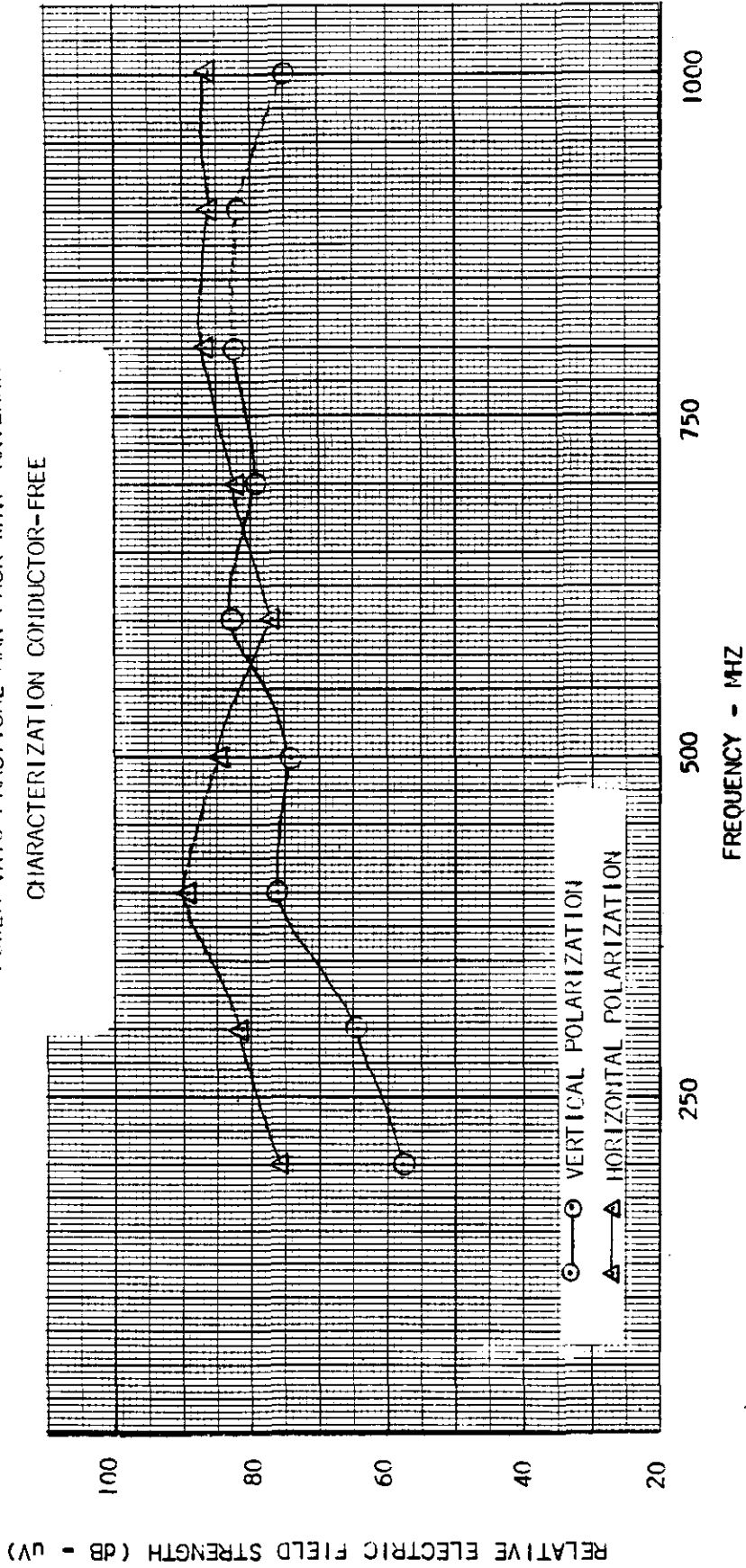

FIGURE 48

OCCIDENTAL OIL SHALE LOGAN WASH MINE
RETORT #6 AREA - UHF SWEPT FIELD STRENGTH
MEASUREMENTS AT 240 FEET RANGE - 1 WATT
POWER INTO PRACTICAL MATH-PACK WHIP ANTENNA
CHARACTERIZATION CONDUCTOR-FREE



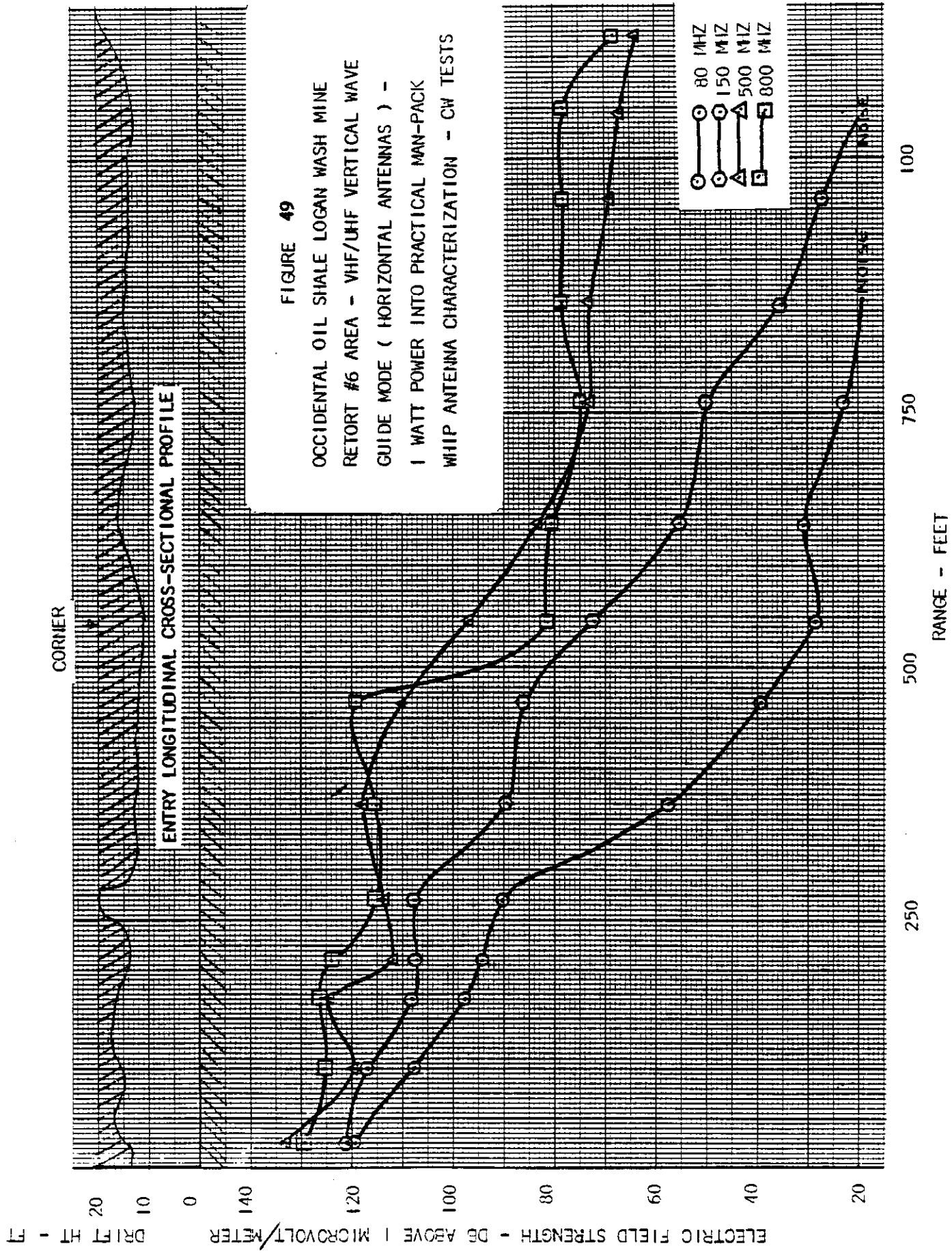

TABLE 7
 VHF/UHF CW FIELD STRENGTH MEASUREMENT DATA
 LOGAN WASH MINE

<u>LOCATION</u>	<u>FREQUENCY (READINGS IN dB)</u>			
	<u>80MHZ</u>	<u>150MHZ</u>	<u>500MHZ</u>	<u>800MHZ</u>
-1	112	103	103	94
0	100	99	89.5	90
1	90	90	94.5	91
2	86.5	89	82	89
3	82.5	89.5	83.8	80
4	50	71.5	88	80
5	32	68	80	84
6	20.5	54	67	46
7	23	37	53	45.5
8	15	32	43	39
9	NOISE	17	43	43.5
10		9	39	43
11		NOISE	37	43
12			34	33
13			NOISE	NOISE

FIGURE 50

LOOP-EXCITED MF MONOFILAR MODE PROPOGATION
 FIELD STRENGTH MEASUREMENTS FOR 1 WATT TRANSMIT
 POWER INTO A PRACTICAL MAN-CARRIED LOOP ANTENNA
 LOCATED TWENTY FEET FROM THE LOCAL CONDUCTORS
 (650KHZ SIGNAL) - LOGAN WASH MINE

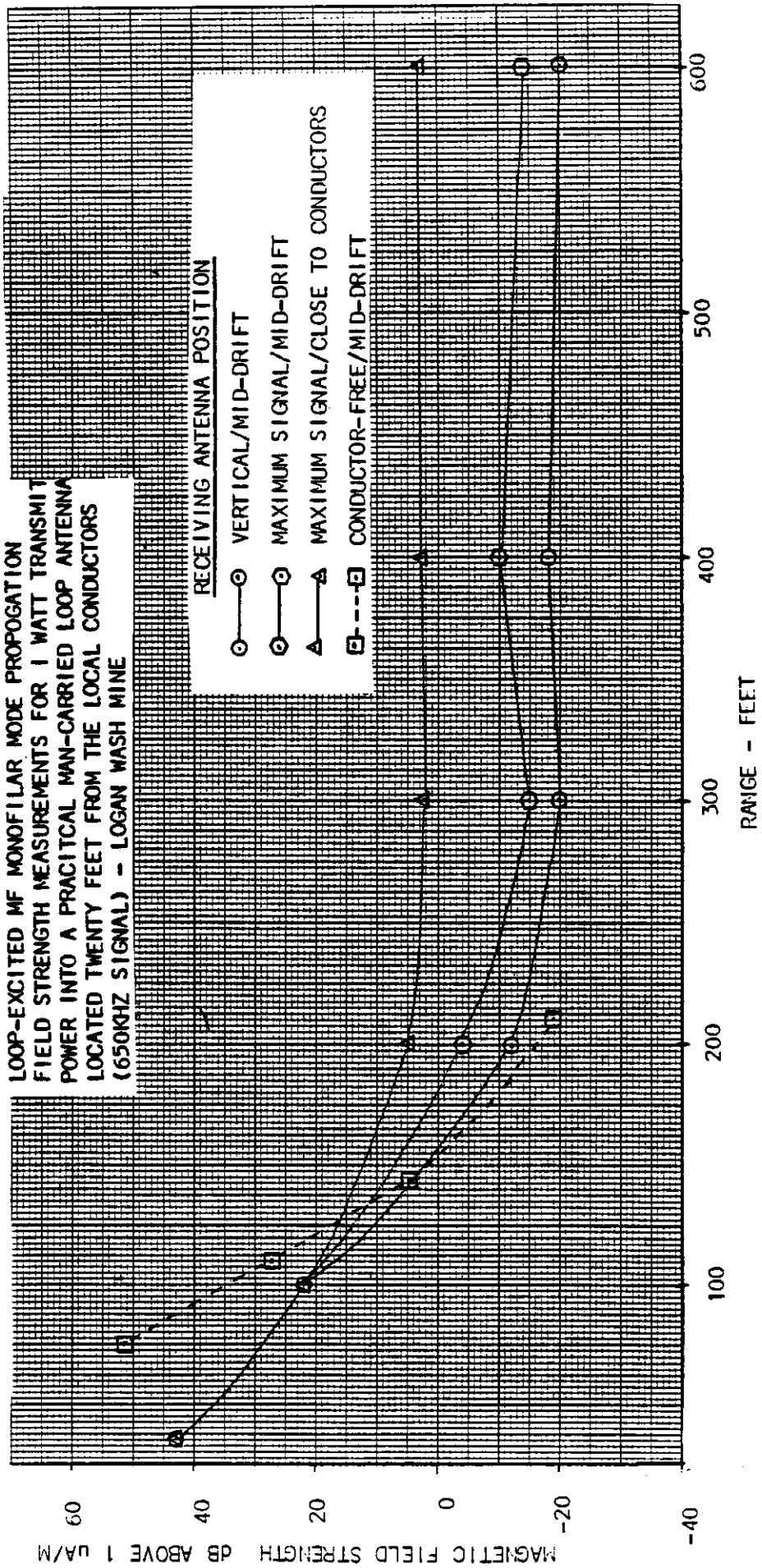

TABLE 8
 LOOP EXCITED MONOFILAR MODE 650KHZ FIELD
 STRENGTH MEASUREMENT DATA - LOGAN WASH MINE

<u>LOCATION</u>	<u>ANTENNA POSITION</u> (READINGS IN dB)		<u>NEAR CONDUCTORS</u>
	<u>VERTICAL/MID-DRIFT</u>	<u>MAXIMUM SIGNAL/MID-DRIFT</u>	
1	52		
2	31		
3	-3	5	14
4	-11.2	-6.2	11.3
5	-9	-1	12
6	-12	-6	11.5

FIGURE 51

CURRENT PROBE COUPLED MF MONOFILAR MODE
PROPAGATION MEASUREMENT USING A PAGER PHONE
CABLE AND 1.2 WATT TRANSMIT POWER AT 650KHZ

LOGAN WASH MINE

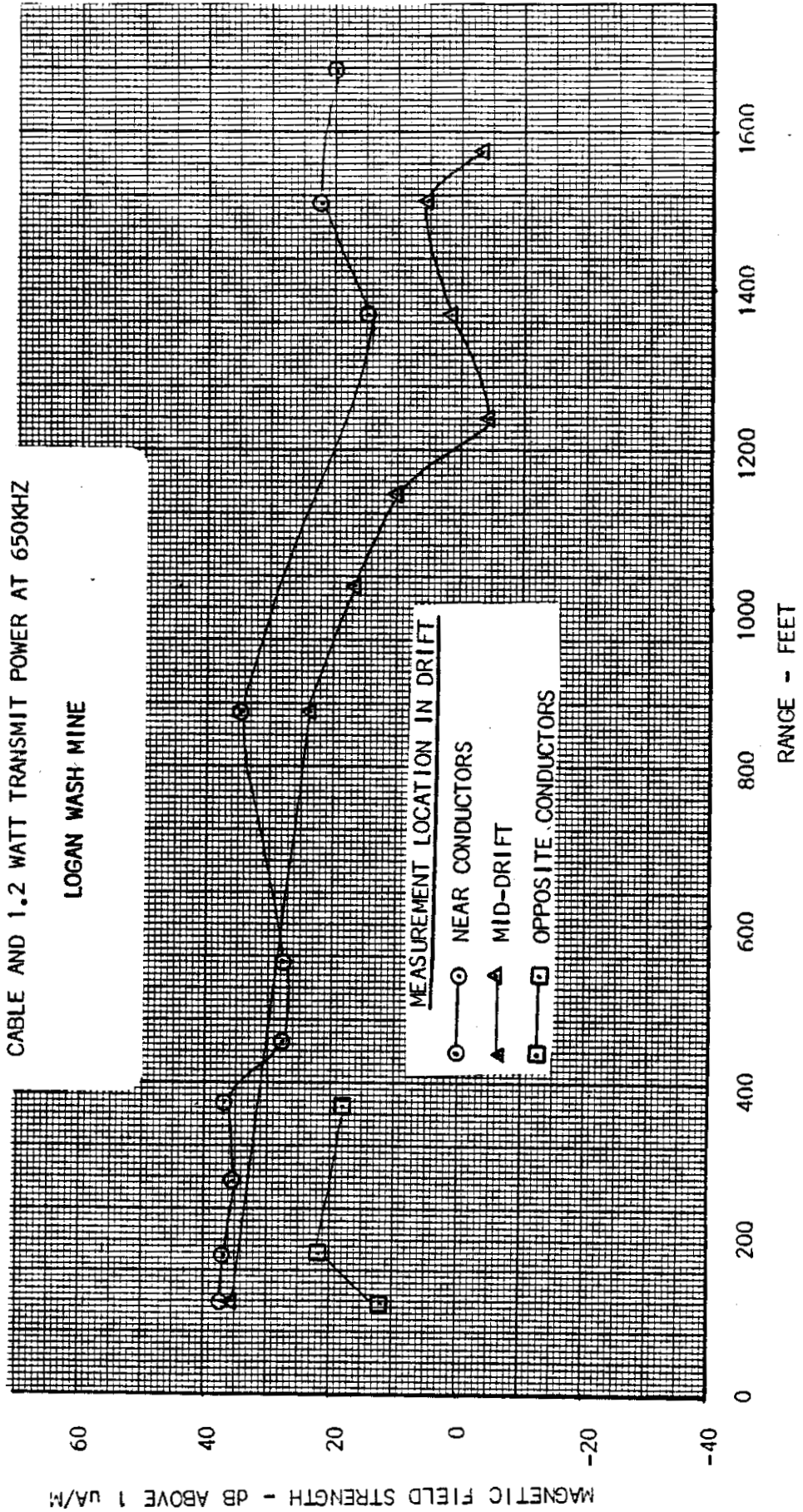

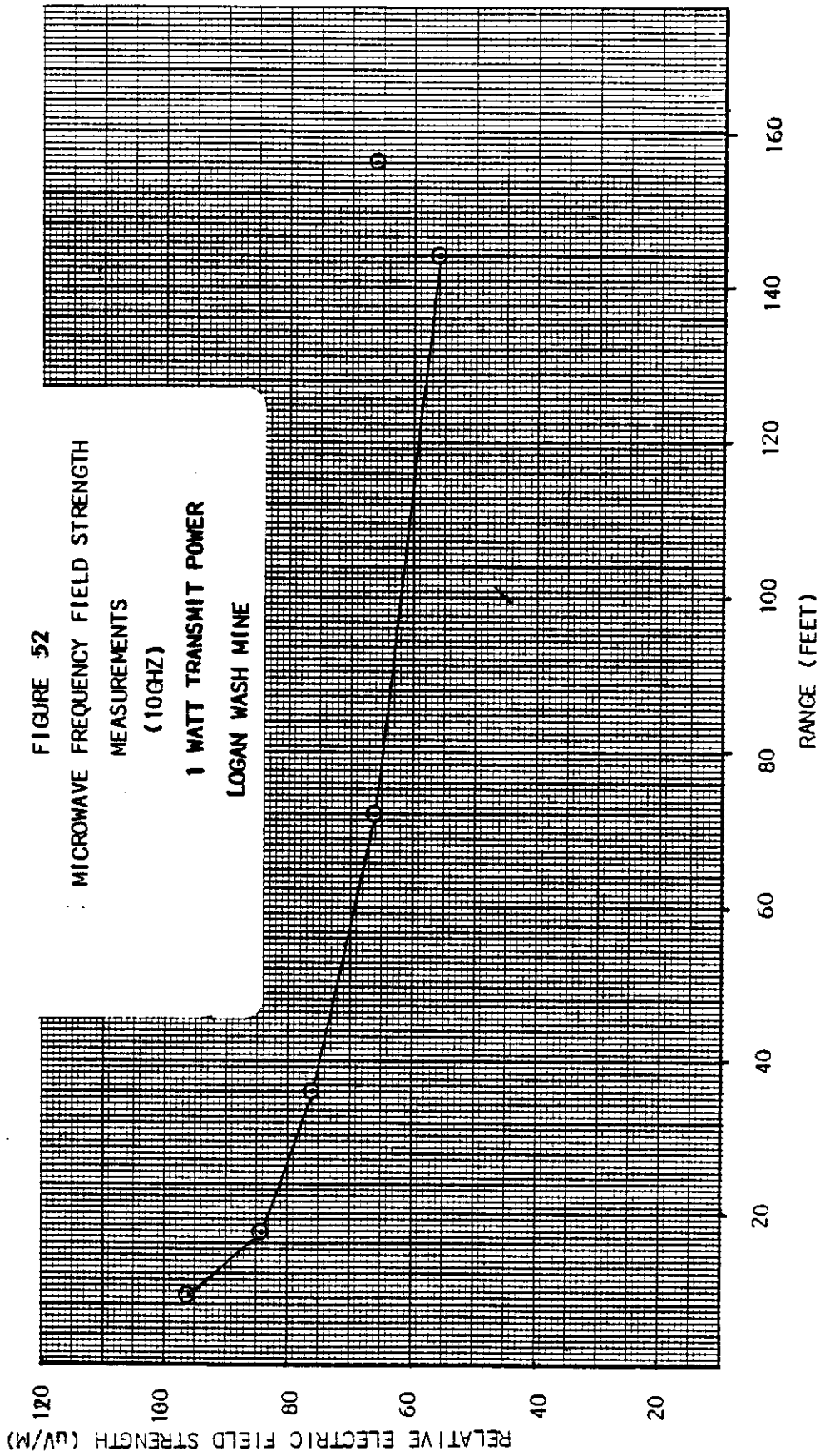
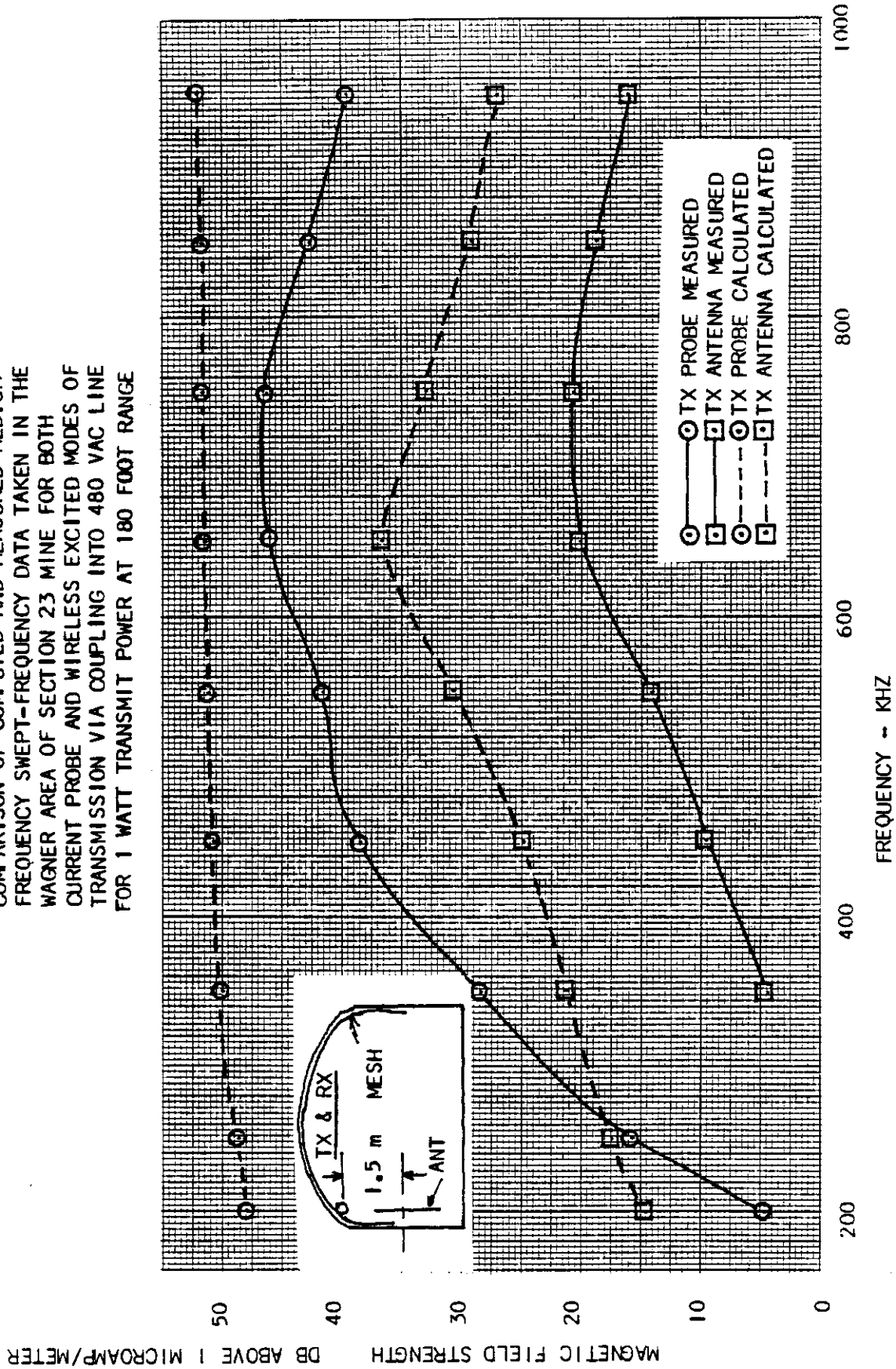

TABLE 9
MICROWAVE FIELD STRENGTH MEASUREMENT
DATA - LOGAN WASH MINE

<u>LOCATION</u>	<u>READING (uV)</u>
1	58
2	52
3	48
4	43
5	38
6	43

FIGURE 53

COMPARISON OF COMPUTED AND MEASURED MEDIUM-FREQUENCY SWEEP-FREQUENCY DATA TAKEN IN THE WAGNER AREA OF SECTION 23 MINE FOR BOTH CURRENT PROBE AND WIRELESS EXCITED MODES OF TRANSMISSION VIA COUPLING INTO 480 VAC LINE FOR 1 WATT TRANSMIT POWER AT 180 FOOT RANGE



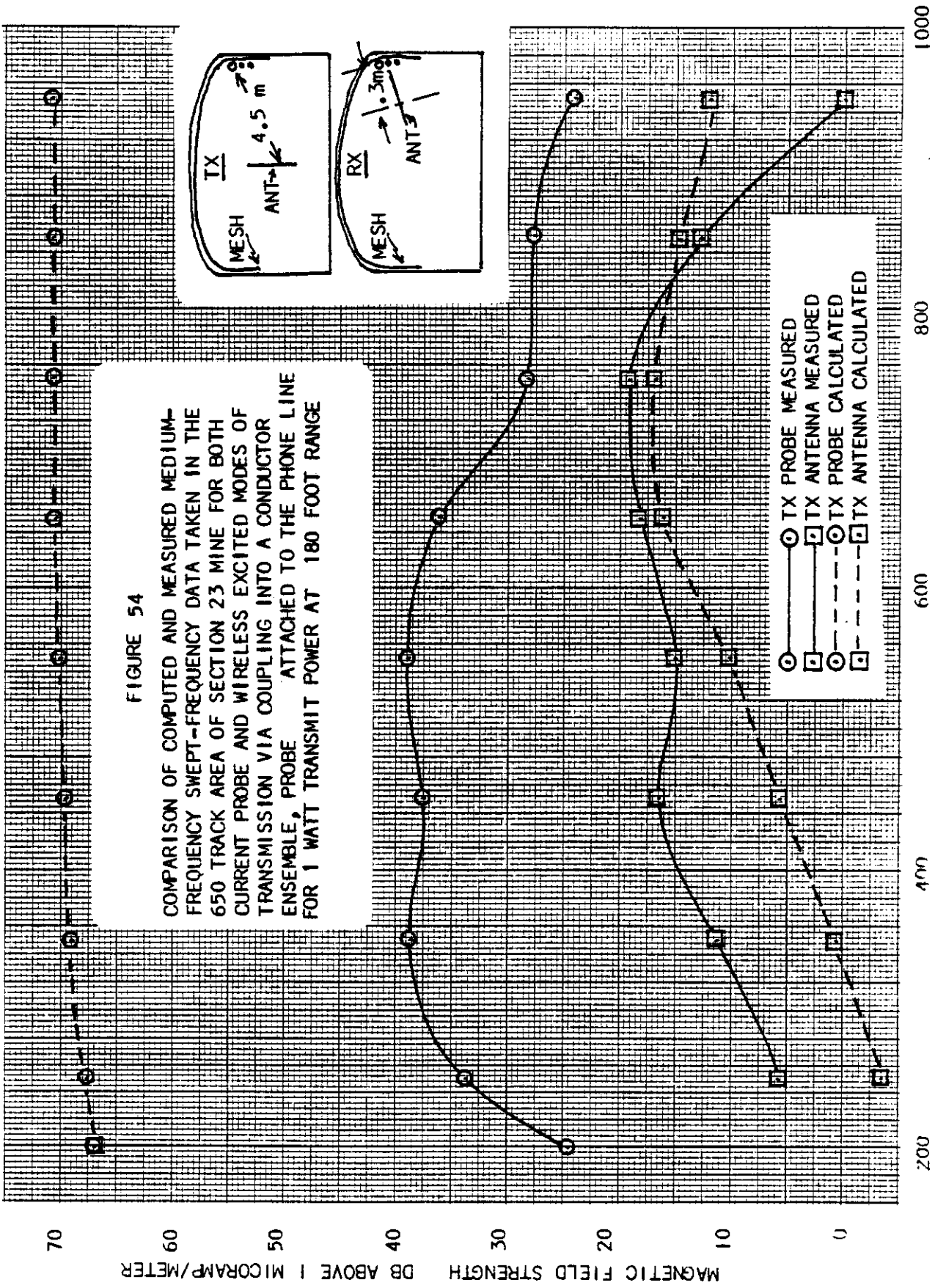

TABLE 10
 REDUCED SWEPT-FREQUENCY MF DATA TAKEN IN WAGNER AREA
 UNITED NUCLEAR SECTION 23 MINE
 1 WATT TRANSMIT POWER AT 180 FOOT RANGE

FREQ(MHZ)	TX CURRENT PROBE MAG FIELD STRENGTH DB ABOVE 1 μ A/M	TX ANTENNA MAG FIELD STRENGTH DB ABOVE 1 μ A/M
0.20	+ 4.5	-
0.25	+15.7	-
0.35	+28.4	+ 4.4
0.45	+38.5	+ 9.5
0.55	+41.5	+14.0
0.65	+46.1	+20.1
0.75	+46.3	+20.8
0.85	+42.7	+18.7
0.95	+39.5	+16.0

TABLE 11
 REDUCED SWEPT-FREQUENCY MF DATA TAKEN IN 650 TRACK AREA
 UNITED NUCLEAR SECTION 23 MINE
 1 WATT TRANSMIT POWER AT 180 FOOT RANGE

FREQ(MHZ)	TX CURRENT PROBE MAG FIELD STRENGTH DB ABOVE 1 μ A/M	TX ANTENNA MAG FIELD STRENGTH DB ABOVE 1 μ A/M
0.20	+24.5	-
0.25	+33.7	+ 5.7
0.35	+38.9	+11.4
0.45	+37.5	+16.5
0.55	+39.0	+15.0
0.65	+36.1	+18.1
0.75	+28.3	+19.3
0.85	+27.7	+12.7
0.95	+24.0	0

MAGNETIC FIELD STRENGTH DB ABOVE 1 MICROAMP/METER

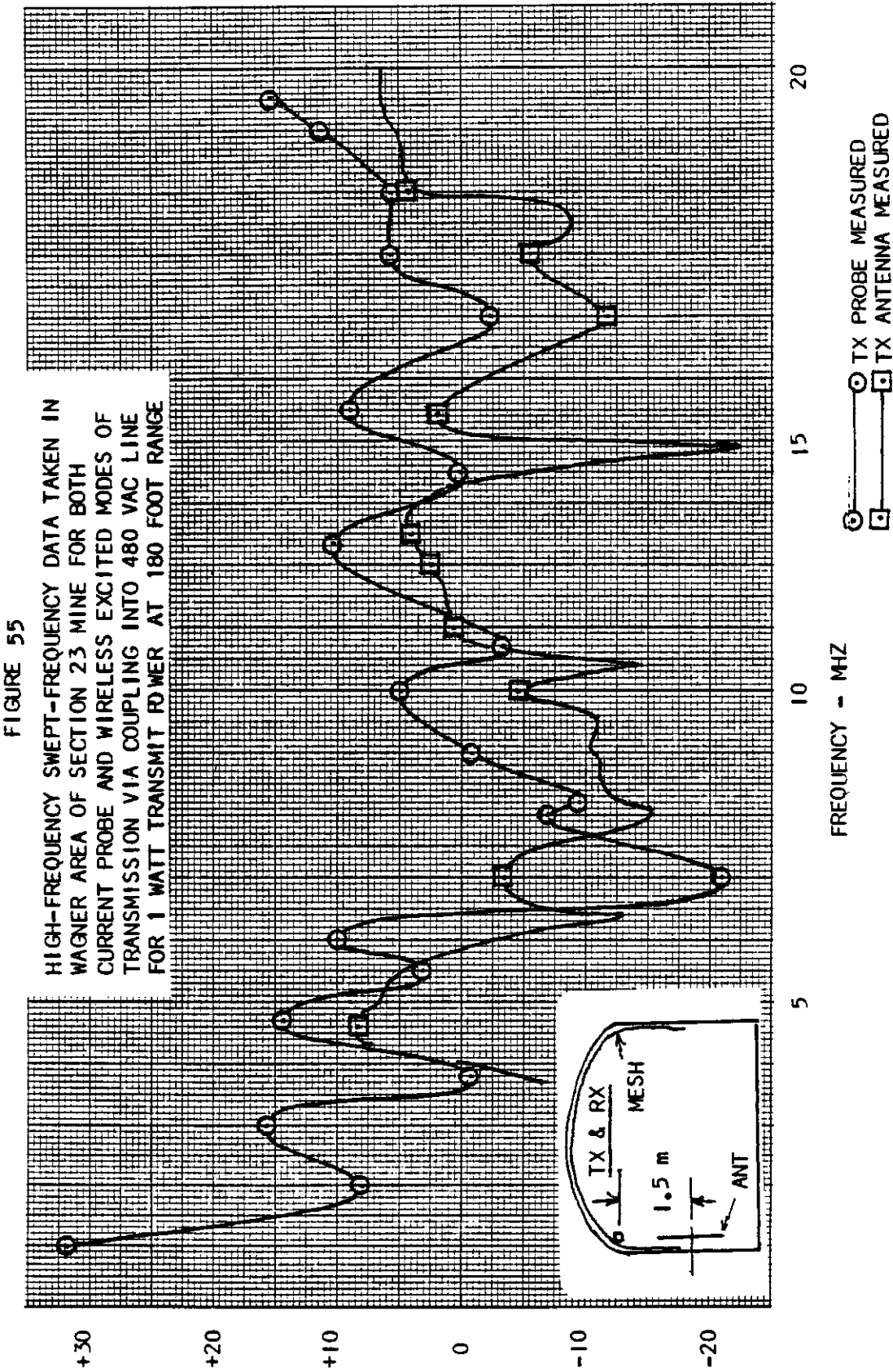

TABLE 12
 REDUCED SWEPT-FREQUENCY HF DATA TAKEN IN WAGNER AREA
 UNITED NUCLEAR SECTION 23 MINE
 1 WATT TRANSMIT POWER AT 180 FOOT RANGE

FREQ(MHZ)	TX CURRENT PROBE MAG FIELD STRENGTH DB ABOVE 1 μ A/M	TX ANTENNA MAG FIELD STRENGTH DB ABOVE 1 μ A/M
1.0	+32.0	
2.0	+ 8.0	
3.0	+15.7	
3.8	- 0.7	
4.4		+ 8.2
4.7	+14.4	
5.5	+ 3.1	
6.0	+10.0	
7.0	- 2.3	
7.5		- 3.5
8.0	- 6.5	
8.2	- 9.5	
9.0	- 0.8	
10.0	+ 5.0	
10.7	- 3.2	
11.0		+ 0.8
12.0		+ 2.5
12.3	+10.4	
12.5		+ 4.4
13.5	+ 0.2	
14.5	+ 9.0	+ 2.0
16.0	- 2.2	
17.0	+ 5.7	
18.0	+ 5.7	+ 4.7
19.0	+11.6	
19.5	+15.6	

FIGURE 56

VHF SWEEP-FREQUENCY DATA TAKEN IN WAGNER AREA OF UNITED NUCLEAR SECTION 23 MINE FOR SEVERAL POLARIZATION ORIENTATIONS OF BICONICAL TEST ANTENNAS - NORMALIZED FOR 1-WATT INTO PRACTICAL MAN-PACK WHIP ANTENNA CHARACTERIZATION AT 180 FOOT RANGE

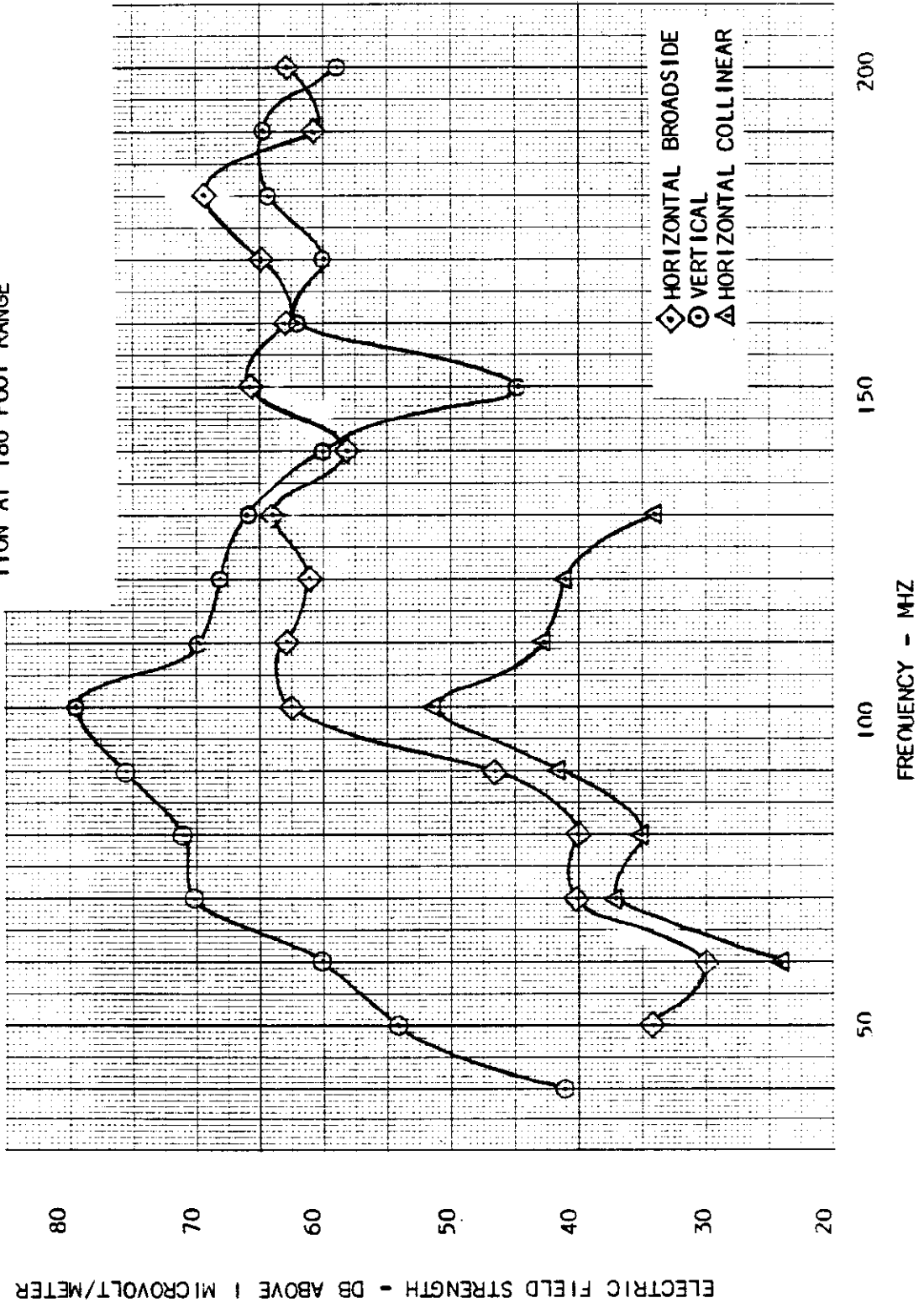

FIGURE 57

VHF SWEEP-FREQUENCY DATA TAKEN IN 650 TRACK AREA OF UNITED NUCLEAR SECTION 23 MINE FOR SEVERAL POLARIZATION ORIENTATIONS OF BICONICAL TEST ANTENNAS - NORMALIZED FOR 1-WATT INTO PRACTICAL MAN-PACK WHIP ANTENNA CHARACTERIZATION AT 180 FOOT RANGE

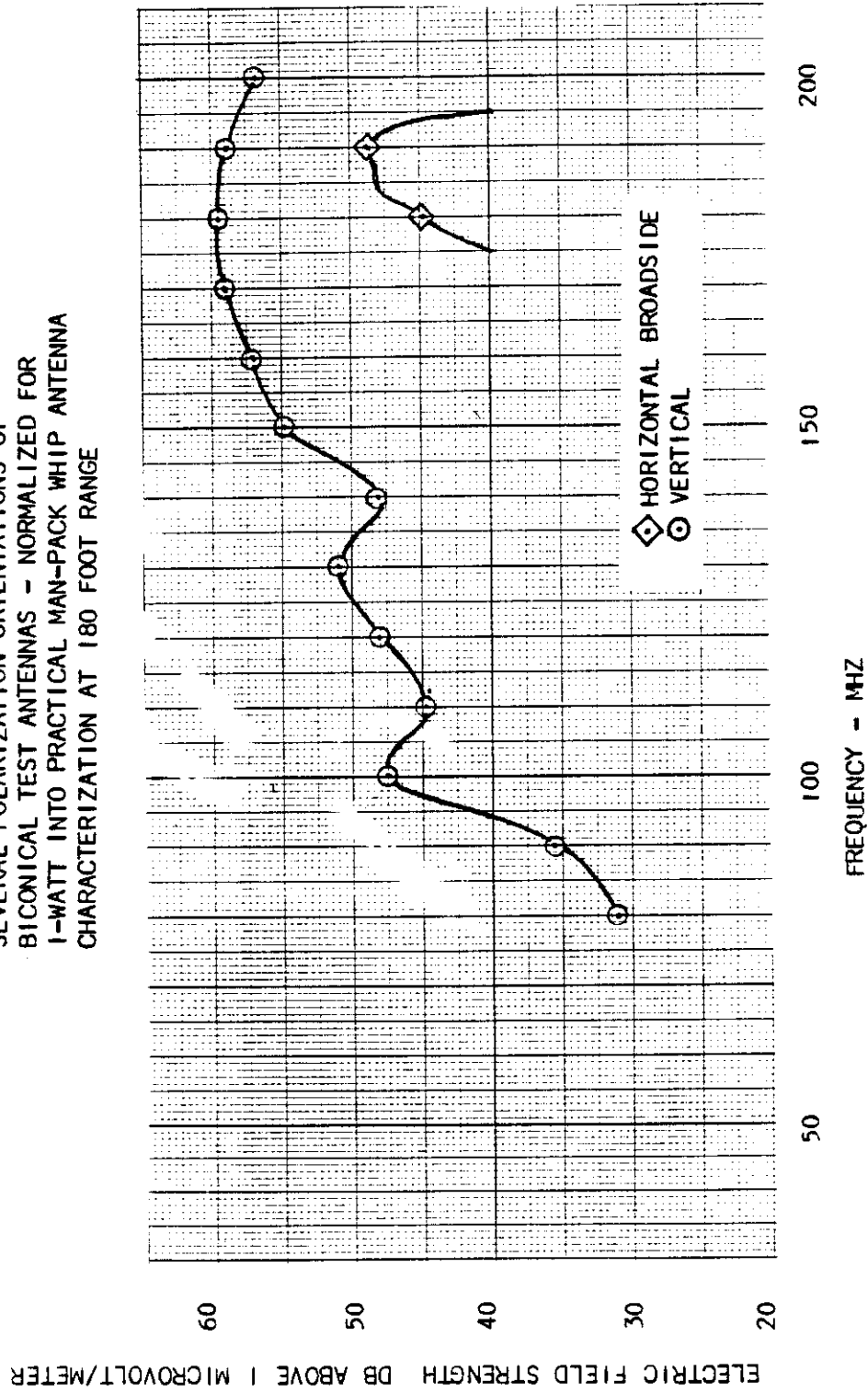

TABLE 13
 REDUCED SWEPT-FREQUENCY VHF DATA TAKEN IN WAGNER AREA
 OF UNITED NUCLEAR SECTION 23 MINE
 1-WATT TRANSMIT POWER AT 180 FOOT RANGE

FREQ(MHZ)	H-POL BROADSIDE DB ABOVE 1 μ V/M	V-POL DB ABOVE 1 μ V/M	H-POL COLLINEAR DB ABOVE 1 μ V/M
40	-	41.2	-
50	34.2	54.2	-
60	30.1	60.1	24.1
70	40.2	70.2	37.2
80	40.1	71.1	35.1
90	46.6	75.6	41.6
100	62.5	79.5	51.5
110	62.8	69.8	42.8
120	61.1	68.1	41.1
130	64.0	66.0	34.0
140	58.1	60.1	-
150	65.8	44.8	-
160	63.1	62.1	-
170	65.0	60.0	-
180	69.4	64.4	-
190	60.8	64.8	-
200	62.8	58.8	-

TABLE 14

REDUCED SWEEP-FREQUENCY VHF DATA TAKEN IN 650 TRACK AREA
OF UNITED NUCLEAR SECTION 23 MINE
1 WATT TRANSMIT POWER AT 180 FOOT RANGE

FREQ(MHZ)	H-POL BROADSIDE DB ABOVE 1 μ V/M	V-POL DB ABOVE 1 μ V/M
80	-	31.1
90	-	35.6
100	-	47.5
110	-	44.8
120	-	48.1
130	-	51.0
140	-	48.1
150	-	54.8
160	-	57.1
170	-	59.0
180	44.4	59.4
190	48.8	58.8
200	-	56.8

FIGURE 58

UHF SWEPT-FREQUENCY DATA TAKEN IN WAGNER AREA
 FOR BOTH PRINCIPAL POLARIZATIONS OF THE LOG-
 PERIODIC TEST ANTENNAS - NORMALIZED FOR
 1-WATT INTO PRACTICAL MAN-PACK WHIP ANTENNA
 CHARACTERIZATION AT 180 FOOT RANGE

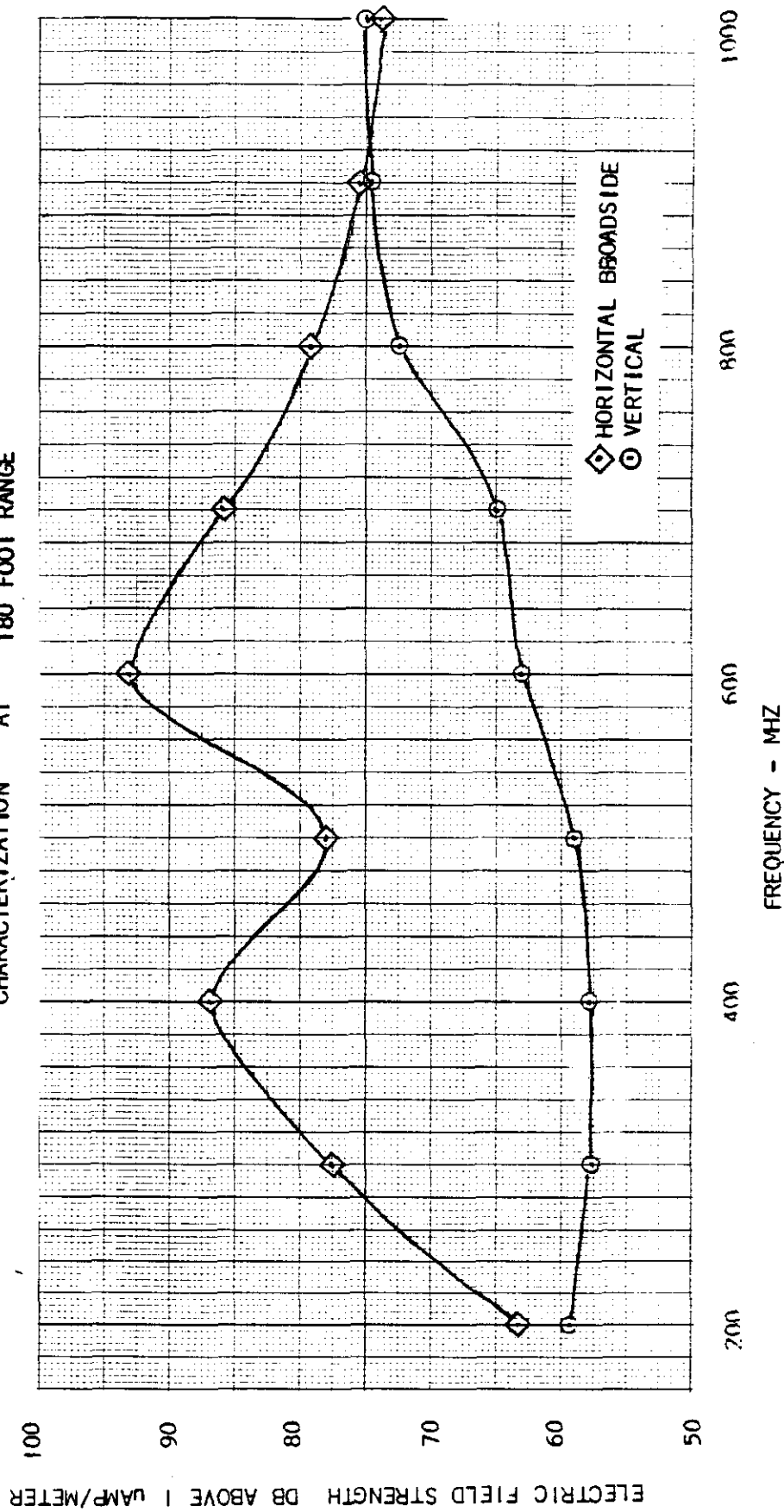

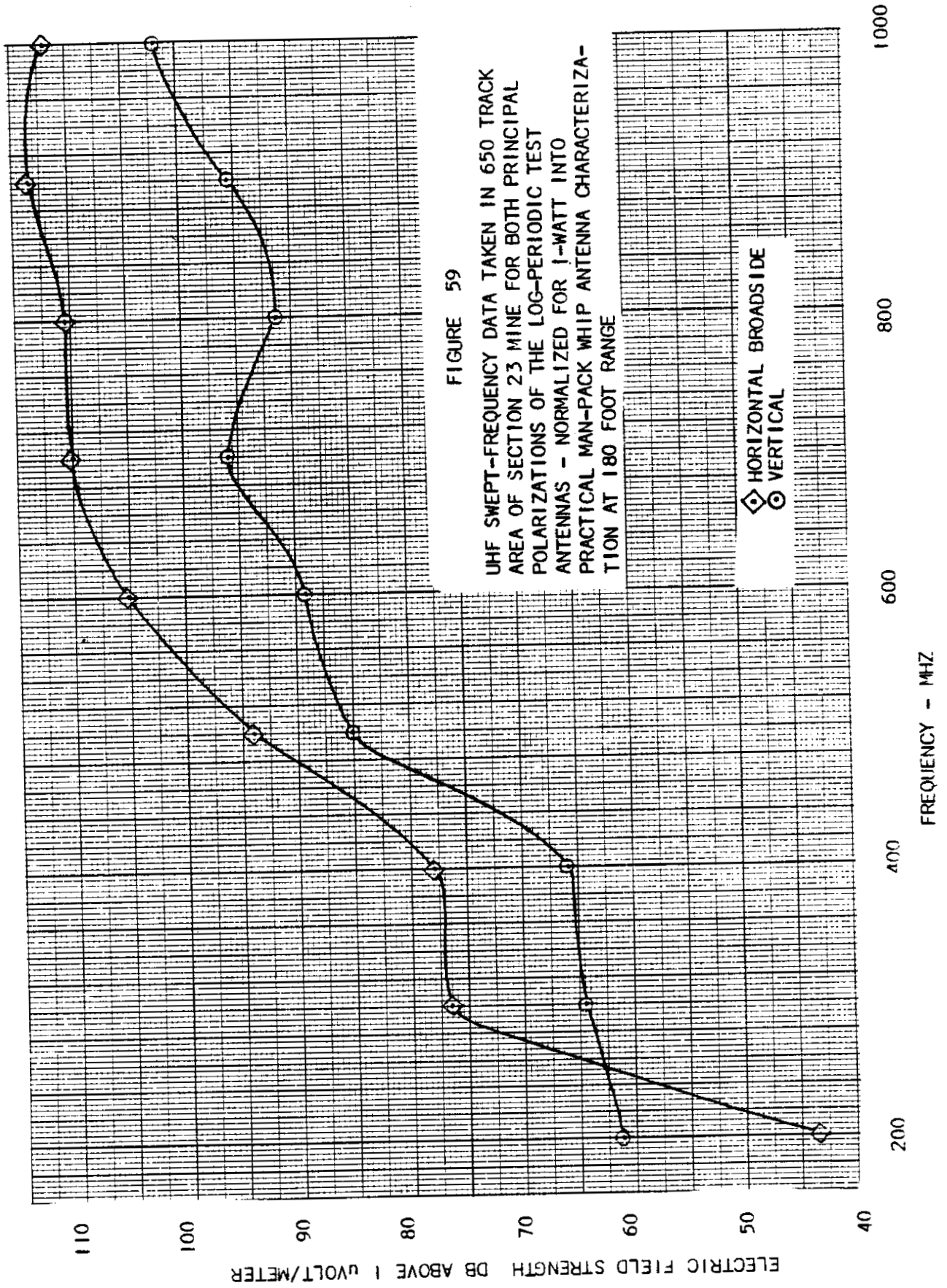

TABLE 15

REDUCED SWEEP-FREQUENCY UHF DATA TAKEN IN WAGNER AREA
 UNITED NUCLEAR SECTION 23 MINE
 1 WATT TRANSMIT POWER AT 180 FOOT RANGE

FREQ(MHZ)	H-POL BROADSIDE DB ABOVE 1 μ V/M	V-POL DB ABOVE 1 μ V/M
200	63.3	59.3
300	77.6	57.6
400	86.9	57.9
500	78.1	59.1
600	93.2	63.2
700	86.0	65.0
800	79.5	72.5
1000	74.0	70.0

TABLE 16

REDUCED SWEEP-FREQUENCY UHF DATA TAKEN IN 650 TRACK AREA
 UNITED NUCLEAR SECTION 23 MINE
 1 WATT TRANSMIT POWER AT 180 FOOT RANGE

FREQ(MHZ)	H-POL BROADSIDE DB ABOVE 1 μ V/M	V-POL DB ABOVE 1 μ V/M
200	43.3	61.3
300	76.6	64.6
400	77.9	65.9
500	94.1	85.1
600	105.2	89.2
700	110.0	96.0
800	110.5	91.5
900	113.6	95.6
1000	112.0	102.0

TABLE 17
 CW MEDIUM FREQUENCY DATA IN WAGNER DRIFT AREA
 AT 650 KHz
 UNITED NUCLEAR SECTION 23 MINE
 (Readings taken in the center of the drift)

LOCATION	MAGNETIC FIELD STRENGTH DB ABOVE 1 μ AMP/METER	RAW SINGER NM-25 DATA	DISTANCE FROM TX FT
0	+55.8	+24 on +40	14
1	+51.8	+20 on +40	114
2	+44.3	+12½ on +40	206
3 heater feed	+43.8	+12 on +40	302
4	+24.8	+13 on +20	394
5	+24.3	+12½ on +20	512
6 heater feed	+21.8	+10 on +20	626
7 heater feed	+ 2.8	+11 on 0	716
8	-	lost signal	812

- NOTES: 1. TRANSMITTER CONNECTED TO PHONE LINE VIA STODDARD CURRENT PROBE AT PRINCIPAL WAGNER AREA TX LOCATION
2. DATA NORMALIZED TO 1-WATT OF TX POWER (NIA = 0.89)

TABLE 18

CW MEDIUM FREQUENCY DATA OVER LARGE MINE AREA FROM
 TX LOCATED IN PRINCIPAL WAGNER AREA LOCATION OF
 UNITED NUCLEAR SECTION 23 MINE WITH COUPLING TO
 PHONE LINE VIA STODDARD CURRENT PROBE
 AT 650 KHz

(Readings taken in drift center unless otherwise noted)

LOCATION	NOTES	MAGNETIC FIELD STRENGTH DB ABOVE 1 uAMP/METER	RAW SINGER NM-25 DATA	DISTANCE FROM TX FT
A	WAGNER SHOP			
	NEAR PHONE	+24.3	+12½ on +20	1280
	MIN LEVEL	+11.8	0 on +20	
	MAX LEVEL	+34.8	+23 on +20	
B		+33.8 to +43.8	+(22-32) on +20	1880
C		+54.8	+23 on +40	1340
D	650 LEVEL PORTAL SHAFT	+48.8	+17 on +40	1700
E	726 LEVEL PORTAL SHAFT	+14.8	+23 on 0	1780
F		- 2.2	+ 6 on 0	2120
G	58 EAST TRACK BRANCH	-18.2	+10 on -20	2820
	MAIN 726 LEVEL TRACK	- 4.2	+ 4 on 0	
H		- 3.2	+ 5 on 0	2360
I	DRIFT CENTER	- 4.2	+ 4 on 0	3360
	ANT ON RAILS	+ 3.8	+12 on 0	

NOTE: RECEIVE SENSITIVITY LEVEL APPROX. -34 DB ABOVE 1 uAMP/METER
 FOR 12 DB SIGNAL, THEREFORE AMPLE SIGNAL IS AVAILABLE AT ALL
 TEST POINTS FOR COMMUNICATIONS DATA NORMALIZED TO 1 WATT
 TRANSMIT POWER

TABLE 19

CW VHF DATA TAKEN IN WAGNER DRIFT AREA
UNITED NUCLEAR SECTION 23 MINE

(Readings taken in the center of the drift)

VERTICAL POLARIZATION

ELECTRIC FIELD STRENGTH IN DB ABOVE 1 μ V/M

LOCATION	50 MHZ	100 MHZ	200 MHZ	DISTANCE(FT)
0	105.7	112.8	111.7	14
1	52.7	75.8	71.7	114
2	lost	35.8	34.7	206
3	lost	lost	lost	362

HORIZONTAL POLARIZATION

ELECTRIC FIELD STRENGTH IN DB ABOVE 1 μ V/M

LOCATION	50 MHZ	100 MHZ	200 MHZ	DISTANCE(FT)
0	78.7	123.8	119.7	14
1	lost	84.8	97.7	114
2	lost	39.8	65.7	206
3	lost	41.8	69.7	302
4	lost	45.8	45.7	394
5	lost	lost	lost	512

CORNER

NOTE: DATA NORMALIZED TO 1-WATT OF TX POWER INTO PRACTICAL
MAN-PACK ANTENNA

TABLE 20

X-BAND MICROWAVE TEST DATA TAKEN IN WAGNER AREA
 UNITED NUCLEAR SECTION 23 MINE 1 WATT TRANSMIT POWER

(A) RANGE TEST -

NM-65T READINGS DB ABOVE 1 μ V	FIELD STRENGTH DB ABOVE 1 μ V/M	RANGE (FT)
48.5	81.4	17
44	76.9	55
38	70.9	67
29	61.9	97

NOTE: Noise level at 29 DBuV on NM-65T

(B) DEPOLARIZATION TEST -

TX SET-UP AT WAGNER AREA TRANSMIT SITE

RX FIELD STRENGTH INCIDENT ON REFLECTOR:

66.9 μ V/M NOMINAL

3 DB VARIATION IN VERTICAL PLANE

6 DB VARIATION IN HORIZONTAL PLANE

TRANSVERSE TO DIRECTION OF PROPAGATION

RX REFLECTED FIELD STRENGTH @ 18 FEET RANGE FROM REFLECTOR:

66.4 DB RELATIVELY INDEPENDENT OF SPECIFIC
 LONGITUDINAL DIRECTION LOCATION OF
 RX HORN

range in the Wagner area are shown in Figure 60. Attenuation is assumed negligible over this range due to mesh on the back and ribs.

A summary of conductor ensemble impedances deduced from MF measurements is given in Table 21.

4.3 REDUCED DATA FROM KERR-MCGEE HOBBS POTASH FACILITY MINE

Swept-frequency data is given in Figure 61 for MF at two test ranges, Figure 62 for HF at a 300-foot range, Figure 63 for VHF at two test ranges and Figures 64 at a test range of 150. Additionally, MF current probe excited measurement at a range of 300 feet is given in Figure 65.

MF CW test data at several frequencies antenna-coupled over a nominal 750-foot test range is given in Figure 66 and in Table 22. More detailed MF CW test data at 650 KHz over an approximate 9500-foot test range is given in Figure 67 and in Table 23.

UHF CW data @ 600 and 950 MHz over an approximate 1600-foot test range is given in Figure 68 and in Table 24. 10 GHz CW test data over a 195-foot test range is given in Table 25. Processed MF swept-frequency data for flat -2 dB NIA taken over a 150-foot test range is given in Figure 69 with and without attenuation.

4.4 REDUCED DATA FROM THE AMAX LEAD CO. OF MISSOURI BUICK MINE

A composite of MF swept-frequency data taken vs range out to approximately 6800 feet in the haulage area beyond the Y is given in Figures 70 and 71 and in Table 26. Similar CW test data over the same range at 520 KHz for antenna loop coupling into phone line and dedicated wire is given in Figure 72 and in Table 27.

MF and HF swept-frequency data over a 390-foot test range is given in Figure 73 and respectively in Tables 28 and 29. Similar swept-frequency test data over a 1290-foot test range having the same transmitter location is given in Figure 74 and respectively in Tables 30 and 31. VHF and UHF swept-frequency data over a 390-foot test range is given in Figure 75 and respectively in Tables 32 and 33.

Processed MF swept-frequency data for flat -2 dB NIA taken over a 390-foot test range is given in Figure 76 with and without attenuation.

4.5 REDUCED DATA FROM MAGMA COPPER CO. SAN MANUEL MINE

MF and HF swept-frequency data characterizing monofilar mode coupling into a track over a 243-foot test range is given in Figure 77 and in Tables 34 and 35. Companion data illustrating monofilar track current

FIGURE 60

PROCESSED MF AND HF DATA FROM WAGNER AREA OF UNITED NUCLEAR SECTION 23 MINE AT 180 FOOT TEST RANGE FOR FLAT NIA OF -2 DB

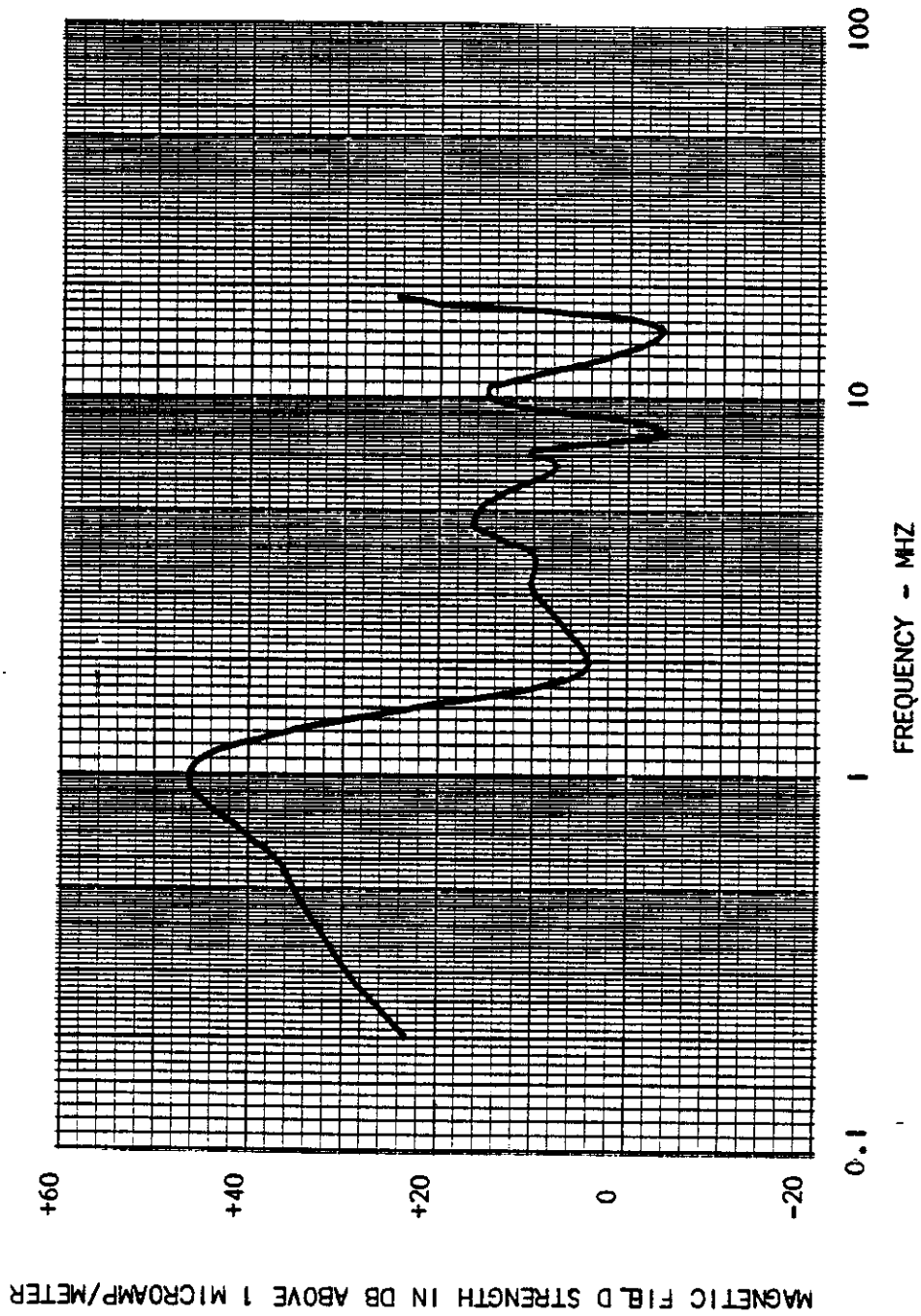

TABLE 21

SUMMARY OF CONDUCTOR ENSEMBLE IMPEDANCES DEDUCED FROM MEASUREMENTS
UNITED NUCLEAR SECTION 23 MINE

FREQ(MHZ)	WAGNER AREA TX PROBE 480 VAC LINE	WAGNER AREA TX ANTENNA 480 VAC LINE/WATER LINE	650 TRACK AREA TX PROBE PHONE LINE	650 TRACK AREA TX ANTENNA PHONELINE/POWER LINE
0.20	7395	-	-	-
0.25	2259	-	2506	17.5
0.35	601.1	349.9	1599	14.3
0.45	203.7	294.4	2037	14.3
0.55	151.0	341.9	1795	28.4
0.65	93.1	338.0	2624	40.2
0.75	93.1	201.3	6591	63.7
0.85	144.2	177.4	-	-
0.95	210.8	-	-	-

FIGURE 61
 KERR-MCGEE HOBBS POTASH FACILITY MINE
 AREA 140 -BT#3 MEDIUM FREQUENCY SWEPT
 FIELD STRENGTH MEASUREMENTS AT TWO FIXED
 RANGES - 1 WATT POWER INTO PRACTICAL
 MAN-PACK LOOP ANTENNA CHARACTERIZATION
 WITH CONDUCTORS PRESENT

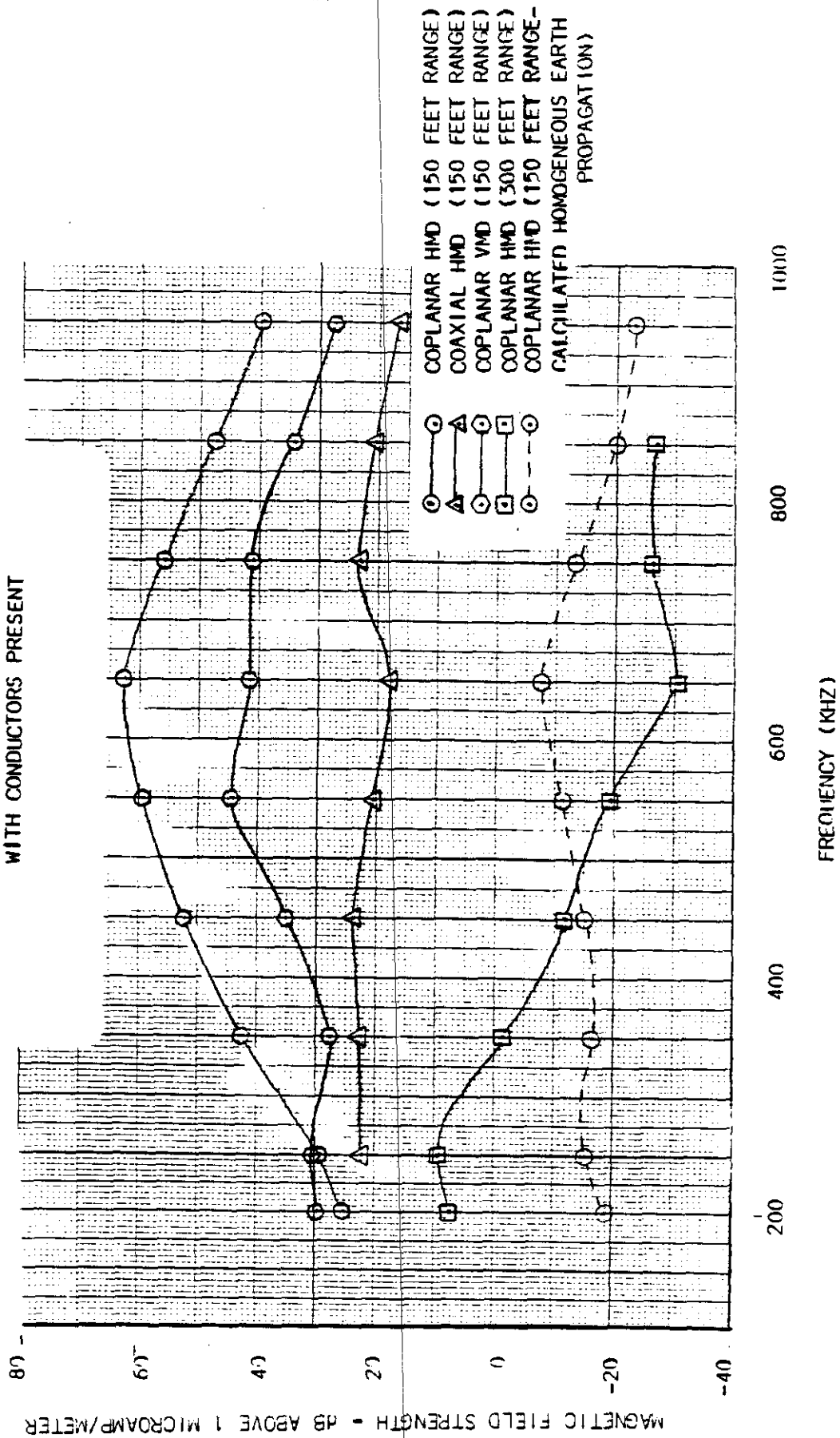

FIGURE 62
 KERR-MCGEE HOBBS POTASH FACILITY MINE
 AREA 140-BT#3 HIGH FREQUENCY SWEEP FIELD
 STRENGTH MEASUREMENTS AT 300 FEET RANGE
 1 WATT POWER INTO PRACTICAL MAN-PACK LOOP
 ANTENNA CHARACTERIZATION WITH CONDUCTORS
 PRESENT

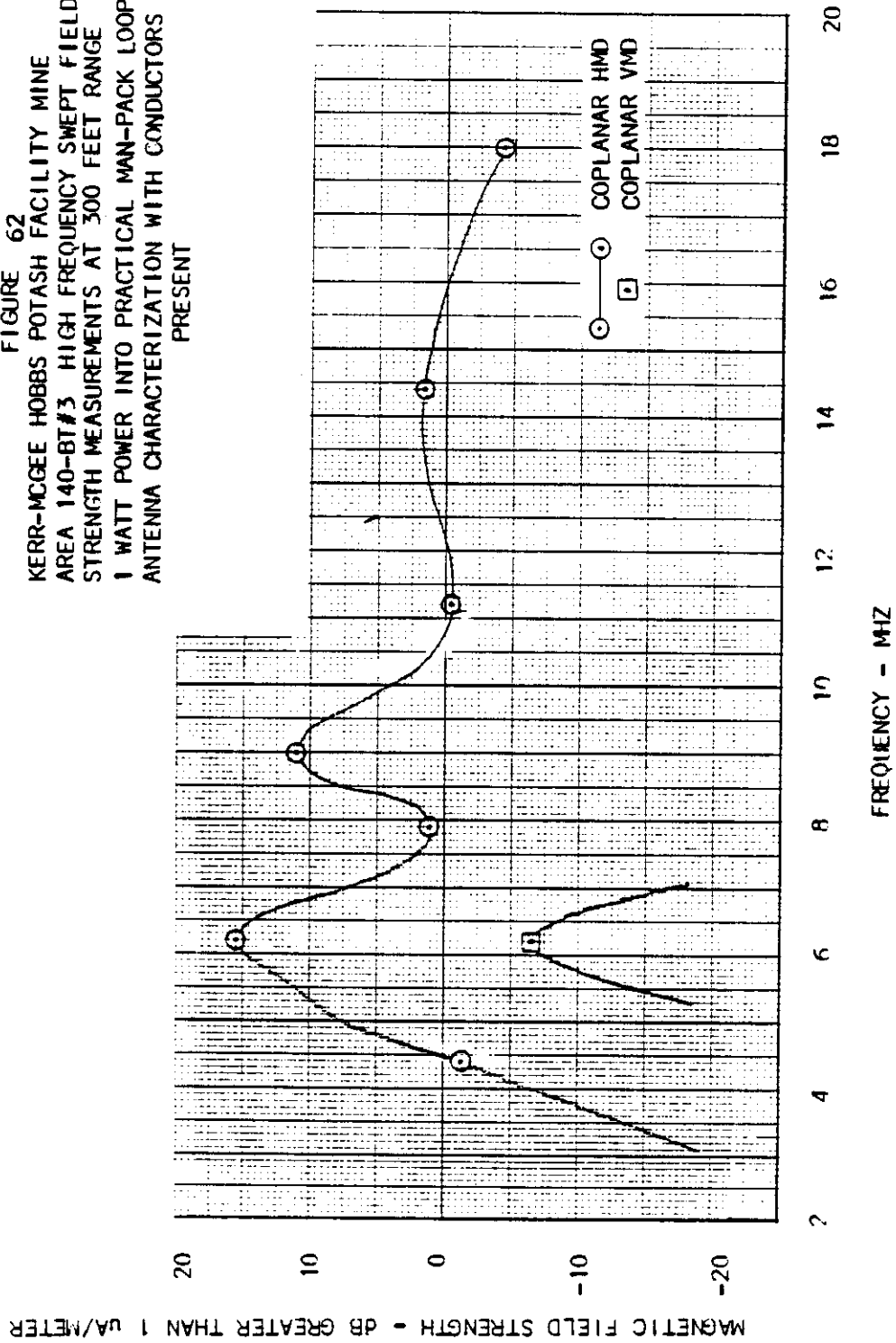
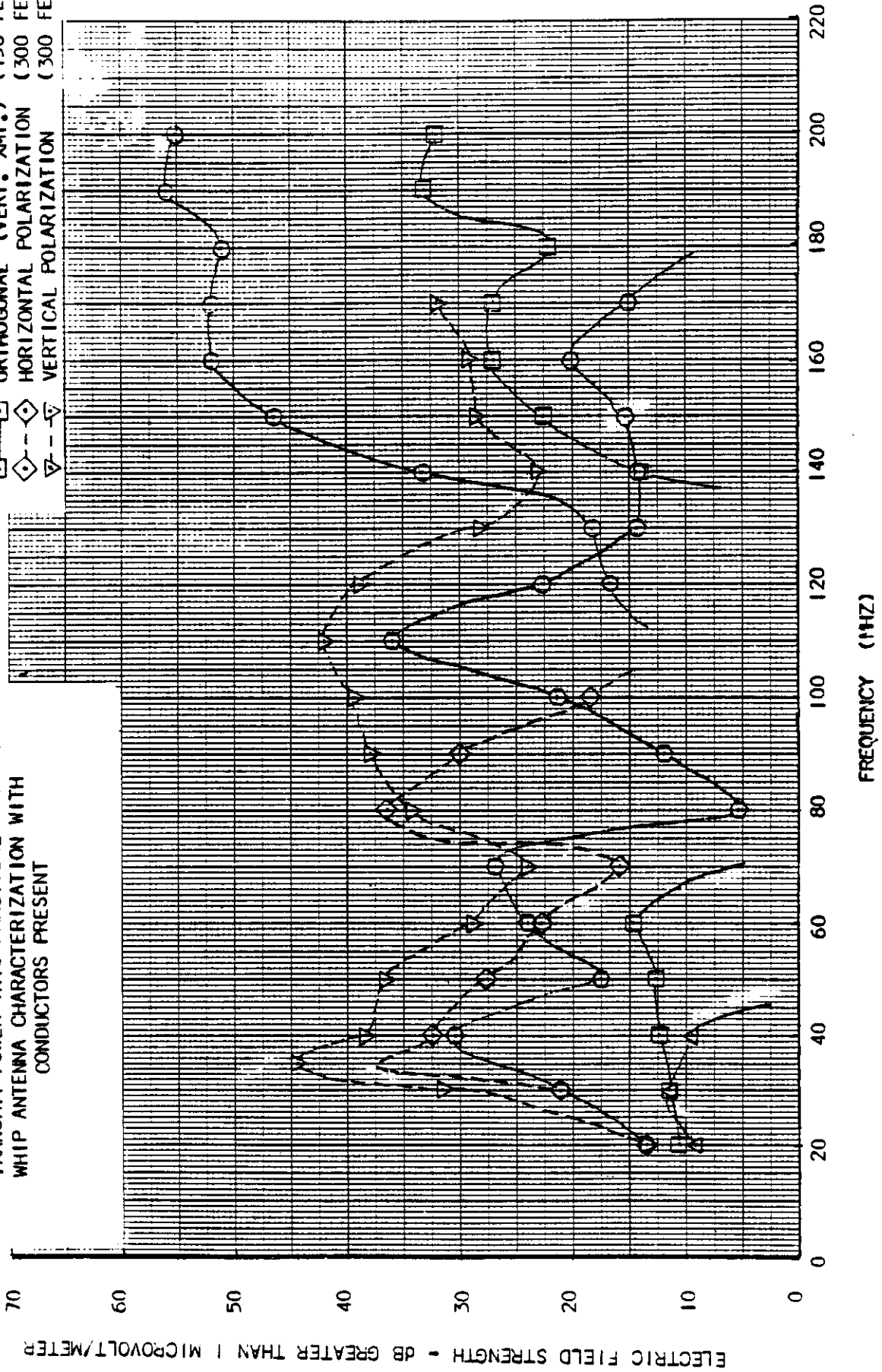

FIGURE 63

KERR-MCGEE HOBBS POTASH FACILITY MINE
 AREA 140 - BT#3 VHF SWEPT FIELD STRENGTH
 MEASUREMENTS AT TWO FIXED RANGES
 TRANSMIT POWER INTO PRACTICAL MAN-PACK
 WHIP ANTENNA CHARACTERIZATION WITH
 CONDUCTORS PRESENT

	ANTENNA ORIENTATIONS	RANGE
○—○	HORIZONTAL POLARIZATION	(150 FEET)
○—○	VERTICAL POLARIZATION	(150 FEET)
△—△	COAXIAL	(150 FEET)
□—□	ORTHOGONAL (VERT. XMT.)	(150 FEET)
◇—◇	HORIZONTAL POLARIZATION	(300 FEET)
▽—▽	VERTICAL POLARIZATION	(300 FEET)



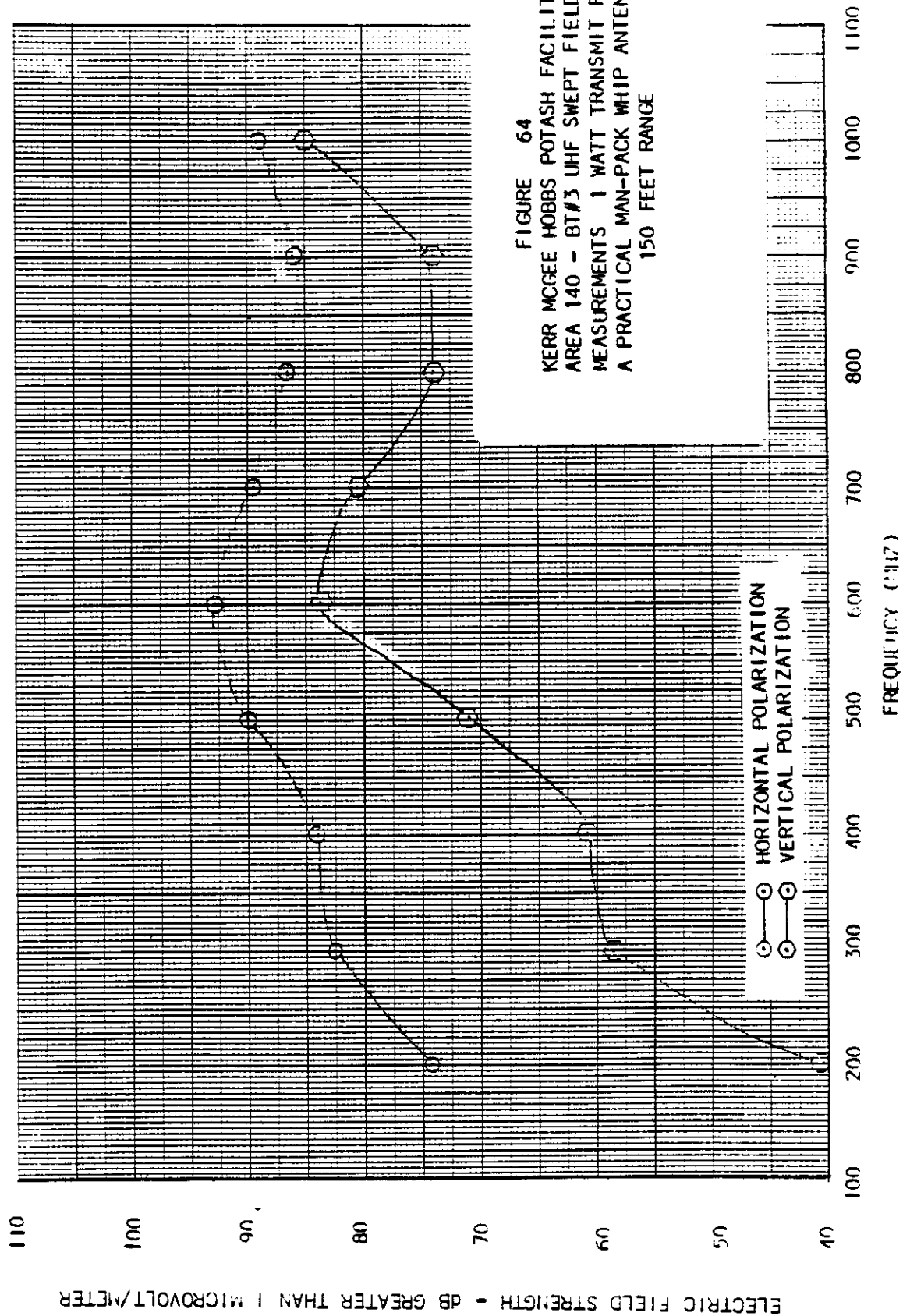

FIGURE 64
 KERR MCGEE HOBBS POTASH FACILITY MINE
 AREA 140 - BT#3 UHF SWEEP FIELD STRENGTH
 MEASUREMENTS 1 WATT TRANSMIT POWER INTO
 A PRACTICAL MAN-PACK WHIP ANTENNA
 150 FEET RANGE

ELECTRIC FIELD STRENGTH - DB GREATER THAN 1 MICROVOLT/METER

FIGURE 65
 CURRENT PROBE MEDIUM FREQUENCY FIELD
 STRENGTH MEASUREMENTS AT 300 FEET RANGE
 KERR-MCREE HOBBS POTASH FACILITY MINE
 AREA 140- BT#3 INCLUDING BOTH EMPIRICAL AND
 THEORETICAL DATA

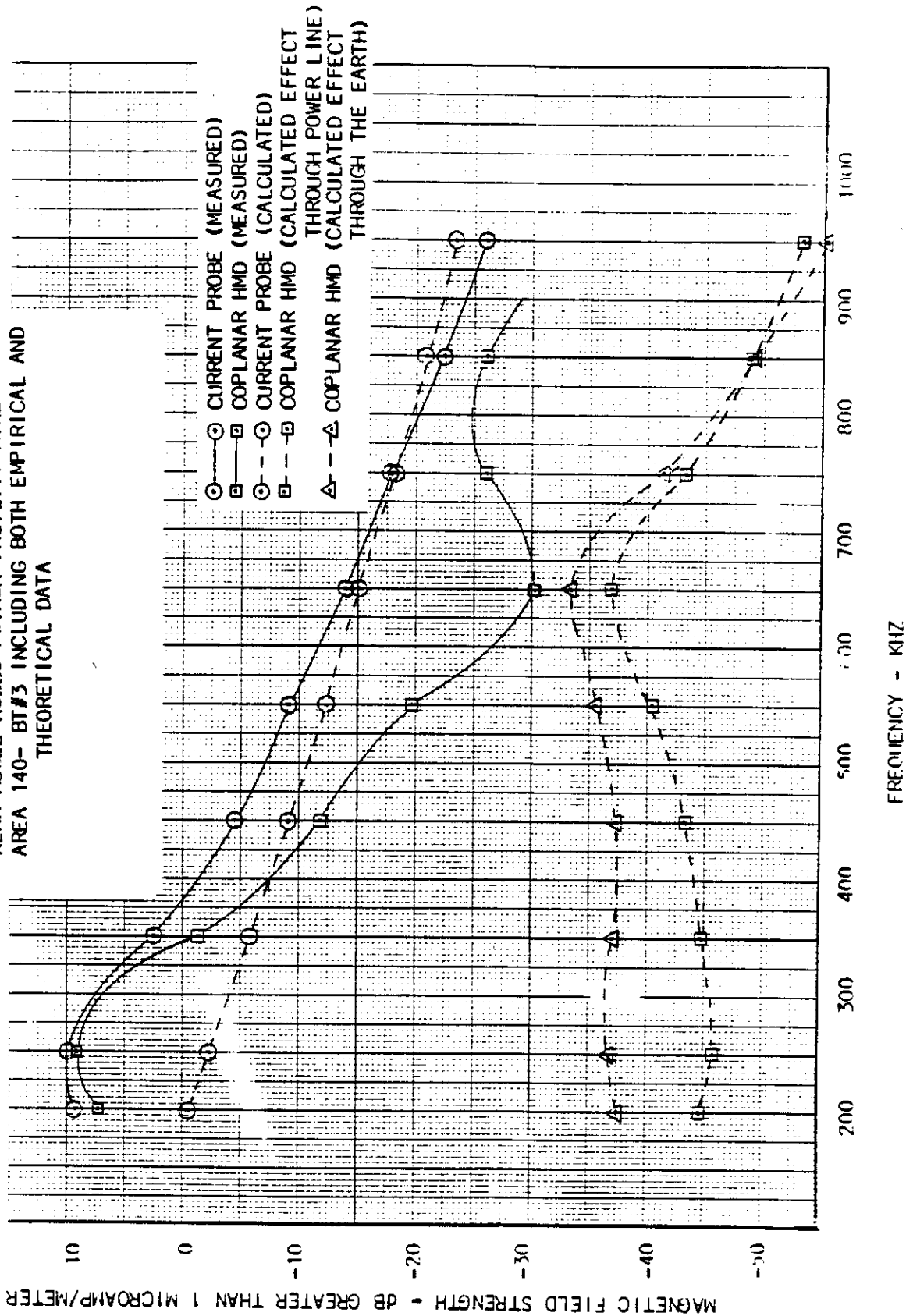

FIGURE 66
KERR-MCGEE HOBBS POTASH FACILITY MINE
AREA 140 - BT#3 MEDIUM FREQUENCY CONTINUOUS
WAVE FIELD STRENGTH MEASUREMENTS VS. RANGE
1 WATT POWER INTO PRACTICAL MAN-PACK LOOP
ANTENNAS WITH CONDUCTOR ENHANCEMENT 250KHZ,
650KHZ AND 950KHZ

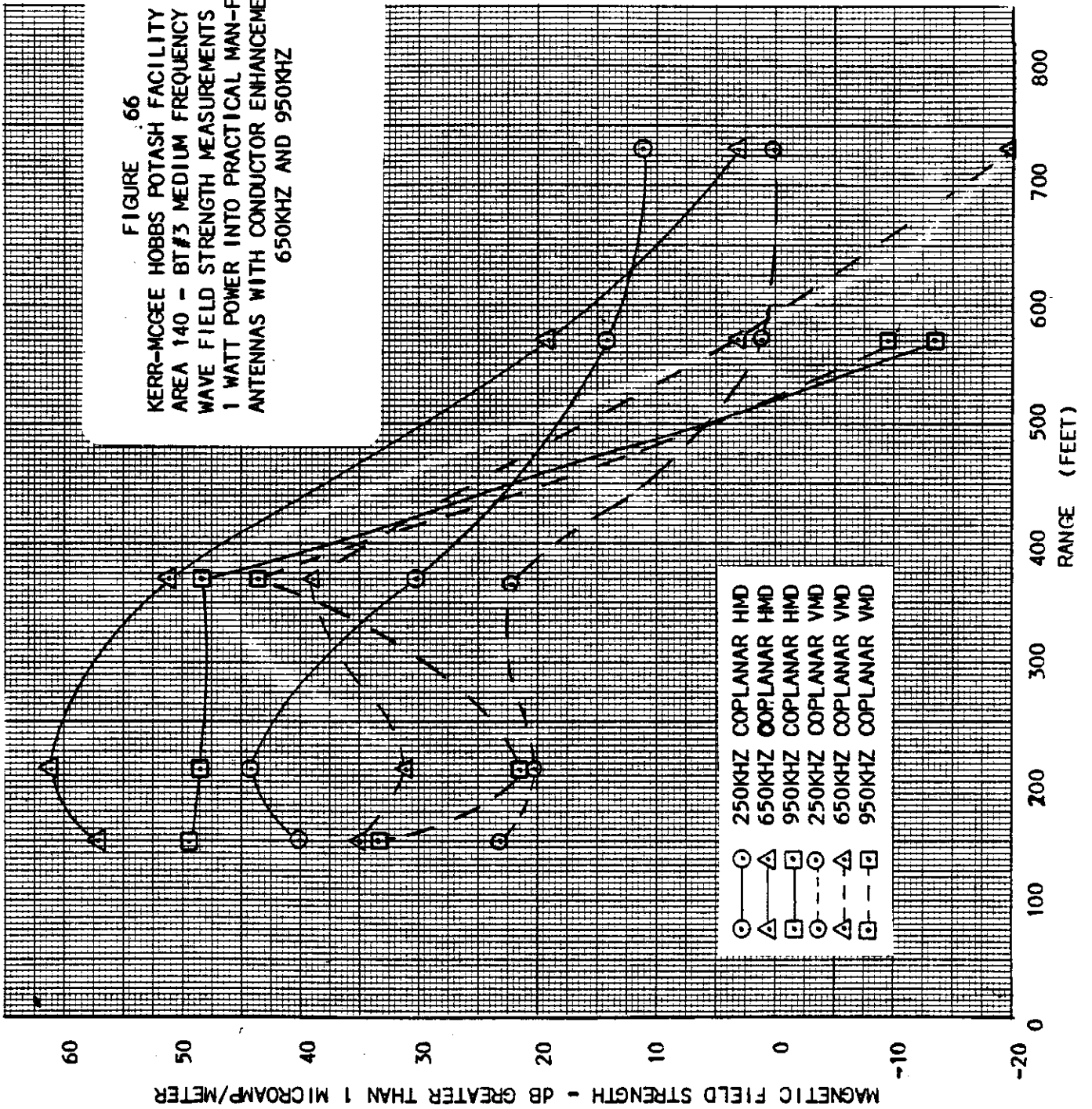

TABLE 22
 MEDIUM FREQUENCY CONTINUOUS WAVE FIELD STRENGTH MEASUREMENT
 DATA KERR-MCGEE HOBBS POTASH FACILITY MINE AREA 140-BT #3
 1 WATT TRANSMIT POWER

COPLANAR HMD MEASUREMENTS (IN dB GREATER THAN 1 μ V)

<u>LOCATION #</u>	<u>DISTANCE (FEET)</u>	<u>250 KHZ</u>	<u>650 KHZ</u>	<u>950 KHZ</u>
1	150	32	66	51
2	210	36	70	50
3	370	22	60	50
4	570	6	28	-12
5	730	3	12	NOISE

COPLANAR VMD MEASUREMENTS (IN dB GREATER THAN 1 μ V)

<u>LOCATION #</u>	<u>DISTANCE (FEET)</u>	<u>250 KHZ</u>	<u>650 KHZ</u>	<u>950 KHZ</u>
1	150	15	44	35
2	210	12	40	23
3	370	14	48	45
4	570	-7	12	-8
5	730	-8	-11	NOISE

FIGURE 67
KERR-MCGEE HOBBS POTASH FACILITY MINE 650KHZ
CONDUCTOR ENHANCED FIELD STRENGTH MEASUREMENT
DATA 1 WATT TRANSMIT POWER INTO PRACTICAL
VEHICULAR ANTENNA CHARACTERIZATION (INA=0.82)
(SEE FIGURE 27 FOR TEST LOCATIONS)

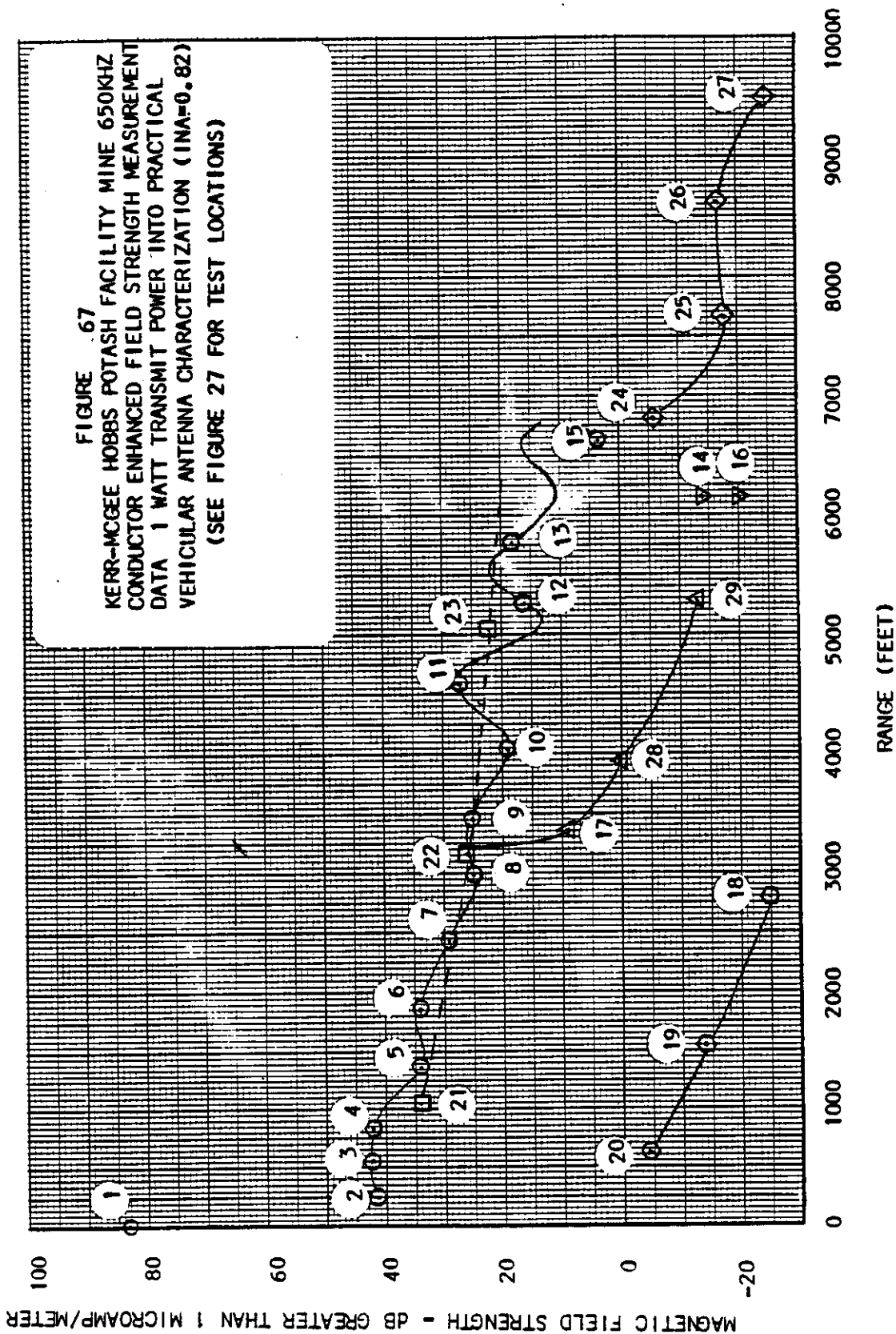

TABLE 23

CONDUCTOR-ENHANCED MEDIUM FREQUENCY CONTINUOUS
 WAVE FIELD STRENGTH MEASUREMENTS - KERR MCGEE
 HOBBS POTASH FACILITY * 650 KHZ TEST FREQUENCY
 1 WATT TRANSMIT POWER

<u>LOCATION #</u>	<u>FEET RANGE</u>	<u>DISTANCE FROM CONDUCTORS-METERS</u>	<u>READING (dB ABOVE 1 μV)</u>
1	10	0.6	92
2	250	0.6	50
3	550	0.6	51
4	820	0.6	51
5	1370	0.6	43
6	1850	0.6	43
7	2420	0.6	38
8	2980	0.6	34
9	3450	0.6	34
10	4030	0.6	28
11	4580	0.6	36
12	5260	0.6	25
13	5760	0.6	27
14	6160	UNKNOWN	-5
15	6620	2	12
16	6160	UNKNOWN	-11
17	3340	0.6	18
18	2800	40	-16
19	1550	40	-5
20	620	40	4.5
21	1050	0.6	43
22	3150	0.6	35
23	5040	0.6	31
24	6800	0.6	-6.4
25	7650	0.6	-9
26	8610	0.6	-8
27	9490	0.6	-1
28	3925	0.6	9
29	5270	0.6	-4

* SEE FIGURE 27 FOR TEST LOCATIONS

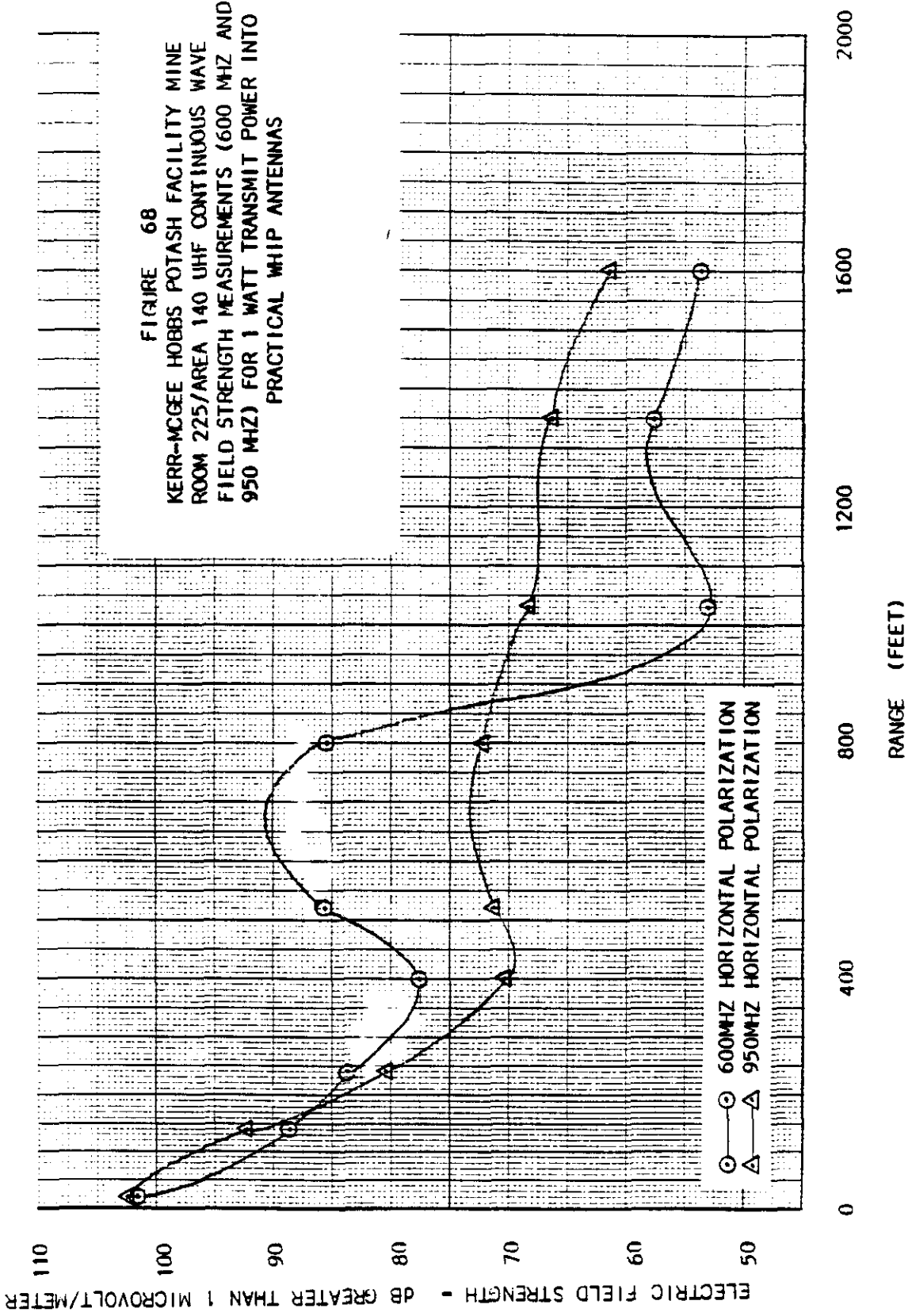

TABLE 24
 UHF CONTINUOUS WAVE FIELD STRENGTH MEASUREMENT DATA
 KERR-MCGEE HOBBS POTASH FACILITY MINE ROOM 225
 (HORIZONTAL ANTENNA POLARIZATION)
 1 WATT TRANSMIT POWER

<u>LOCATION #</u>	<u>DISTANCE (FEET)</u>	<u>(IN dB ABOVE 1 μV)</u>	
		<u>600 MHZ</u>	<u>950 MHZ</u>
1	20	64	60
2	140	51	50
3	240	46	38
4	400	40	28
5	520	48	29
6	800	48	30
7	1030	15.5	26
8	1350	20	24
9	1600	16	19

TABLE 25
 MICROWAVE FREQUENCY CONTINUOUS WAVE FIELD STRENGTH
 MEASUREMENT DATA KERR-MCGEE HOBBS POTASH FACILITY
 ROOM 27 WEST (1 WATT TRANSMIT POWER- 10 GHZ)

<u>LOCATION#</u>	<u>DESCRIPTION</u>	<u>DISTANCE (FEET)</u>	<u>READING (dB)</u>
1	BT 12 East Edge	2	34/40 scale
2	BT 12 West Edge	30	42/ 0 scale
3	BT 13 West Edge	105	39/ 0 scale
4	BT 14 West Edge	180	37.5/ 0 scale
5	BT 14 15' South of Reflector	195	39.5/ 0 scale

FIGURE 69

PROCESSED MF AND HF DATA FROM KERR-MCGEE POTASH MINE ON 150-FOOT TEST RANGE FOR FLAT NIA OF -2 DB WITH AND WITHOUT ATTENUATION

MAGNETIC FIELD STRENGTH IN DB ABOVE 1 MICRAMP/METER

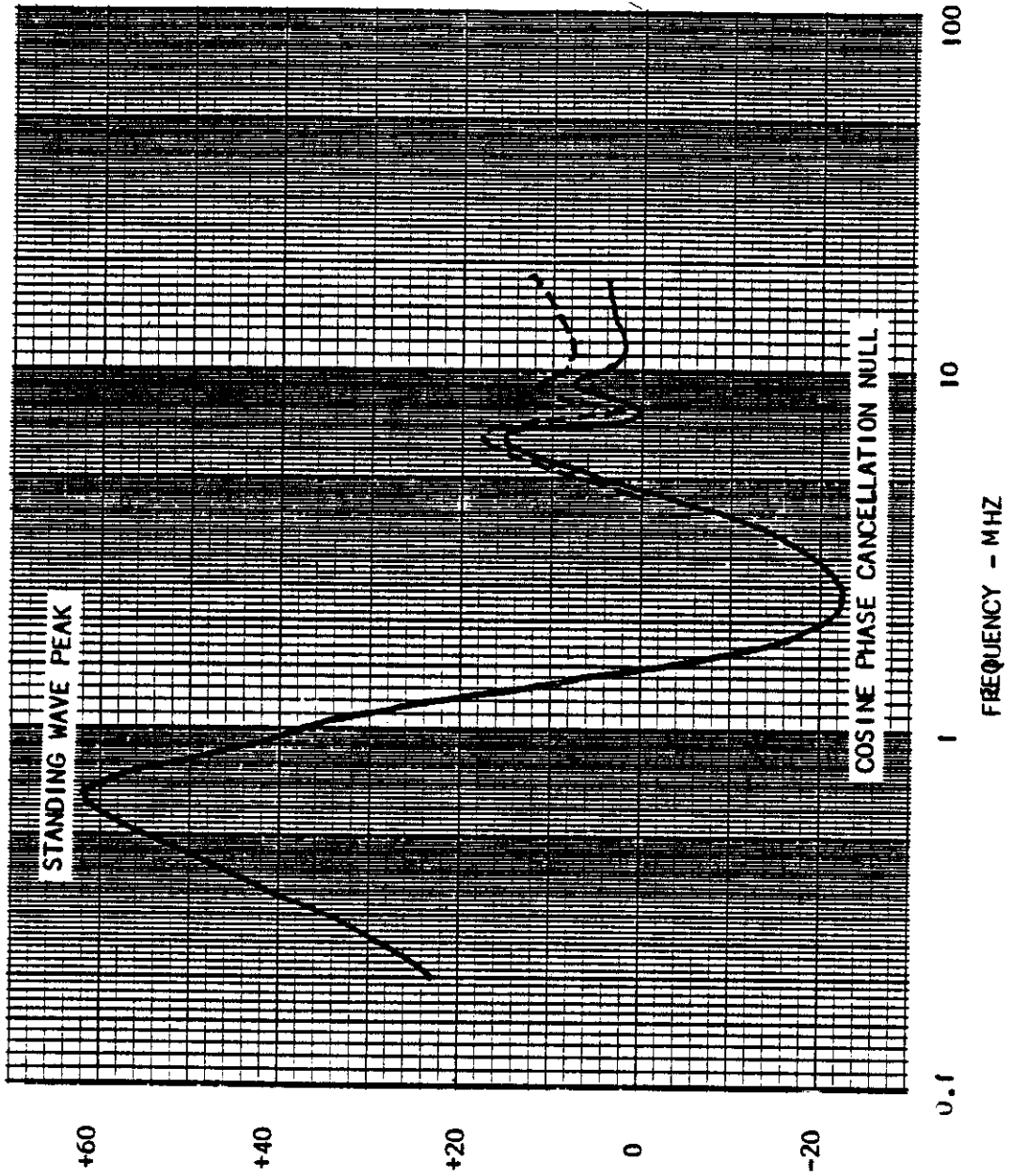

FIGURE 70

MAGNETIC FIELD STRENGTH VS RANGE ALONG
 NORTH MINE TRACKED HAULAGEWAY FOR 1-WATT
 TRANSMITTER LOOP-COUPLED INTO DEDICATED
 WIRE @ 50-450 KHZ AMAX LEAD CO. BUICK MINE

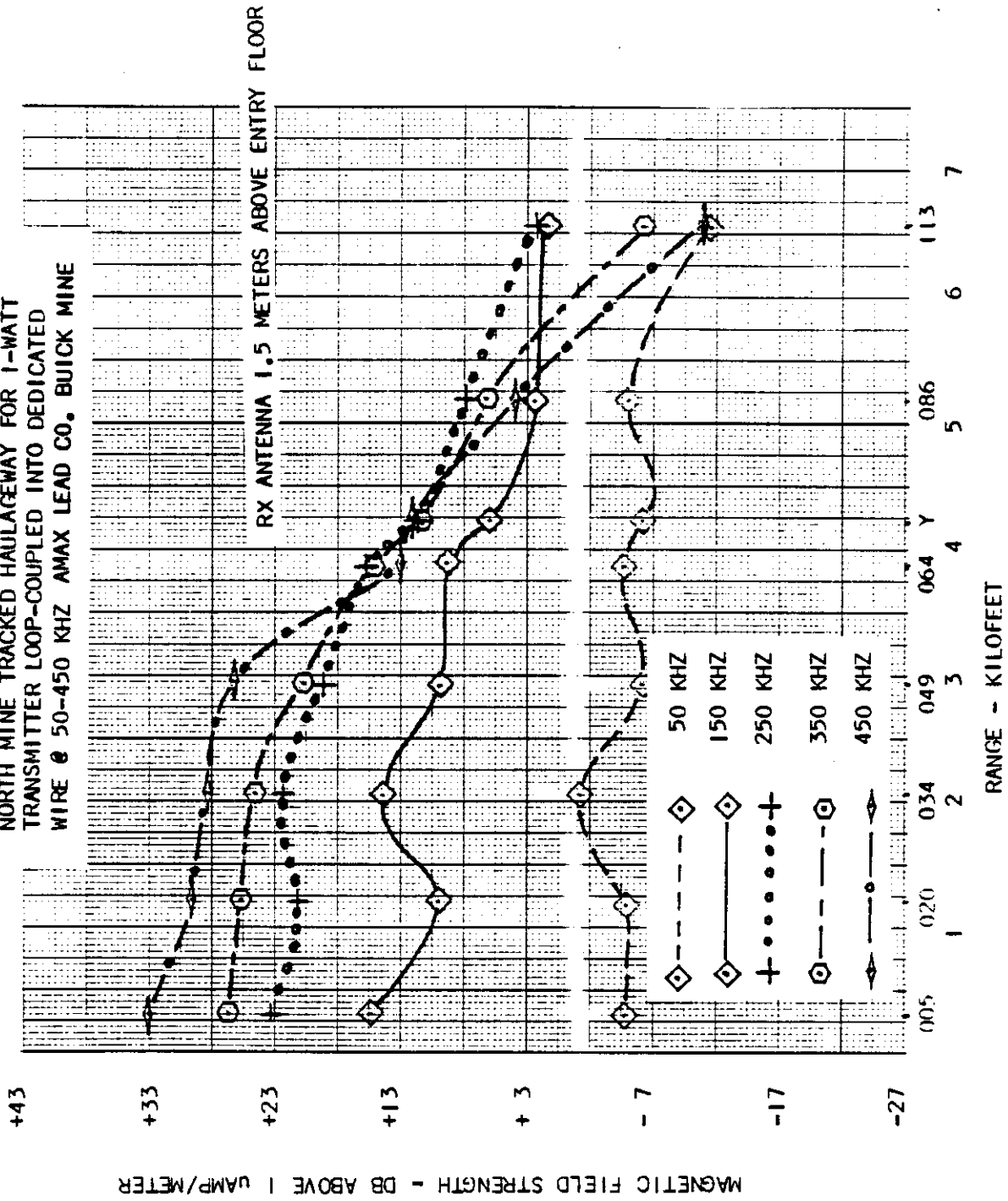

FIGURE 71

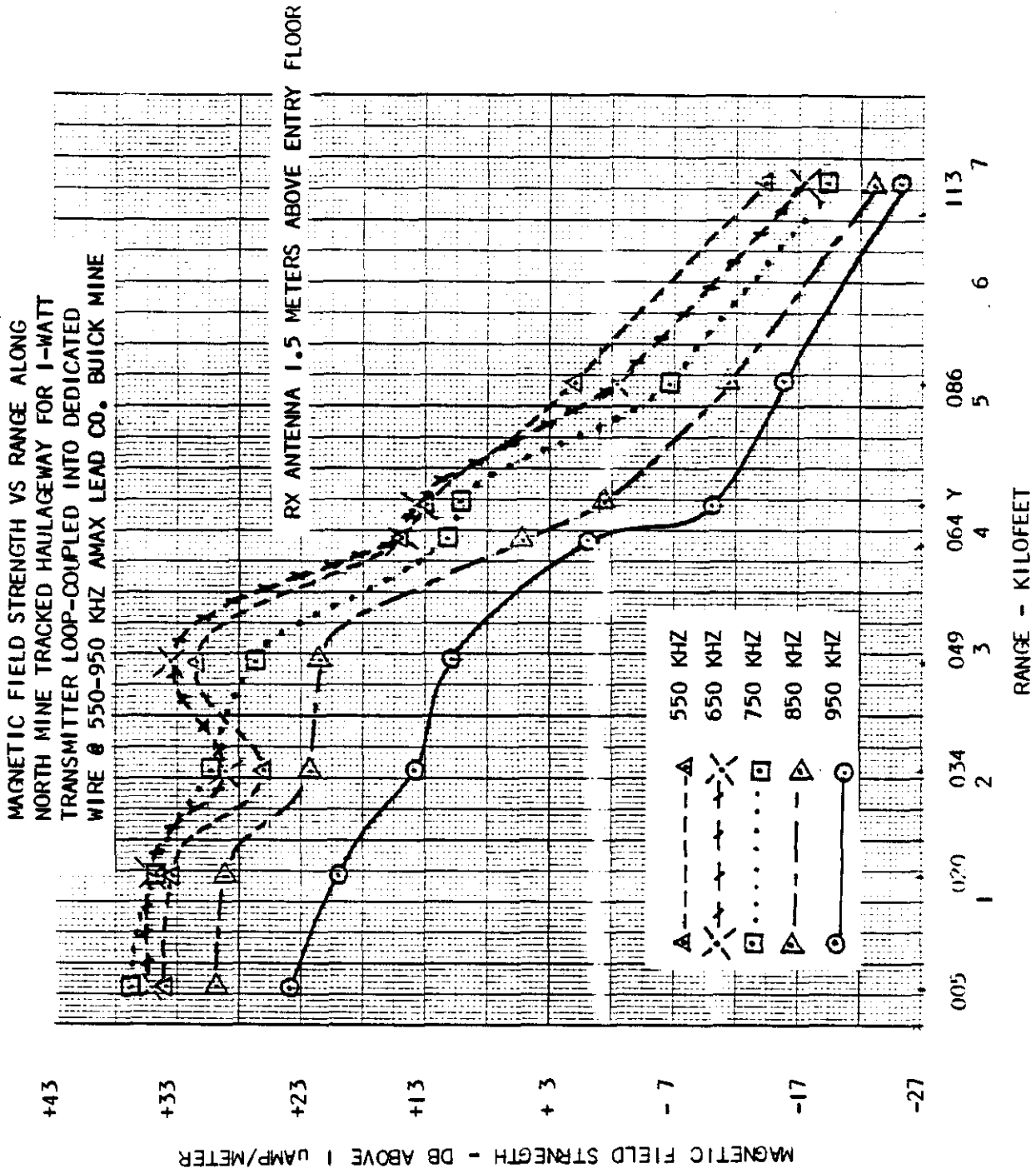

TABLE 26

REDUCED MAGNETIC FIELD STRENGTH DATA TAKEN ON A SWEEP-FREQUENCY BASIS WITH RANGE ALONG THE NORTH MINE TRACKED HAULAGE DRIFT AWAY FROM A 1-WATT TRANSMITTER LOOP-COUPLED INTO THE DEDICATED WIRE IN THE FOREMAN'S SHACK AMAX LEAD CO. BUICK MINE

FREQUENCY (MHZ)	STATION 005		SCOPE	STATION 020		SCOPE
	H DB ABOVE	1 μ A/M	DBM	H DB ABOVE	1 μ A/M	DBM
0.05	- 4.6		-74.5	- 4.6		-74.5
0.15	+15.5		-54.0	+10.0		-59.5
0.25	+23.2		-46.5	+21.2		-48.5
0.35	+26.9		-42.5	+25.9		-43.5
0.45	+33.0		-35.5	+29.5		-39.0
0.55	+34.0		-33.0	+33.5		-33.5
0.65	+35.1		-30.0	+35.1		-30.0
0.75	+36.8		-26.5	+34.8		-28.5
0.85	+29.7		-31.0	+29.2		-31.5
0.95	+24.0		-35.0	+20.0		-39.0
FREQUENCY (MHZ)	STATION 034		SCOPE	STATION 049		SCOPE
	H DB ABOVE	1 μ A/M	DBM	H DB ABOVE	1 μ A/M	DBM
0.05	- 1.0		-70.5	- 6.0		-75.5
0.15	+14.5		-53.0	+10.0		-59.5
0.25	+22.2		-47.5	+19.2		-50.5
0.35	+24.9		-44.5	+20.9		-48.5
0.45	+28.5		-40.0	+26.5		-42.0
0.55	+26.0		-41.0	+31.5		-35.5
0.65	+29.1		-36.0	+33.6		-31.5
0.75	+30.3		-33.0	+31.8		-31.5
0.85	+22.2		-38.5	+21.7		-39.0
0.95	+14.0		-45.0	+11.0		-48.0

TABLE 26 CONT.

FREQUENCY (MHZ)	STATION 064		SCOPE	STATION @ Y		SCOPE
	H DB ABOVE	μ A/M	DBM	H DB ABOVE	μ A/M	DBM
0.05	- 4.5		-74.0	- 6.0		-75.5
0.15	+ 9.5		-60.0	+ 6.0		-63.5
0.25	+15.7		-54.0	+11.7		-58.0
0.35	+15.4		-54.0	+11.4		-58.0
0.45	+13.0		-55.5	+12 .0		-56.5
0.55	+15.0		-52.0	+13.0		-54.0
0.65	+15.1		-50.0	+13.6		-51.5
0.75	+11.3		-52.0	+10.3		-53.0
0.85	+ 5.2		-55.5	- 1.3		-62.0
0.95	0		-59.0	-10.0		-69.0
FREQUENCY (MHZ)	STATION 086		SCOPE	STATION 113		SCOPE
	H DB ABOVE	μ A/M	DBM	H DB ABOVE	μ A/M	DBM
0.05	- 5.0		-74.5	-11.5		-81.0
0.15	+ 2.5		-67.0	+ 1.5		-68.0
0.25	+ 7.7		-62.0	+ 1.7		-68.0
0.35	+ 6.4		-63.0	- 6.1		-75.5
0.45	+ 4.0		-64.5	-11.0		-79.0
0.55	+ 1.0		-66.0	-14.0		-81.0
0.65	- 2.4		-67.5	-17.4		-82.5
0.75	- 6.7		-70.0	-20.2		-83.5
0.85	-11.3		-72.0	-23.0		-83.7
0.95	-15.5		-74.5	-25.0		-84.0

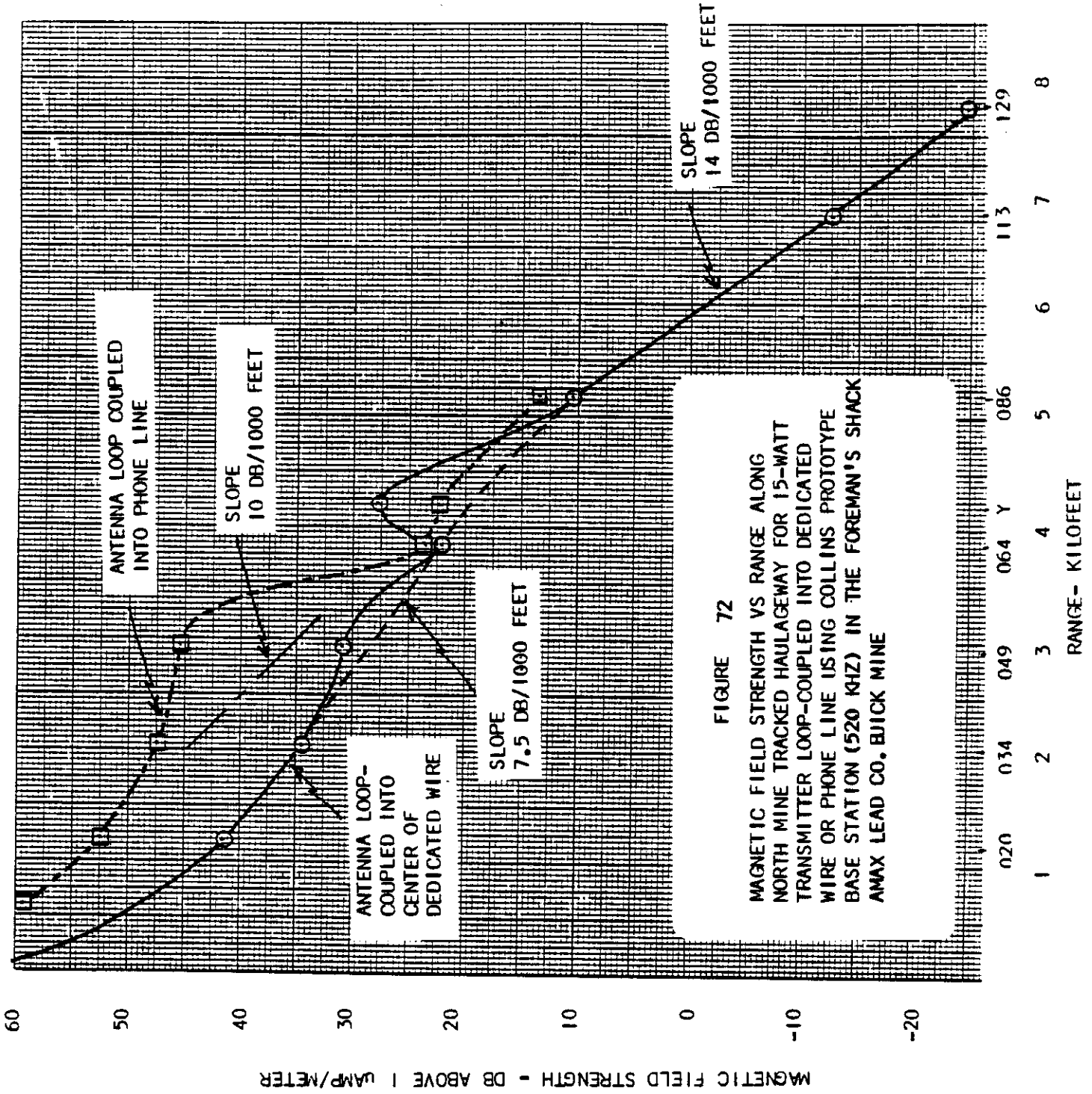

TABLE 27

RESULTS OF MF CW DEMONSTRATION TESTING AT 520 KHZ USING COLLINS PROTOTYPE BASE STATION AS THE TRANSMITTER IN THE FORMAN'S SHACK AND USING A SINGER FIELD STRENGTH METER PLUS A PORTABLE COLLINS UNIT ALONG THE NORTH MINE TRACKED HAULAGE DRIFT AMAX LEAD CO. BUICK MINE

LOCATION	LOOP-COUPLED TO DEDICATED WIRE		LOOP-COUPLED TO PHONE LINE	
	SINGER READINGS	H DB ABOVE 1 μ A/M	SINGER READINGS	H DB ABOVE 1 μ A/
002	+ 8 on +60	+61.5		
020	+ 8 on +40	+41.5	+19 on +40	+52.5
034	+ 1 on +40	+34.5	+14 on +40	+47.5
049	+17½ on +20	+31.0	+12 on +40	+45.5
064	+ 8½ on +20	+22.0	+10 on +20	+23.0
Y	+14½ on +20	+28.0	+ 9 on +20	+22.5
086	+17 on 0	+10.5	0 on +20	+13.5
113	+14 on -20	-12.5		
129	+ 2 on -20	-24.5		
141	barely hear xmtr in noise			

NOTE: STATION 113 WAS FARTHEST AWAY THAT TWO-WAY COMMUNICATIONS COULD BE MAINTAINED (15 WATT BASE & 15 WATT PORTABLE)
 @ STATION 129, PORTABLE-BASE LINKAGE WAS LOST BUT BASE-PORTABLE LINKAGE WAS STILL COPYABLE.

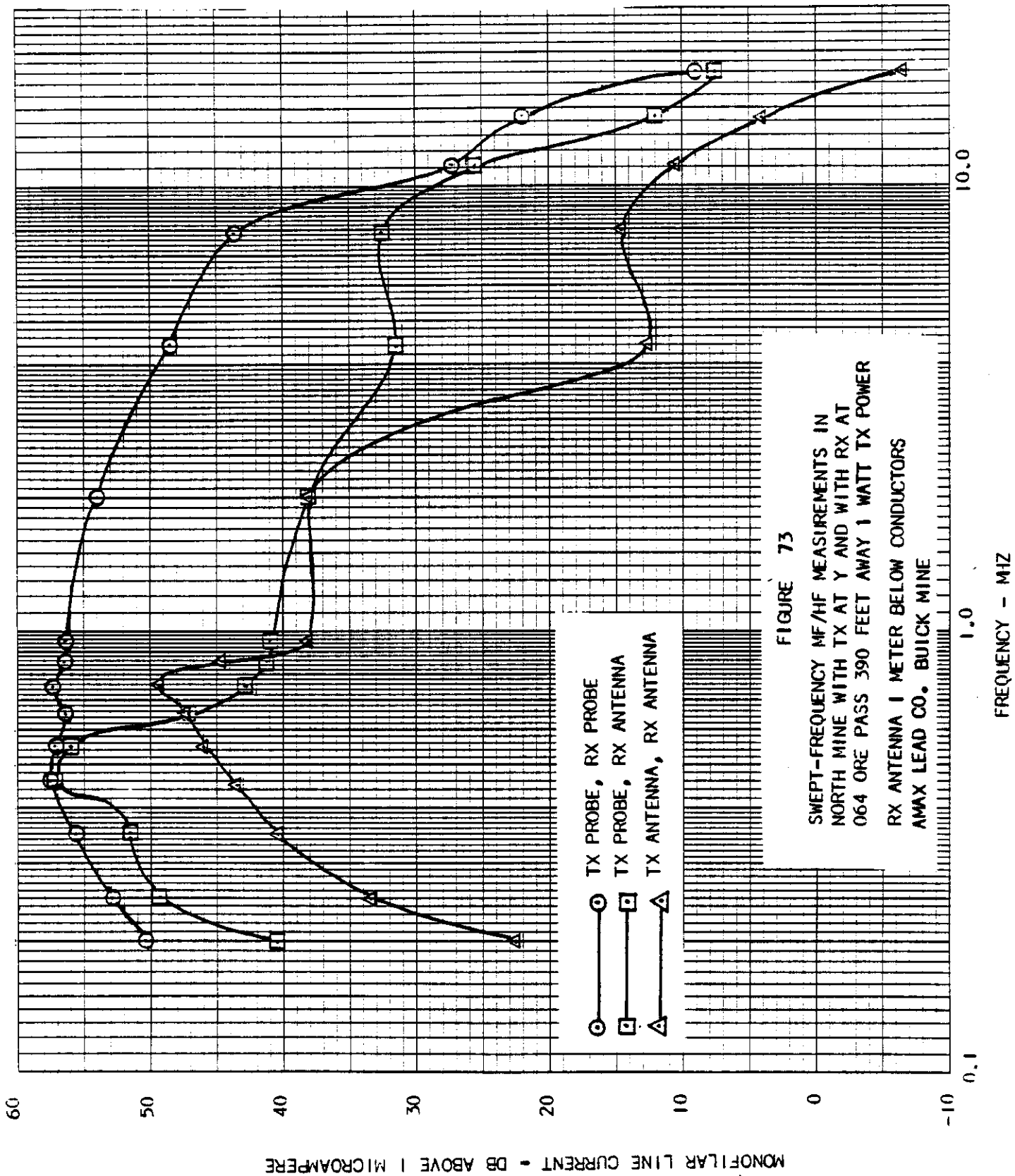

TABLE 28

REDUCED MAGNETIC FIELD STRENGTH AND COUPLED CURRENT MF DATA
 TAKEN ON A SWEEP-FREQUENCY BASIS AT 064 ORE PASS FROM A 1 WATT
 TRANSMITTER LOCATED AT THE NORTHWEST/NORTHEAST Y AMAX LEAD CO.

— BUICK MINE —

FREQUENCY (MHZ)	TX PROBE-RX PROBE		TX PROBE-RX ANTENNA		
	DBM	I IN DB ABOVE 1 μ A	DBM	H (DB ABOVE 1 μ A/M)	I (DB ABOVE 1
0.20	-14.0	+50.5	-45.0	+24.5	+40.5
0.25	-11.0	+53.0	-36.5	+33.2	+49.2
0.35	- 6.5	+55.9	-34.0	+35.4	+51.4
0.45	- 4.0	+57.8	-27.0	+41.5	+57.5
0.55	- 4.0	+57.3	-27.0	+40.0	+56.0
0.65	- 4.5	+56.5	-34.0	+31.1	+47.1
0.75	- 3.5	+57.3	-36.5	+26.8	+42.8
0.85	- 4.0	+56.6	-35.5	+25.2	+41.2
0.95	- 4.0	+56.5	-34.0	+25.0	+41.0

FREQUENCY (MHZ)	TX ANTENNA-RX ANTENNA		
	DBM	H (DB ABOVE 1 μ A/M)	I (DB ABOVE 1 μ A)
0.20	-63.0	+ 6.5	+22.5
0.25	-52.0	+17.7	+33.7
0.35	-45.0	+24.4	+40.4
0.45	-41.0	+27.5	+43.5
0.55	-37.0	+30.0	+46.0
0.65	-33.5	+31.6	+47.6
0.75	-30.0	+33.3	+49.3
0.85	-32.0	+28.7	+44.7
0.95	-37.0	+22.0	+38.0

CURRENT CALCULATED ASSUMING 1-METER RADIUS FROM CONDUCTORS

TABLE 29

REDUCED MAGNETIC FIELD STRENGTH AND COUPLED CURRENT MF DATA
 TAKEN ON A SWEEP-FREQUENCY BASIS AT 064 ORE PASS FROM A 1 WATT
 TRANSMITTER LOCATED AT THE NORTHWEST/NORTHEAST Y AMAX LEAD CO.

BUICK MINE

FREQUENCY(MHZ)	TX PROBE-RX PROBE		TX PROBE-RX ANTENNA		
	DBM	I IN DB ABOVE 1 μ A	DBM	H(DB ABOVE 1 μ A/M)	I(DB ABOVE 1
2.0	-6.0	+54.0	-40.0	+22.0	+38.0
4.4	-11.0	+48.5	-37.0	+15.4	+31.4
7.9	-15.5	+43.7	-35.0	+16.6	+32.6
11.2	-32.0	+27.1	-41.0	+9.7	+25.7
14.4	-40.0	+19.0	-54.0	-4.0	+12.0
18.0	-50.0	+9.0	-58.0	-8.3	+7.7

FREQUENCY(MHZ)	TX ANTENNA-RX ANTENNA		
	DBM	H(DB ABOVE 1 μ A/M)	I(DB ABOVE 1 μ A)
2.0	-40.0	+22.0	+38.0
4.4	-55.0	-3.1	+12.9
7.9	-53.0	-1.4	+14.6
11.2	-56.0	-5.3	+10.7
14.4	-62.0	-12.0	+4.0
18.0	-72.0	-22.3	-6.3

CURRENT CALCULATED ASSUMING 1-METER RADIUS FROM CONDUCTORS

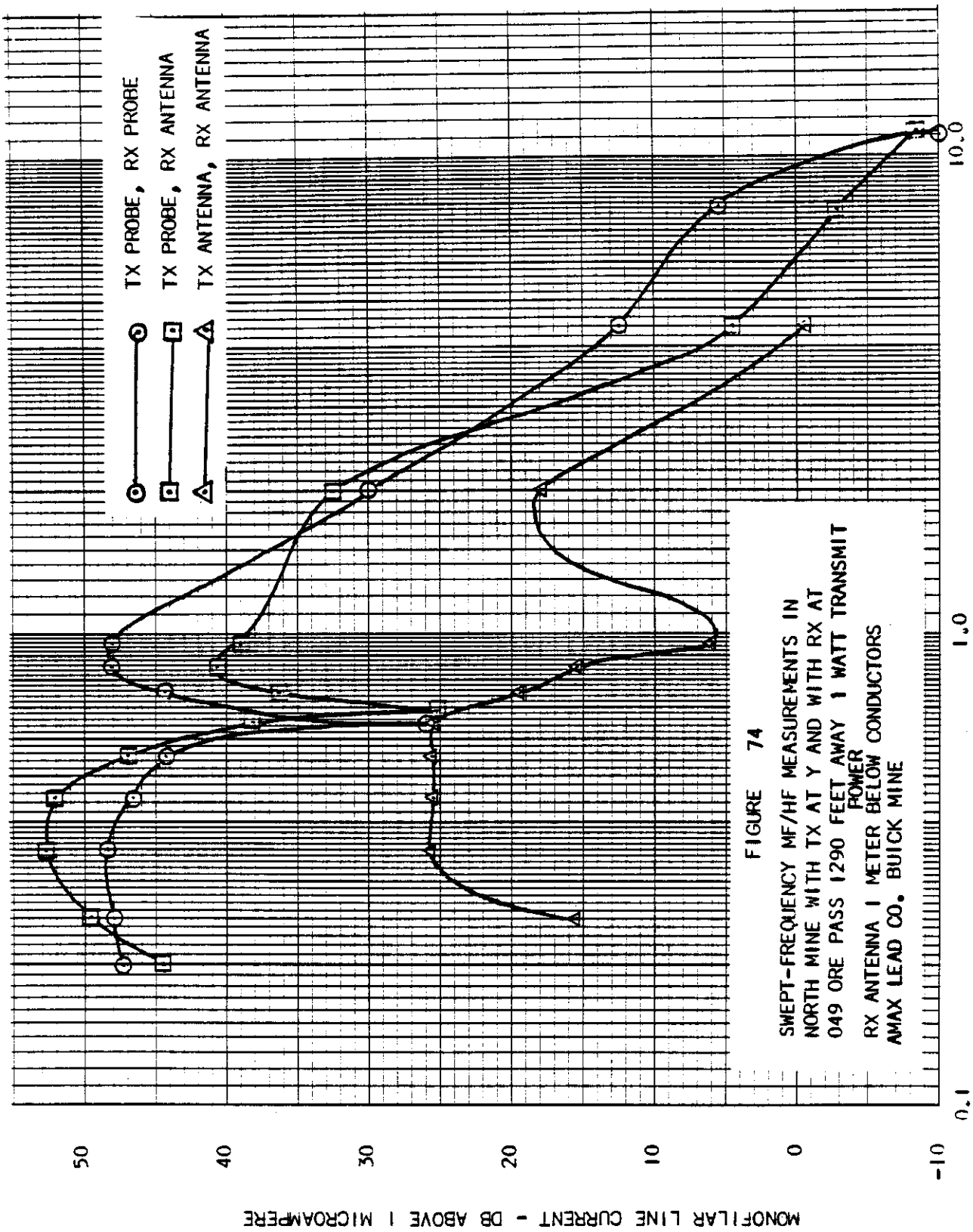

FIGURE 74

SWEPT-FREQUENCY MF/HF MEASUREMENTS IN
 NORTH MINE WITH TX AT Y AND WITH RX AT
 049 ORE PASS 1290 FEET AWAY 1 WATT TRANSMIT
 POWER
 RX ANTENNA 1 METER BELOW CONDUCTORS
 AMAX LEAD CO. BUICK MINE

TABLE 30

REDUCED MAGNETIC FIELD STRENGTH AND COUPLED CURRENT MF DATA
 TAKEN ON A SWEEP-FREQUENCY BASIS AT 049 ORE PASS FROM A 1 WATT
 TRANSMITTER LOCATED AT THE NORTHWEST/NORTHEAST Y
 AMAX LEAD CO. - BUICK MINE

FREQUENCY(MHZ)	TX PROBE-RX PROBE		TX PROBE-RX ANTENNA		
	DBM	I IN DB ABOVE 1 μ A	DBM	H(DB ABOVE 1 μ A/M)	I(DB ABOVE 1
0.20	-17.0	+47.5	-41.0	+28.5	+44.5
0.25	-16.0	+48.0	-36.0	+33.7	+49.7
0.35	-14.0	+48.4	-32.5	+36.9	+52.9
0.45	-15.0	+46.8	-32.5	+36.0	+52.0
0.55	-17.0	+44.3	-36.0	+31.0	+47.0
0.65	-35.0	+26.0	-43.0	+22.1	+38.1
0.75	-17.0	+43.8	-42.0	+21.3	+36.3
0.85	-12.5	+48.1	-36.0	+24.7	+40.7
0.95	-12.5	+48.0	-36.0	+25.0	+39.0

FREQUENCY(MHZ)	TX ANTENNA-RX ANTENNA		
	DBM	H(DB ABOVE 1 μ A/M)	I(DB ABOVE 1 μ A)
0.20	-	-	-
0.25	-70.0	- 0.3	+15.7
0.35	-60.0	+ 9.4	+25.4
0.45	-59.0	+ 9.5	+25.5
0.55	-57.5	+ 9.5	+25.5
0.65	-56.0	+ 9.1	+25.1
0.75	-60.0	+ 3.3	+19.3
0.85	-61.0	- 0.3	+15.7
0.95	-69.0	-10.0	+ 6.0

CURRENT CALCULATED ASSUMING 1-METER RADIUS FROM CONDUCTORS

TABLE 31

REDUCED MAGNETIC FIELD STRENGTH AND COUPLED CURRENT HF DATA
 TAKEN ON A SWEEP-FREQUENCY BASIS AT 049 ORE PASS FROM A 1 WATT
 TRANSMITTER LOCATED AT THE NORTHWEST/NORTHEAST Y
 AMAX LEAD CO. - BUICK MINE

FREQUENCY(MHZ)	TX PROBE-RX PROBE		TX PROBE-RX ANTENNA		
	DBM	I IN DB ABOVE 1 μ A	DBM	H(DB ABOVE 1 μ A/M)	I(DB ABOVE 1
2.0	-30.0	+30.0	-45.5	+16.5	+32.5
4.4	-47.0	+12.5	-64.0	-11.6	+ 4.4
7.9	-54.0	+ 5.2	-70.0	-18.4	- 2.4
11.2	-70.0	-10.9	-75.0	-24.3	- 8.3
14.4	-	-	-	-	-
18.0	-	-	-	-	-

FREQUENCY(MHZ)	TX ANTENNA-RX ANTENNA		
	DBM	H(DB ABOVE 1 μ A/M)	I(DB ABOVE 1 μ A)
2.0	-60.0	+ 2.0	+18.0
4.4	-69.0	-16.6	- 0.6
7.9	-	-	-
11.2	-	-	-
14.4	-	-	-
18.0	-	-	-

CURRENT CALCULATED ASSUMING 1-METER RADIUS FROM CONDUCTORS

FIGURE 75

SWEPT-FREQUENCY VHF/UHF MEASUREMENTS IN
 NORTH MINE WITH TX AT Y AND WITH RX AT
 064 ORE PASS 390 FEET AWAY 1 WATT TRANSMIT
 POWER INTO PRACTICAL WHIP ANTENNAS AMAX

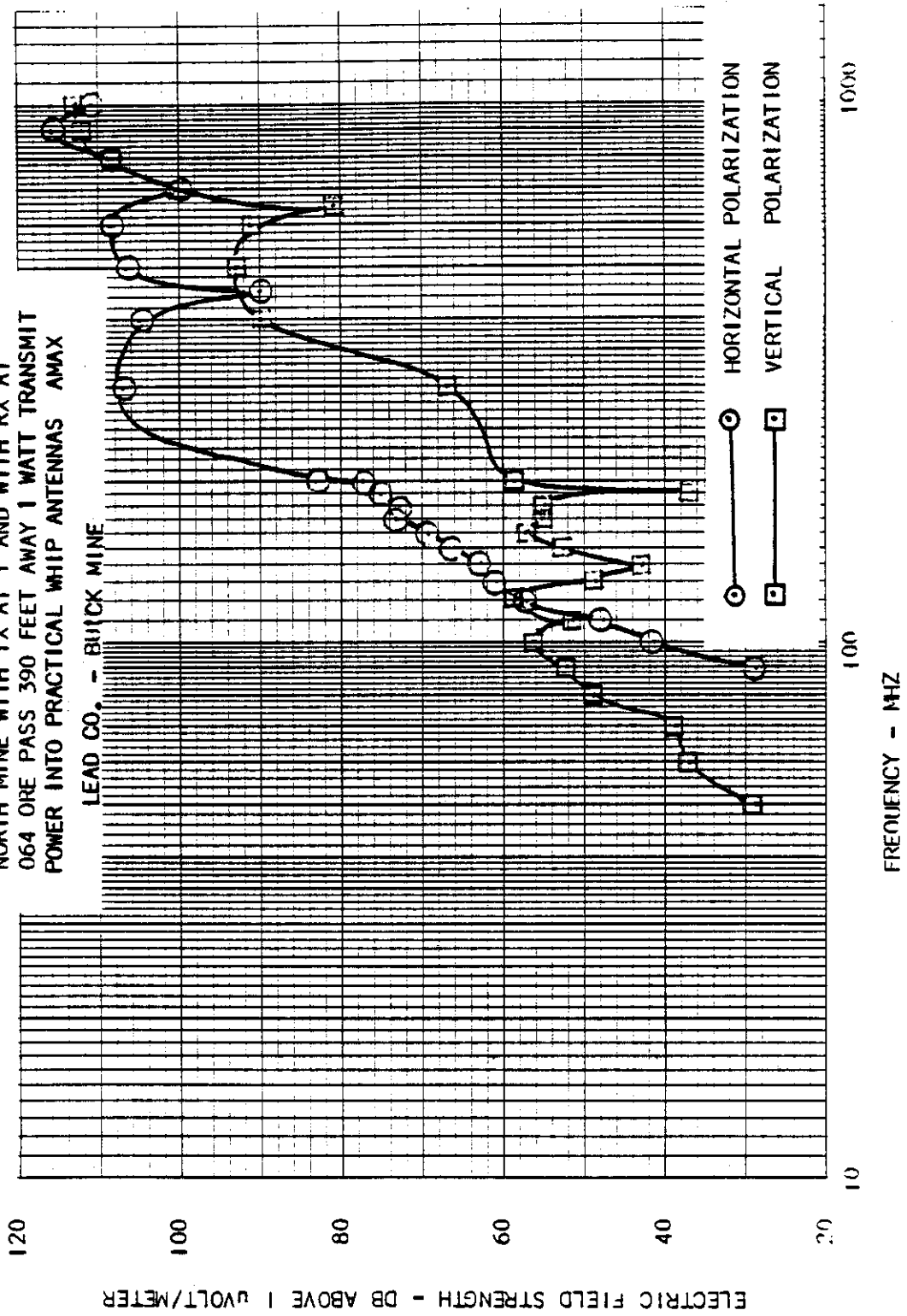

TABLE 32

REDUCED VHF ELECTRIC FIELD STRENGTH DATA TAKEN ON A SWEEP-FREQUENCY BASIS ALONG THE NORTH MINE TRACKED HAULAGE DRIFT AT 064 ORE PASS FROM A TRANSMITTER LOCATED AT THE NORTHWEST/NORTHEAST Y 1 WATT TRANSMIT POWER FOR PRACTICAL WHIP ANTENNAS

FREQ(MHZ)	AMAX LEAD CO.		- BUICK MINE	
	HORIZONTAL POLARIZATION DBM E(DB ABOVE 1 μ V/M)	VERTICAL POLARIZATION DBM E(DB ABOVE 1 μ V/M)	HORIZONTAL POLARIZATION DBM E(DB ABOVE 1 μ V/M)	VERTICAL POLARIZATION DBM E(DB ABOVE 1 μ V/M)
50	-	-	-80.0	+28.7
60	-	-	-66.0	+37.1
70	-	-	-64.0	+38.7
80	-	-	-53.5	+49.1
90	-76.0	+29.1	-53.0	+52.1
100	-70.0	+41.5	-55.0	+56.5
110	-63.0	+47.8	-59.0	+51.8
120	-57.0	+57.2	-56.0	+58.2
130	-53.0	+60.8	-65.5	+48.3
140	-48.0	+62.8	-68.0	+42.8
150	-46.0	+66.3	-60.0	+52.3
160	-42.0	+69.7	-54.0	+57.7
170	-38.0	+73.6	-56.0	+55.6
180	-42.0	+73.1	-60.0	+55.1
190	-41.0	+75.5	-80.0	+36.5
200	-39.0	+77.5	-58.0	+58.5

TABLE 33

REDUCED UHF ELECTRIC FIELD STRENGTH DATA TAKEN ON A SWEEP-FREQUENCY BASIS ALONG THE NORTH MINE TRACKED HAULAGE DRIFT AT 064 ORE PASS FROM A TRANSMITTER LOCATED AT THE NORTHWEST/NORTHEAST Y 1 WATT TRANSMIT POWER FOR PRACTICAL WHIP ANTENNAS
 AMAX LEAD CO. - BUICK MINE

FREQ(MHZ)	HORIZONTAL POLARIZATION		VERTICAL POLARIZATION	
	DBM	E(DB ABOVE 1 μ V/M)	DBM	E(DB ABOVE 1 μ V/M)
200	-25.0	+83.5	-	-
300	-10.0	+107.1	-50.0	+ 67.1
400	-17.5	+105.4	-33.0	+ 89.9
500	-17.0	+106.3	-30.0	+ 93.3
600	-20.0	+108.7	-37.0	+ 91.7
700	-30.0	+100.5	-30.0	+100.5
800	-24.5	+109.0	-24.0	+109.5
900	-19.0	+116.6	-23.5	+112.1
1000	-21.0	+111.8	-30.0	+102.8

FIGURE 76

PROCESSED MF AND HF DATA FROM AMAX LEAD 50. BUICK MINE ON 390-FOOT TEST RANGE FOR FLAT NIA OF -2 DB WITH AND WITHOUT ATTENUATION

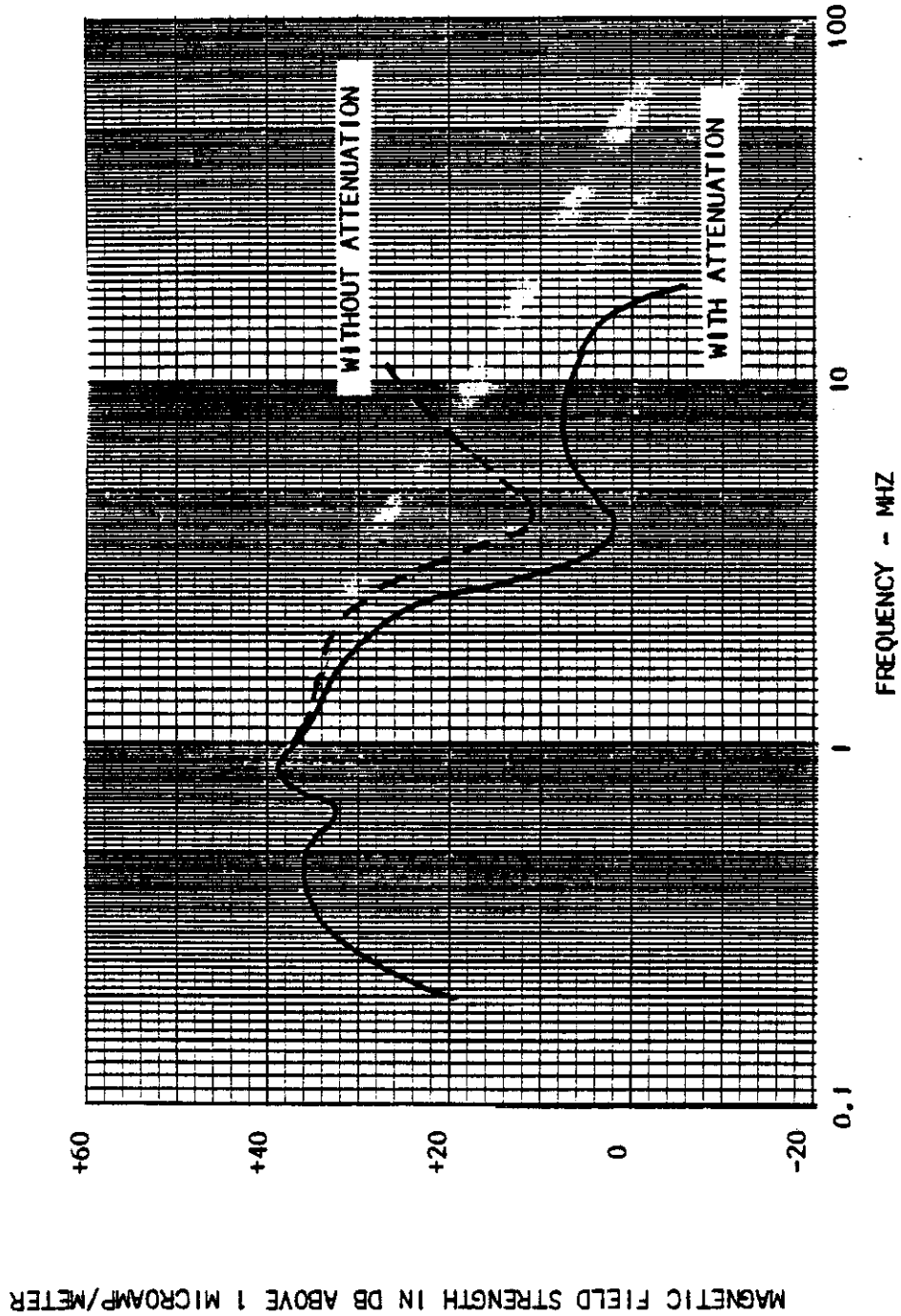

80

MONOFILAR MODE CURRENT IN DB ABOVE 1 MICROMPERE

FIGURE 77

MF/HF CHARACTERIZATION OF TRACK AS A MONOFILAR CONDUCTOR COMPARING COMPUTED CURRENTS AND CURRENTS DERIVED FROM MAGNETIC FIELD STRENGTH DATA MAGMA COPPER CO. SAN MANUEL MINE

MONOFILAR EXCITATION ONLY

DESTRUCTIVE INTERFERENCE DUE TO PHASE CANCELLATION

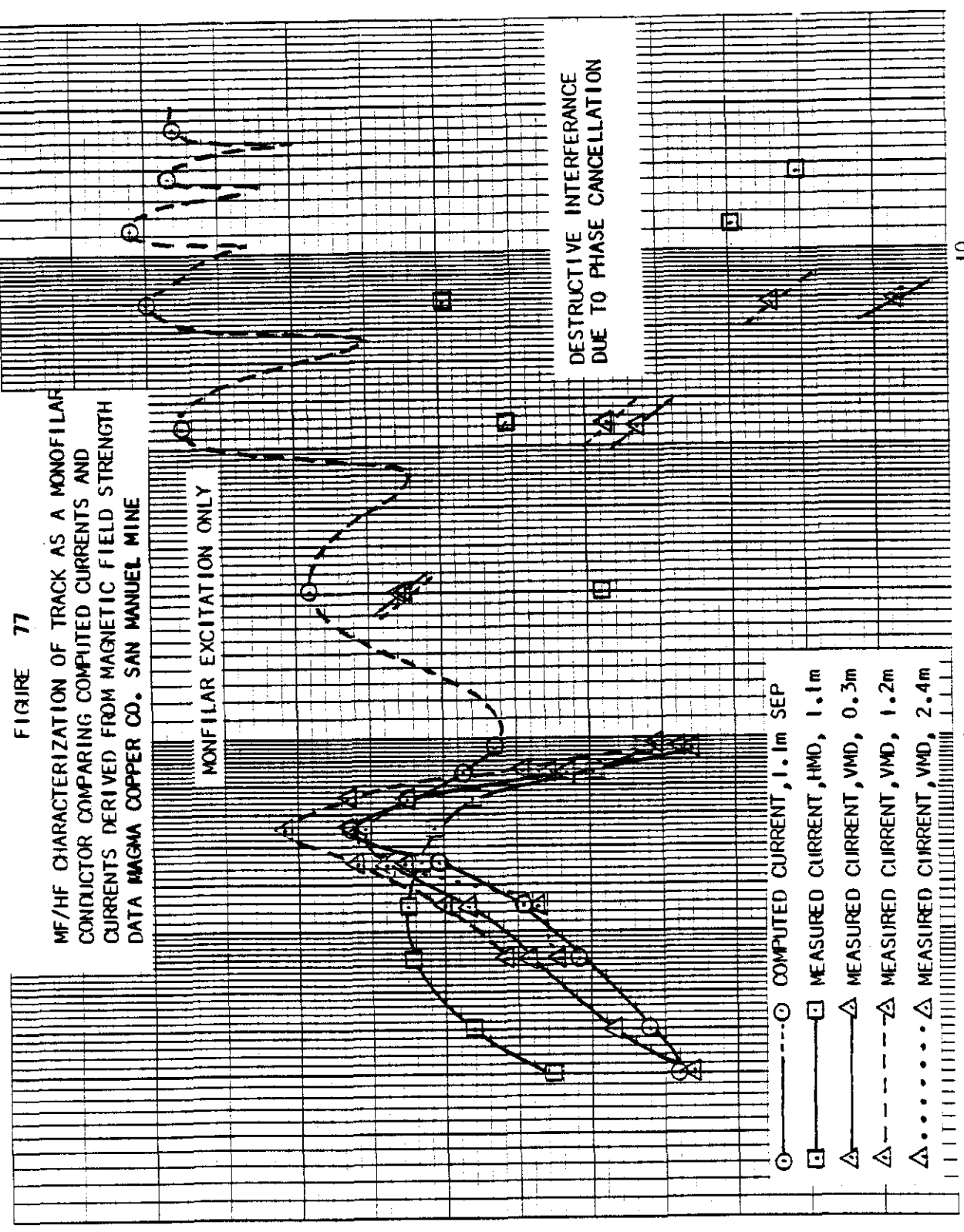

FREQUENCY - MHZ

10

TABLE 34

REDUCED MAGNETIC FIELD STRENGTH AND COUPLED CURRENT DATA
 TAKEN ON A SWEEP-FREQUENCY BASIS IN THE CAR-CLEANER TRACK
 DRIFT WHICH CONTAINED NO OTHER SIGNIFICANT CONDUCTORS AT MF
 1 WATT TRANSMIT POWER MAGMA COPPER CO. SAN MANUEL MINE

TX & RX ANTS COPLANAR HMD 1.1M ABOVE TRACK CENTER

FREQUENCY(MHZ)	DBM	H(DB ABOVE 1uA/M)	I(DB ABOVE 1uA)
0.20	-62.0	+ 7.5	+42.7
0.25	-56.5	+13.2	+48.4
0.35	-52.5	+16.9	+52.1
0.45	-51.0	+17.5	+52.7
0.55	-50.5	+16.5	+51.7
0.65	-49.5	+15.6	+50.8
0.75	-50.5	+12.8	+48.0
0.85	-56.0	+ 4.7	+39.9
0.95	-58.0	+ 1.0	+36.2

FREQ(MHZ)	RX ANT VMD SPACED AS GIVEN ABOVE RAIL TOP									ABOVE 1uA OR 1uA/M
	1-FT DBM	4-FT DBM	8-FT DBM	1-FT H(DB)	4-FT I(DB)	8-FT H(DB)	1-FT I(DB)	4-FT H(DB)	8-FT I(DB)	
0.20	-53.5	-	-	+16.0	+33.0	-	-	-	-	-
0.25	-48.0	-	-	+21.7	+38.7	-	-	-	-	-
0.35	-42.0	-56.0	-71.0	+27.7	+44.4	+13.4	+45.9	- 1.6	+42.2	-
0.45	-37.0	-51.0	-68.0	+31.5	+48.5	+17.5	+50.0	- 0.1	+43.7	-
0.55	-30.0	-43.5	-58.0	+37.0	+54.0	+23.5	+56.0	+ 9.0	+52.8	-
0.65	-27.0	-37.0	-52.5	+38.1	+55.1	+28.5	+61.0	+12.6	+56.4	-
0.75	-28.0	-39.5	-55.0	+35.3	+52.3	+24.2	+56.7	+ 8.3	+52.1	-
0.85	-36.0	-49.0	-62.0	+24.7	+41.7	+12.1	+44.6	- 1.3	+42.5	-
0.95	-43.0	-56.0	-69.0	+16.0	+33.0	+ 3.2	+37.5	-10.0	+33.8	-

TABLE 35

REDUCED MAGNETIC FIELD STRENGTH AND COUPLED CURRENT DATA
 TAKEN ON A SWEEP-FREQUENCY BASIS IN THE CAR-CLEANER TRACK
 DRIFT WHICH CONTAINED NO OTHER SIGNIFICANT CONDUCTORS AT HF
 1 WATT TRANSMIT POWER MAGMA COPPER CO. SAN MANUEL MINE
 TX & RX ANTS COPLANAR HMD 1.1M ABOVE TRACK CENTER

FREQUENCY(MHZ)	DBM	H(DB ABOVE 1uA/M)		I (DB ABOVE 1uA)	
2.0	-58.0	+ 4.0		+39.2	
4.4	-42.0	+10.4		+45.6	
7.9	-37.0	+14.6		+49.8	
11.2	-56.0	- 5.3		+29.9	
14.4	-60.0	-10.0		+25.2	
18.0	-	-		-	

FREQ(MHZ)	RX ANT			VMD SPACED AS GIVEN ABOVE RAIL TOPS					
	1-FT DBM	4-FT DBM	8-FT DBM	1-FT H(DB)	1-FT I (DB)	4-FT H(DB)	4-FT I (DB)	8-FT H(DB)	8-FT I (DB)
2.0	-26.0	-42.0	-62.0	+36.0	+53.0	+20.0	+52.5	0.0	+43.8
4.4	-33.0	-46.5	-62.0	+19.4	+36.4	+ 5.9	+38.4	-9.6	+34.2
7.9	-50.0	-57.0	-	+ 1.6	+18.6	- 8.1	+27.1	-	-
11.2	-	-	-	-	-	-	-	-	-

H in DB ABOVE 1uA/M

I in DB ABOVE 1uA

and details of the track geometry is given in Figure 78.

Swept-frequency data is shown in Figure 79 for VHF and in Figure 80 for UHF.

Reduced MF CW data in the North and South mine legs of 2375-level in the carrier phone band at 145 KHz over an approximate 6000-foot test range is given in Figure 81 and in Table 36. The data was taken in a mobile train with the transmitter directly driving a dedicated wire network in the locomotive shop. Similar CW data taken at 520 KHz, but with the receiver in the fixed location, is shown in Figure 82 and in Table 37.

Processed MF swept-frequency data for flat -2 dB NIA taken over the 243-foot test range with attenuation for both VMD and HMD antenna orientations are given in Figure 83.

4.6 REDUCED DATA FROM HECLA CON-SIL MINE

MF and HF swept-frequency data taken on a 429-foot path for several antenna orientations is given in Figure 84 and in Tables 38 and 39 respectively for HMD and VMD orientations at MF and in Tables 40 and 41 respectively for HMD and VMD orientations at HF. Processed MF and HF data normalized for unity NIA is given in Figure 85.

VHF and UHF swept-frequency data taken over a 195-foot path is given in Figures 86 and 87 respectively for horizontal and vertical antenna polarizations and in Tables 42 and 43.

Reduced MF CW data at several frequencies over an approximate 1500-foot range are given in Figures 88 and 89 respectively for Sunshine raise and Winze shaft directions and is listed in Table 44.

Processed MF swept-frequency data for flat -2 dB NIA taken over a 429-foot range with and without attenuation is given in Figure 90.

FIGURE 78

COMPUTED MF/HF MONOFILAR MODE TRACK COUPLING CORRESPONDING TO CAR-CLEANER DRIFT MEASUREMENTS - MAGMA COPPER CO., SAN MANUEL MINE

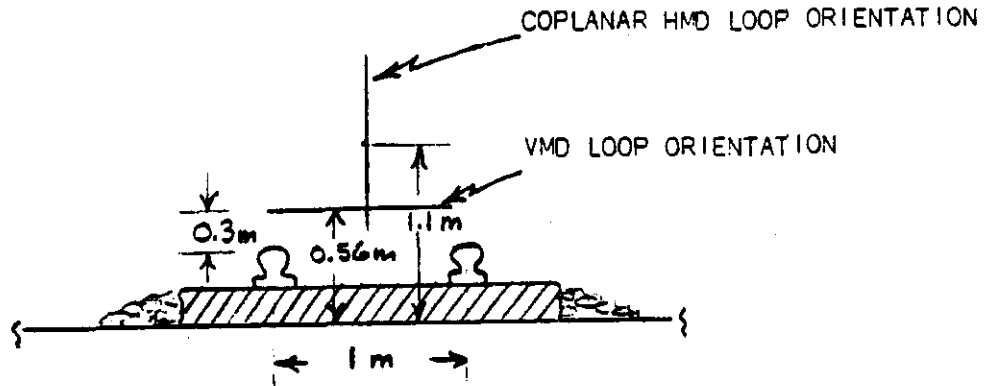

FREQ(MHZ)	TEST SET INA AMP \times M ² \times TURNS	TRACK CURRENT(2 COND.) DB ABOVE 1 μ AMPERE
0.20	0.183	34.0
0.25	0.206	37.0
0.35	0.231	40.9
0.45	0.274	44.6
0.55	0.435	50.3
0.65	0.730	56.3
0.75	0.410	52.5
0.85	0.231	48.6
0.95	0.164	46.6
2.0	0.326	59.0
4.4	0.410	67.9
7.9	0.291	70.0
11.2	0.231	71.0
14.4	0.130	68.2
18.0	0.103	68.1

NOTES: SURGE IMPEDANCE OF 100 OHMS / RAIL ASSUMED TO GROUND
 IMAGE RETURN PATH IS IN GROUND(ROCK)
 TRACK CURRENT IS TOTAL OF TWO LOOP VALUES
 EQUIVALENT H FIELD IS 29.2 DB BELOW CURRENT FOR
 SHOWN EXCITATION LOCATIONS (WHICH ARE ROUGHLY
 EQUIVALENT FOR BOTH ORIENTATIONS)

FIGURE 79

SWEPT-FREQUENCY VHF REDUCED DATA FOR PRACTICAL WHIP ANTENNAS TAKEN IN CAR-CLEANER TRACKED DRIFT AT A RANGE OF 111 FEET FROM THE TRANSMITTER - 1 WATT TRANSMIT POWER
MAGMA COPPER CO. SAN MANUEL MINE

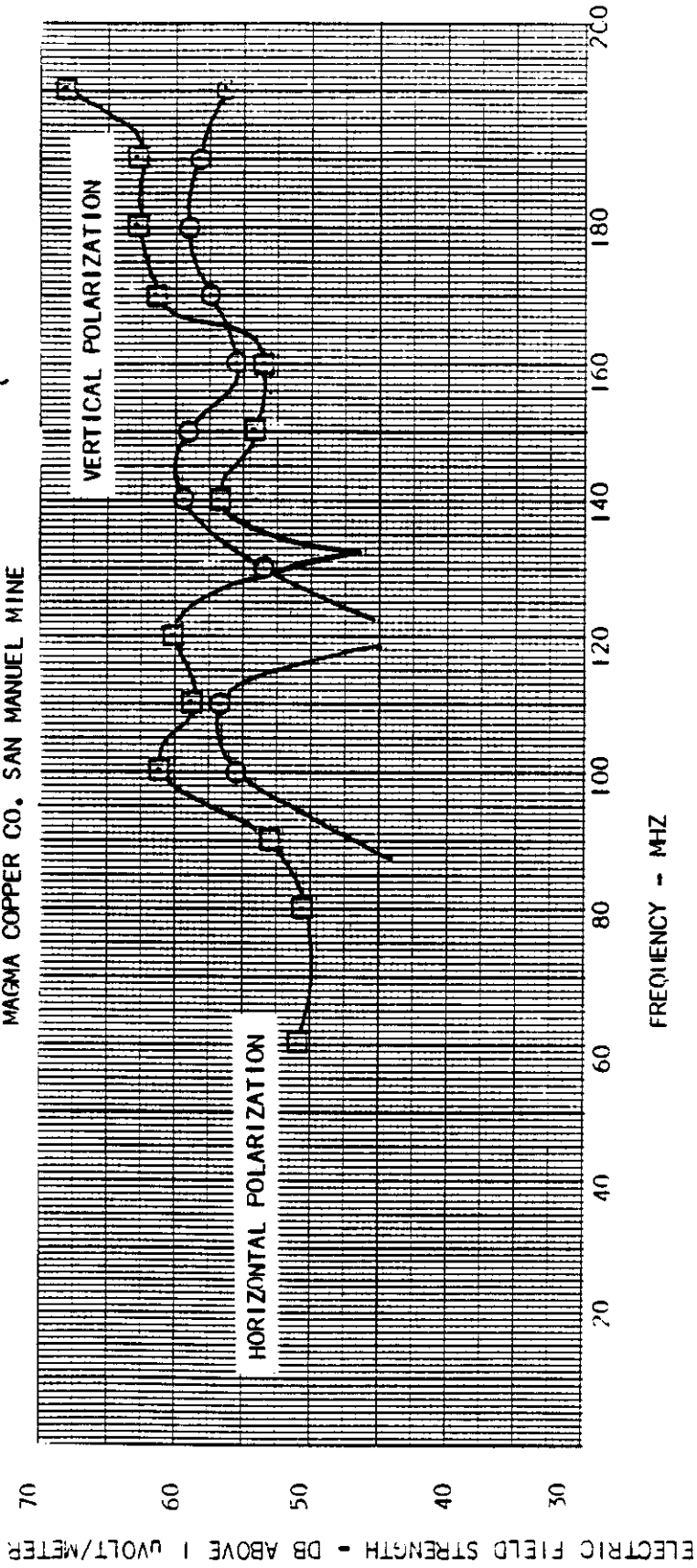

FIGURE 80

SWEPT-FREQUENCY UHF REDUCED DATA TAKEN IN THE
CAR-CLEANER TRACKED DRIFT AT A RANGE OF 243
FEET FROM THE TRANSMITTER FOR PRACTICAL WHIP
ANTENNAS MAGMA COPPER CO., SAN MANUEL MINE
1 WATT TRANSMIT POWER

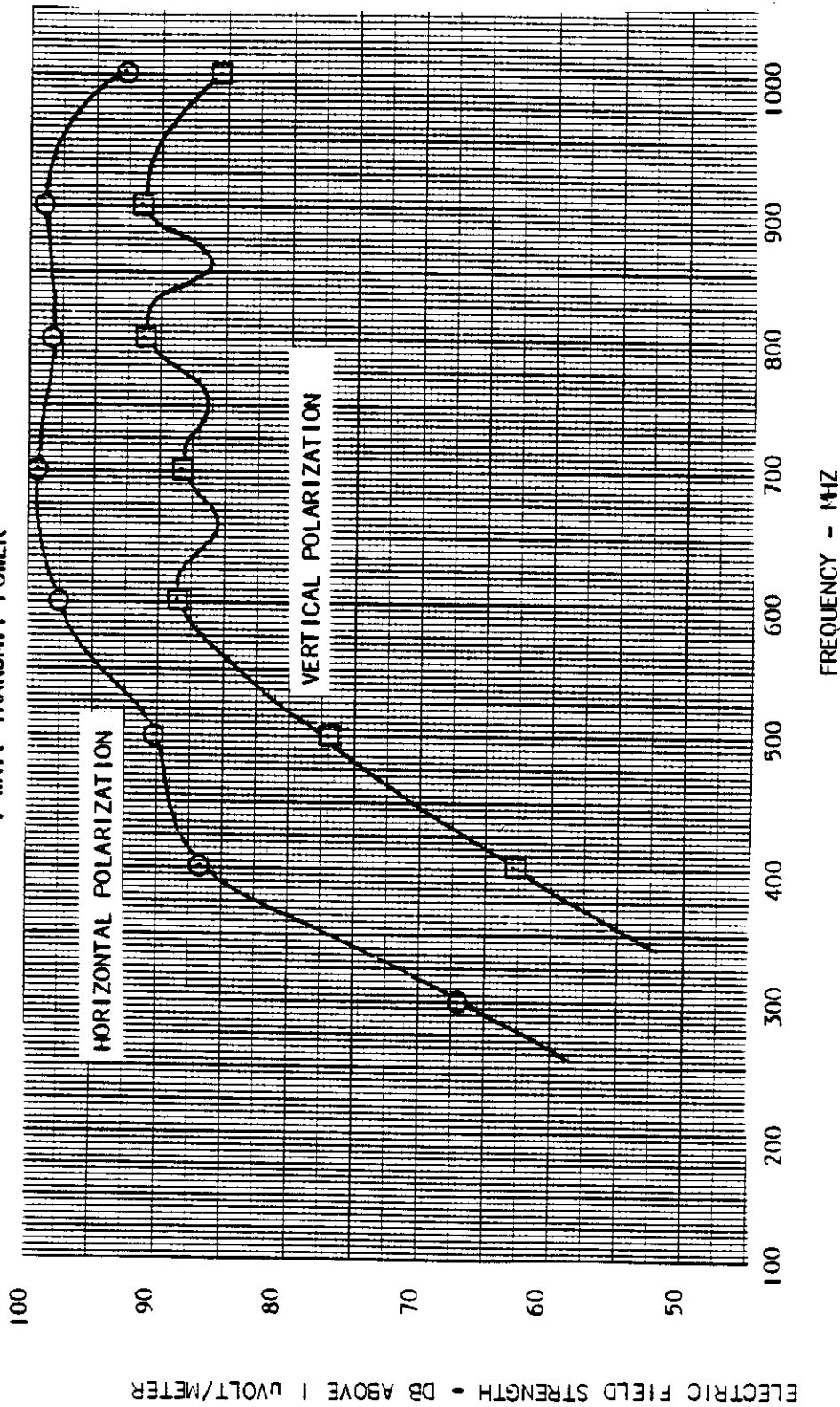

FIGURE 81

TEST SYSTEM REDUCED MF DATA EXPRESSED AS
 MONOFILAR MODE CURRENT FROM CARRIER PHONE
 TESTING ON BASE-VEHICLE AND VEHICLE-BASE
 PATHS AT 145KHZ AND 520KHZ RESPECTIVELY
 MAGMA COPPER CO., SAN MANUEL MINE
 (SEE MAGMA COPPER MINE MAP IN FIGURE 30)

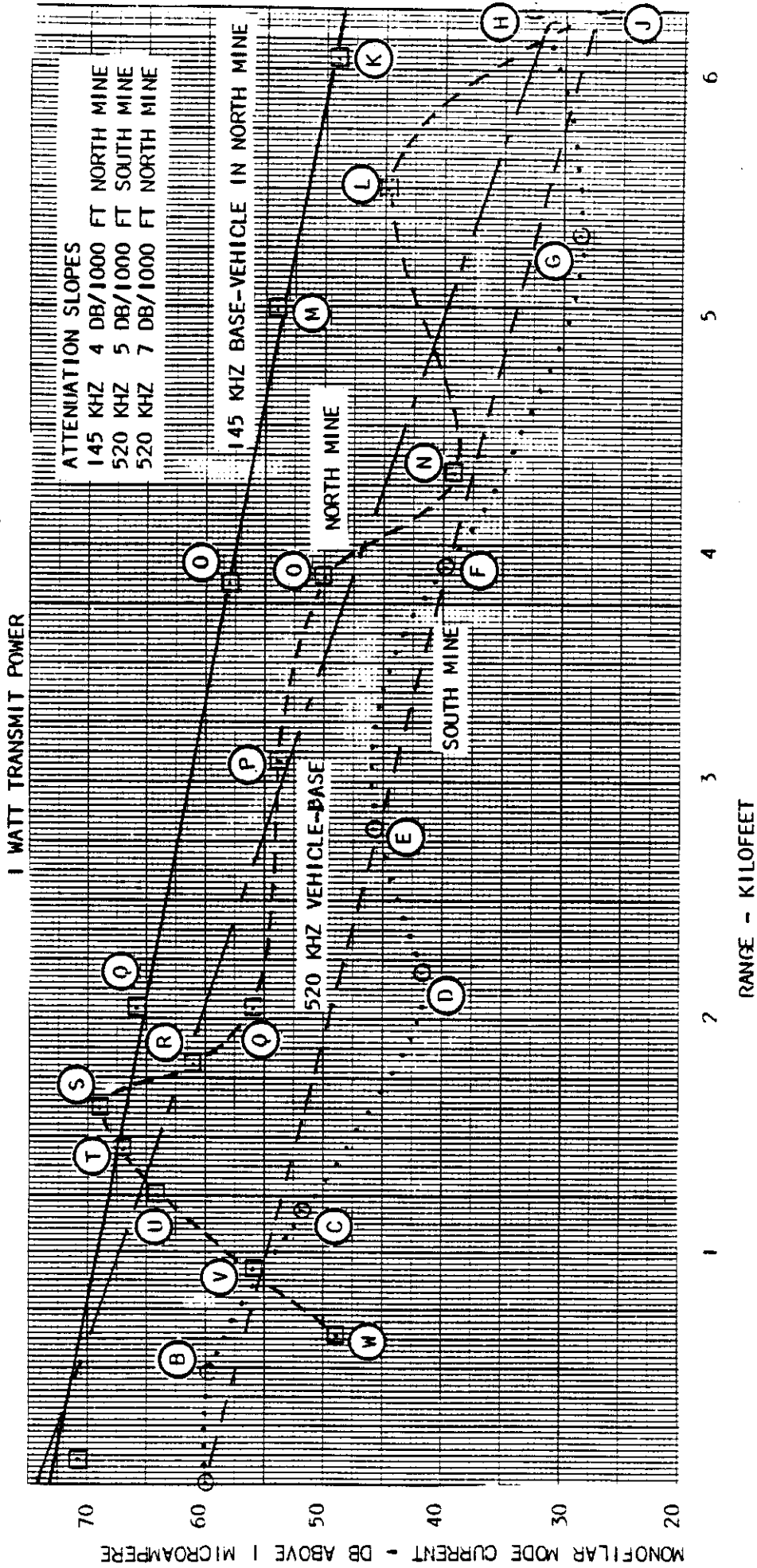

TABLE 36

REDUCED DATA FROM 145 KHZ CARRIER PHONE TESTS ON THE
 BASE-VEHICLE LINKAGE ALONG THE MEASUREMENT TRAVERSE
 MAGMA COPPER CO. SAN MANUEL MINE 1 WATT TX POWER

LOCATION	DBM	MONOFILAR CURRENT DB ABOVE 1 μ AMPERE
G	- 5.0	+69.0
K	-25.0	+49.0
M	-20.0	+54.0
O	-16.0	+58.0
Q	- 8.0	+66.0

FIGURE 82

REDUCED DATA EXPRESSED AS MONOFILAR MODE
 CURRENT LEVELS ON VEHICLE-BASE PATH AT 520KHZ
 DIFFERENTIATING BETWEEN CURRENT RECEIVED IN
 RADIO SHOP AND THAT EXPECTED ON THE TROLLEY
 CONDUCTOR SYSTEM - MAGMA COPPER CO. SAN MANUEL
 MINE (SEE SAN MANUEL MINE MAP IN FIGURE 30)

MONOFILAR MODE CURRENT LEVEL RECEIVED IN RADIO SHOP - DB ABOVE 1UAMP/METER

ESTIMATED MONOFILAR MODE CURRENT LEVEL ON TROLLEY - DB ABOVE 1UAMP/METER

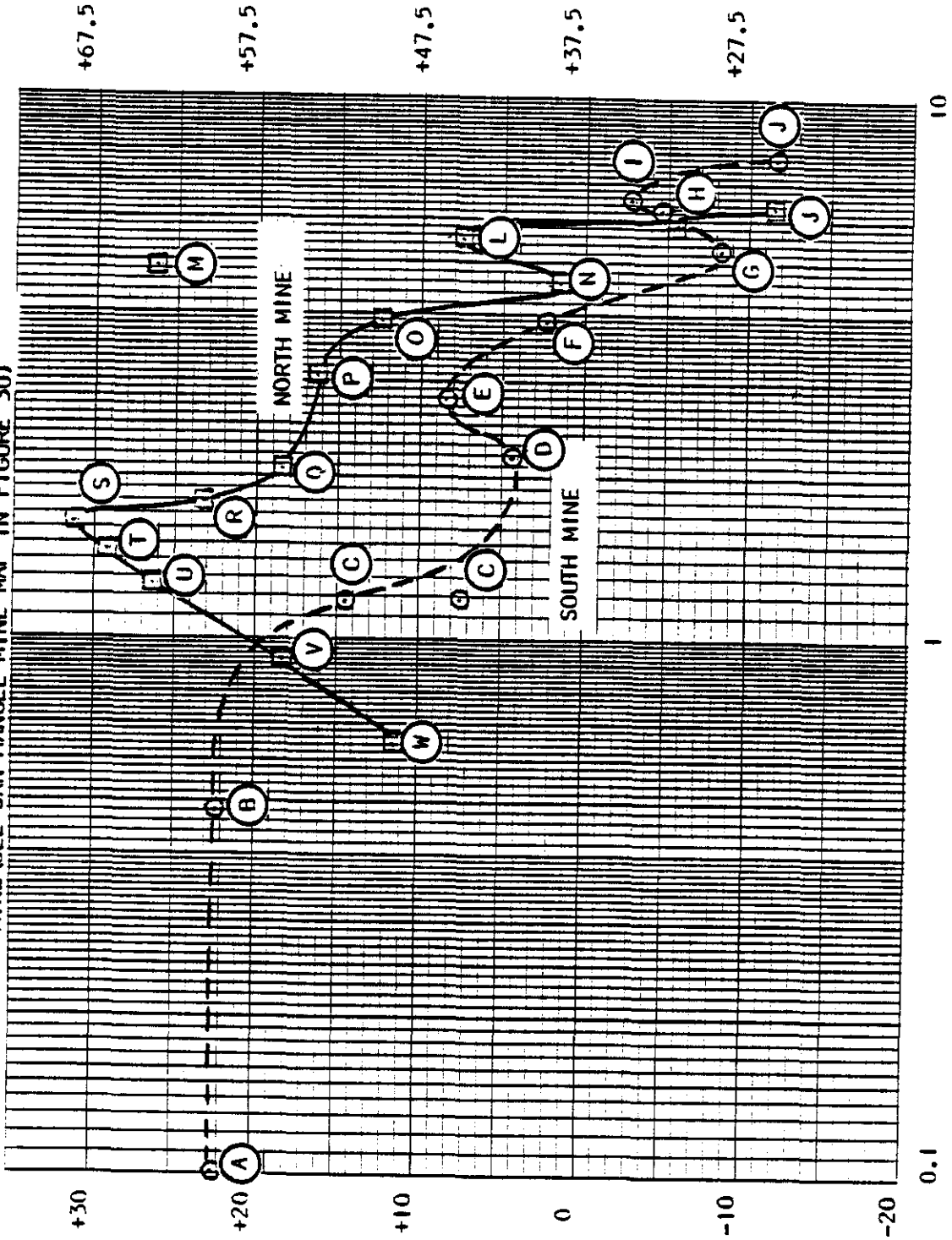

TABLE 37

REDUCED DATA FROM 520 KHZ CARRIER PHONE TESTS ON THE
VEHICLE-BASE LINKAGE ALONG THE MEASUREMENT TRAVERSE
MAGMA COPPER CO. - SAN MANUEL MINE

LOCATION	DBM	MONOFILAR CURRENT DB ABOVE 1 μ AMPERE	CORRECTED FOR PREAMP		
A	-39.0	+22.4			
B	-39.0	+22.4	"	"	"
C	-47.0	+14.4	"	"	"
C	-54.0	+ 7.4	"	"	"
D	-57.0	+ 4.4	"	"	"
E	-53.0	+ 8.4	"	"	"
F	-59.0	+ 2.4	"	"	"
G	-69.0	- 8.1	"	"	"
H	-66.0	- 4.6	"	"	"
I	-64.0	- 2.6			
J	-73.0	-11.6			
K	-67.0	- 5.6			
L	-54.0	+ 7.4			
M	-35.0	+26.4			
N	-60.0	+ 1.4			
O	-49.0	+12.4			
P	-45.0	+16.4			
Q	-43.0	+18.4			
R	-38.0 PORT -45.0 VEHIC	+23.4			
S	-30.0 PORT -28.0 VEHIC	+31.4			
T	-32.0	+29.4			
U	-35.0	+26.4			
V	-30.0 PORT -43.0 VEHIC	+18.4			
W	-50.0	+11.4			

NOTE: THESE CURRENT VALUES AS RECEIVED IN THE RADIO SHOP ARE
INCREASED BY 37.5 DB TO GIVE ACTUAL MONOFILAR CURRENT
ON THE TROLLEY SYSTEM

FIGURE 83

PROCESSED MF AND HF DATA FROM MAGMA SAN MANUEL MINE ON 243-FOOT
TEST RANGE FOR FLAT NIA OF -2 DB FOR HMD AND VMD ANTENNA ORIENTATIONS
1 WATT TRANSMIT POWER AND TEST SYSTEM ANTENNAS

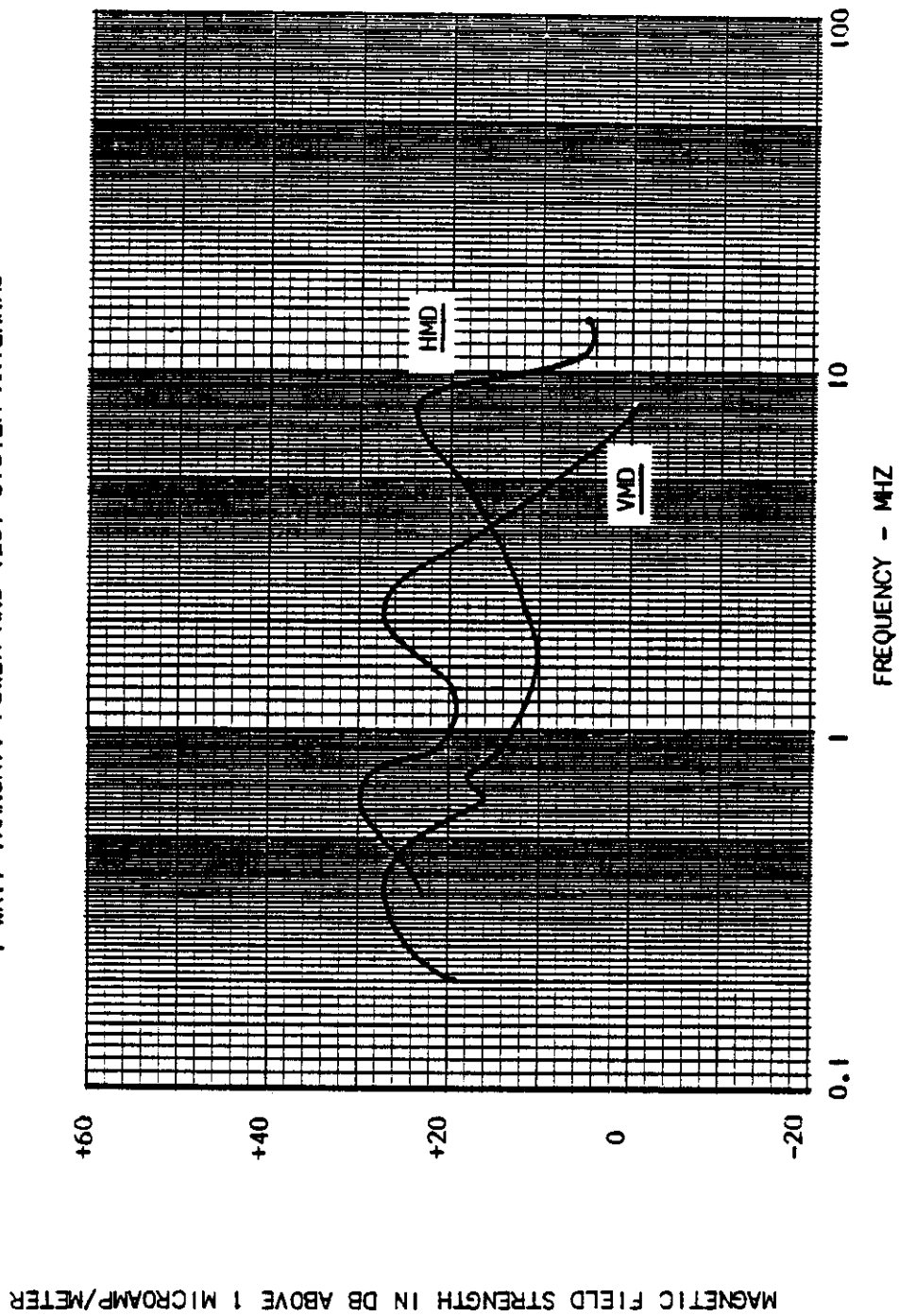

FIGURE 84

REDUCED MAGNETIC FIELD STRENGTH DATA AT
 MF/HF TAKEN ON 429 FOOT PATH IN 3000-LEVEL
 NORTH CROSSCUT - HECLA CON-SIL MINE

NOTE: BOTH TX & RX ANTENNAS IN DESIGNATED
 DRIFT POSITION INDICATED IN THE LEGEND

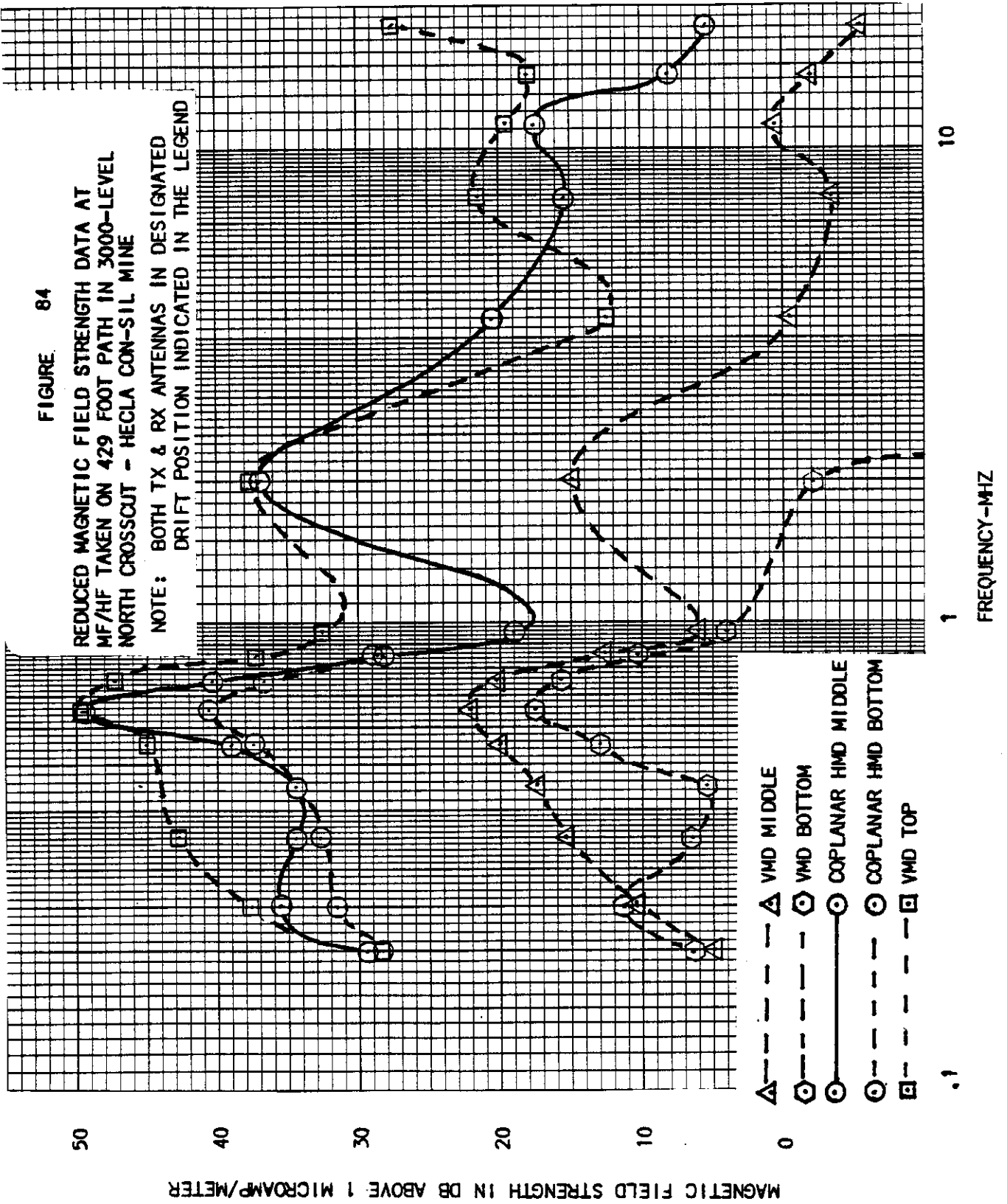

TABLE 38

REDUCED MAGNETIC FIELD STRENGTH AND COUPLED CURRENT DATA
 TAKEN ON A SWEEP-FREQUENCY BASIS IN THE 3000- LEVEL NORTH
 CROSSCUT ON A 429 FOOT PATH AT M FOR VMD ANTENNA ORIENTATIONS
 1 WATT TRANSMIT POWER FOR TEST SYSTEM ANTENNAS
 HECLA CON-SIL MINE

FREQ(MHZ)	TOP	MID	BOT	TOP		MID		BOT	
	DBM	DBM	DBM	H(DB)	I(DB)	H(DB)	I(DB)	H(DB)	I(DB)
0.20	-41.0	-62.0	-61.0	+28.5	+42.2	+7.5	+40.0	+8.5	+48.5
0.25	-32.0	-59.0	-58.5	+37.7	+51.4	+10.7	+43.2	+11.2	+51.2
0.35	-26.5	-54.0	-63.0	+42.9	+56.6	+15.4	+47.9	+6.4	+46.4
0.45	-23.0	-51.0	-63.0	+45.5	+59.2	+17.5	+50.0	+5.5	+45.5
0.55	-22.0	-47.0	-54.0	+45.0	+58.7	+20.0	+52.5	+13.0	+53.0
0.65	-16.0	-43.0	-47.5	+49.1	+62.8	+22.1	+54.6	+17.6	+57.6
0.75	-16.0	-43.0	-47.5	+47.3	+61.0	+20.3	+52.8	+15.8	+55.8
0.85	-23.5	-48.0	-50.5	+37.2	+50.9	+12.7	+45.2	+10.2	+50.2
0.95	-26.5	-53.0	-55.0	+32.5	+46.2	+6.0	+38.5	+4.0	+44.2

H in DB ABOVE 1uA/M

I in DB ABOVE 1uA

TABLE 39

REDUCED MAGNETIC FIELD STRENGTH AND COUPLED CURRENT DATA
 TAKEN ON A SWEEP-FREQUENCY BASIS IN THE 3000-LEVEL NORTH
 CROSSCUT ON A 429 FOOT PATH AT HF FOR HMD ANTENNA ORIENTATIONS
 1 WATT TRANSMIT POWER
 HECLA CON-SIL MINE

FREQ (MHZ)	CURRENT PROBE		TX & RX ANTS COLLINEAR HMD					
	DBM	I (DB)	DBM	MIDDLE		BOTTOM		I (DB)
				H (DB)	I (DB)	DBM	H (DB)	
0.20	+2.0	+66.5	-40.0	+29.5	+56.1	-41.0	+28.5	+67.5
0.25	+4.0	+68.0	-34.0	+35.7	+62.3	-38.0	+31.7	+70.7
0.35	+4.0	+66.4	-35.0	+34.4	+61.0	-36.5	+32.9	+71.9
0.45	+4.0	+65.8	-34.0	+34.5	+61.1	-34.0	+34.5	+73.5
0.55	+4.0	+65.3	-28.0	+39.0	+65.6	-29.5	+37.5	+76.5
0.65	+4.0	+65.0	-15.5	+49.6	+76.2	-24.5	+40.6	+79.6
0.75	+4.0	+64.8	-23.0	+40.3	+66.9	-26.5	+36.8	+75.8
0.85	+4.0	+64.8	-32.5	+28.2	+54.8	-32.0	+28.7	+67.5
0.95	-	-	-40.0	+19.0	+45.6	-	-	-

TABLE 40

REDUCED MAGNETIC FIELD STRENGTH AND COUPLED CURRENT DATA
 TAKEN ON A SWEEP-FREQUENCY BASIS IN THE 3000-LEVEL NORTH
 CROSSCUT ON A 429 FOOT PATH AT HF FOR VMD ANTENNA ORIENTATIONS
 1 WATT TRANSMIT POWER
 HECLA CON-SIL MINE

FREQ(MHZ)	DBM			TOP		MID		BOT	
	TOP	MID	BOT	H(DB)	I(DB)	H(DB)	I(DB)	H(DB)	I(DB)
2.0	-24.5	-47.0	-64.0	+37.5	+51.2	+15.0	+47.5	-2.0	+38.0
4.4	-40.0	-53.0	-74.0	+12.4	+26.1	+0.6	+31.9	-21.6	+18.4
7.9	-30.0	-55.0	-66.0	+21.6	+35.3	-3.4	+29.1	-14.4	+25.6
11.2	-31.0	-50.0	-63.0	+19.7	+33.4	+0.7	+33.2	-12.3	+27.7
14.4	-32.0	-52.0	-77.0	+18.0	+31.7	-2.0	+30.5	-27.0	+13.0
18.0	-22.0	-55.0	-	+27.7	+41.4	-5.3	+27.2	-	-

H in DB ABOVE 1 μ A/M

I in DB ABOVE 1 μ A

TABLE 41

REDUCED MAGNETIC FIELD STRENGTH AND COUPLED CURRENT DATA
 TAKEN ON A SWEEP-FREQUENCY BASIS IN THE 3000-LEVEL NORTH
 CROSSCUT ON A 429 FOOT PATH AT HF FOR HMD ANTENNA ORIENTATIONS
 1 WATT TRANSMIT POWER
 HECLA CON-SIL MINE

FREQ(MHZ)	CURRENT PROBE		TX & RX ANTS HMD COLLINEAR			TX & RX ANTS HMD BROADSIDE (AXIAL)		
	DBM	I (DB)	DBM	H(DB)	I (DB)	DBM	H(DB)	I (DB)
2.0	+4.0	+64.0	-25.0	+37.0	+63.6	-40.0	+22.0	+48.6
4.4	+2.5	+62.0	-32.0	+20.4	+47.0	-50.0	+2.4	+29.0
7.9	-4.0	+55.2	-36.0	+15.6	+42.2	-47.0	+4.6	+31.2
11.2	-4.0	+55.1	-33.0	+17.7	+44.3	-31.0	+19.7	+46.3
14.4	-20.0	+39.0	-42.0	+8.0	+34.6	-32.0	+18.0	+44.6
18.0	-14.5	+44.5	-44.0	+5.7	+32.3	-40.0	+9.7	+36.3

H in DB ABOVE 1 μ A/M

I in DB ABOVE 1 μ A

FIGURE 85

REDUCED DATA EXPRESSED AS MONOFILAR LINE
 CURRENT NORMALIZED TO NIA-UNITY TAKEN ON
 429 FOOT PATH IN 3000-LEVEL NORTH CROSSCUT

NOTE: BOTH TX & RX ANTENNAS IN DESIGNATED
 POSITION

HECLA CON-SIL MINE

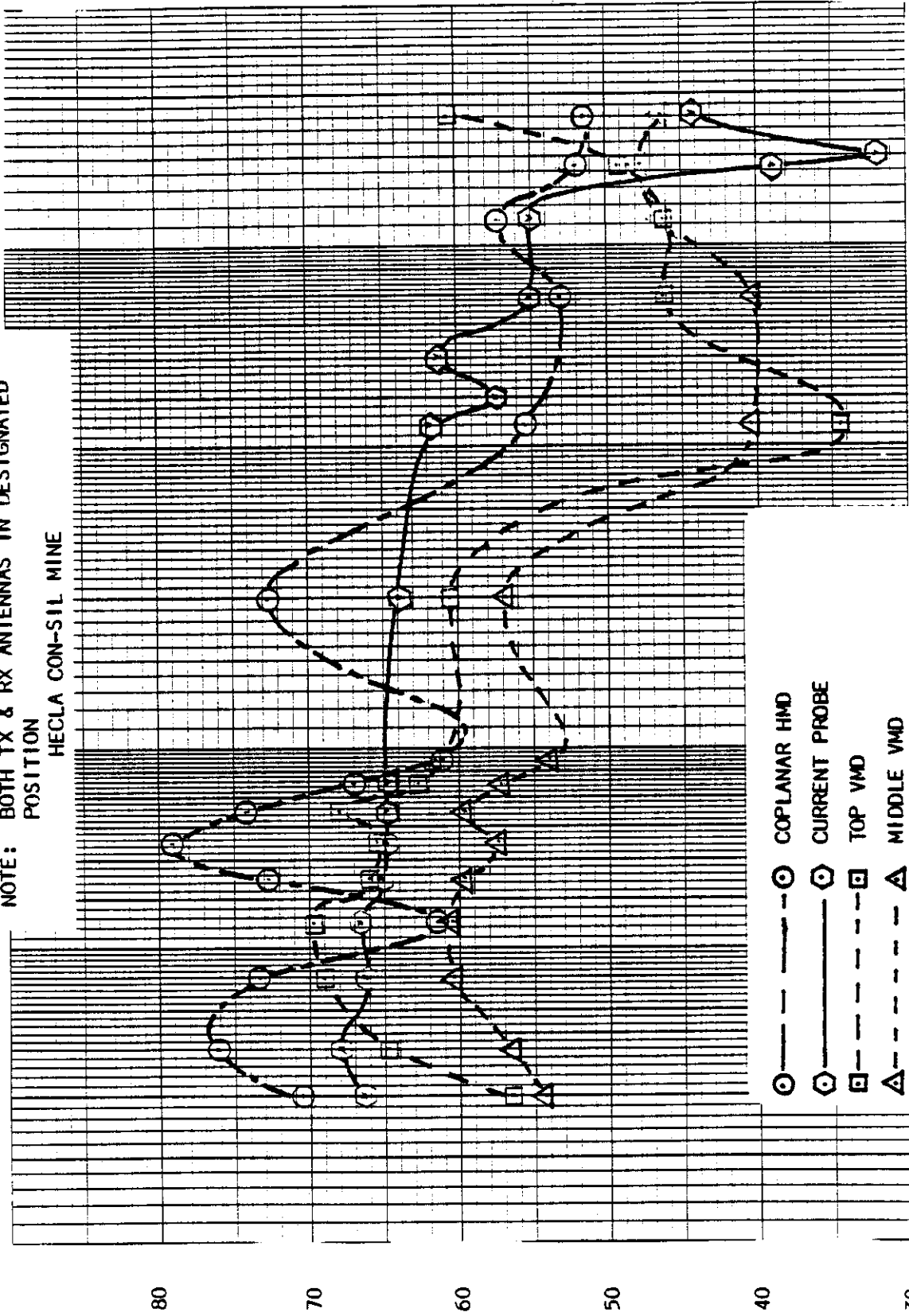

MONOFILAR MODE CURRENT DB ABOVE 1 MICRAMP.

.1

1

10

FREQUENCY - M/IZ

FIGURE 86

REDUCED ELECTRIC FIELD STRENGTH DATA FOR
VHF/UHF HORIZONTAL POLARIZATION TAKEN IN
3000-LEVEL NORTH CROSSCUT ON A 195 FOOT PATH
(LOCATION 2) - 1 WATT TX - PRACTICAL WHIP
ANTENNAS - HECLA CON-SIL MINE

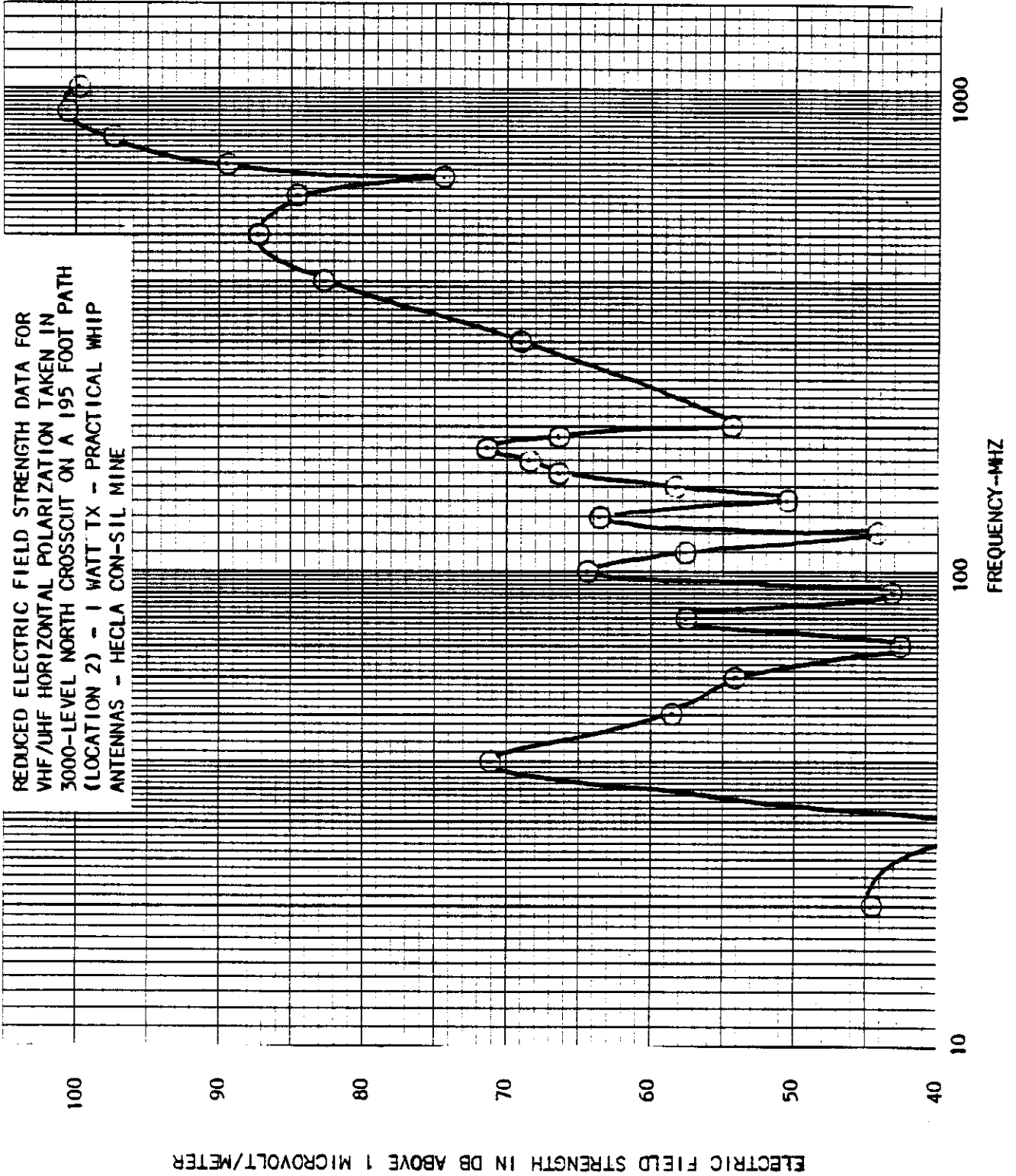

FIGURE 87

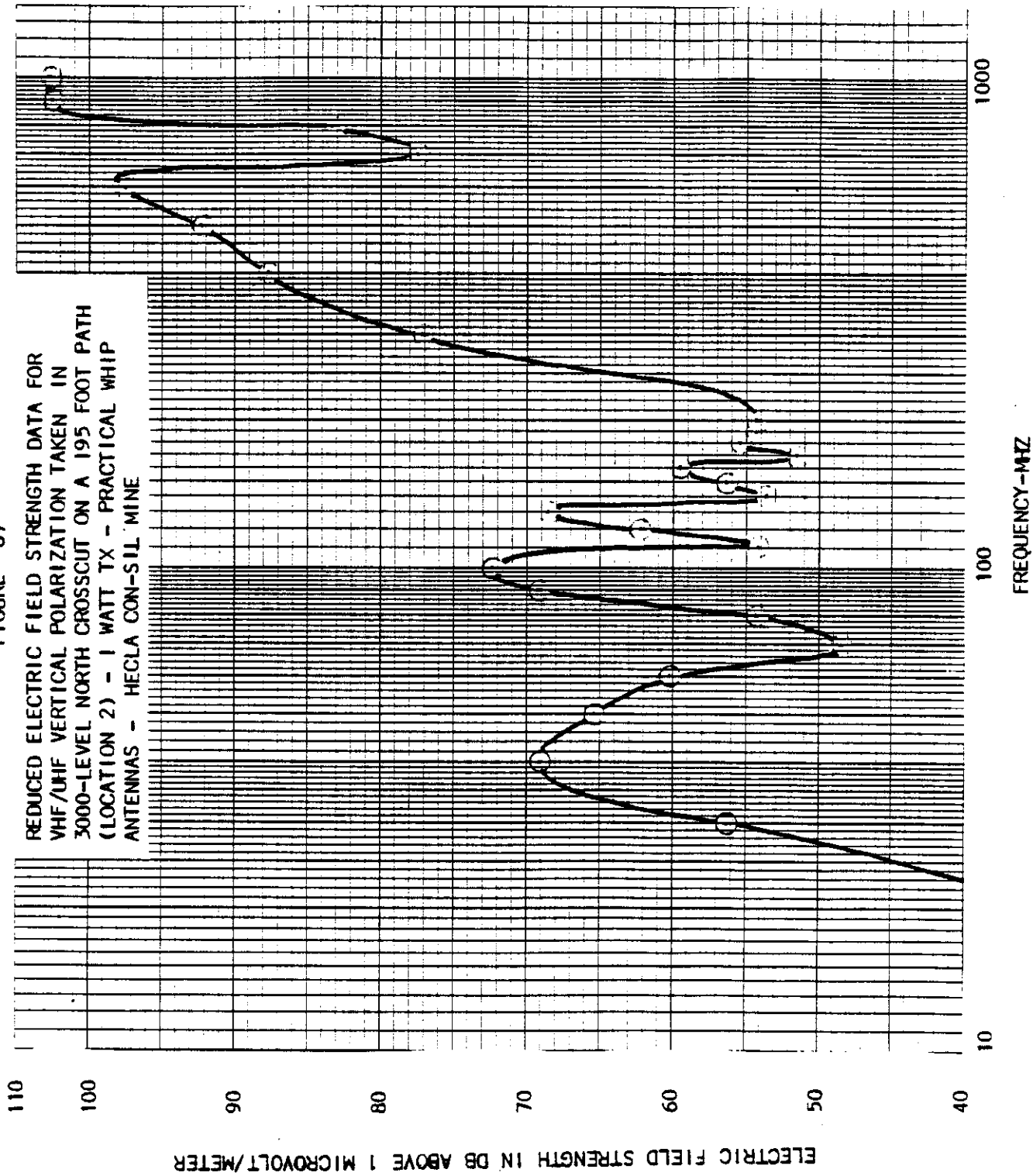

TABLE 42

REDUCED VHF ELECTRIC FIELD STRENGTH DATA TAKEN ON A
 SWEEP-FREQUENCY BASIS ON A 195 FOOT PATH IN 3000-LEVEL
 NORTH CROSSCUT 1 WATT TRANSMIT POWER - PRACTICAL WHIP
 ANTENNAS - HECLA CON-SIL MINE

FRÉQ(MHZ)	HORIZONTAL POLARIZATION		VERTICAL POLARIZATION	
	DBM	E(DB ABOVE 1 μ V/M)	DBM	E(DB ABOVE 1 μ V/M)
20	-60.0	+44.7	-72.0	+32.7
30	-68.0	+35.1	-47.0	+56.1
40	-36.0	+71.2	-38.0	+69.2
50	-50.0	+58.7	-43.0	+65.7
60	-49.0	+54.1	-42.0	+60.1
70	-60.0	+42.7	-54.0	+48.7
80	-45.0	+57.6	-48.0	+54.6
90	-62.0	+43.1	-36.0	+69.1
100	-47.0	+64.5	-39.0	+72.5
110	-53.0	+57.8	-56.5	+54.3
120	-70.0	+44.2	-52.0	+62.2
130	-50.0	+63.8	-45.0	+68.8
140	-60.0	+50.8	-57.0	+53.8
150	-54.0	+58.3	-56.0	+56.3
160	-45.0	+66.7	-52.0	+59.7
170	-43.0	+68.6	-60.0	+51.6
180	-44.0	+71.1	-60.0	+55.1
190	-50.0	+66.5	-62.0	+54.5
200	-60.0	+56.5	-61.0	+55.5

TABLE 43

REDUCED UHF ELECTRIC FIELD STRENGTH DATA TAKEN ON A
 SWEPT-FREQUENCY BASIS ON A 195 FOOT PATH IN 3000-LEVEL
 NORTH CROSSCUT 1 WATT TRANSMIT POWER - PRACTICAL WHIP
 ANTENNAS-- HECLA CON-SIL MINE

FREQ(MHZ)	HORIZONTAL POLARIZATION		VERTICAL POLARIZATION	
	DBM	E(DB ABOVE 1 μ V/M)	DBM	E(DB ABOVE 1 μ V/M)
200	-54.0	+54.5	-54.0	+54.5
300	-48.0	+69.1	-40.0	+77.1
400	-40.0	+82.9	-35.0	+87.9
500	-36.0	+87.3	-31.0	+92.3
600	-44.0	+84.7	-31.0	+97.7
700	-41.0	+89.5	-53.0	+77.5
800	-36.0	+97.5	-50.0	+83.5
900	-35.0	+100.6	-33.0	+102.6
1000	-34.0	+98.8	-30.0	+102.8

FIGURE 88

REDUCED CM MF MAGNETIC FIELD STRENGTH DATA
 TAKEN IN DIRECTION OF SUNSHINE RAISE FROM
 BOTH TEST SET AND COLLINS 1-WATT RADIOS
 HECLA CON-SIL MINE

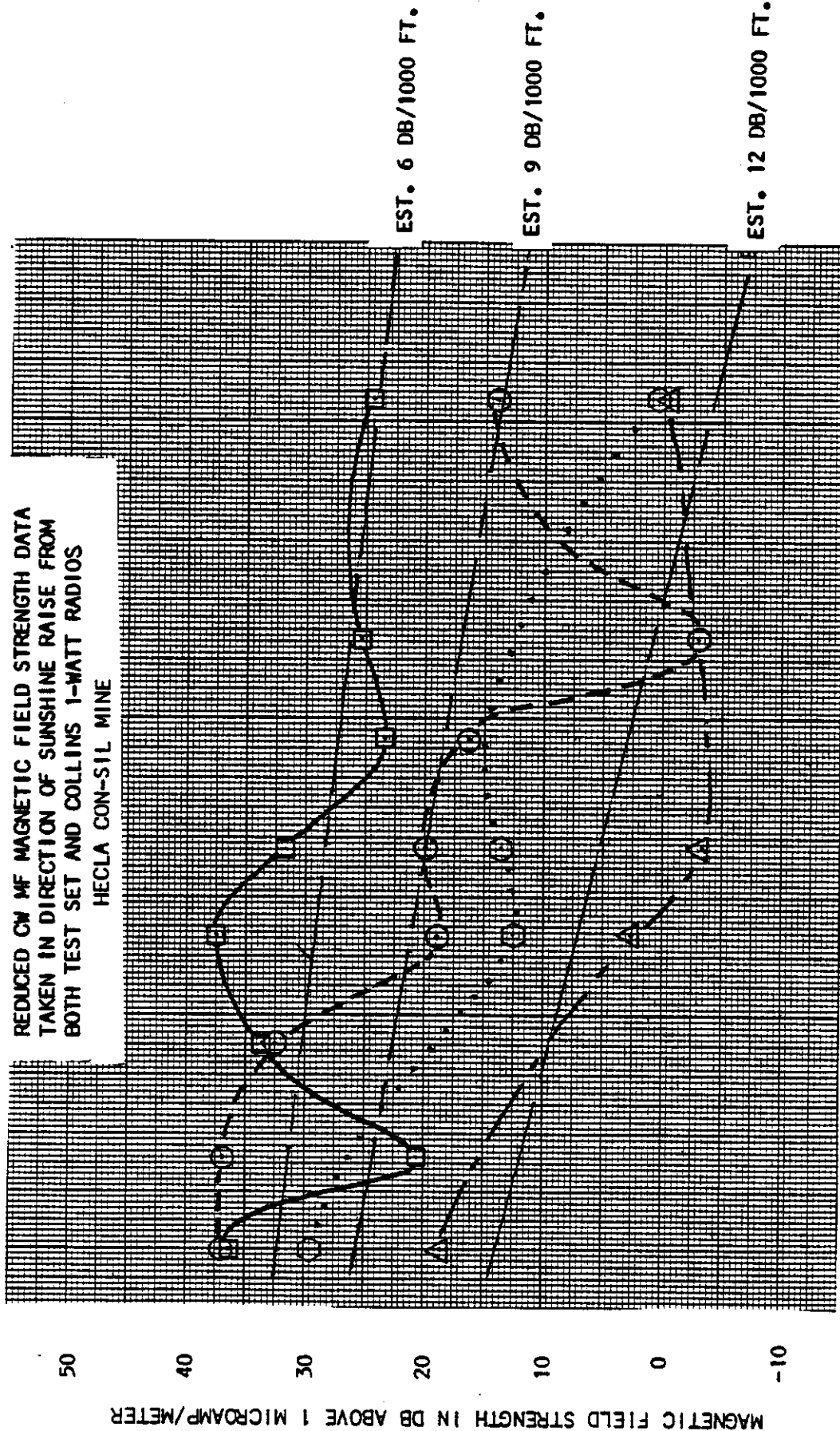

- △ --- △ 1000KHZ TEST SET
- --- ○ 650 KHZ TEST SET
- --- □ 520 KHZ TEST SET
- ◇ ◇ 300 KHZ TEST SET

FIGURE 89

REDUCED MF MAGNETIC FIELD STRENGTH DATA TAKEN
ON 3000 LEVEL TOWARD CON-SIL WINZE USING
COLLINS 520 KHZ FM RADIO AND 650 KHZ TEST SET
1 WATT TRANSMITTERS
HECLA CON-SIL MINE

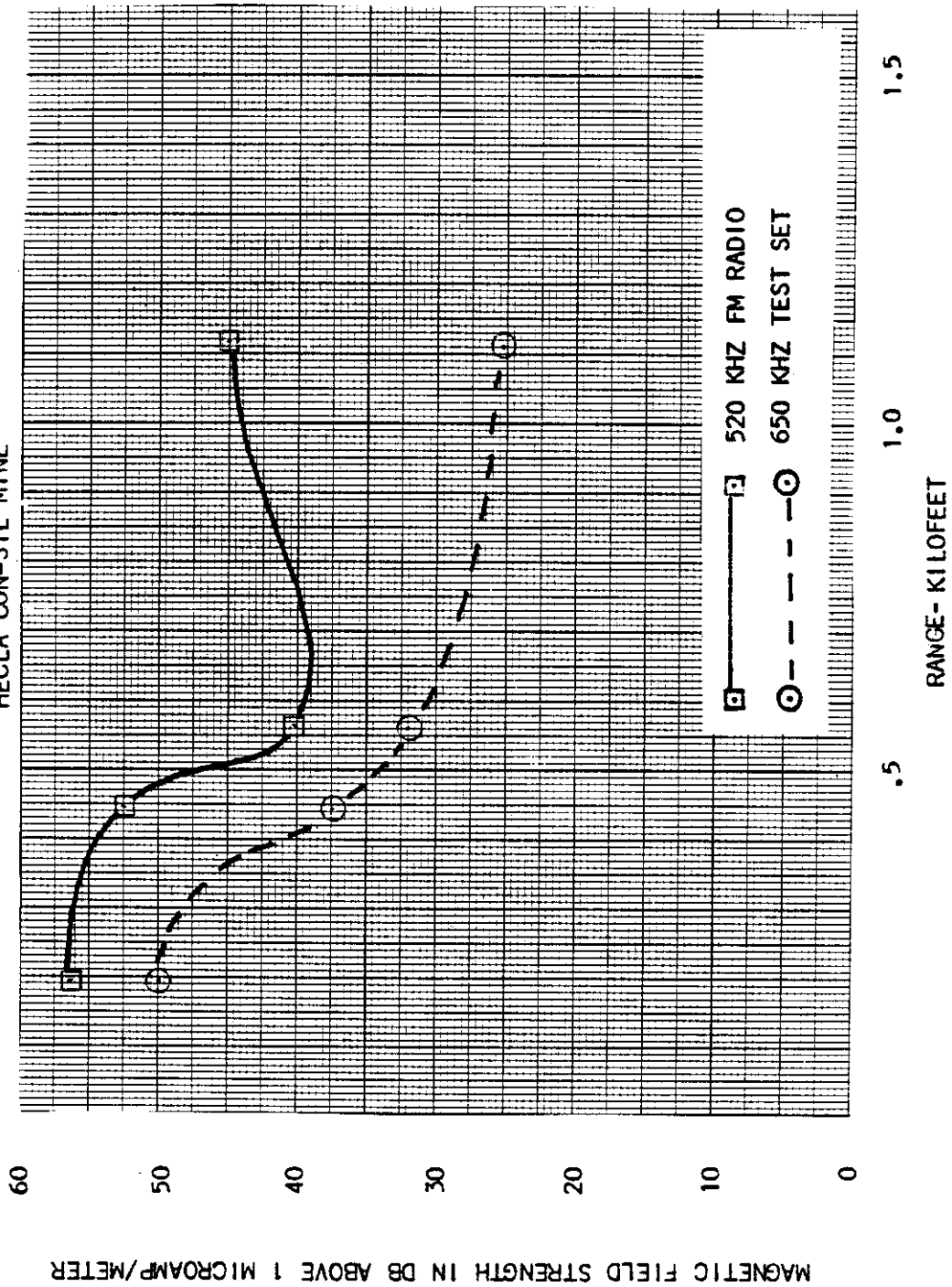

TABLE 44

REDUCED MF CW MAGNETIC FIELD STRENGTH DATA TAKEN ON A
SWEPT-FREQUENCY BASIS ON A 195 FOOT PATH IN THE 3000-LEVEL
NORTH CROSSCUT OF HECLA CON-SIL MINE USING 1 WATT TEST
SYSTEM EQUIPMENT

CURRENT PROBE REFERENCE DATA

FREQ(KHZ)	SINGER	RX(DBuV)	CF	I(DB)
300	+9.5 on +40	49.5	-	11.0 = 38.5 DBuA
520	+19.0 on +60	99.0	-	12.6 = 86.4 DBuA
650	+8.8 on +60	68.8	-	13.0 = 55.8 DBuA
1000	+18.6 on +40	58.6	-	13.5 = 45.1 DBuA

LOCA- TION	650 KHZ		520 KHZ		300 KHZ		1000KHZ	
	SINGER	H(DB)	SINGER	H(DB)	SINGER	H(DB)	SINGER	H(DB)
1	+26 on +20	+37.0	+23 on +20	+36.5	+14 on +20	+29.6	+14 on +20	+18.5
2	+26 on +20	+37.0	+ 7 on +20	+20.5				
3	+21½ on +20	+32.5	+20 on +20	+33.5				
4	+ 8 on +20	+19.0	+22 on +20	+37.5	+17 on 0	+12.6	+18 on 0	+2.5
5	+ 9 on +20	+20.0	+18.3 on +20	+31.8	+18 on 0	+13.6	+12 on 0	-3.5
6	+5.5 on +20	+16.5	+10 on +20	+23.5				
7	+ 6 on 0	-3.0	+12 on +20	+25.5				
8	+3.3 on +20	+14.3	+11 on +20	+24.5	+ 5 on 0	+0.6	+15.7 on 0	-0.3
10	+27 on -20	-2.0	+25 on -20	-1.5				
11	+26 on -20	-3.0	+14 on -20	-12.5				
A	+19 on +40	+50.0	+23 on +40	+56.5				
B	+6.5 on +40	+37.5	+19 on +40	+52.5				
C	+ 1 on +40	+32.0	+6½ on +40	+40.0				
D	+14 on +20	+25.0	+11½ on +40	+45.0				
E	+ 7 on 0	-2.0	+24 on 0	+17.5				
F	+4.5 on +20	+15.5	+21 on +20	+34.5				

FIGURE 90

PROCESSED MF AND HF DATA FROM HECLA CON-SIL MINE ON 429-FOOT
TEST RANGE FOR FLAT NIA OF -2 DB WITH AND WITHOUT ATTENUATION
DATA OBTAINED USING TEST SYSTEM EQUIPMENT

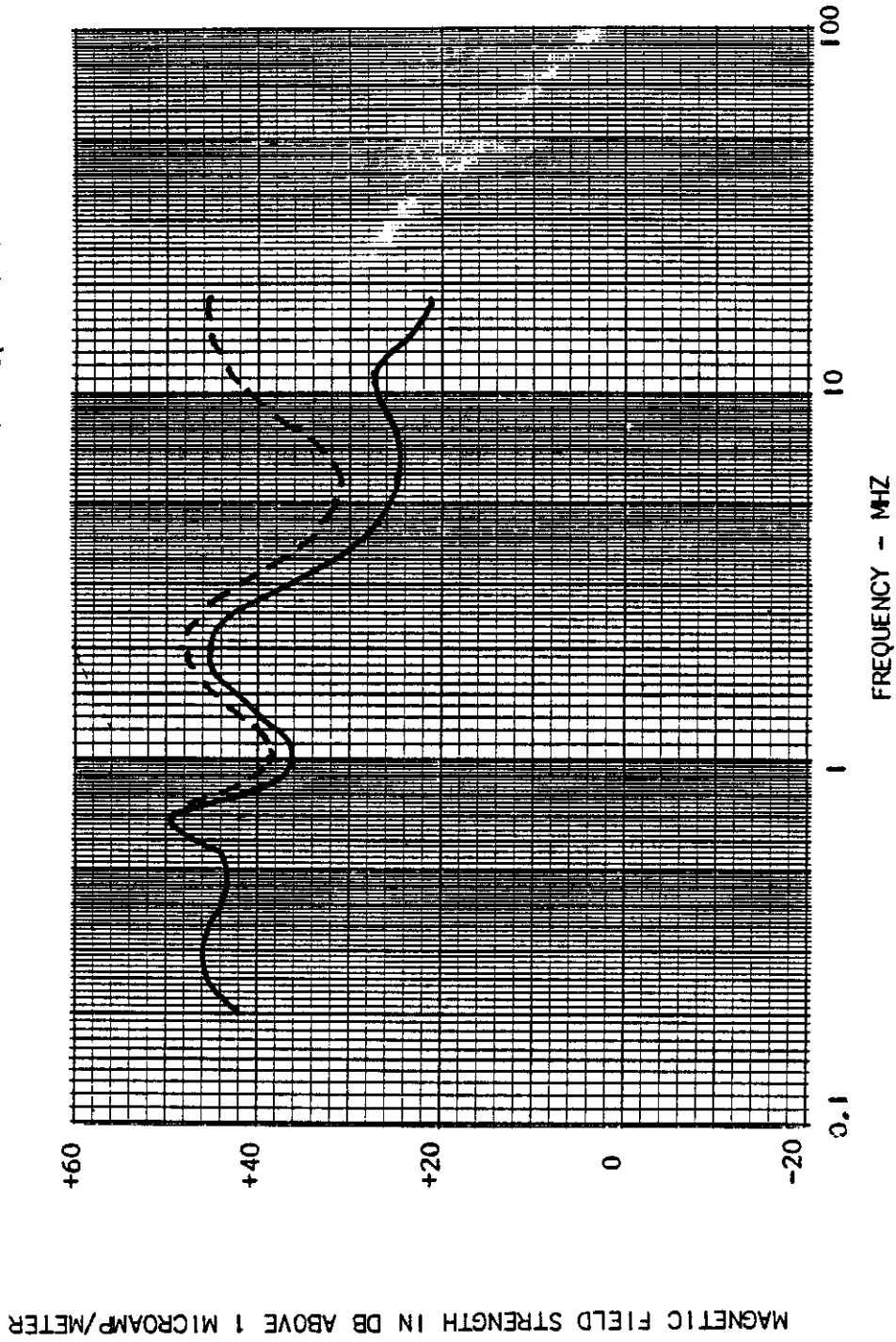

5.0 PRESENTATION OF RAW SWEEP-FREQUENCY DATA

This section presents all the raw swept-frequency oscillographs taken during the program in the individual mines. Raw CW data have been presented in tabular form in conjunction with their reduced counterparts in Section 4.0.

5.1 RAW DATA FROM OCCIDENTAL LOGAN WASH MINE

The MF data taken at test ranges of 120 and 240 feet is given in Figure 91.

The HF data taken at a test range of 120 feet is given in Figure 92.

The VHF data taken at test ranges of 120 and 240 feet is shown in Figures 93 and 94 respectively for vertical and horizontal polarization with axial polarization data being shown for the 240-foot range in Figure 95.

The UHF data taken at the 240-foot test range is given in Figures 96 and 97 respectively for vertical and horizontal polarization.

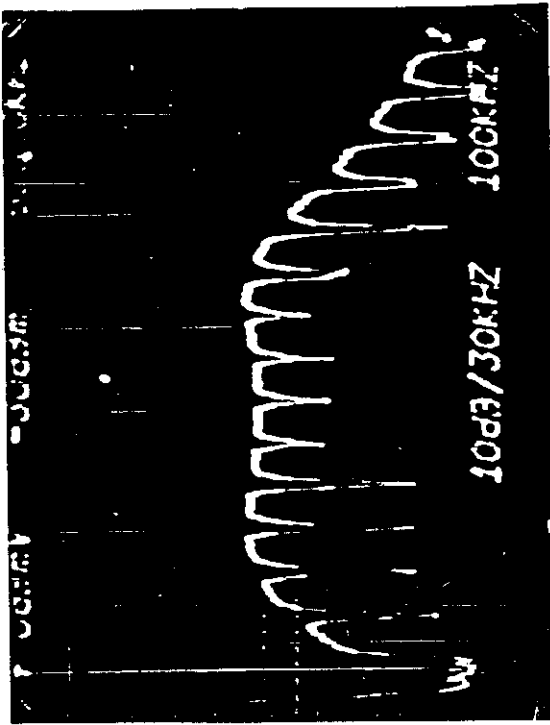

VERTICAL HMD
(120 FEET)

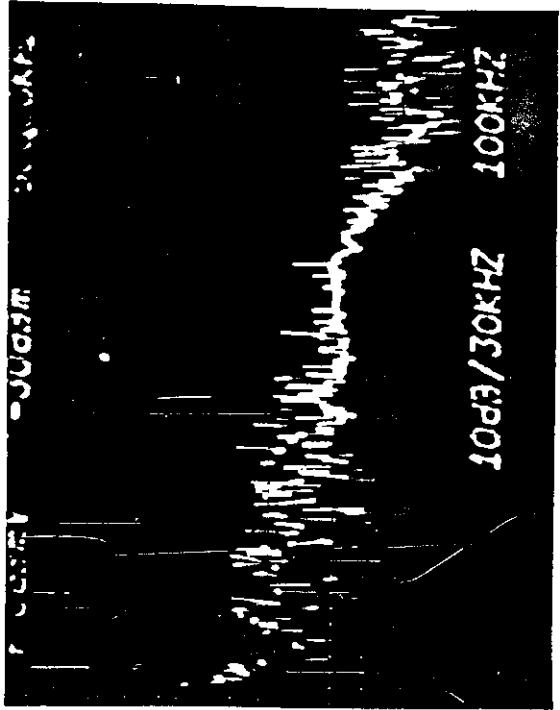
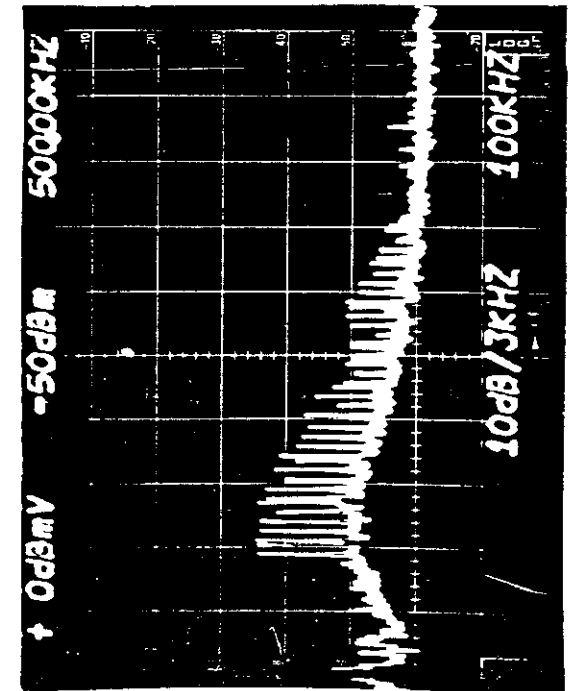

LEFT: COPLANAR HMD
(240 FEET)

RIGHT: VERTICAL XMIT.
HORIZONTAL RCV.
(120 FEET)

FIGURE 91

MEDIUM FREQUENCY SWEPT FIELD STRENGTH

ORIGINAL OSCILLOGRAPH LOGAN WASH MINE

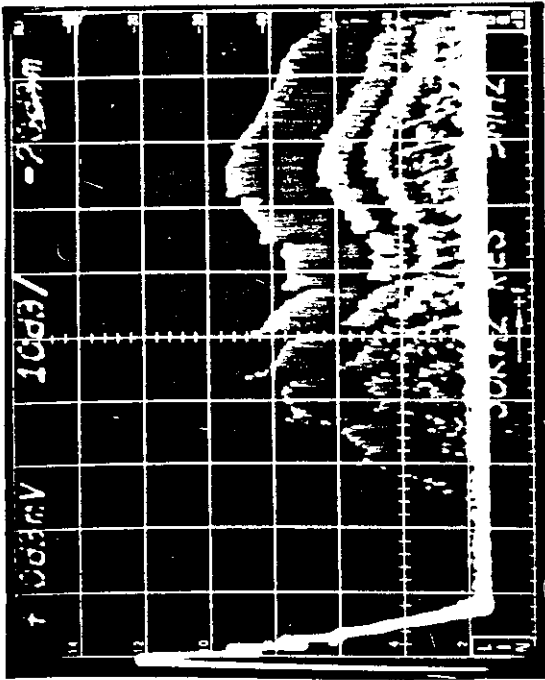

LEFT: COPLANAR
HMD (120 FEET)

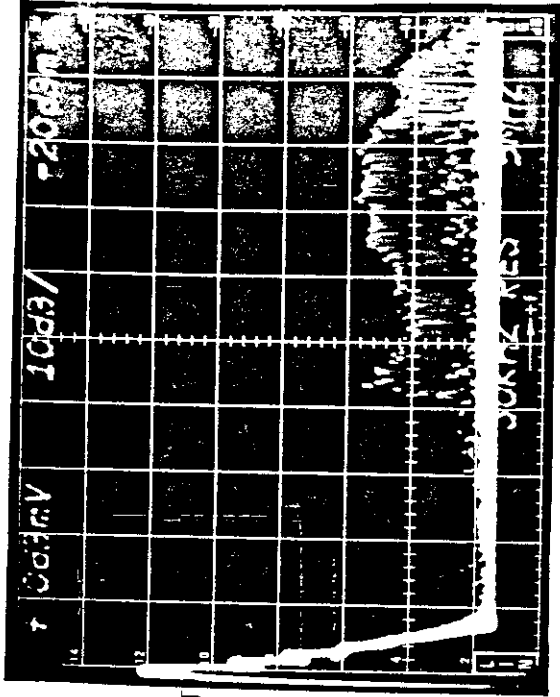

RIGHT: AXIAL HMD
(120 FEET)

FIGURE 92
HIGH FREQUENCY SWEEP FIELD
STRENGTH ORIGINAL OSCILLOGRAPHS
LOGAN WASH MINE

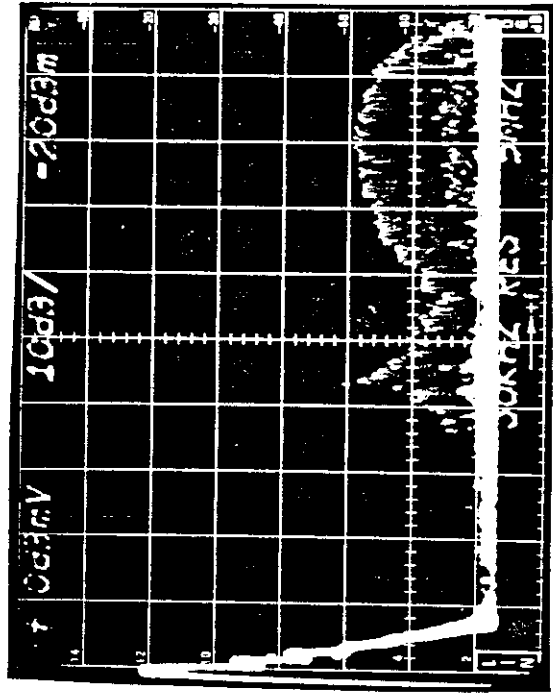

LEFT: COPLANAR VMD
(120 FEET)

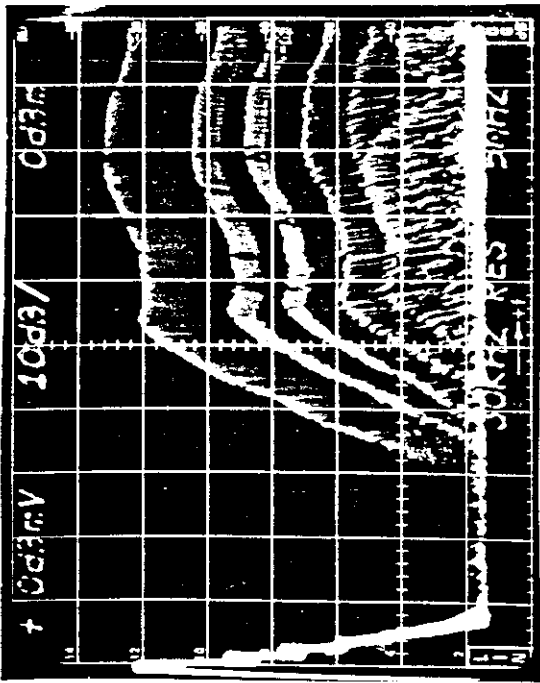

UPPER: VERTICAL
POLARIZATION
(120 FEET)

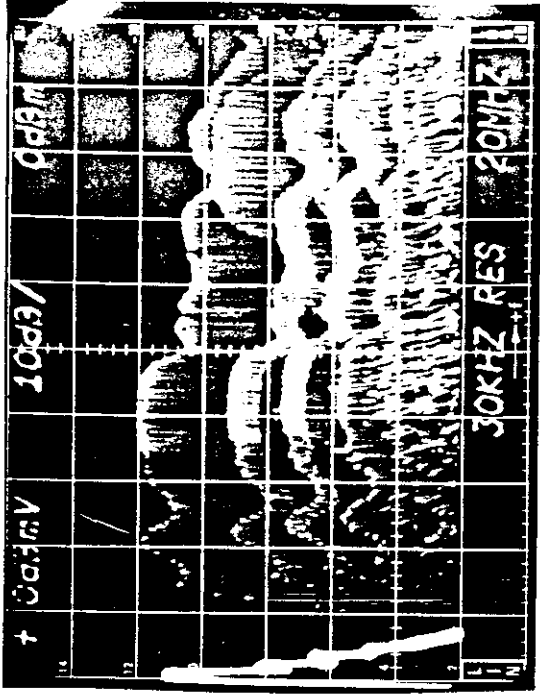

LOWER: VERTICAL
POLARIZATION
(240 FEET)

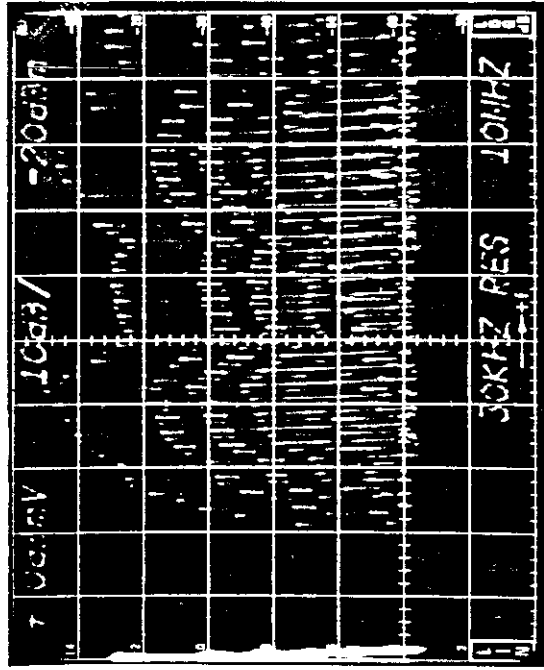
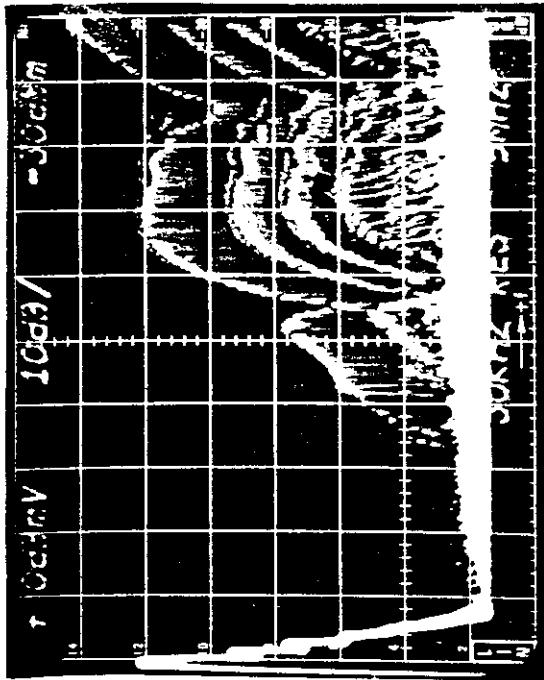
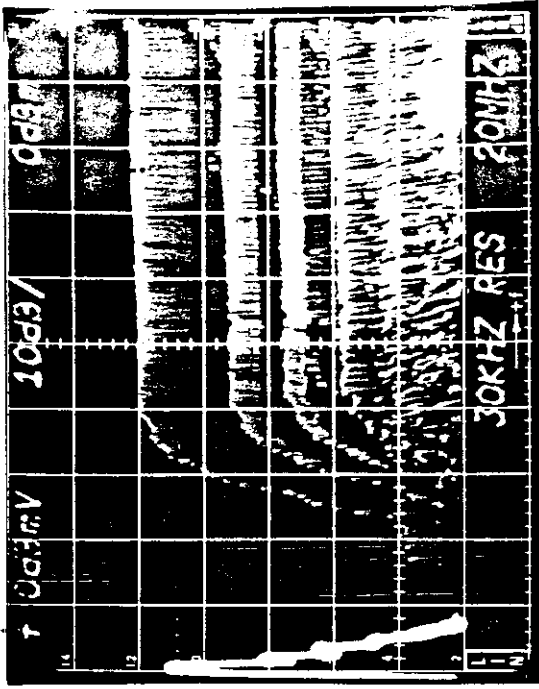

FIGURE 93
VHF SWEEP FREQUENCY FIELD STRENGTH ORIGINAL
OSCILLOGRAPHS LOGAN WASH MINE



UPPER: HORIZONTAL
POLARIZATION
(120 FEET)



LOWER: HORIZONTAL
POLARIZATION
(240 FEET)

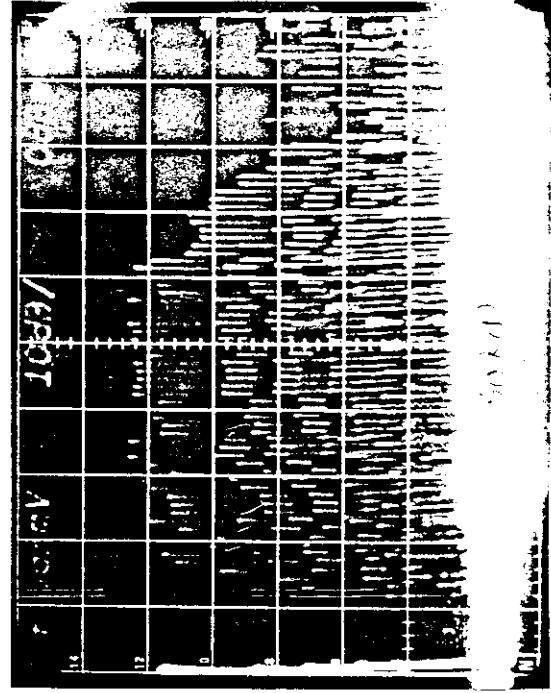
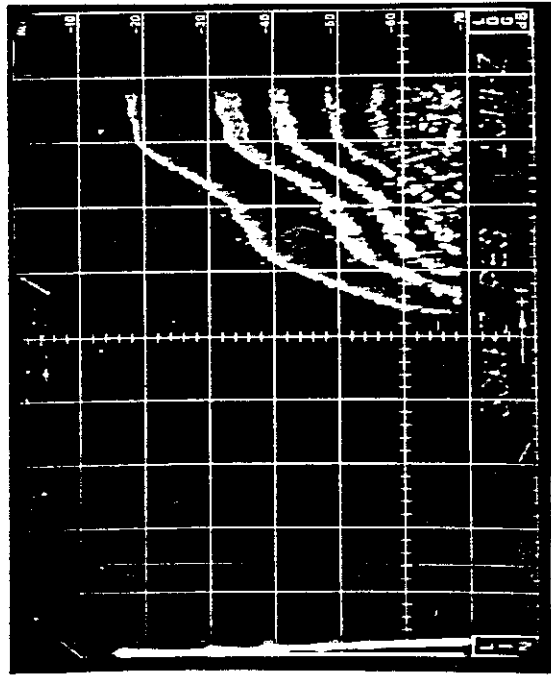
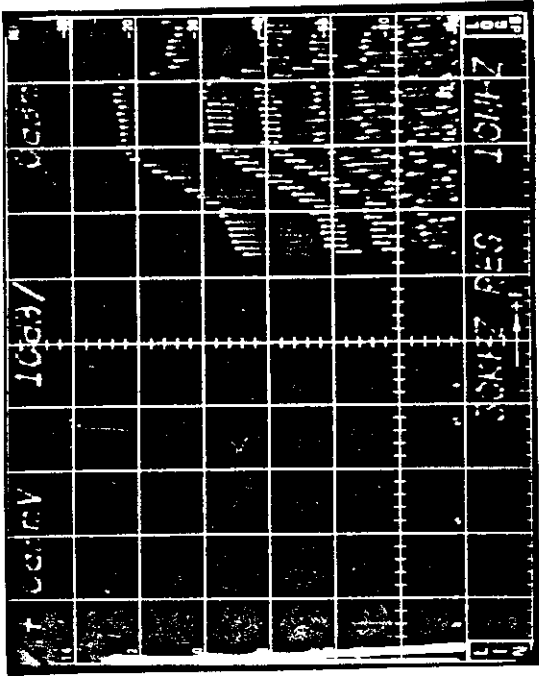

FIGURE 94
VHF SWEPT FREQUENCY FIELD STRENGTH ORIGINAL
OSCILLOGRAPHS LOGAN WASH MINE



AXIAL POLARIZATION
(240 FEET)

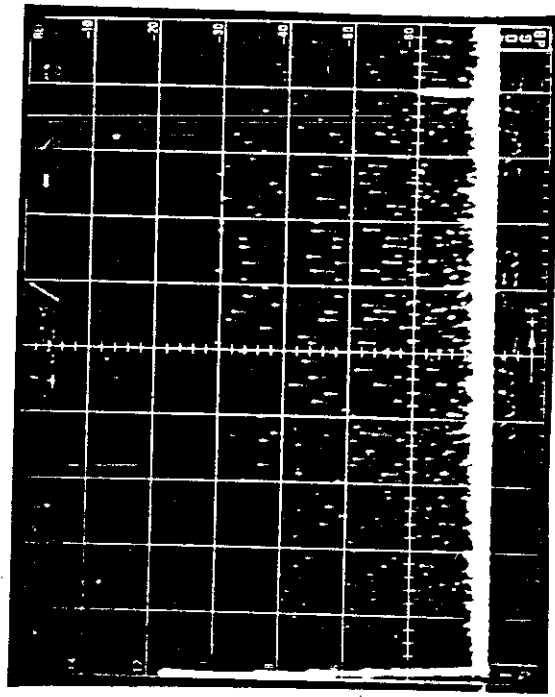
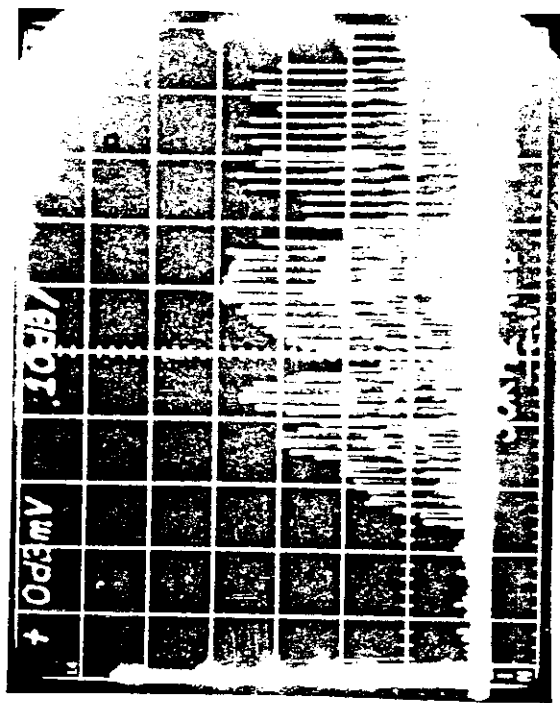
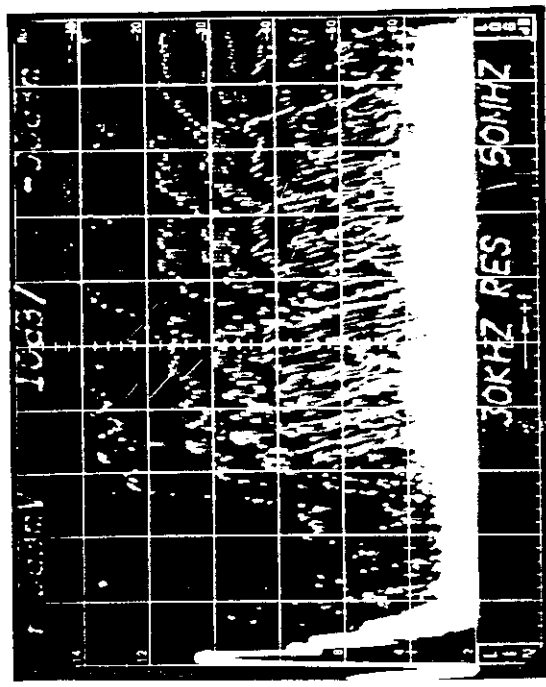
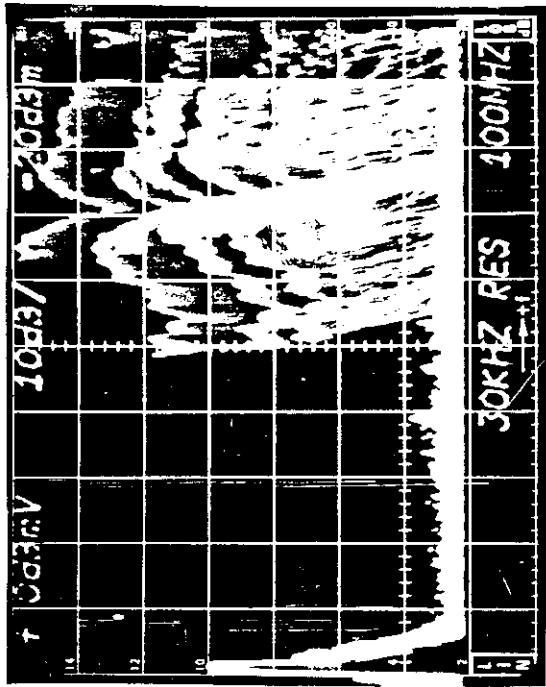
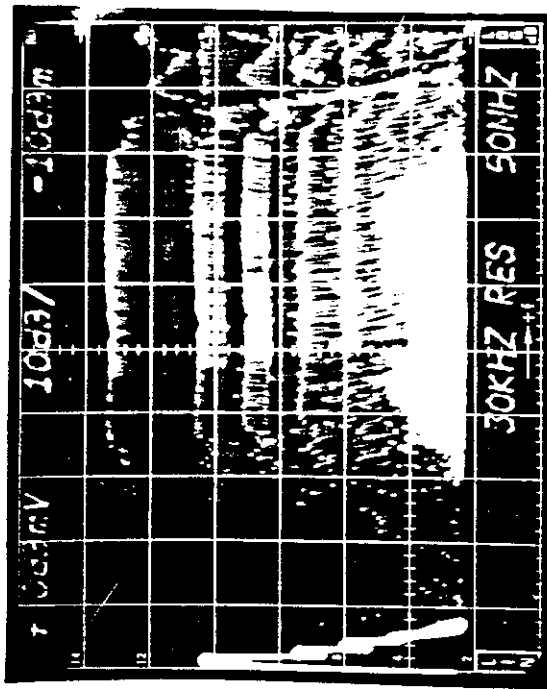

FIGURE 95
VIF SWEPT FREQUENCY FIELD STRENGTH ORIGINAL
OSCILLOGRAPHS LOGAN WASH MINE



VERTICAL POLARIZATION (240 FEET)

FIGURE 96
 UHF SWEEP FREQUENCY FILLED STRIP: ORIGINAL
 OSCILLOGRAPHS LOGAN WASH MINE



HORIZONTAL
POLARIZATION
(240 FEET)

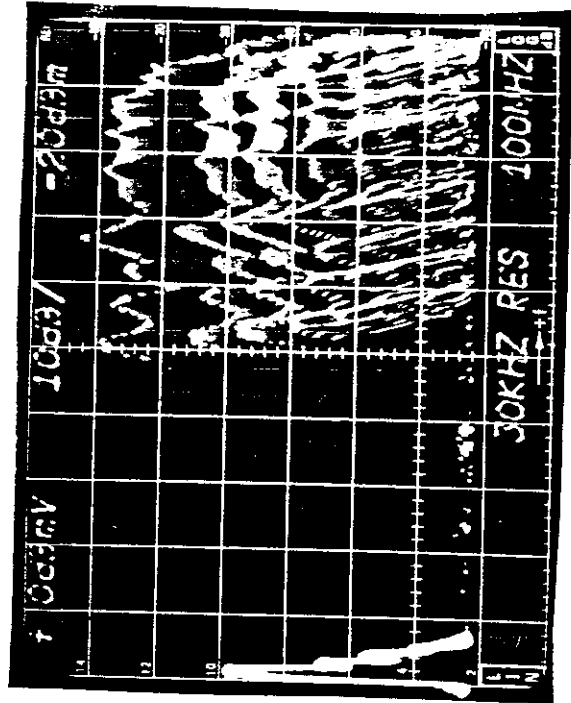
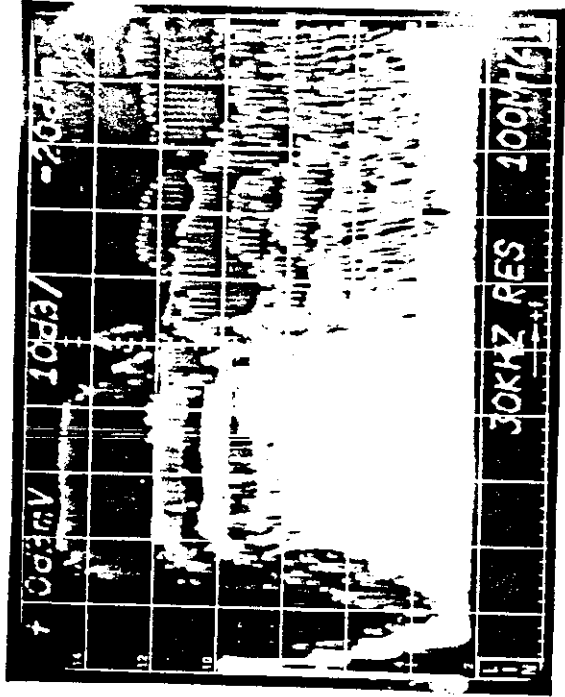

FIGURE 97
UHF SWEEP FREQUENCY FIELD STRENGTH ORIGINAL
OSCILLOGRAPHS LOGAN WASH MINE

5.2 RAW DATA FROM UNITED NUCLEAR/HOMESTAKE PARTNERS SECTION 23 MINE

The MF data taken in the Wagner and 650 track test areas is given respectively in Figures 98 and 99.

The HF data taken in the Wagner test area is given in Figure 100.

The VHF data taken in the Wagner and 650 track test areas is given respectively in Figures 101 and 102.

The UHF data taken in the Wagner and 650 track test areas is given respectively in Figures 103 and 104.

FIGURE 98

ORIGINAL OSCILLOGRAPHS OF MF SWEEP-FREQUENCY
DATA TAKEN IN WAGNER AREA OF UNITED NUCLEAR
SECTION 23 MINE

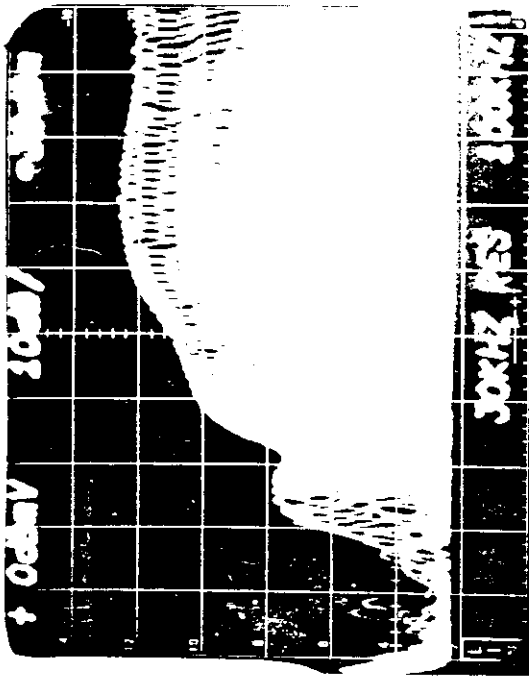

TX CURRENT PROBE - RX ANTENNA UNDER 480 VAC
LINE 1.5 METERS CENTER-CENTER

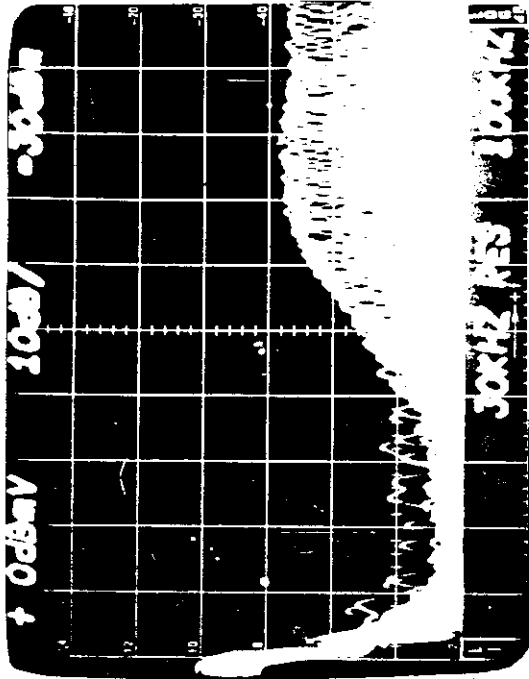

TX ANTENNA - TX AND RX ANTENNAS UNDER 480 VAC
LINE 1.5 METERS CENTER-CENTER

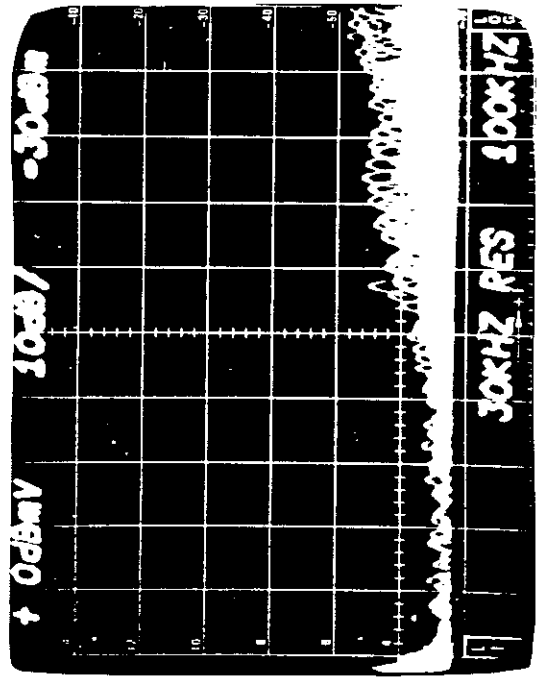

TX ANTENNA - TX ANTENNA 1.5 METERS UNDER 480
VAC LINE - RX ANTENNA 2.6 M @ DRIFT CENTER

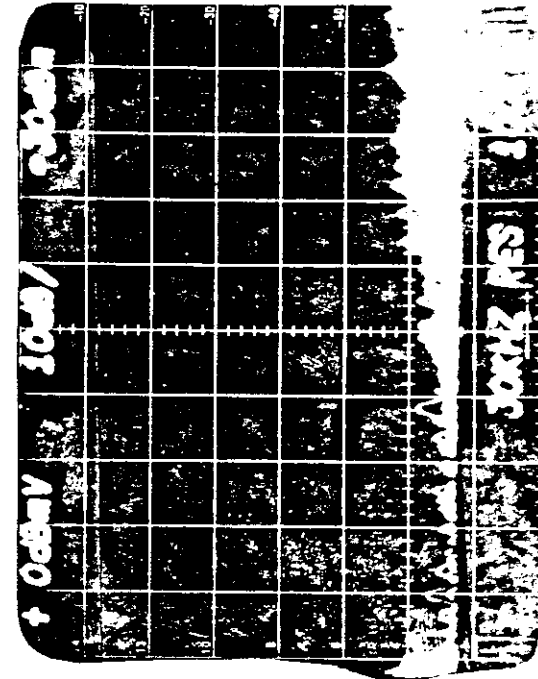

TX ANTENNA - TX & RX ANTENNAS AXIAL ORIENTA-
TION - TX ANTENNA 1.5 METERS UNDER 480 VAC
LINE - RX ANTENNA 2.6 METERS @ DRIFT CENTER

FIGURE 99

ORIGINAL OSCILLOGRAPHS OF MF SWEEP-FREQUENCY
DATA TAKEN IN 650 TRACK AREA OF UNITED NUCLEAR
SECTION 23 MINE

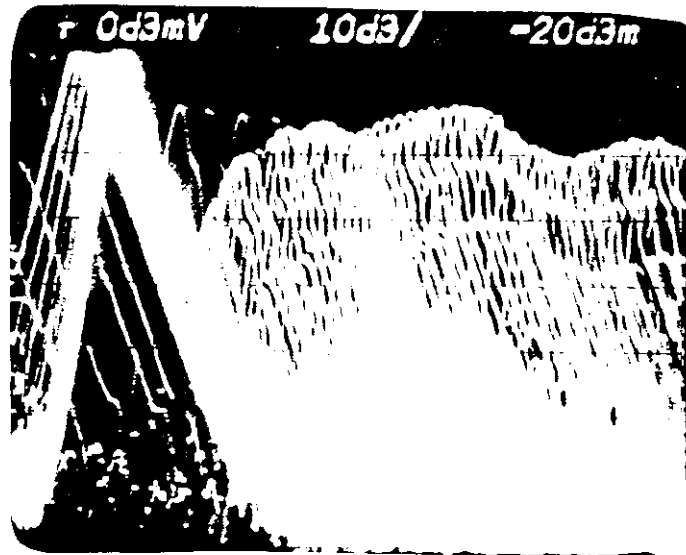

TX CURRENT PROBE - RX ANTENNA WITH FLAT SIDE
AGAINST MESH 0.3 METERS CENTER-CENTER

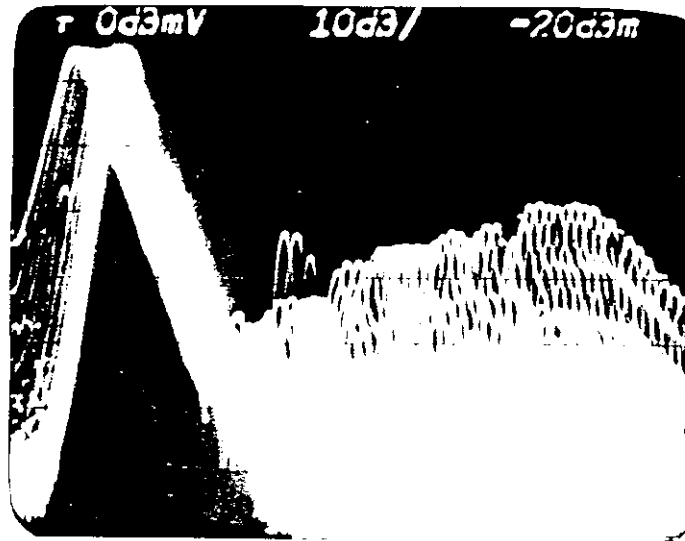

TX ANTENNA - TX ANTENNA IN DRIFT CENTER 4.5
METERS CENTER-CENTER - RX ANTENNA WITH FLAT
SIDE AGAINST MESH 0.3 METERS CENTER-CENTER

NOTE: CURRENT PROBE ON PHONE LINE

FIGURE 100

ORIGINAL OSCILLOGRAPHS OF HF SWEPT-FREQUENCY
DATA TAKEN IN WAGNER AREA OF SECTION 23 MINE

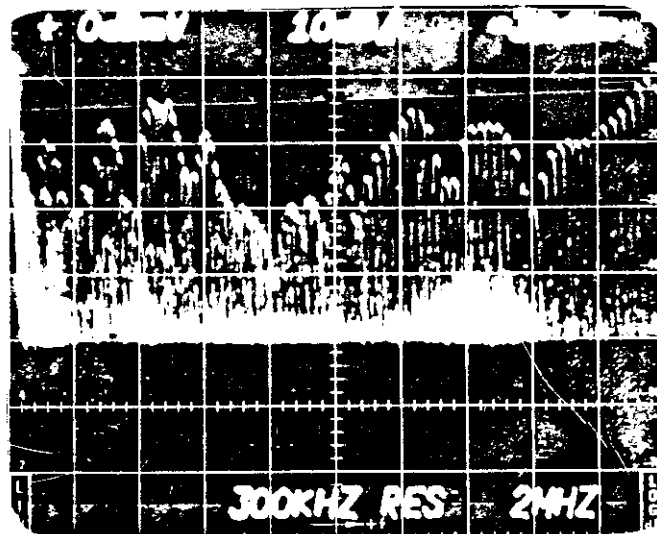

TX CURRENT PROBE - RX ANTENNA UNDER 480 VAC
LINE 1.5 METERS CENTER-CENTER

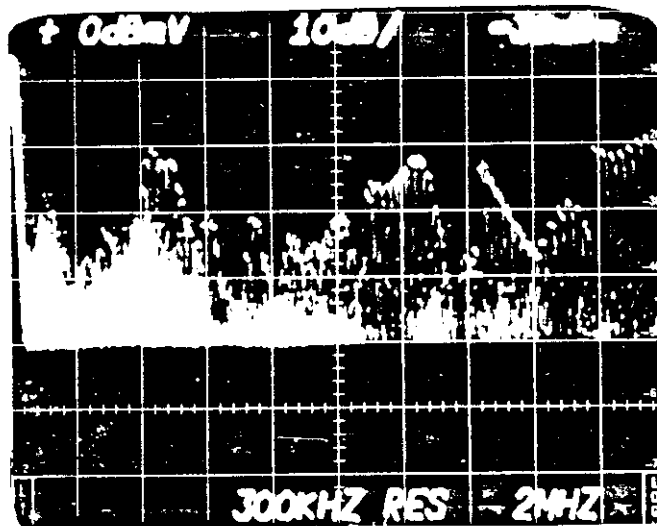

TX ANTENNA 1.5 METERS CENTER-CENTER UNDER
480 VAC CABLE - RX ANTENNA TIP ON CABLE
0.6 METERS CENTER-CENTER

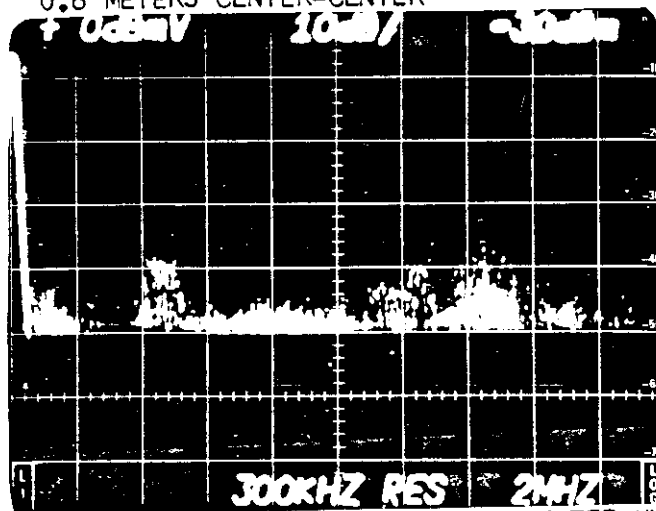

TX ANTENNA 1.5 METERS CENTER-CENTER UNDER
480 VAC CABLE - RX ANTENNA AT DRIFT CENTER
2.6 METERS CENTER-CENTER SPACING

FIGURE 101

ORIGINAL OSCILLOGRAPHS OF VHF SWEPT-FREQUENCY
DATA TAKEN IN WAGNER AREA OF UNITED NUCLEAR
SECTION 23 MINE

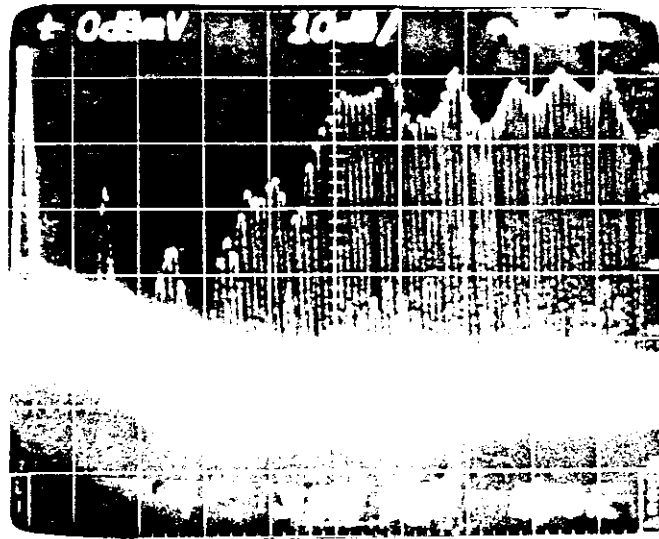

HORIZONTAL BROADSIDE ORIENTATION

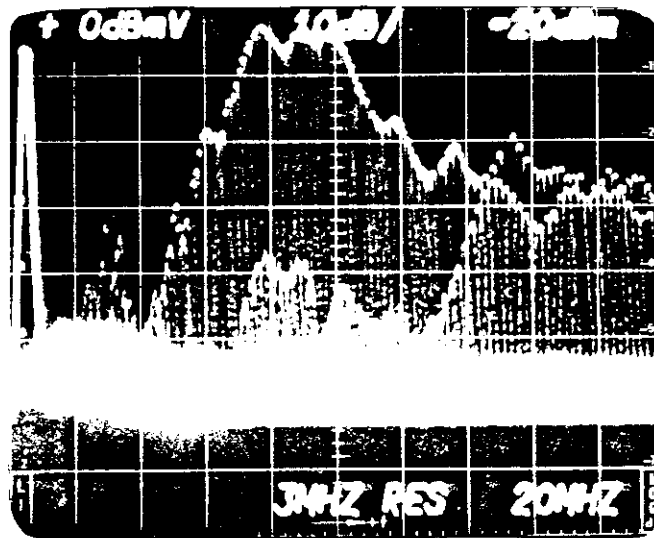

VERTICAL ORIENTATION

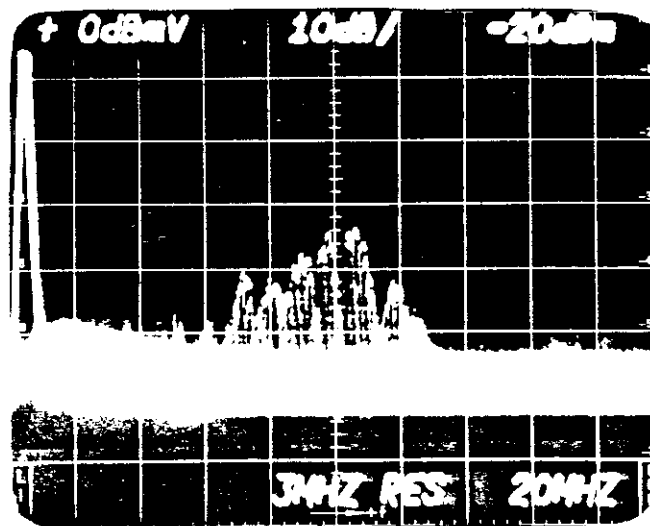

HORIZONTAL COLLINEAR ORIENTATION

FIGURE 102

ORIGINAL OSCILLOGRAPHS OF VHF SWEPT-FREQUENCY
DATA TAKEN IN 650 TRACK AREA OF UNITED NUCLEAR
SECTION 23 MINE

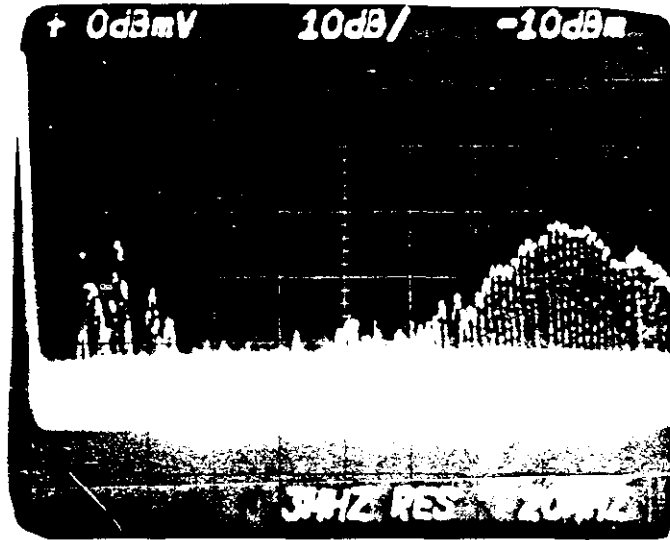

VERTICAL ORIENTATION



HORIZONTAL BROADSIDE ORIENTATION

FIGURE 103

ORIGINAL OSCILLOGRAPHS OF UHF SWEPT-FREQUENCY
DATA TAKEN IN WAGNER AREA OF UNITED NUCLEAR
SECTION 23 MINE

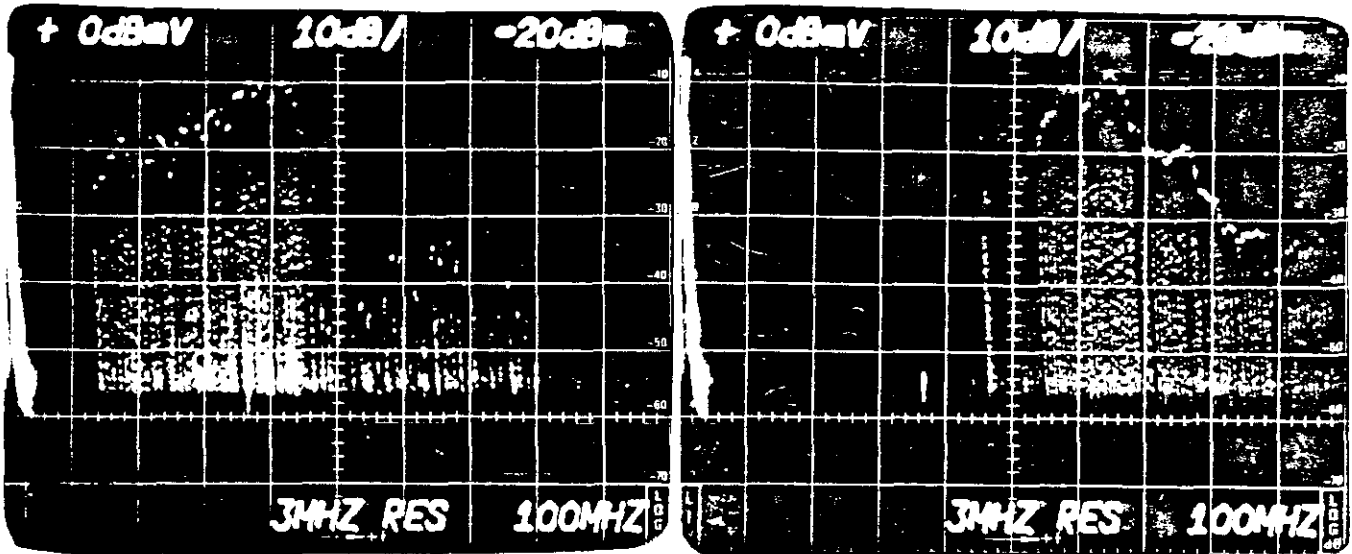

HORIZONTAL BROADSIDE ORIENTATION

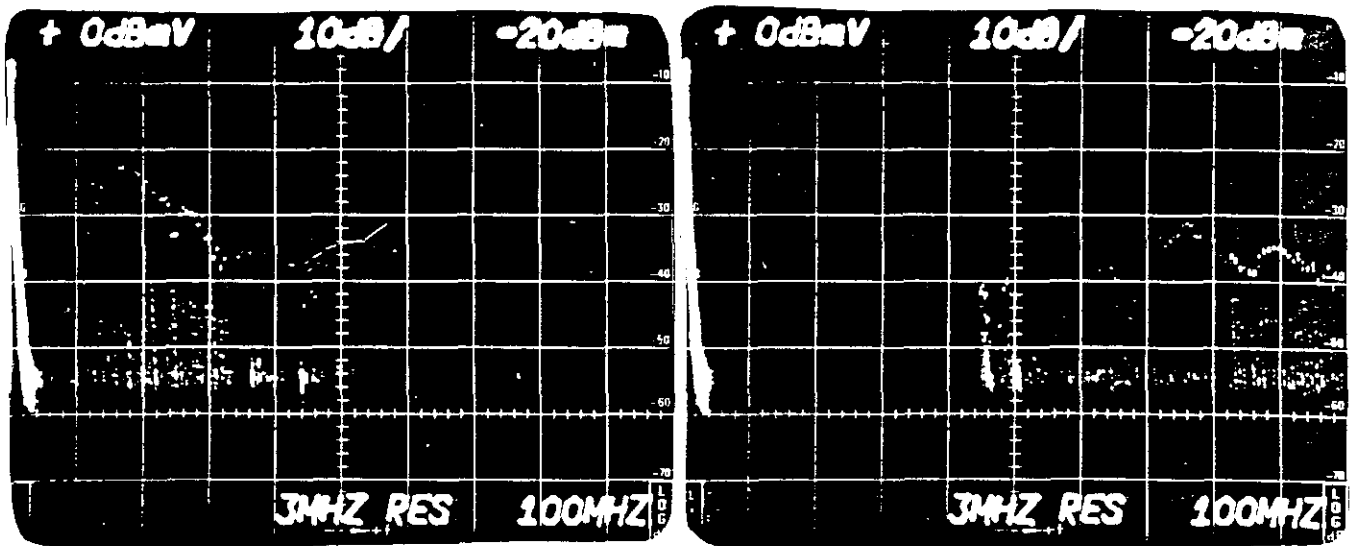

VERTICAL ORIENTATION

FIGURE 104

ORIGINAL OSCILLOGRAPHS OF UHF SWEPT-FREQUENCY
DATA TAKEN IN 650 TRACK AREA OF UNITED NUCLEAR
SECTION 23 MINE



HORIZONTAL BROADSIDE ORIENTATION



VERTICAL ORIENTATION

5.3 RAW DATA FROM KERR-MCGEE HOBBS POTASH FACILITY MINE

The MF data taken at the 150 and 300 foot test ranges is given respectively in Figures 105 and 106.

The HF data taken at the 150 and 300 foot test ranges is given respectively in Figures 107 and 108.

The VHF data taken at the 150 and 300 foot test ranges is given respectively in Figures 109 and 110.

The UHF data taken at the 150 and 300 foot test ranges is given respectively in Figure 111.

The MF current probe coupled data at 300 foot test range is shown in Figure 112.

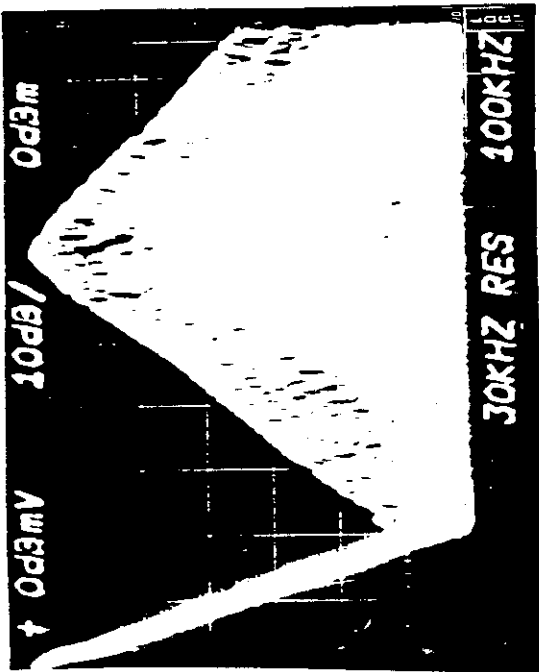

LEFT: COPLANAR HMD

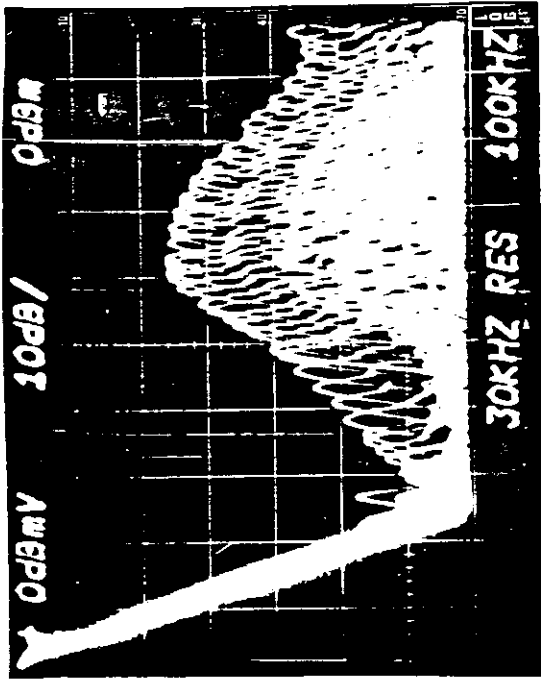

RIGHT: COPLANAR VMD

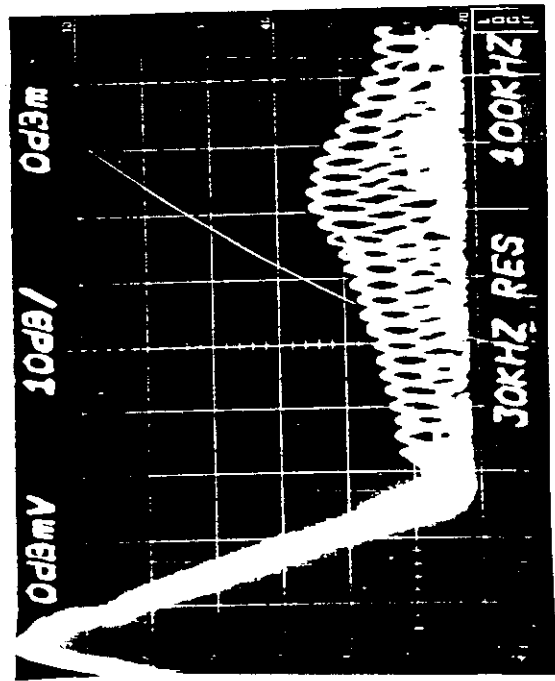

COAXIAL HMD

FIGURE 105
 MEDIUM FREQUENCY SWEPT FIELD STRENGTH
 ORIGINAL OSCILLOGRAPHS - KERR MCGEE
 HOBBS POTASH FACILITY
 150 FEET RANGE

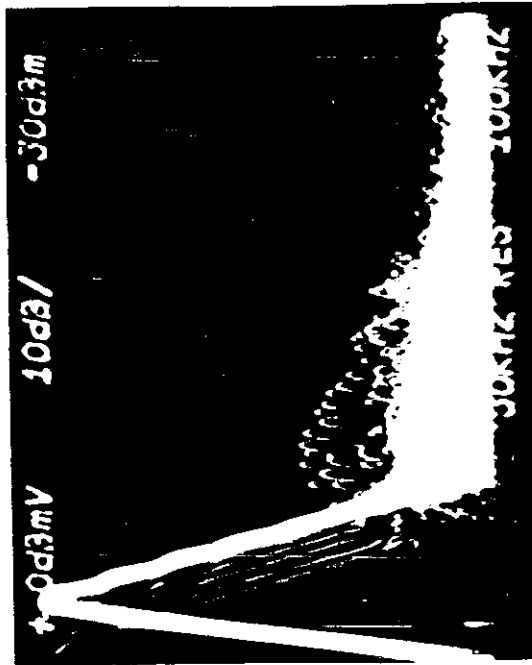

LEFT: COPLANAR
HMD

RIGHT: COPLANAR
VMD

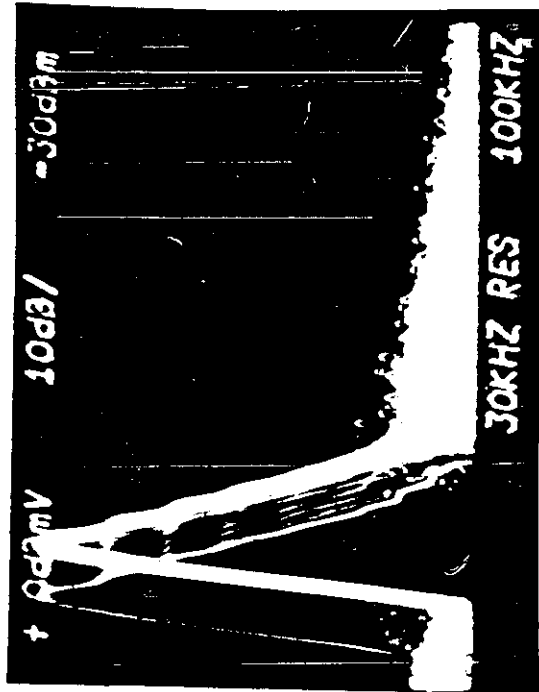
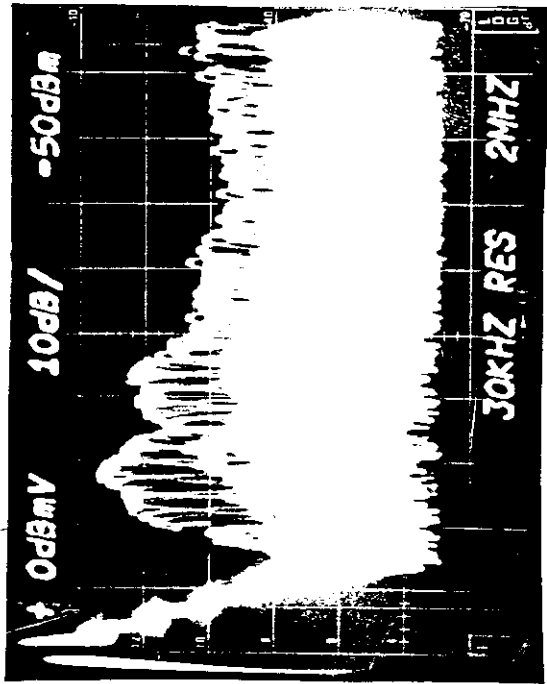
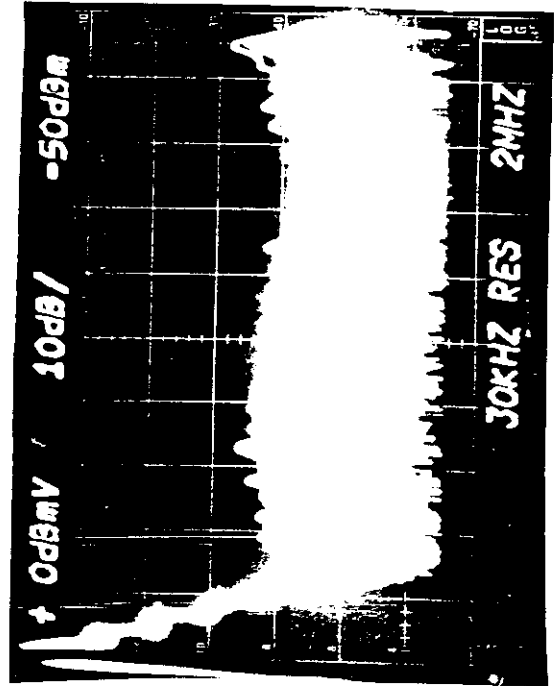
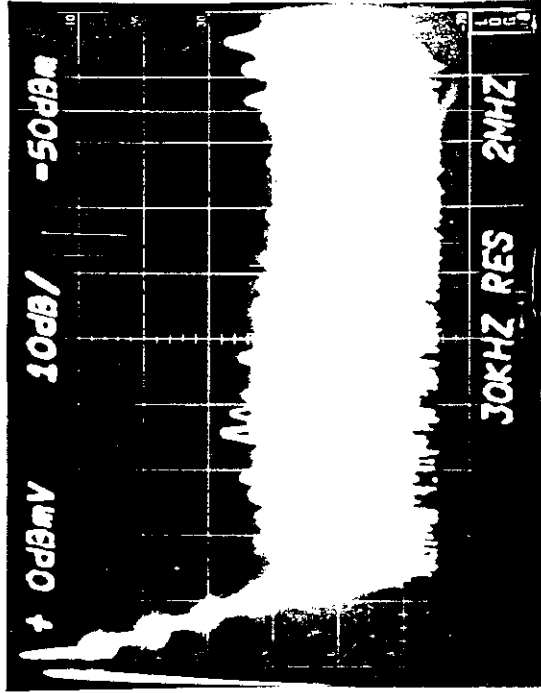

FIGURE 106
MEDIUM FREQUENCY SWEEPED FIELD STRENGTH
ORIGINAL OSCILLOGRAPHS - KERR MCGEE
HOBBS POTASH FACILITY
300 FEET RANGE



LEFT: COPLANAR HMD

RIGHT: COPLANAR VMD



LEFT: COAXIAL

RIGHT: RECEIVER NOISE

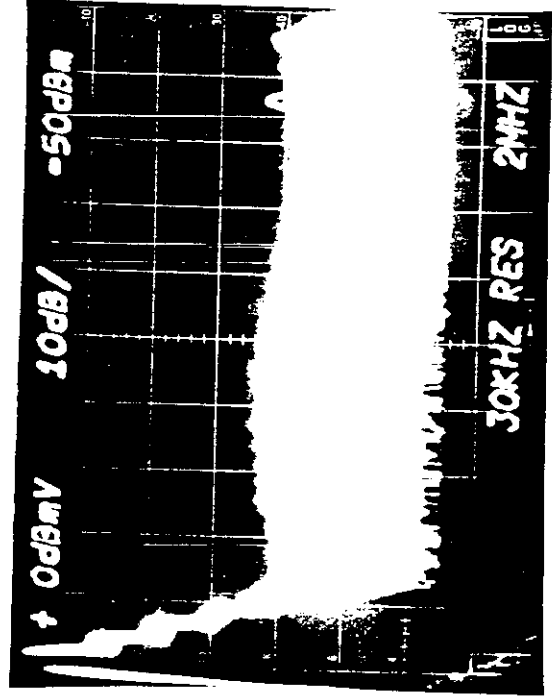
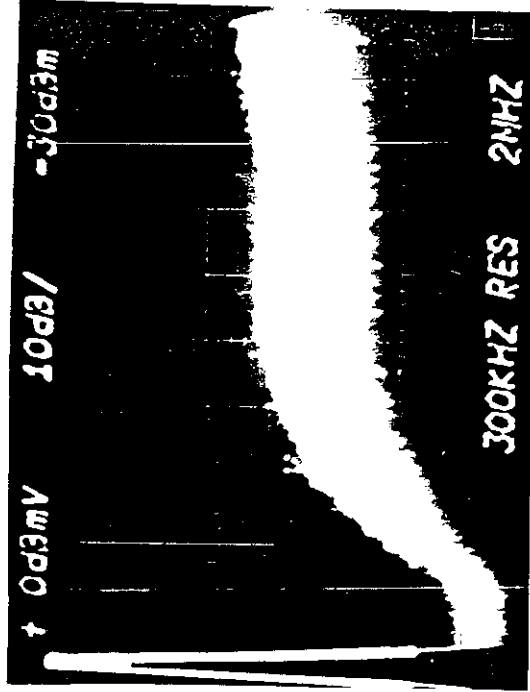
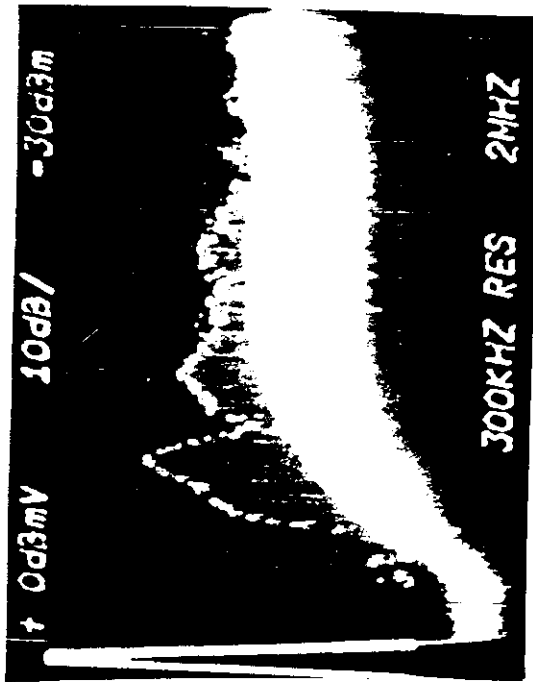

FIGURE 107
 HIGH FREQUENCY SWEEP FIELD STRENGTH - ORIGINAL OSCILLOGRAPHS - KERR MCCOY HORBS POTASH FACILITY
 150 FEET RAUCE



HMD

VMD

FIGURE 108

HIGH FREQUENCY SWEPT FIELD STRENGTH ORIGINAL OSCILLOGRAPHS
 KERR-MCGEE HORBS POTASH FACILITY NINE 300 FEET RANGE

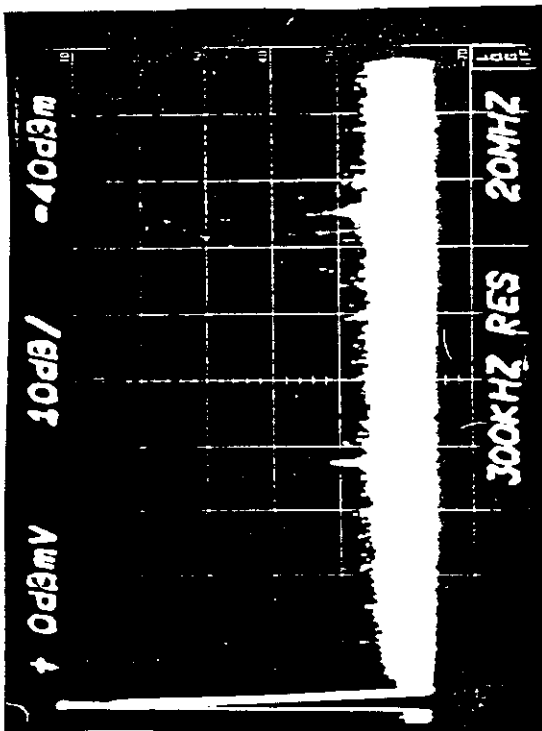

LEFT: HORIZ.
POLARIZ.

RIGHT: VERTICAL
POLARIZ.

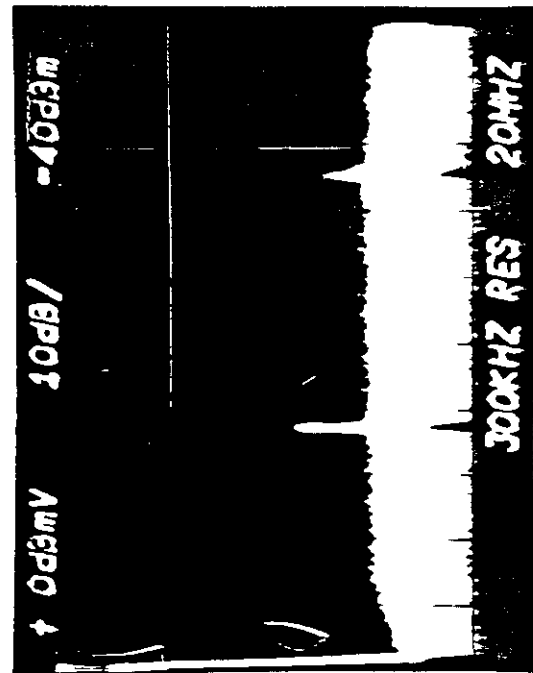
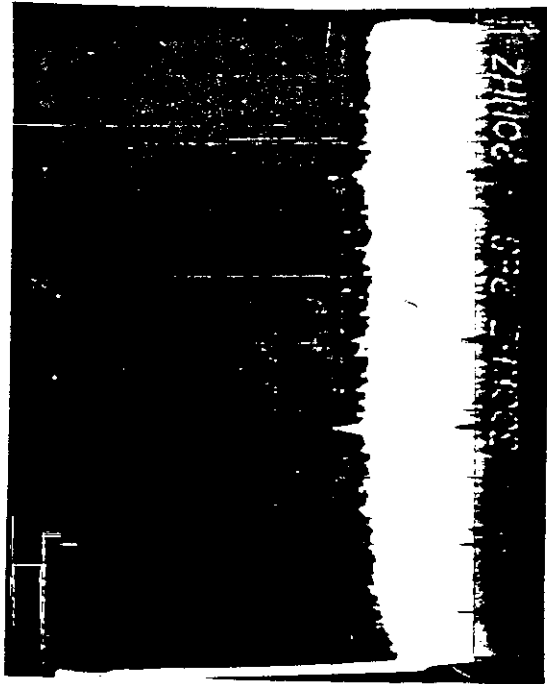

LEFT: COAXIAL

RIGHT: ORTHOG.

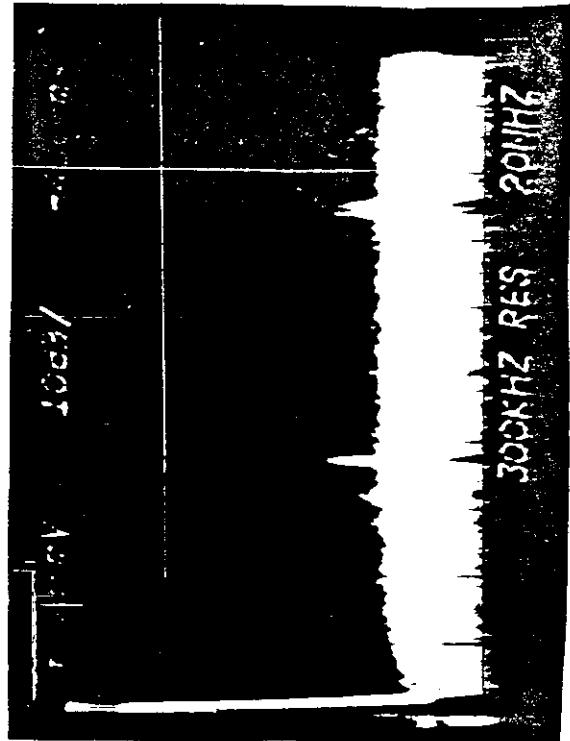
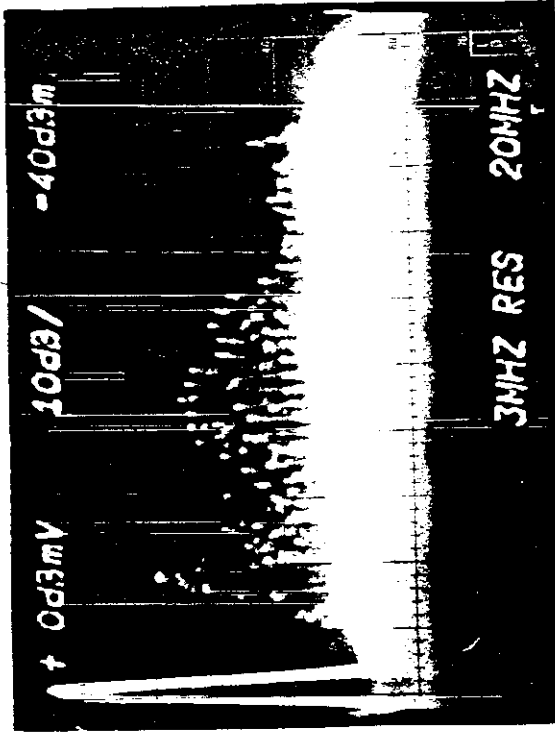

FIGURE 109
VHF SWEEPED FREQUENCY FIELD STRENGTH ORIGINAL
OSCILLOGRAPHS - KERR MCGEE HOBBS POTASH FACILITY
150 FEET RANGE

HORIZONTAL POLARIZATION



VERTICAL POLARIZATION

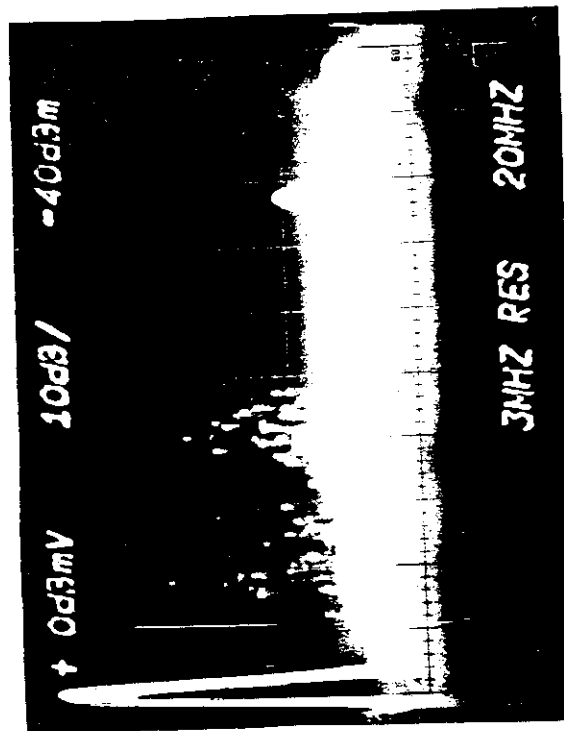
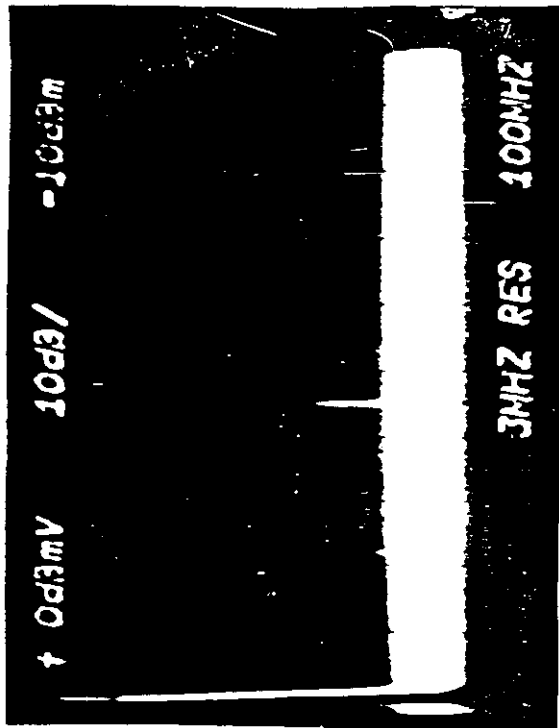
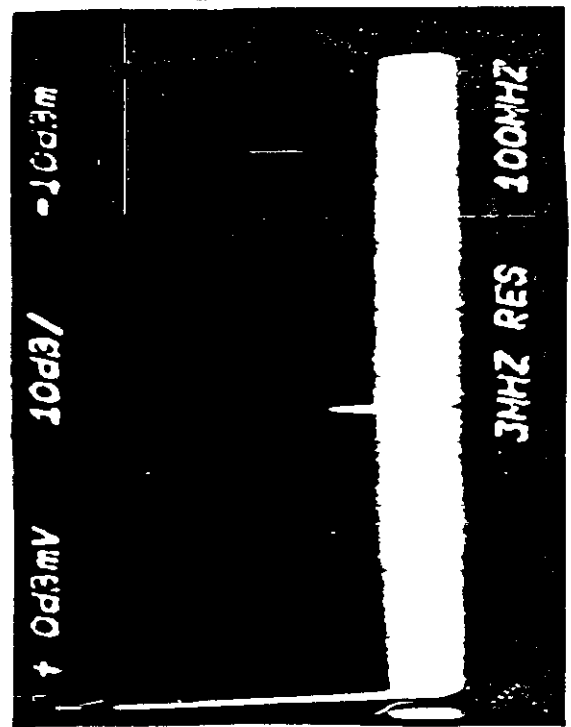

FIGURE 110
VHF SWEPT FREQUENCY FIELD STRENGTH ORIGINAL
OSCILLOGRAPHS -- KERR MCGEE HOBBS POTASH FACILITY
300 FEET RANGE



VERTICAL
POLARIZATION

0 TO 500MHZ



HORIZONTAL
POLARIZATION

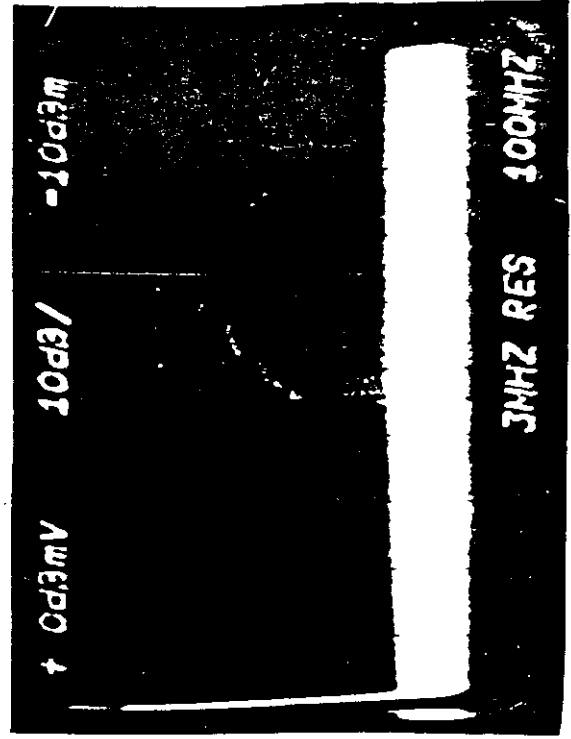

500 TO 1000 MHZ

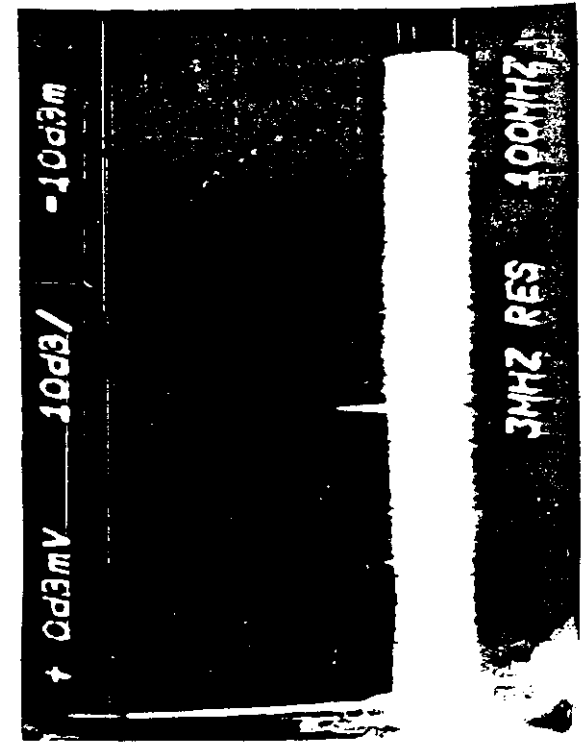

UHF SWEEPED FREQUENCY FIELD STRENGTH ORIGINAL
OSCILLOGRAPHS - KERR MCGEE HOBBS POTASH FACILITY
150 FEET RANGE

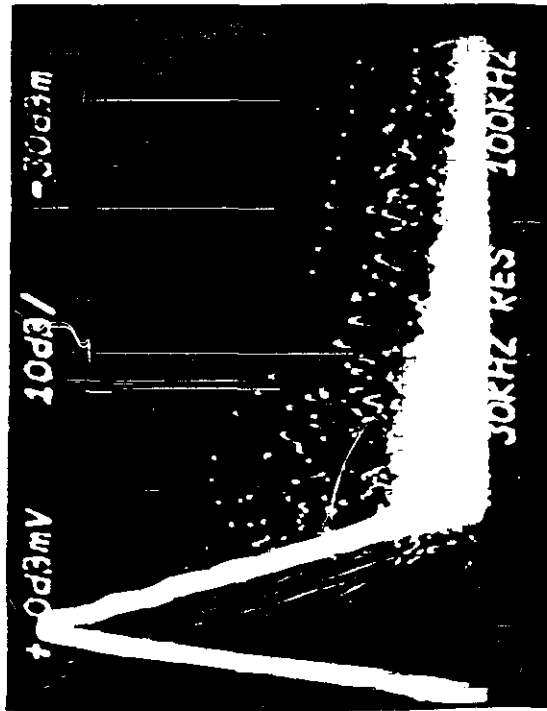

FIGURE 112
 MEDIUM FREQUENCY SWEEPED FIELD STRENGTH ORIGINAL OSCILLOGRAPHS
 KERR MCGEE HOBBS POTASH FACILITY 300 FEET RANGE
 CURRENT PROBE EXCITATION

5.4 RAW DATA FROM AMAX LEAD CO. OF MISSOURI BUICK MINE

The MF and HF data taken at the 064 ore pass location is given respectively in Figures 113 and 114.

The MF and HF data taken at the 049 ore pass location is given respectively in Figures 115 and 116.

The VHF and UHF data taken at the 064 ore pass location is given respectively in Figures 117 and 118.

FIGURE 113

ORIGINAL OSCILLOGRAPHS OF MF SWEPT-FREQUENCY
DATA AT 064 ORE PASS; TX AT NORTH MINE Y
AMAX LEAD CO. BUICK MINE

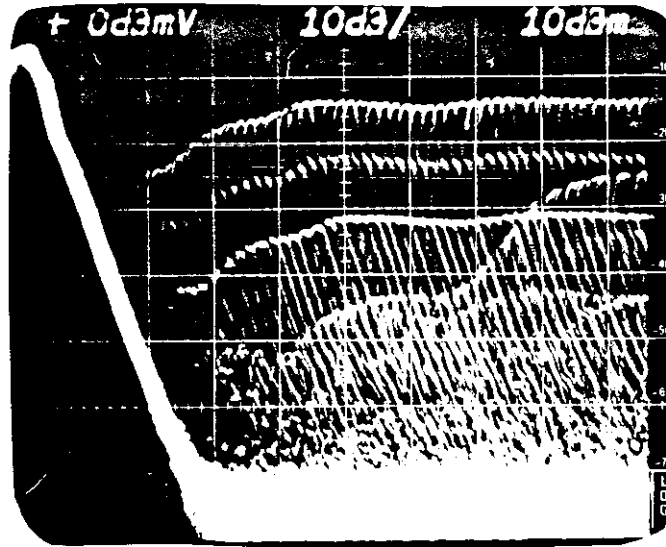

TX PROBE - RX PROBE

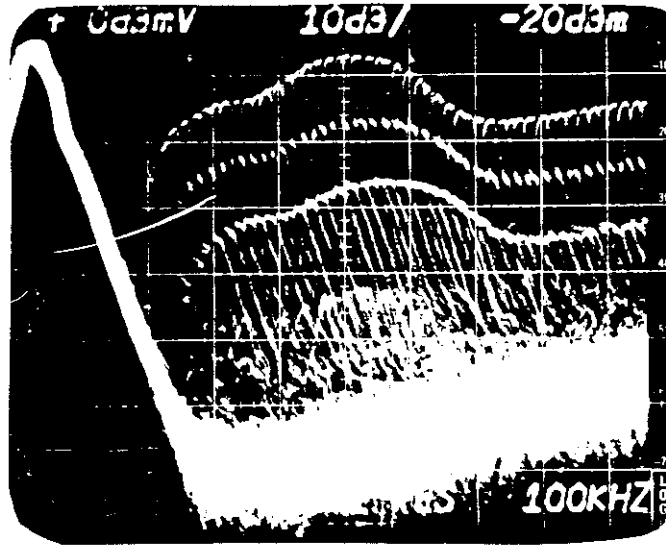

TX PROBE - RX ANTENNA

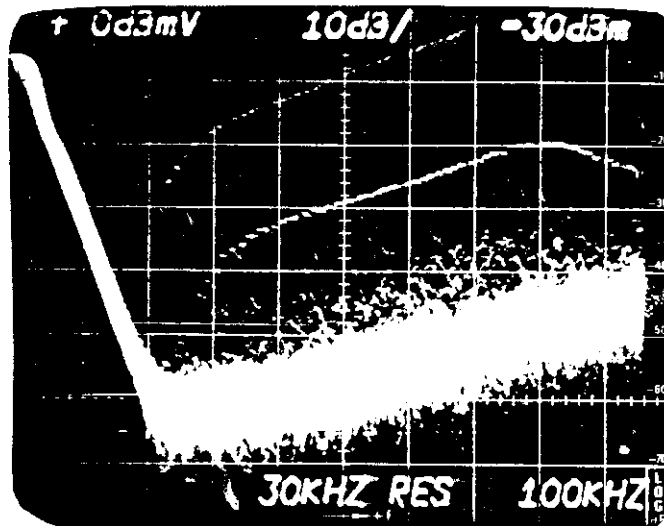

TX ANTENNA - RX ANTENNA

FIGURE 114

ORIGINAL OSCILLOGRAPHS OF HF SWEPT-FREQUENCY
DATA AT 064 ORE PASS; TX AT NORTH MINE Y
AMAX LEAD CO. BUICK MINE

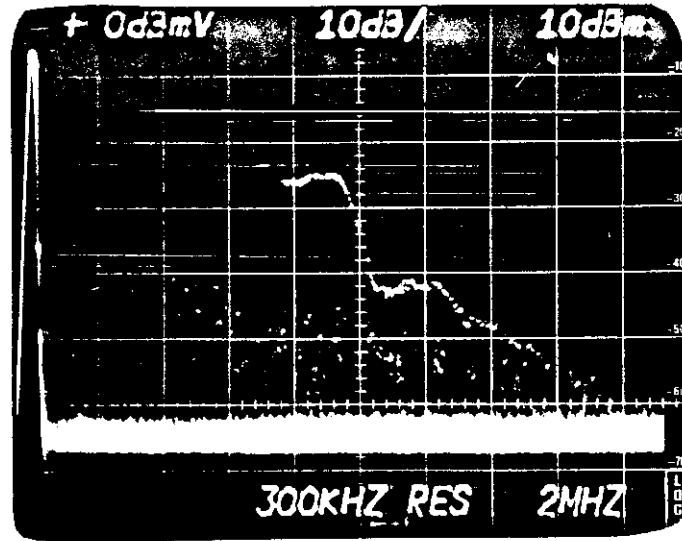

TX PROBE - RX PROBE

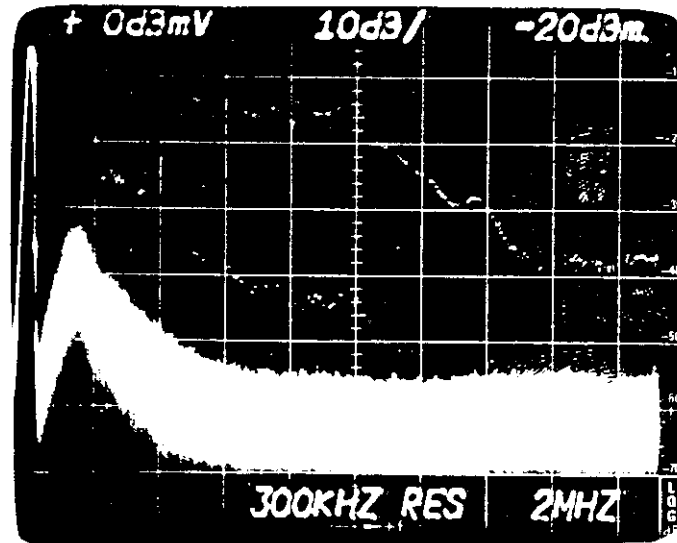

TX PROBE - RX ANTENNA

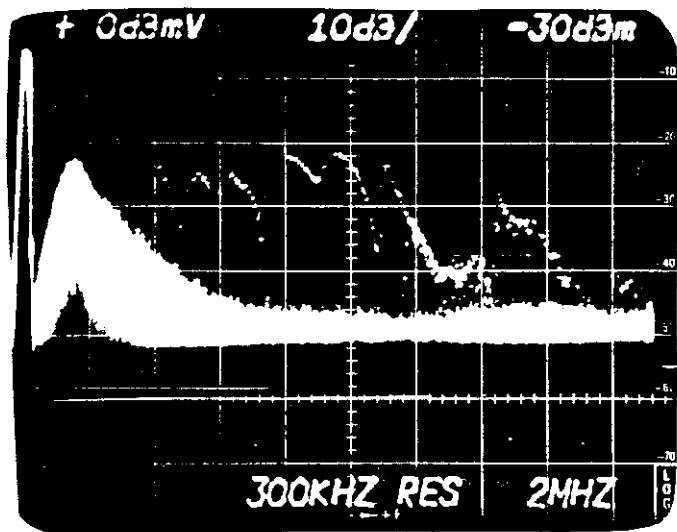

TX ANTENNA - RX ANTENNA

FIGURE 115

ORIGINAL OSCILLOGRAPHS OF MF SWEEP-FREQUENCY
DATA AT 049 ORE PASS; TX AT NORTH MINE Y
AMAX LEAD CO. BUICK MINE

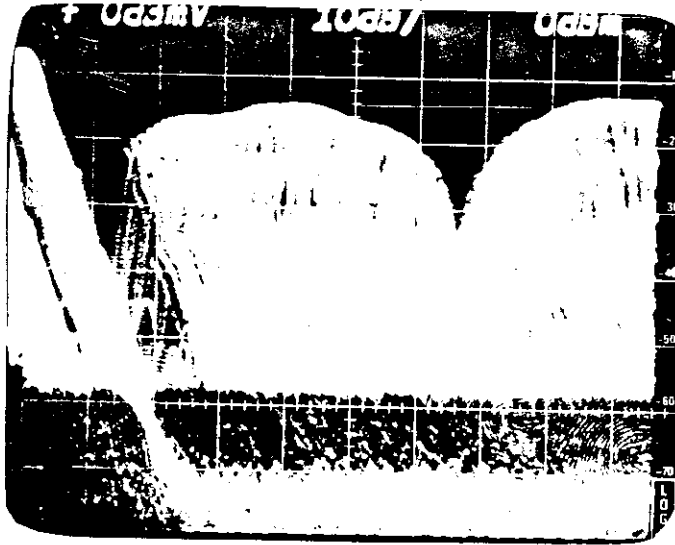

TX PROBE - RX PROBE



TX PROBE - RX ANTENNA

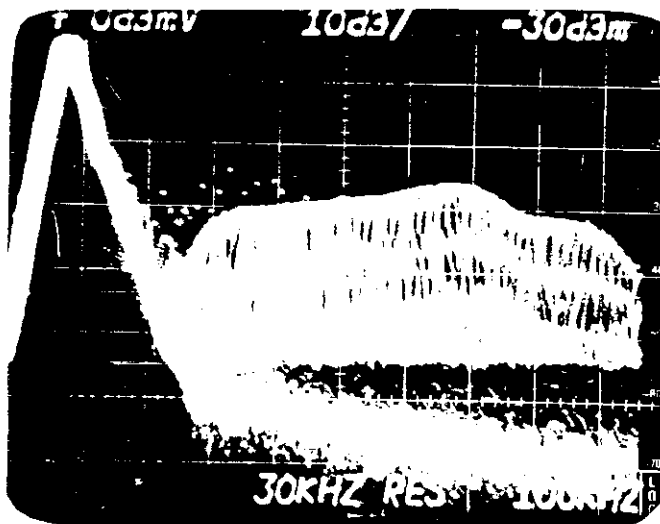

TX ANTENNA - RX ANTENNA

FIGURE 116

ORIGINAL OSCILLOGRAPHS OF HF SWEPT-FREQUENCY
DATA AT 049 ORE PASS; TX AT NORTH MINE Y
AMAX LEAD CO. BUICK MINE

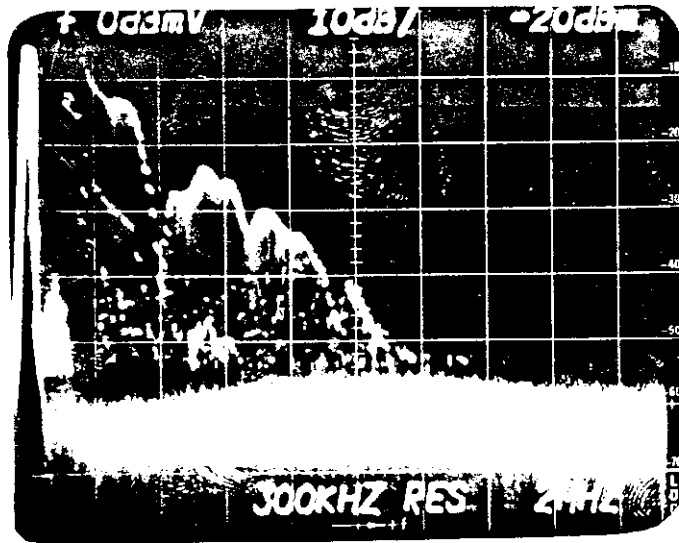

TX PROBE - RX PROBE

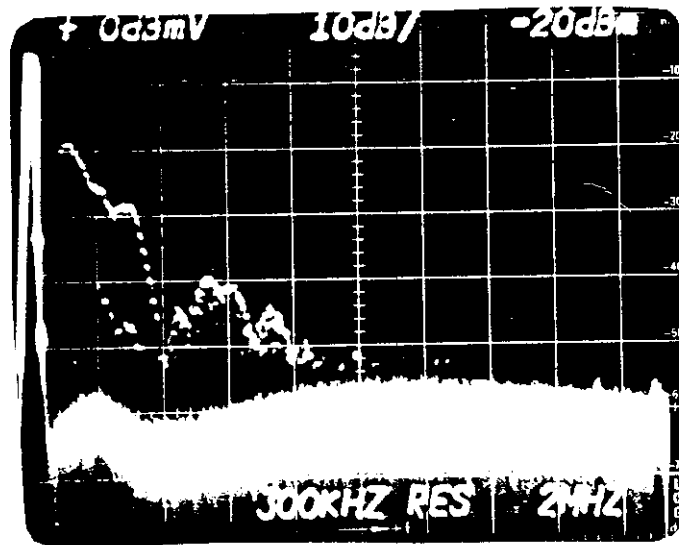

TX PROBE - RX ANTENNA

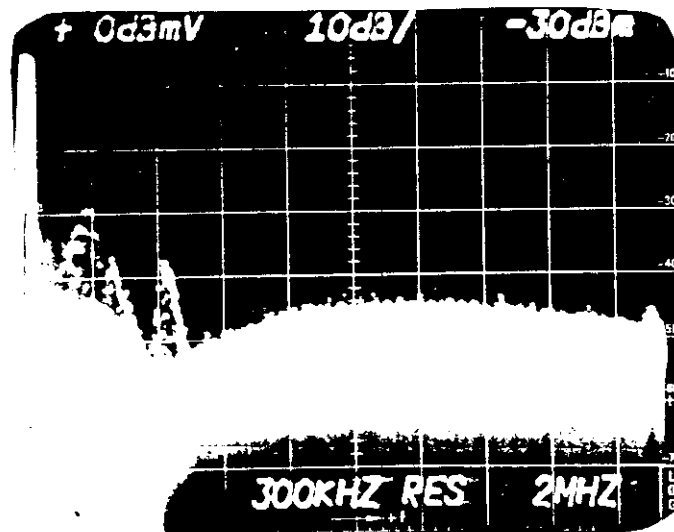

TX ANTENNA - RX ANTENNA

FIGURE 117

ORIGINAL OSCILLOGRAPHS OF VHF SWEPT-FREQUENCY
DATA TAKEN IN THE NORTH MINE TRACKED HAULAGE-
WAY AT THE 064 ORE PASS; TX LOCATED AT Y
MAX LEAD CO. BUICK MINE

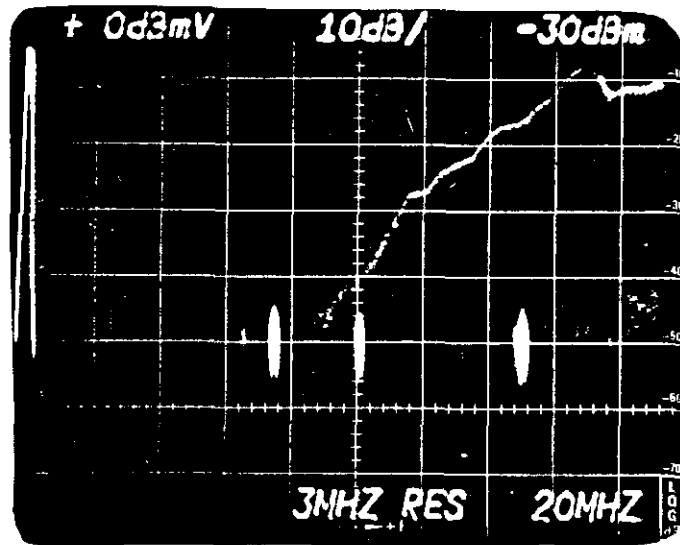

HORIZONTAL POLARIZATION

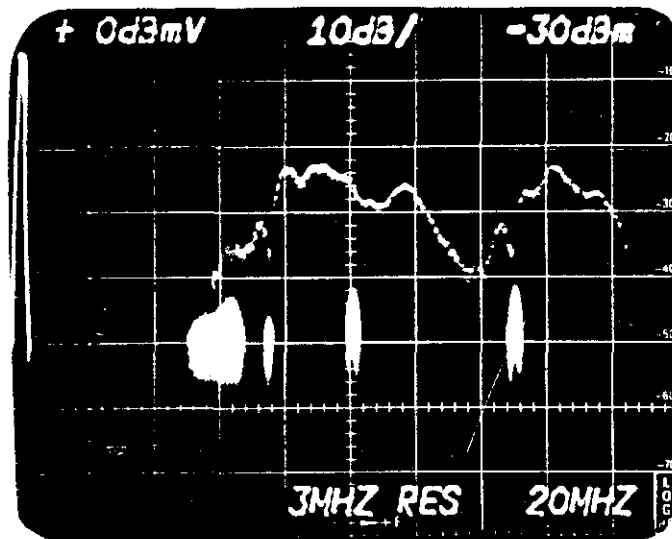

VERTICAL POLARIZATION

FIGURE 118

ORIGINAL OSCILLOGRAPHS OF UHF SWEEP-FREQUENCY
DATA TAKEN IN THE NORTH MINE TRACKED HAULAGE-
WAY AT THE 064 ORE PASS; TX LOCATED AT Y
MAX LEAD CO. BUICK TINE

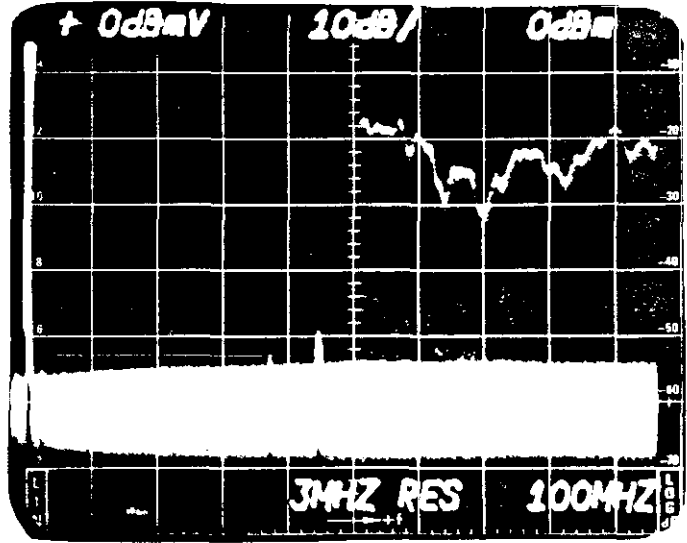
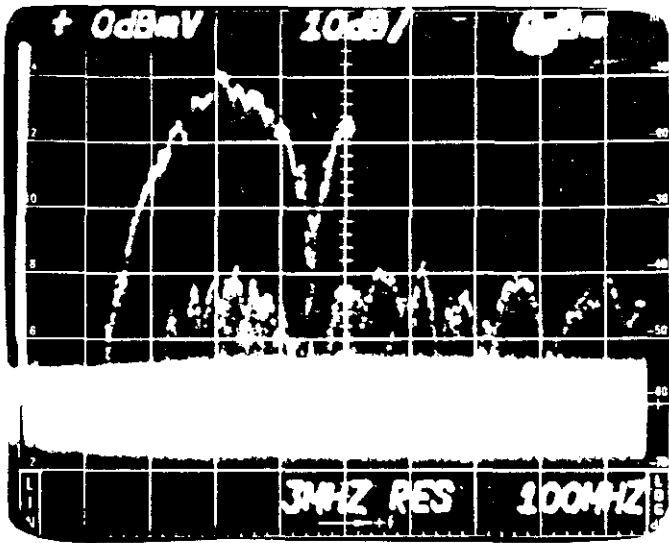

HORIZONTAL POLARIZATION

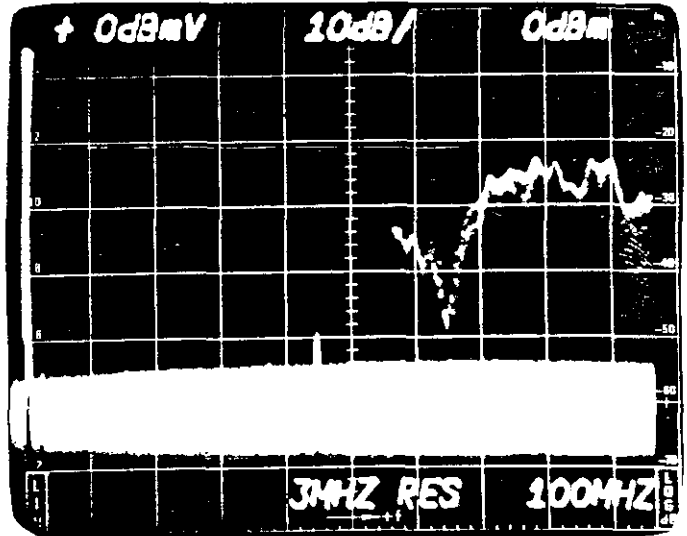
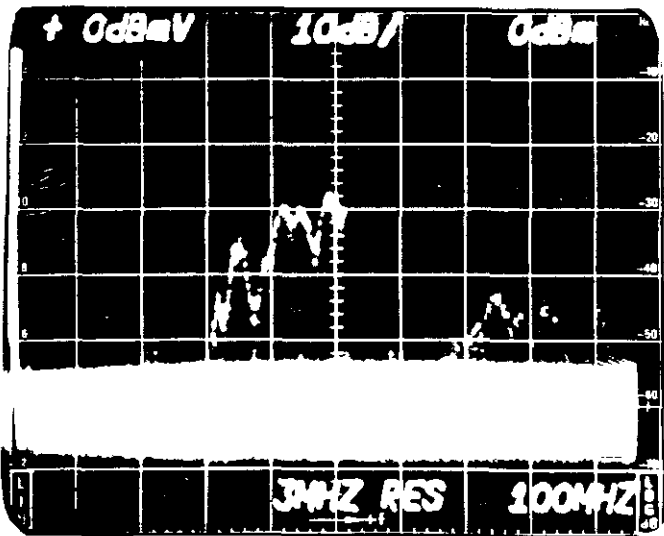

VERTICAL POLARIZATION

5.5 RAW DATA FROM MAGMA COPPER CO. SAN MANUEL MINE

The MF and HF data taken in the car-cleaner drift is given respectively in Figures 119 and 120.

The VHF and UHF data taken in the car-cleaner drift is given respectively in Figures 121 and 122.

The 520 KHz CW test oscillographs is given in Figures 123 through 130.
The 145 KHz CW test oscillographs is given in Figures 131 through 133.

FIGURE 119

ORIGINAL OSCILLOGRAPHS OF MF SWEEP-FREQUENCY
DATA TAKEN ON CAR-CLEANER TRACK DRIFT
MAGMA COPPER CO., SAN MANUEL MINE

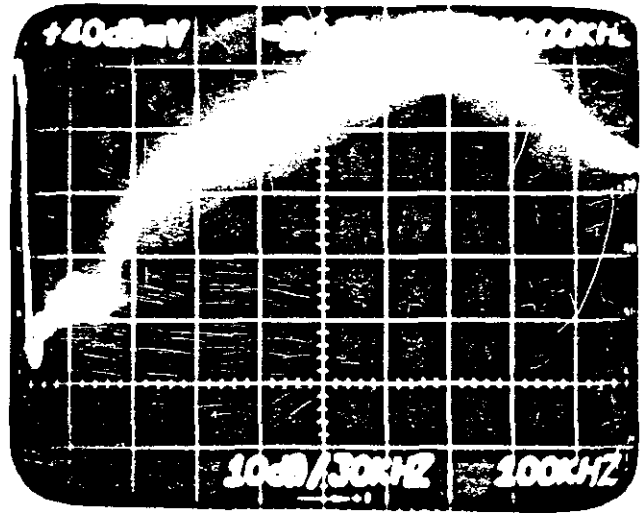

TX & RX ANTENNAS VMD, RX AT 1-FT, TX AT 1-FT

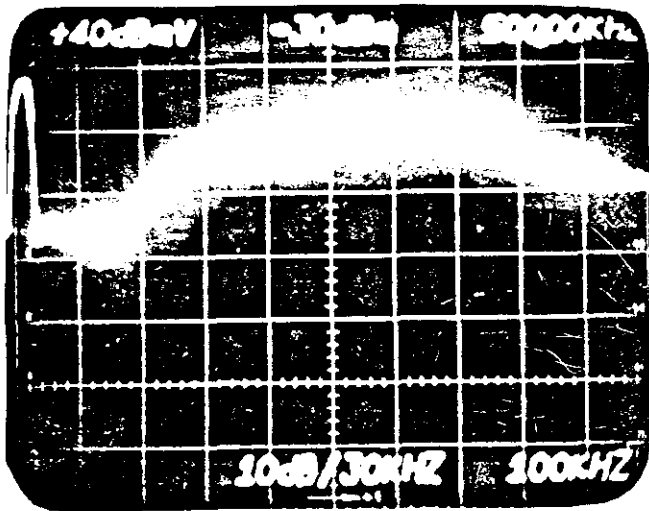

TX & RX ANTENNAS COPLANAR HMD 1.1 M ABOVE TRACK

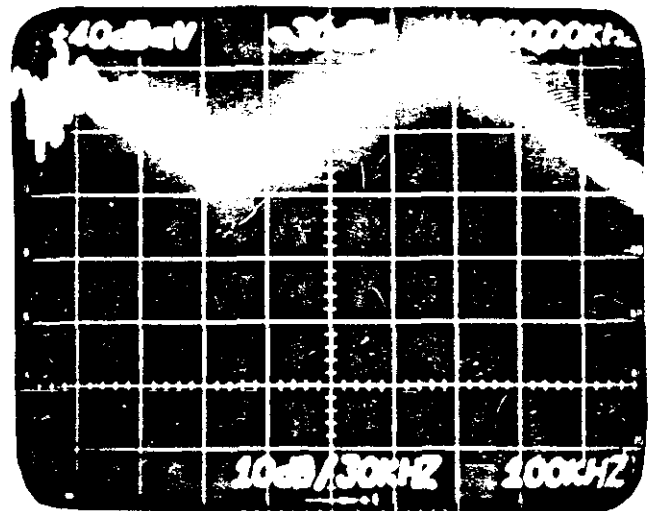

TX & RX ANTENNAS VMD, RX AT 4-FT, TX AT 1-FT

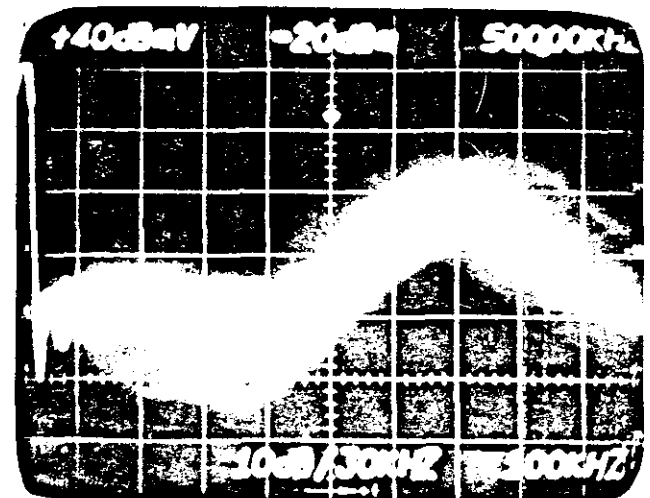

TX & RX ANTENNAS VMD, RX AT 8-FT, TX AT 1-FT

FIGURE 120

ORIGINAL OSCILLOGRAPH OF HF SWEPT-FREQUENCY
DATA TAKEN OF CAR-CLEANER TRACK DRIFT
MAGMA COPPER CO. SAN MANUEL MINE

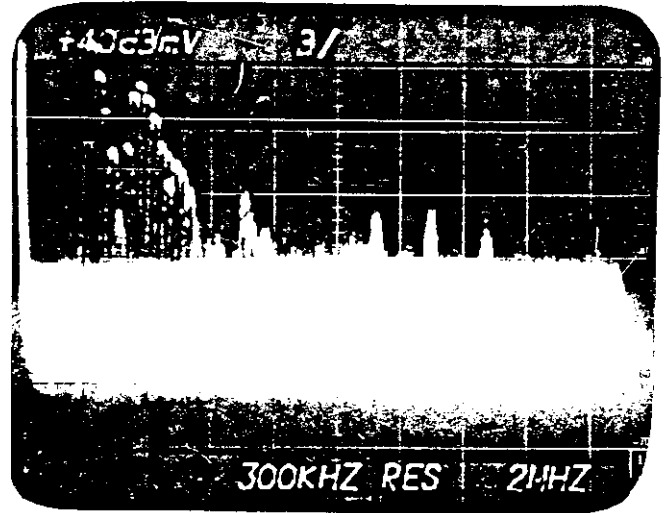

TX & RX ANTENNAS VMD, RX AT 1-FT, TX AT 1-FT

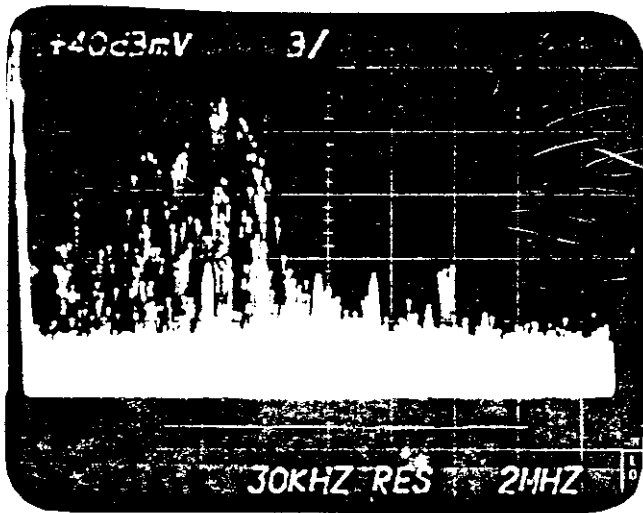

TX & RX ANTENNAS COPLANAR HMD 1.1 M ABOVE TRACK

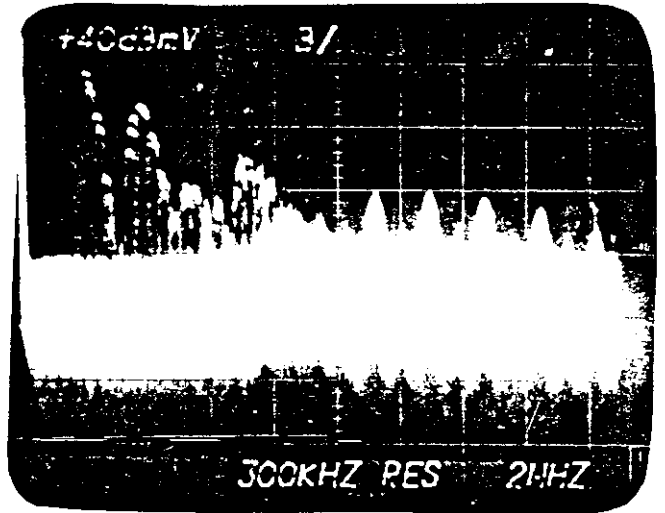

TX & RX ANTENNAS VMD, RX AT 4-FT, TX AT 1-FT

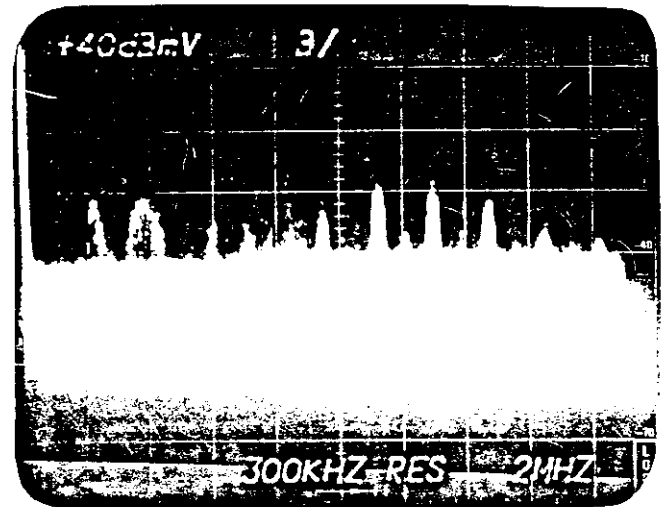

TX & RX ANTENNAS VMD, RX AT 8-FT, TX AT 1-FT

FIGURE 121

ORIGINAL OSCILLOGRAPHS OF VHF SWEPT-FREQUENCY
DATA TAKEN IN THE CAR-CLEANER TRACKED DRIFT
MAGMA COPPER CO. SAN MANUEL MINE

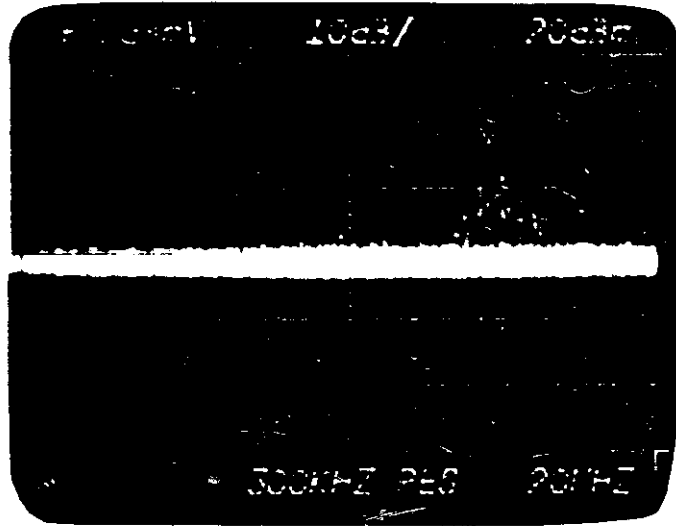

HORIZONTAL POLARIZATION

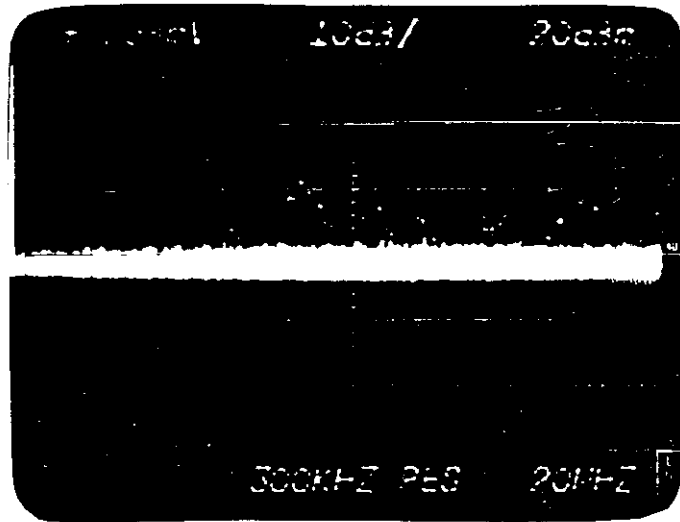

VERTICAL POLARIZATION

FIGURE 122

ORIGINAL OSCILLOGRAPHS OF UHF SWEPT-FREQUENCY
DATA TAKEN IN THE CAR-CLEANER TRACKED DRIFT
MAGMA COPPER CO., SAN MANUEL MINE

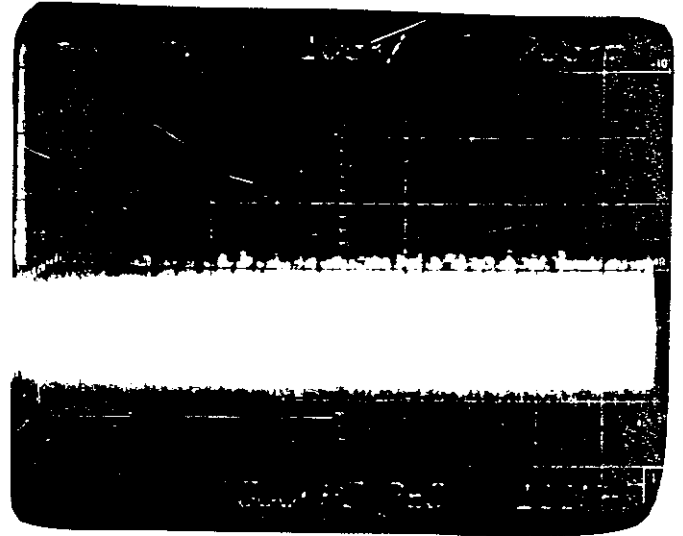
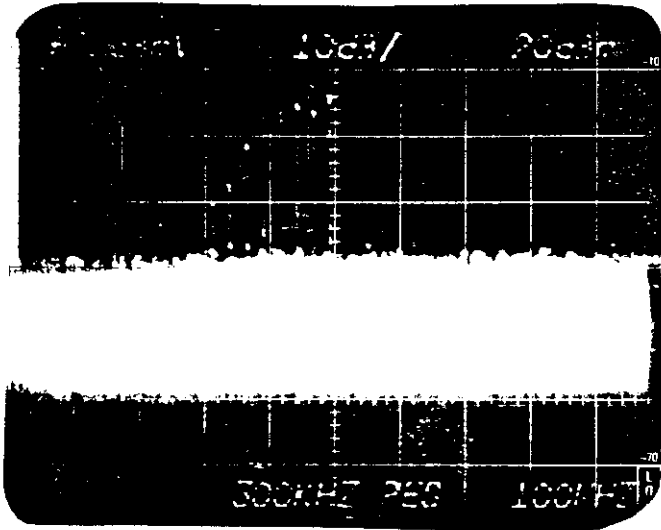

HORIZONTAL POLARIZATION

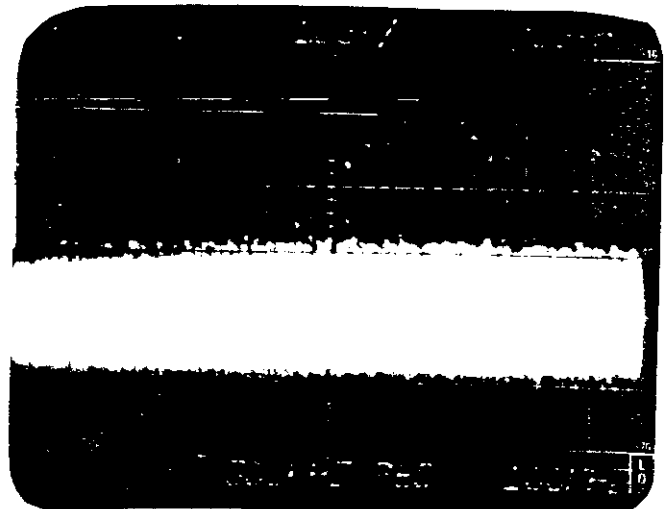
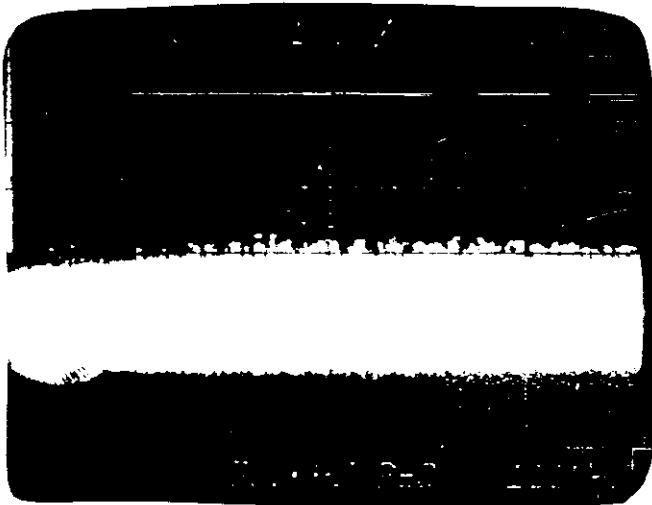

VERTICAL POLARIZATION

FIGURE 123

ORIGINAL OSCILLOGRAPHS FROM 520 KHZ CARRIER
PHONE TESTING, VEHICLE-BASE LOCATIONS A - C
MAGMA COPPER CO. SAN MANUEL MINE

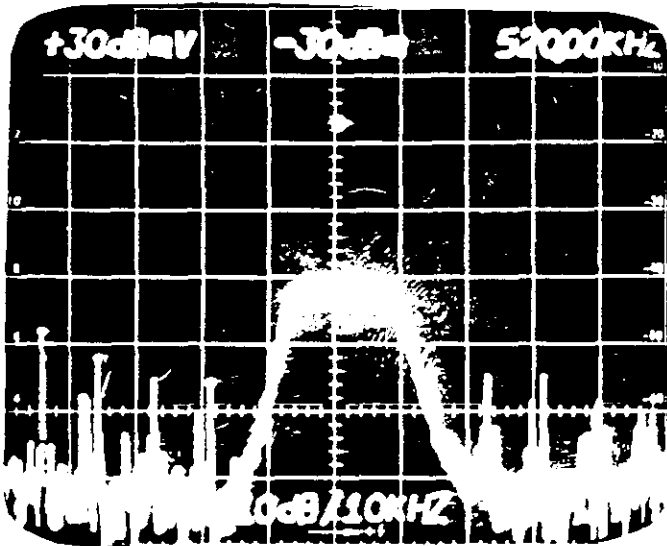

LOCATION A

XMIT FROM LOCO MACHINE SHOP, 20W IN VEHICLE
ANTENNA

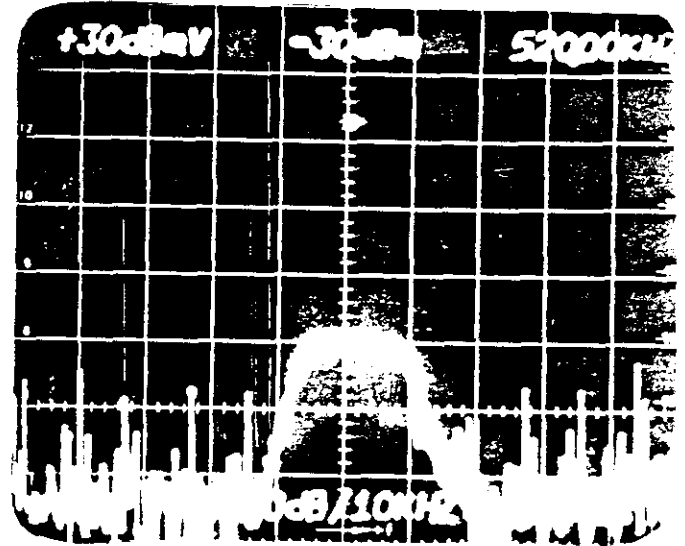

LOCATION C

C1, CAR-CLEANER TURNOUT; 3-DOG DEPARTURE
SAME LEVEL

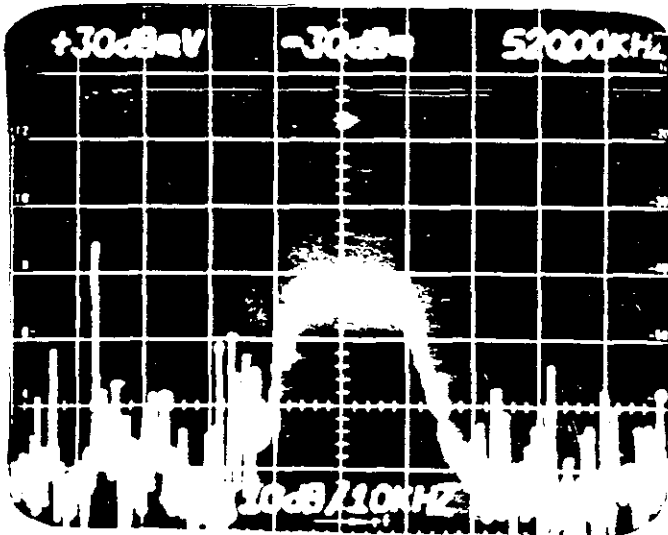

LOCATION B

FIRST TURNOUT

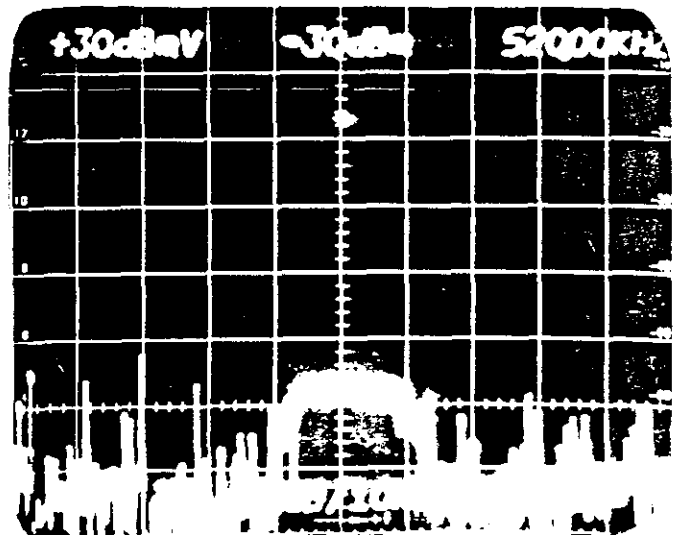

LOCATION C

C2, AFTER 3-DOG DEP; MOBILE CANNOT HEAR
BASE

NOTE: RECEIVE PREAMP NOT USED AT THESE LOCATIONS

FIGURE 124

ORIGINAL OSCILLOGRAPHS FROM 520 KHZ CARRIER
PHONE TESTING, VEHICLE-BASE, LOCATIONS D - G
MAGMA COPPER CO. SAN MANUEL MINE

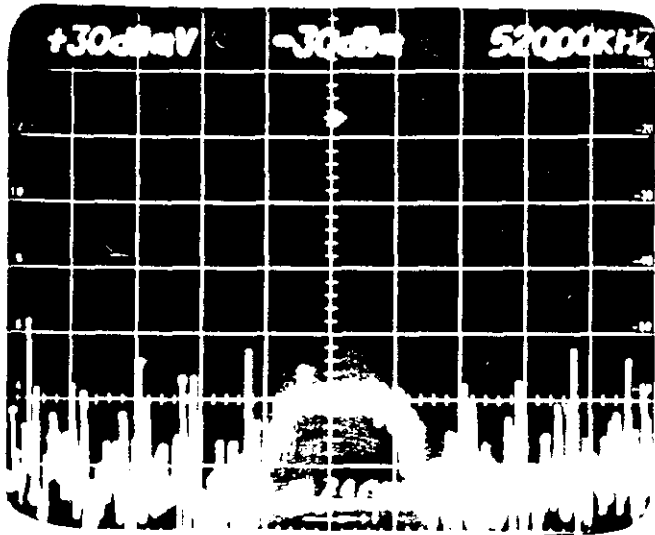

LOCATION D

ABOUT 500 FT ALONG SOUTH HAULAGE PAST
3-DOG DEPARTURE

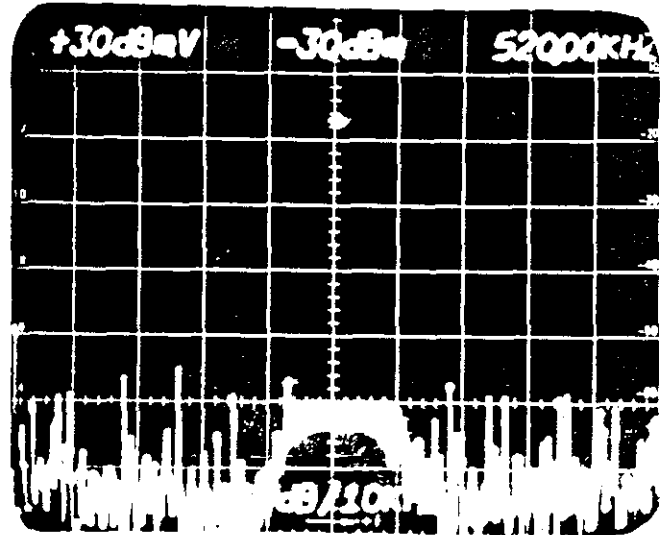

LOCATION F

MIDWAY BETWEEN 3-DOG DEP & 17 SOUTH

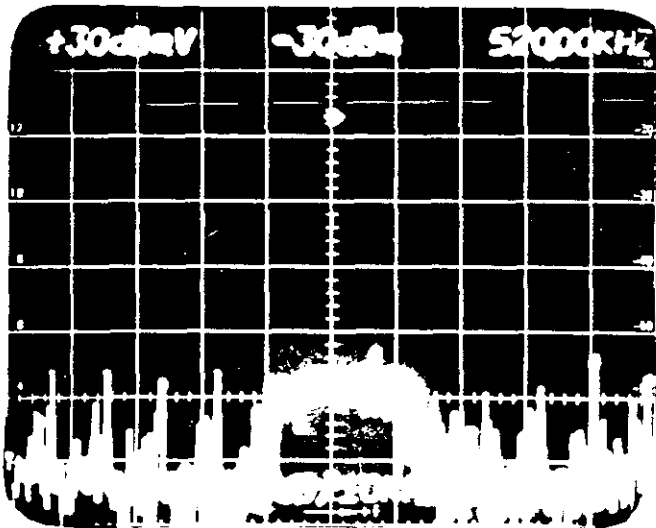

LOCATION E

ABOUT 1000 FT ALONG SOUTH HAULAGE PAST
3-DOG DEPARTURE

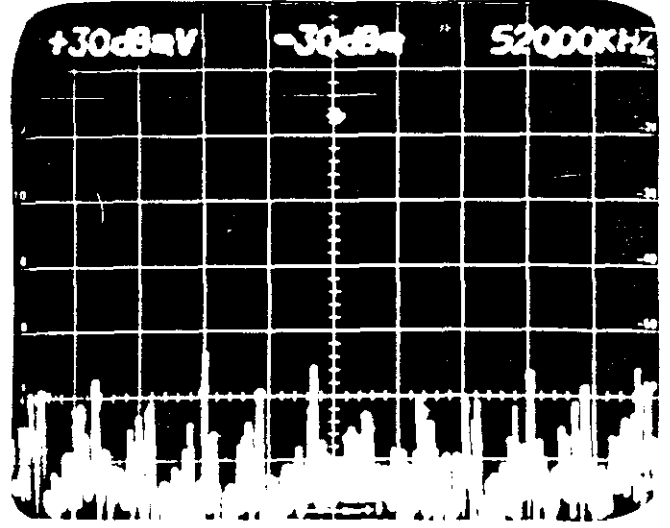

LOCATION G

G1, PANEL 17, MAIN CROSSCUT

NOTE: RECEIVE PREAMP NOT USED AT THESE LOCATIONS

FIGURE 125

ORIGINAL OSCILLOGRAPHS FROM 520 KHZ CARRIER
PHONE TESTING, VEHICLE-BASE, LOCATIONS G - J
MAGMA COPPER CO. SAN MANUEL MINE

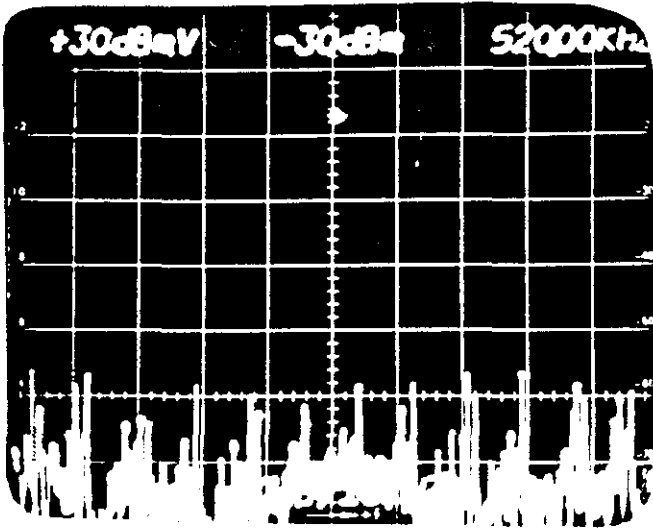

LOCATION G

G2, 17 SOUTH, NOISY

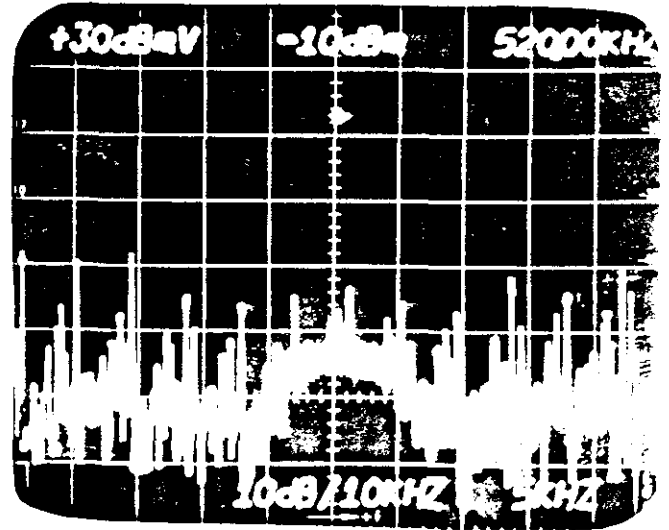

LOCATION I

PANEL 17

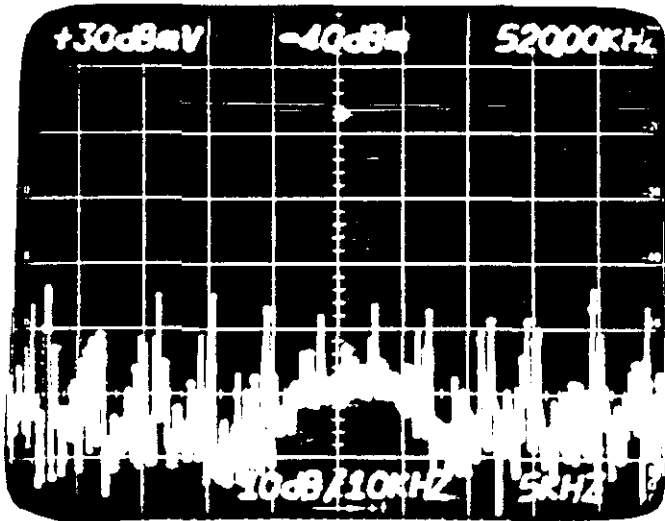

LOCATION H

PANEL 17, MAIN CROSSCUT

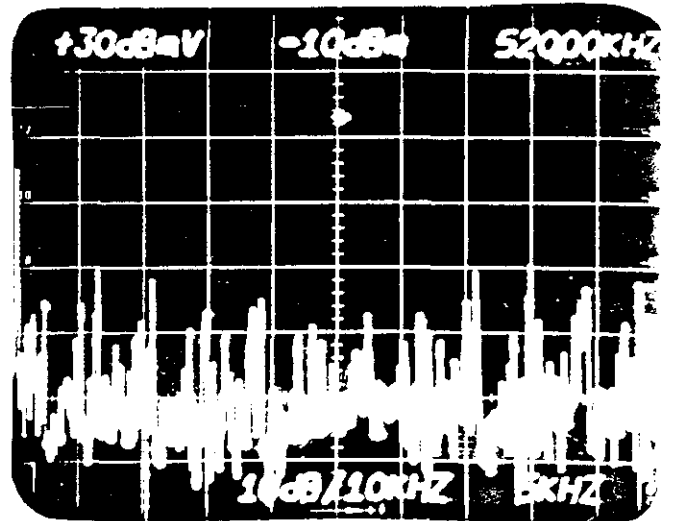

LOCATION J

PANEL 17 NORTH

NOTE: RECEIVE PREAMP NOT USED AT LOCATIONS G & H; ALL LOCATIONS THEREAFTER USED
THE PREAMP WITH 33 DB GAIN

FIGURE 126

ORIGINAL OSCILLOGRAPHS FROM 520 KHZ CARRIER
PHONE TESTING, VEHICLE-BASE, LOCATIONS K - M
MAGMA COPPER CO. SAN MANUEL MINE

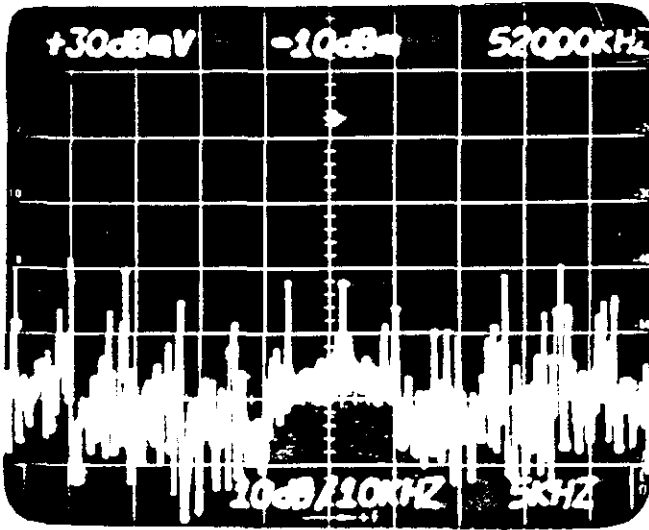

LOCATION K

K1, PANEL 17 MAIN

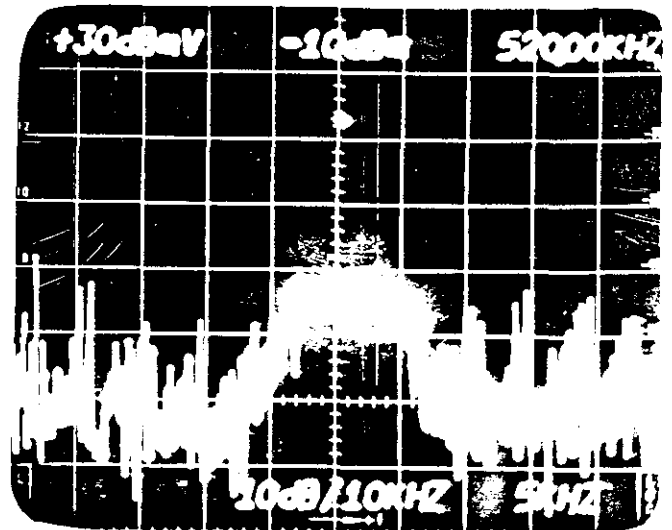

LOCATION L

TOWARD 20 CROSSOVER

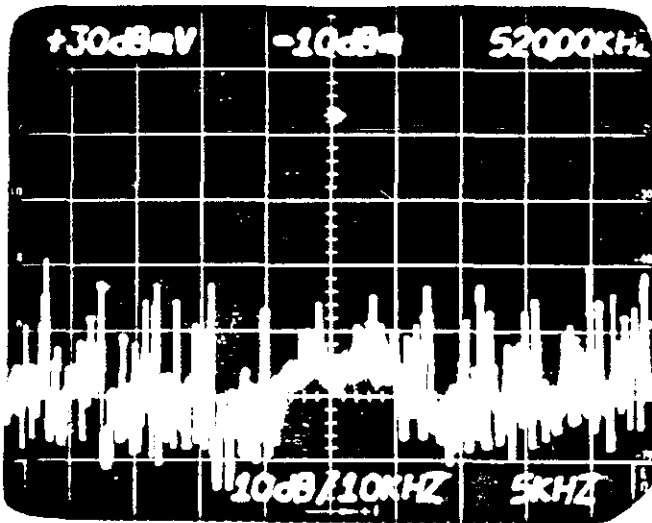

LOCATION K

K2, MAIN LINE 17 NORTH/2 HAULAGE

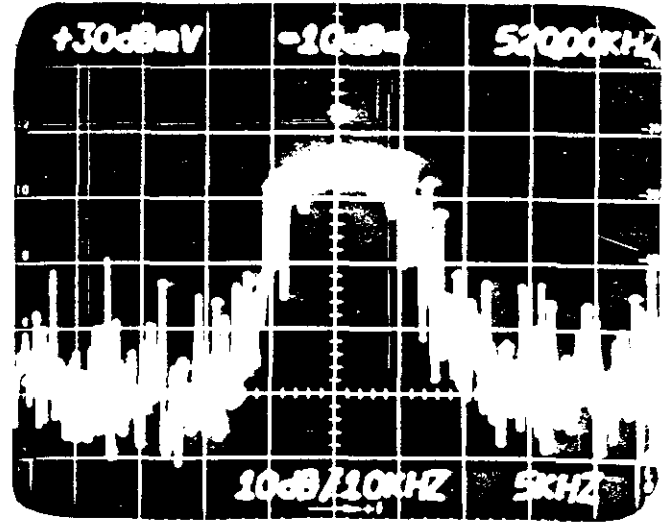

LOCATION M

NORTH HAULAGE-1, CHANGED ANTENNA LOCATION

FIGURE 127

ORIGINAL OSCILLOGRAPHS FROM 520 KHZ CARRIER
PHONE TESTING, VEHICLE-BASE, LOCATIONS N - Q
MAGMA COPPER CO. SAN MANUEL MINE

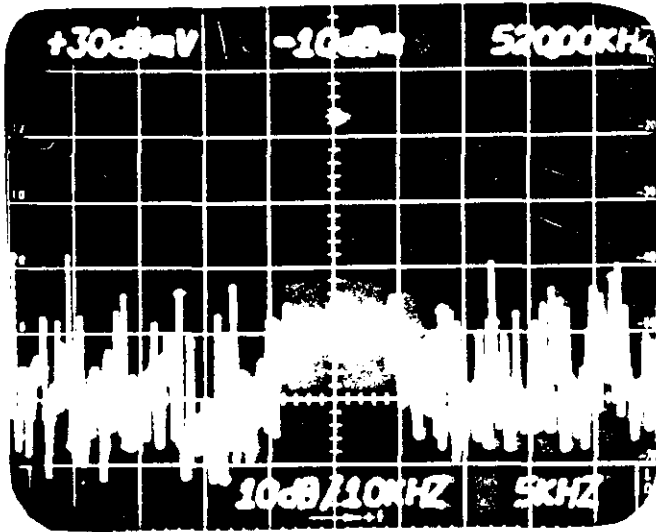

LOCATION N

JUST AFTER 20, SEVERAL HUNDRED FEET

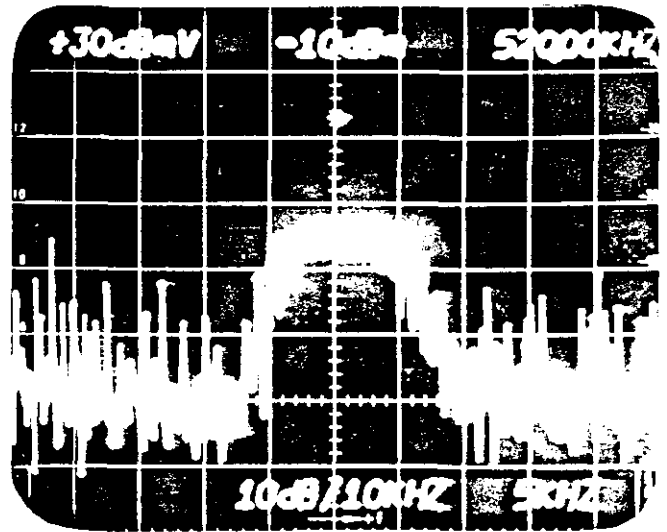

LOCATION P

100 FT PAST 30 CROSSOVER

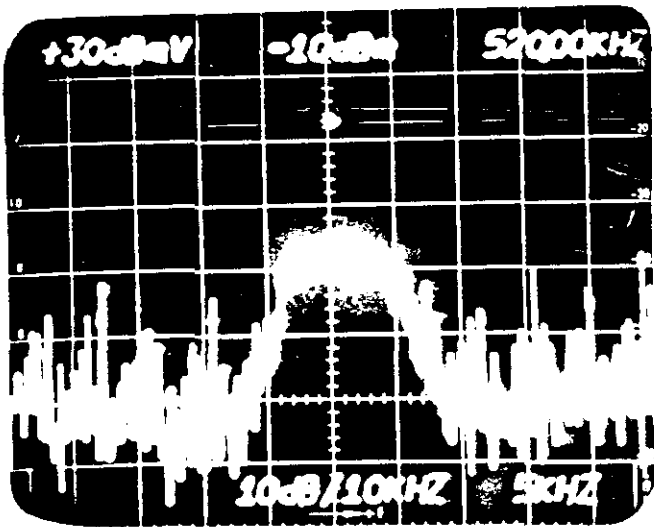

LOCATION Q

OLD DISPATCH SHACK

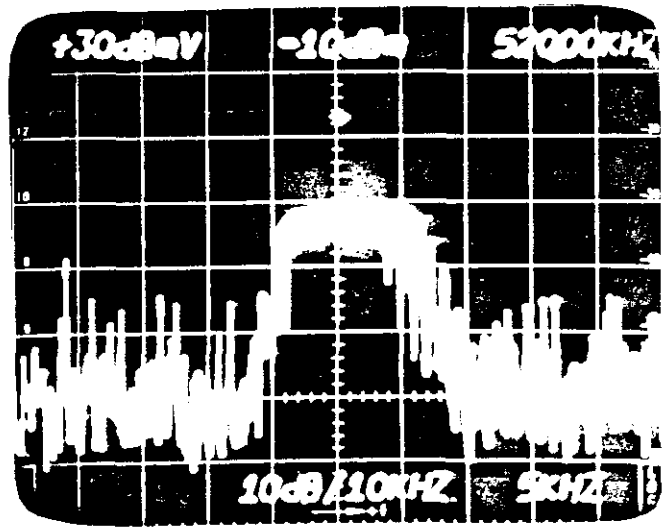

LOCATION R

FIGURE 128

ORIGINAL OSCILLOGRAPHS FROM 520 KHZ CARRIER
PHONE TESTING, VEHICLE-BASE, LOCATIONS R - S
MAGMA COPPER CO. SAN MANUEL MINE

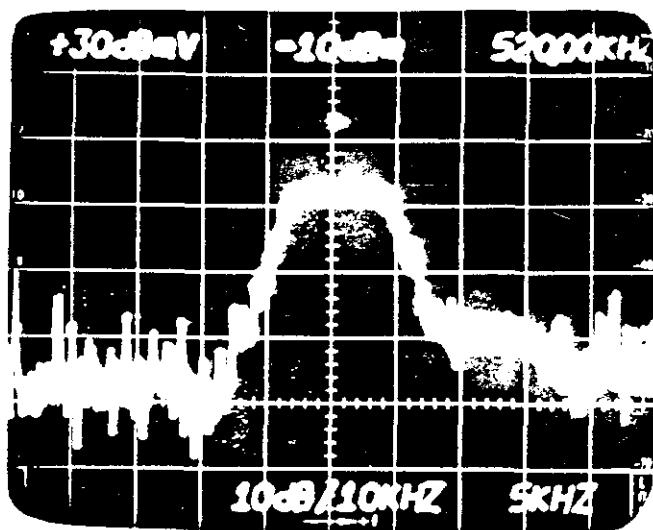

LOCATION R

R1, 5-SHAFT TURNOUT, PORTABLE (1-2 FT FROM WIRE)

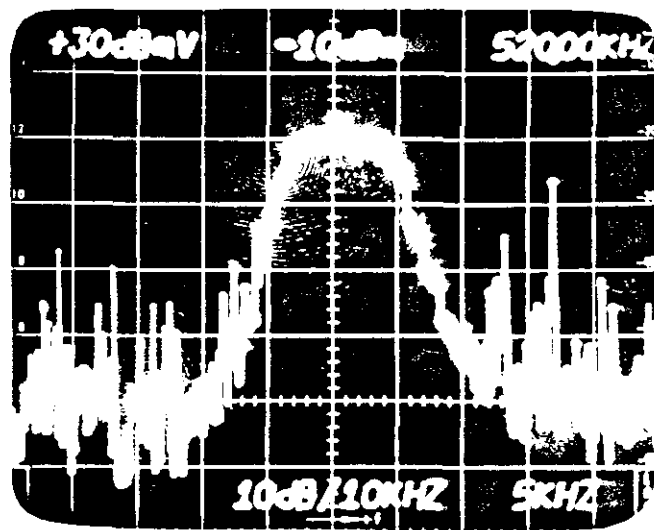

LOCATION S

S1, AIR DOORS, PORTABLE (1-2 FT FROM WIRE)

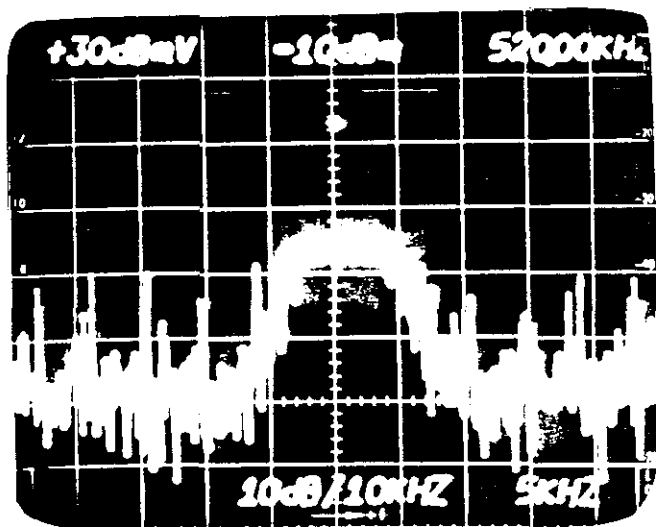

LOCATION R

R2, 5-SHAFT TURNOUT, VEHICLE

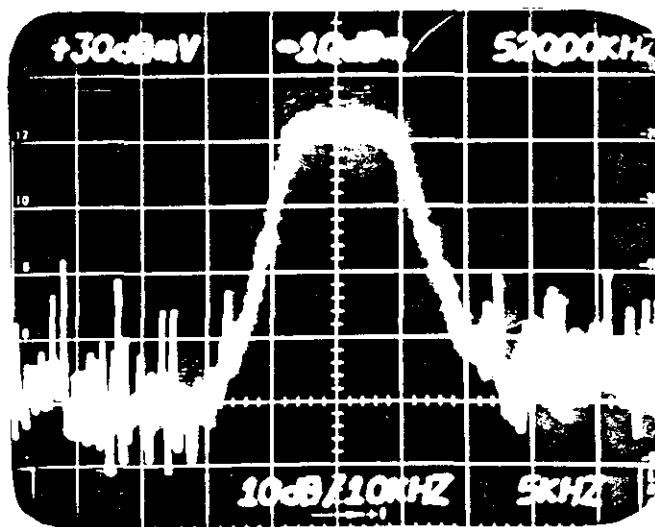

LOCATION S

S2, AIR DOORS, VEHICULAR

FIGURE 129

ORIGINAL OSCILLOGRAPHS FROM 520 KHZ CARRIER
PHONE TESTING, VEHICLE-BASE, LOCATIONS T - V
MAGMA COPPER CO. SAN MANUEL MINE

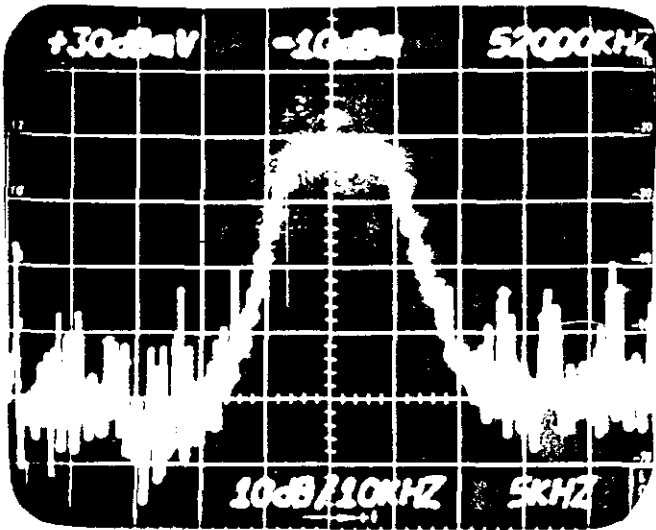

LOCATION T
BETWEEN AIR DOORS

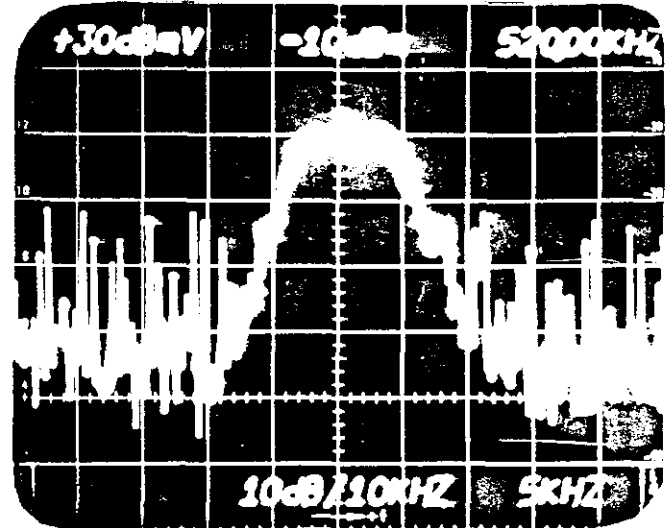

LOCATION V
V1, 2ND SET OF AIR DOORS, PORTABLE (1-2 FT, WIRE)

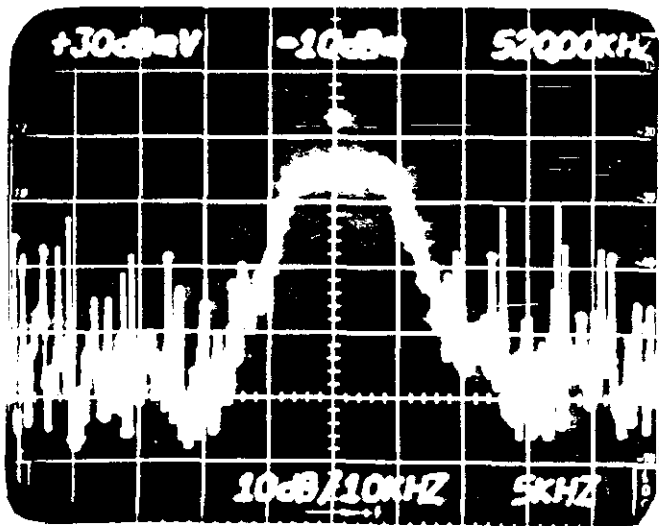

LOCATION U
AFTER AIR DOORS

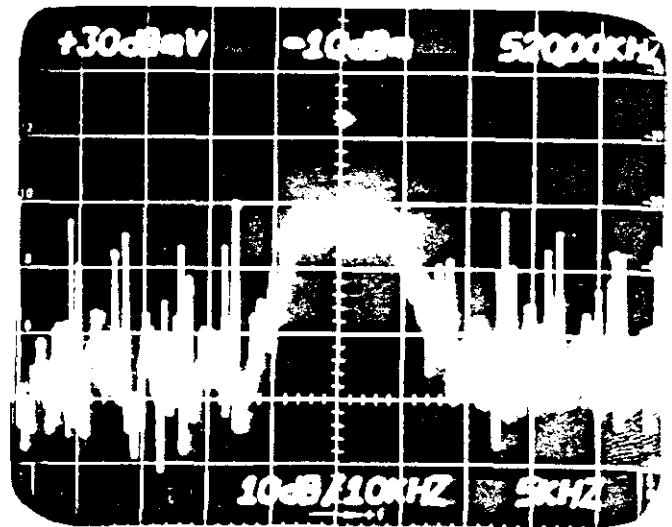

LOCATION V
V2, 2ND SET OF AIR DOORS, VEHICULAR

FIGURE 130

ORIGINAL OSCILLOGRAPHS FROM 520 KHZ CARRIER
PHONE TESTING, VEHICLE-BASE , LOCATIONS W - X
MAGMA COPPER CO. SAN MANUEL MINE

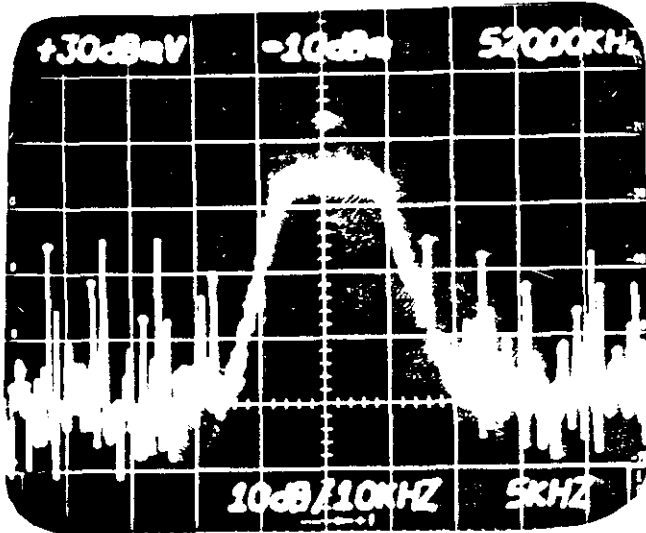

LOCATION W

W1, PORTABLE, 3-CHARLIE DEPARTURE, VERT LOOP

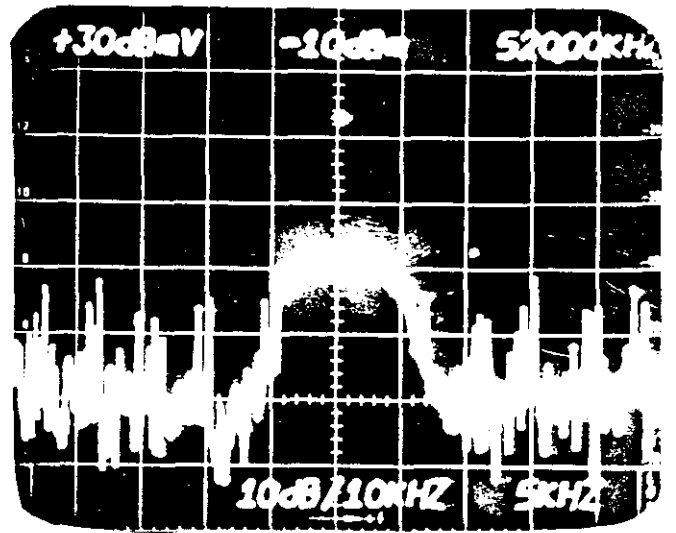

LOCATION W

W3, 3-CHARLIE DEPARTURE, VEHICULAR

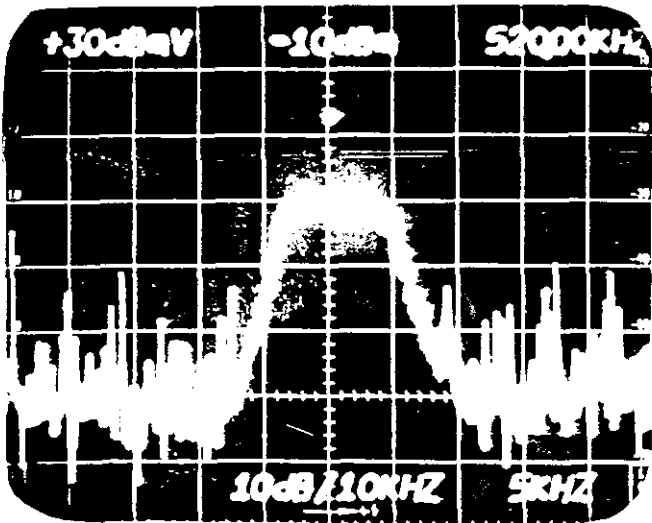

LOCATION W

W2, 3-CHARLIE DEPARTURE, PORTABLE (1-2 FT, WIRE)
HORIZONTAL LOOP

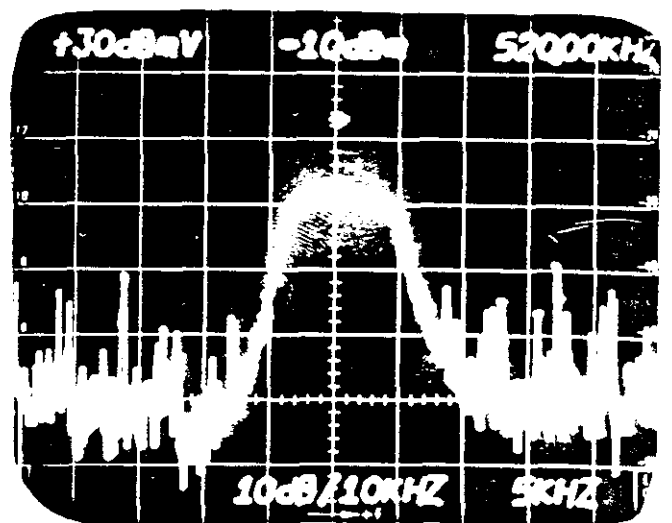

LOCATION X

PORTABLE, OUTSIDE LOCO SHOP, 1-2 FT FROM W1

FIGURE 131

ORIGINAL OSCILLOGRAPHS FROM 145 KHZ CARRIER
PHONE TESTING, BASE-VEHICLE, LOCATIONS G - K
MAGMA COPPER CO. SAN MANUEL MINE

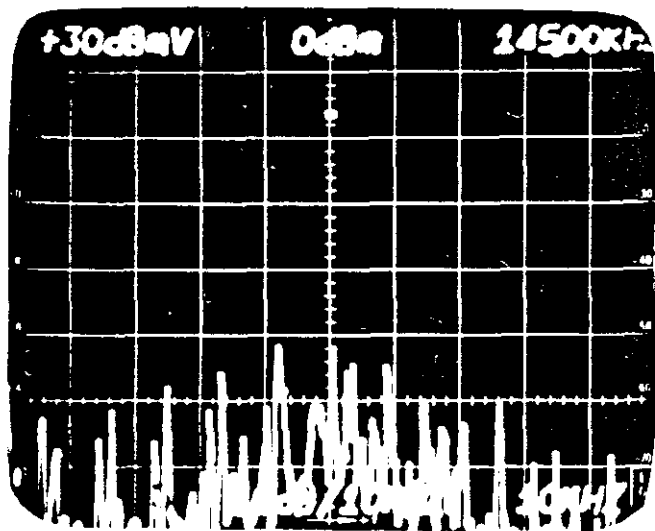

LOCATION G

G1, NOISE, 17 SOUTH, 2-METERS FROM WIRE

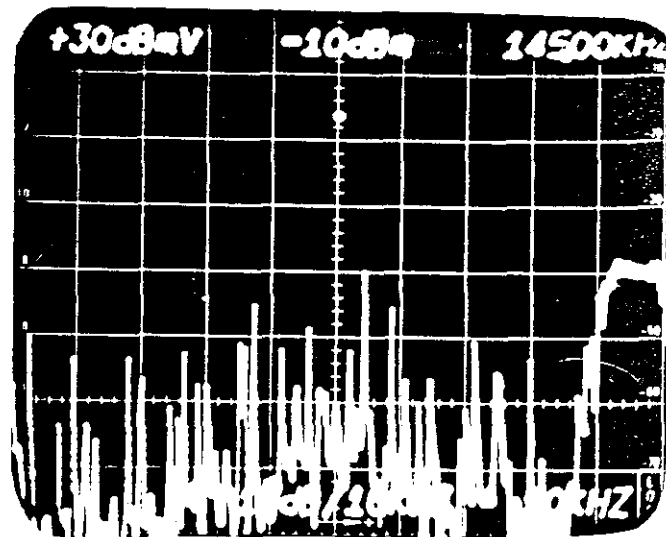

LOCATION K

K1, NOISE PLUS 190 KHZ, 17 SOUTH END

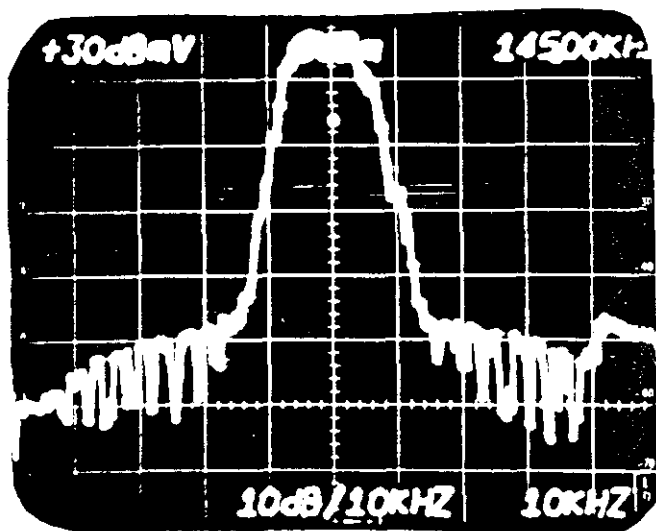

LOCATION G

G2, 17 SOUTH

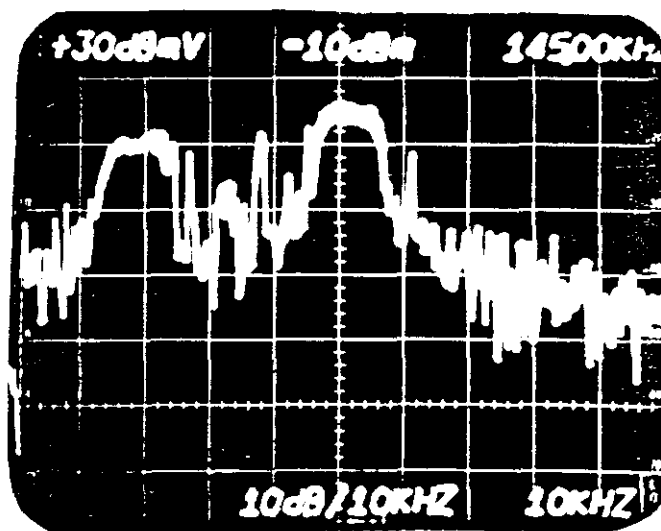

LOCATION K

K2, AFTER 17-NORTH SWITCH

FIGURE 132

ORIGINAL OSCILLOGRAPHS FROM 145 KHZ CARRIER
PHONE TESTING, BASE-VEHICLE, LOCATIONS M - Q
MAGMA COPPER CO. SAN MANUEL MINE

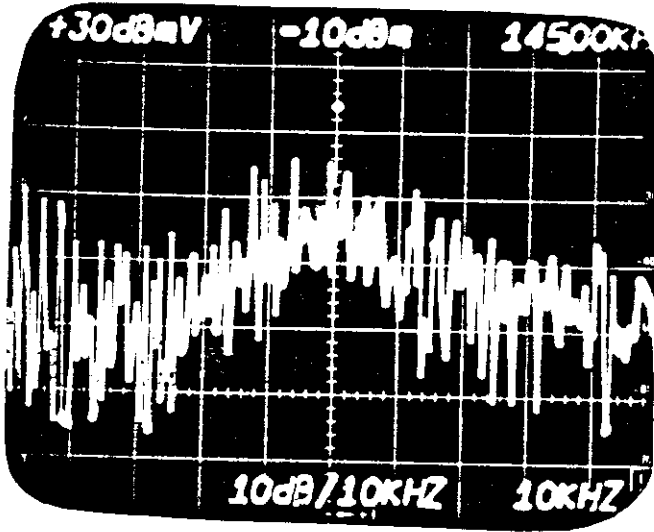

LOCATION M

M1, NOISE, NORTH HAULAGE-1

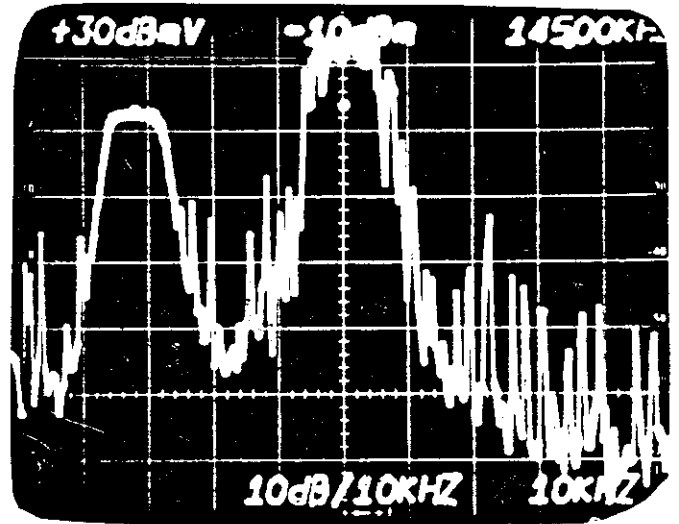

LOCATION O

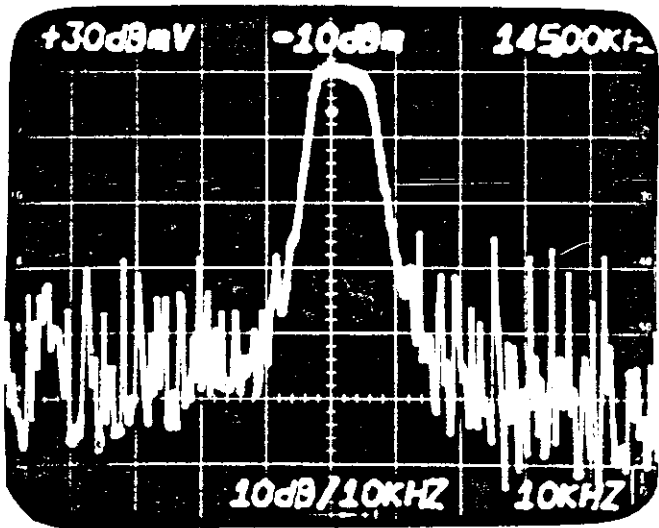

LOCATION M

M2, NORTH HAULAGE-1

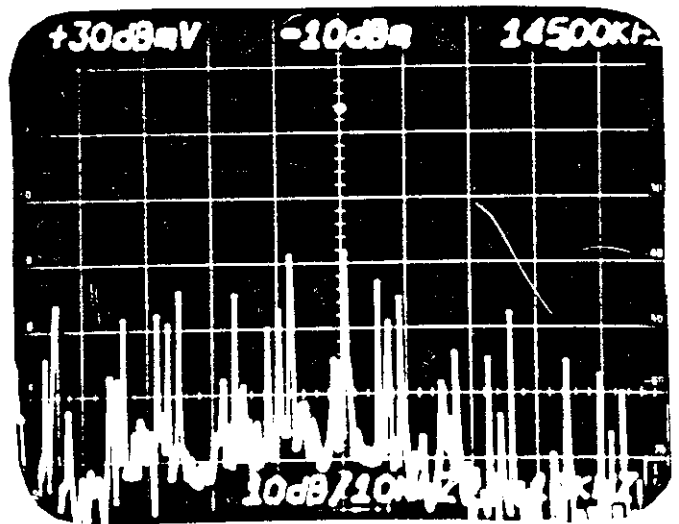

LOCATION Q

Q1, NOISE, NEAR 5-SHAFT TURNOUT

FIGURE 133
ORIGINAL OSCILLOGRAPHS FROM 145 KHZ CARRIER
PHONE TESTING, BASE-VEHICLE, LOCATIONS Q - X
MAGMA COPPER CO. SAN MANUEL MINE

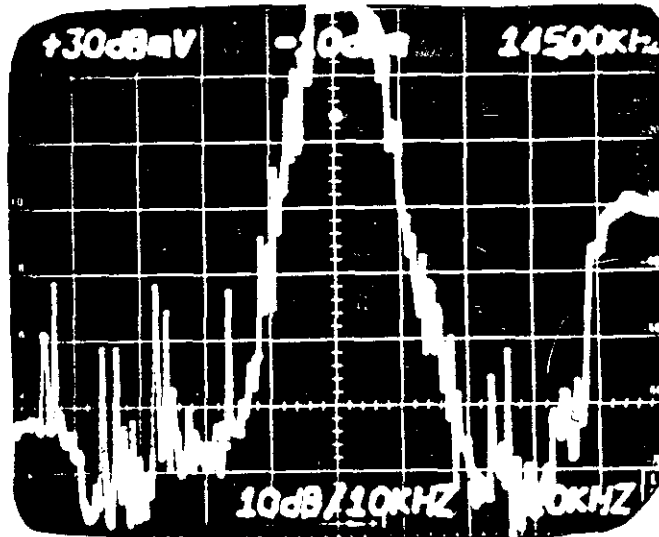

LOCATION Q

Q2, NEAR 5-SHAFT TURNOUT

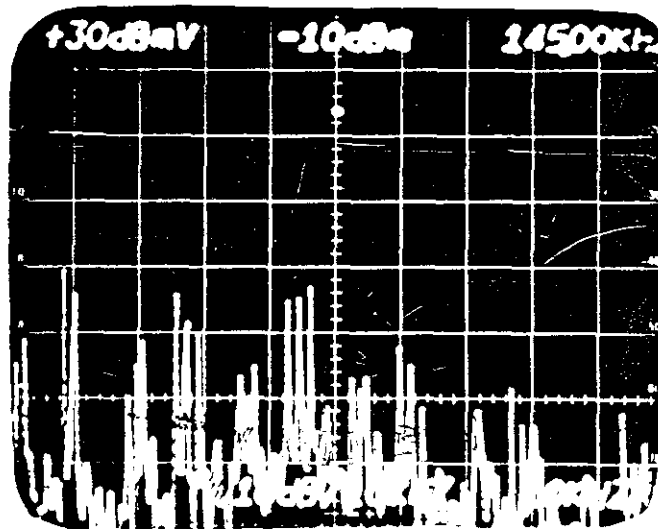

LOCATION X

OUTSIDE LOCO SHOP

5.6 RAW DATA FROM HECLA MINING CO. CON-SIL MINE

The MF data for horizontal magnetic dipole (HMD) and current-probe excitations is given in Figure 134. Similar data for the vertical magnetic dipole (VMD) antenna orientations is given in Figure 135.

The HF data for several antenna orientations is given in Figures 136, 137 and 138.

The VHF data for two receiving test locations is given in Figures 139 and 140 .

The UHF data for two receiving test locations is given in Figures 141 and 142.

FIGURE 134

ORIGINAL OSCILLOGRAPHS OF MF SWEEP-FREQUENCY
DATA TAKEN ALONG 3000-LEVEL NORTH CROSSCUT
HMD & PROBE CONFIGURATIONS

HECLA CON-SIL MINE

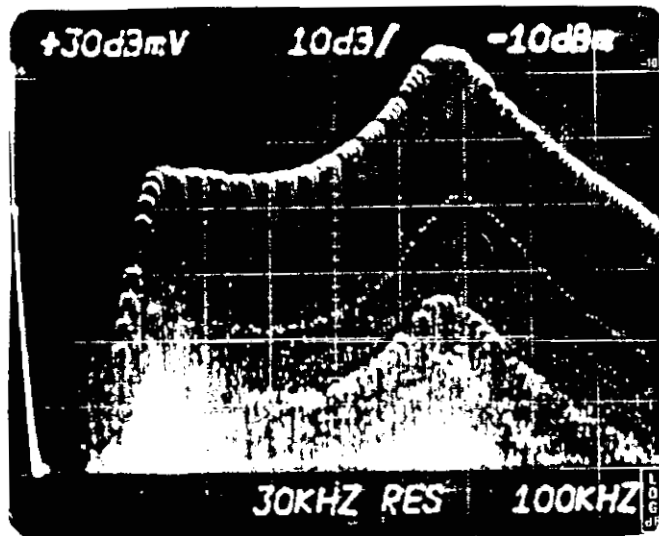

TX & RX ANTENNAS COPLANAR HMD; ANTENNAS AT
DRIFT CENTER (MIDDLE)

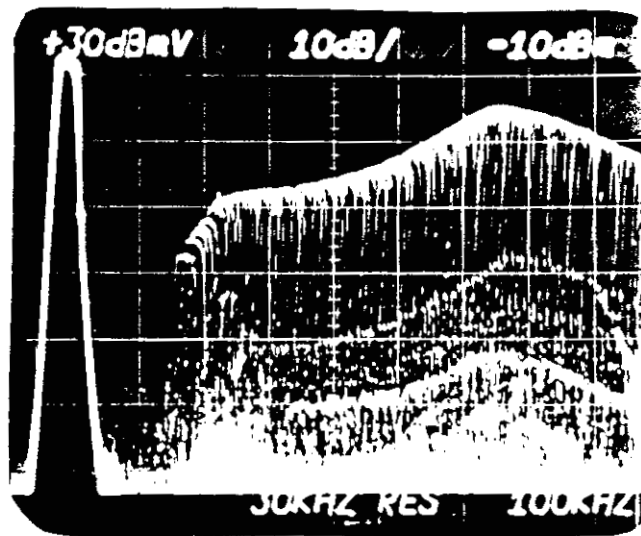

TX & RX COPLANAR HMD; ANTENNAS 1-FOOT AB
TRACK (BOTTOM)

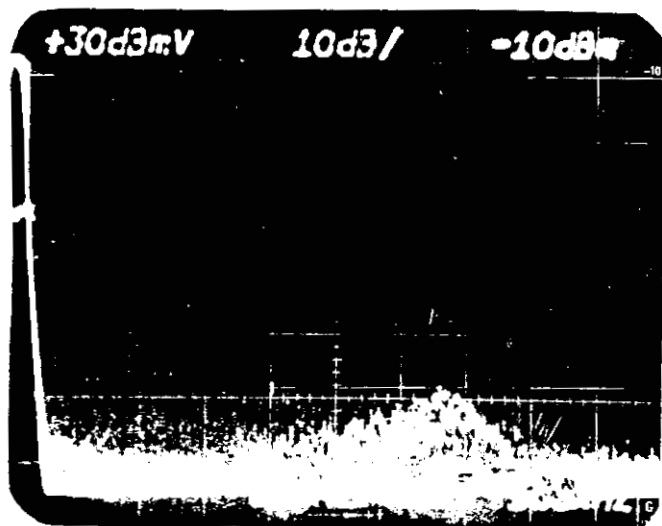

TX & RX ANTENNAS BROADSIDE HMD; ANTENNAS AT
DRIFT CENTER

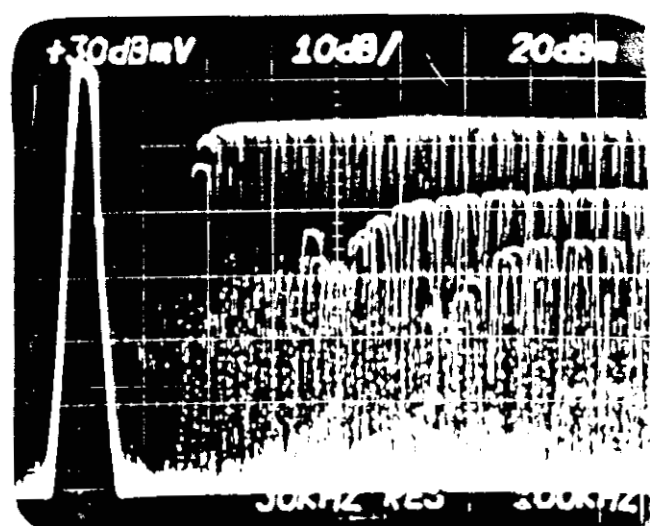

TX & RX CURRENT PROBES

FIGURE 135

ORIGINAL OSCILLOGRAPHS OF MF SWEEP-FREQUENCY
DATA ALONG 3000-LEVEL NORTH CROSSCUT-VMD
CONFIGURATIONS - HECLA CON-SIL MINE

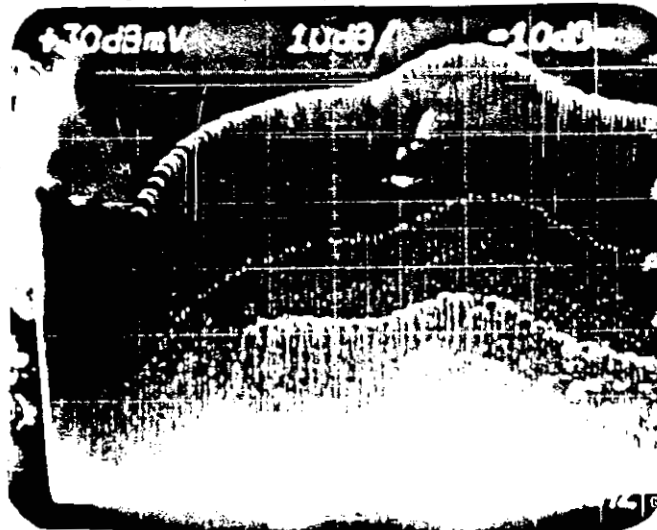

TX & RX ANTENNAS VMD NEAR DRIFT BACK
HORIZONTAL WITH WIRING BUNDLE (TOP)

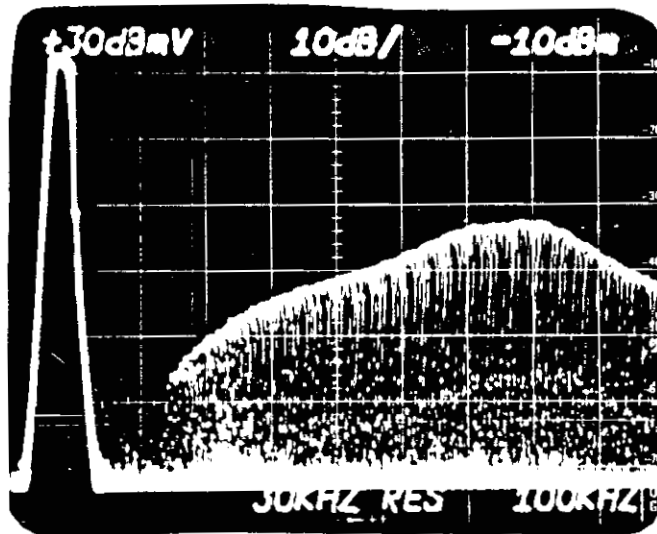

TX & RX ANTENNAS VMD AT DRIFT CENTER (MIDDLE)

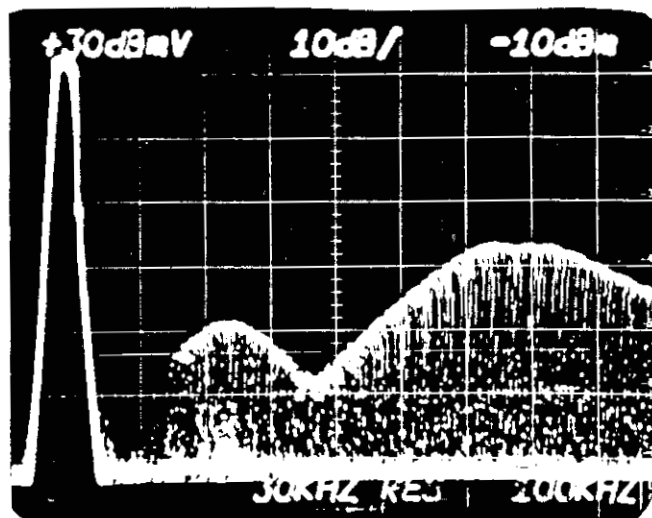

TX & RX ANTENNAS VMD 1-FOOT ABOVE TRACK (BOTTOM)

FIGURE 136

ORIGINAL OSCILLOGRAPHS OF HF SWEPT-FREQUENCY DATA ALONG 3000-LEVEL NORTH CROSSCUT-HMD AND PROBE CONFIGURATIONS W/O FREQUENCY INDEX REFERENCE - HECLA CON-SIL MINE

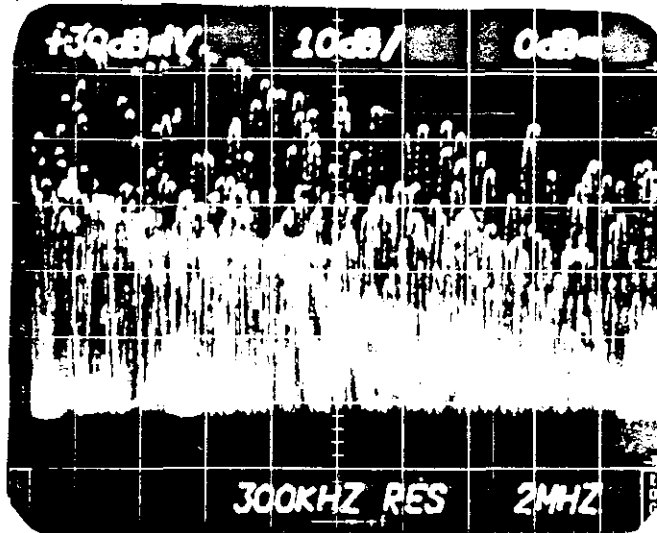

TX & RX CURRENT PROBES

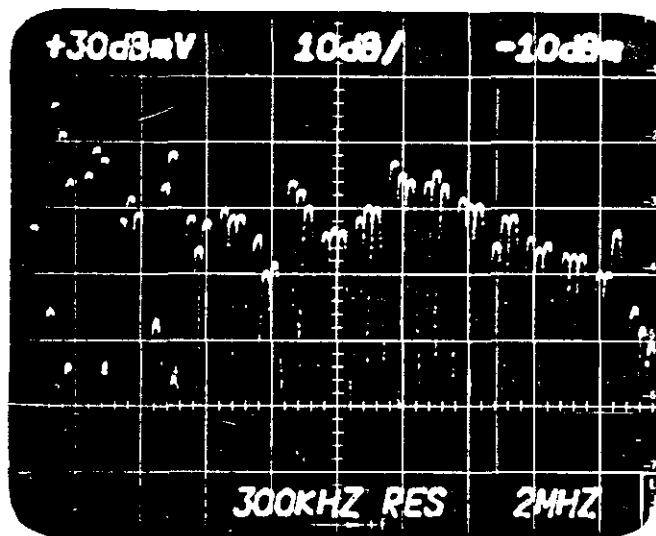

TX & RX ANTENNAS COLLINEAR HMD AT DRIFT CENTER (MIDDLE)

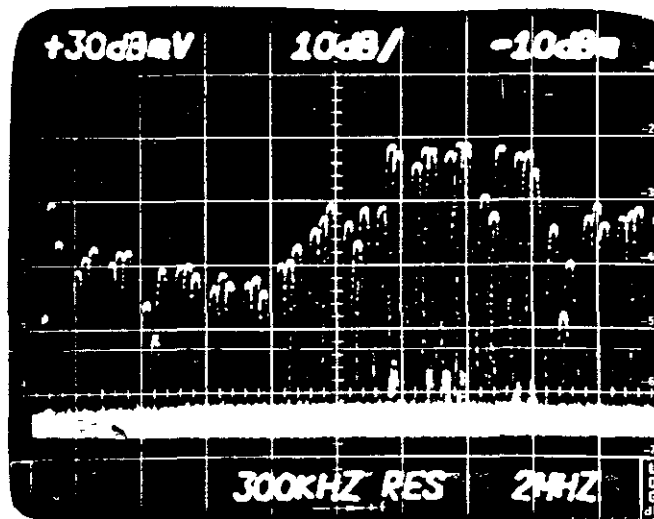

TX & RX ANTENNAS BROADSIDE HMD AT DRIFT CENTER (MIDDLE)

FIGURE 137

ORIGINAL OSCILLOGRAPHS OF HF SWEPT-FREQUENCY
DATA ALONG 3000-LEVEL NORTH CROSSCUT-VMD
CONFIGURATIONS W/O FREQUENCY INDEX REFERENCE
HECLA CON-SIL MINE

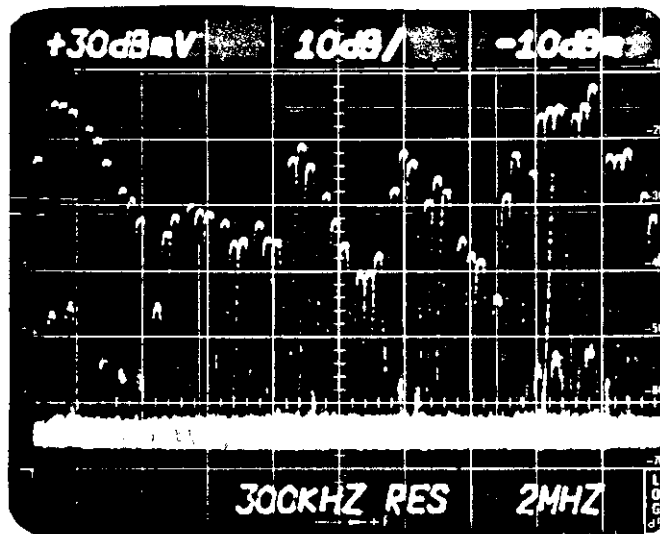

TX & RX ANTENNAS VMD NEAR DRIFT BACK HORIZONTAL
WITH WIRE BUNDLING (TOP)

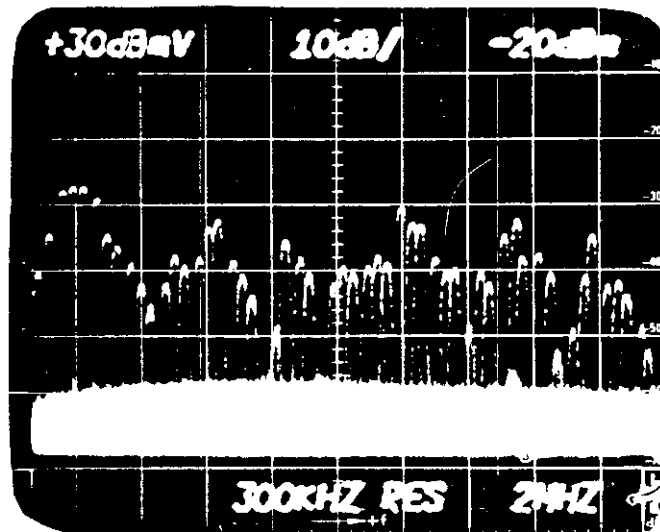

TX & RX ANTENNAS VMD AT DRIFT CENTER (MIDDLE)

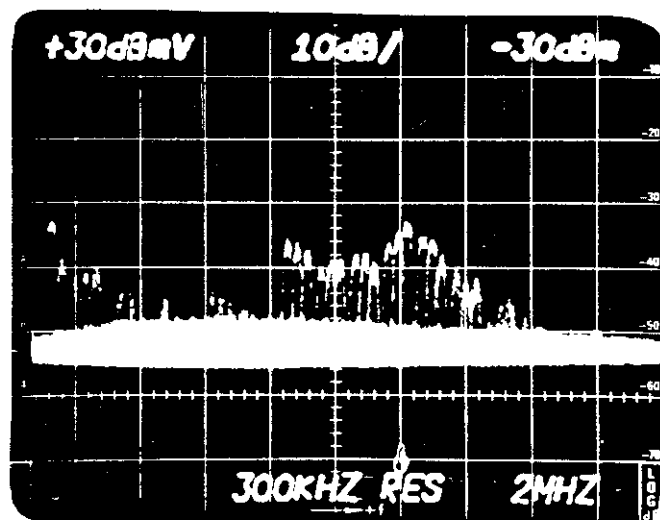

TX & RX ANTENNAS VMD 1-FOOT ABOVE TRACK (BOTTOM)

FIGURE 138

ORIGINAL OSCILLOGRAPHS OF HF SWEEP-FREQUENCY
DATA ALONG 3000-LEVEL NORTH CROSSCUT-PROBE AND
VMD CONFIGURATIONS WITH FREQUENCY INDEX
REFERENCE

HECLA CON-SIL MINE

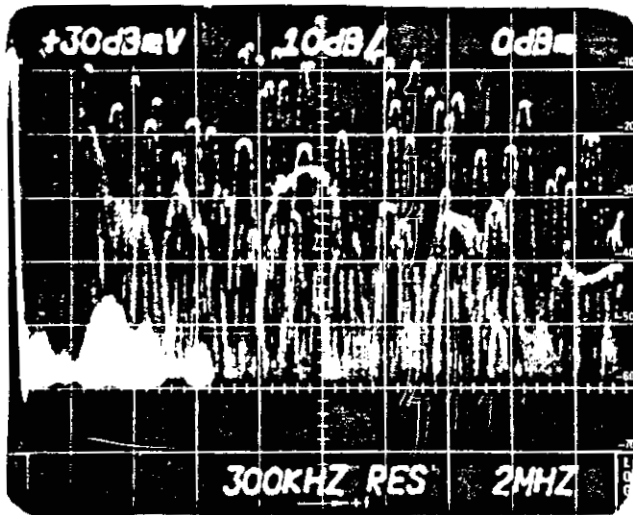

TX & RX CURRENT PROBES WITH 0 DBM INDEX

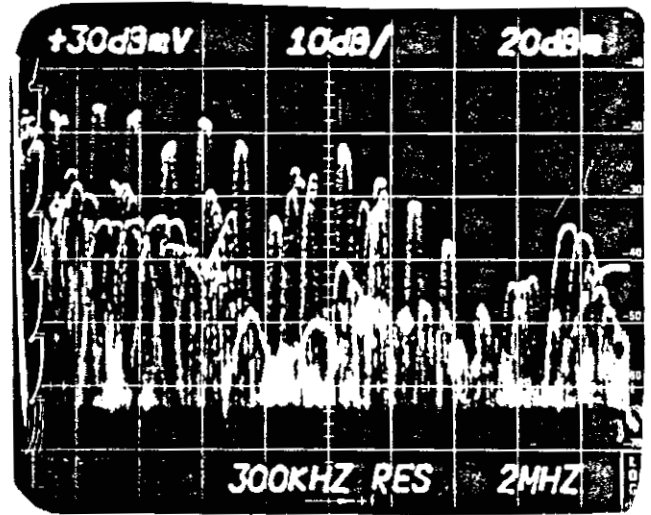

TX & RX CURRENT PROBES WITH 20 DBM INDEX

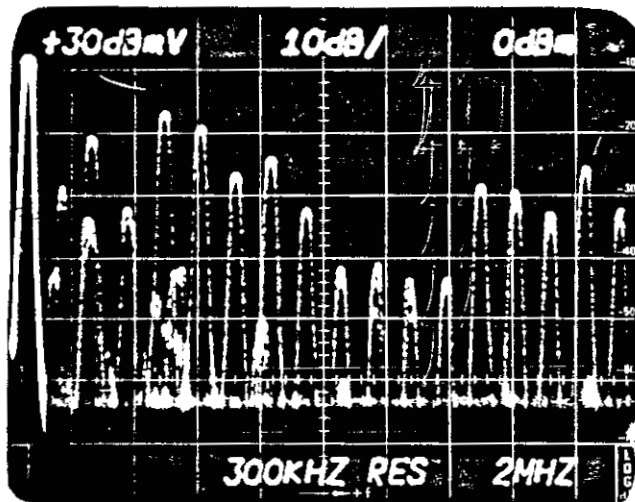

TX & RX ANTENNAS VMD NEAR DRIFT BACK HORIZONTAL
WITH WIRING BUNDLE (TOP)

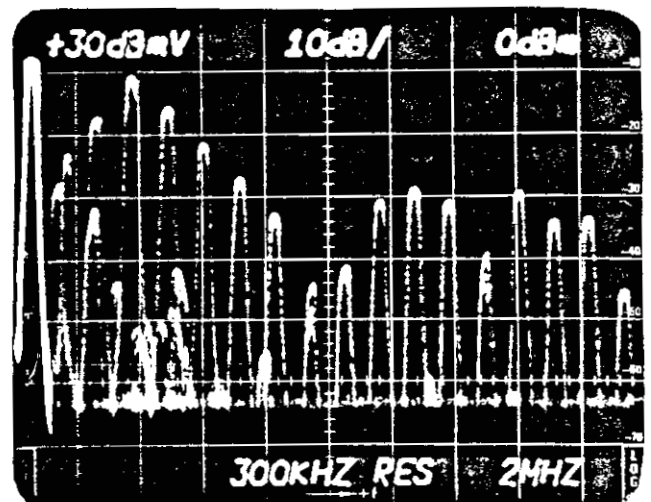

TX PROBE, RX ANTENNA VMD NEAR DRIFT BACK
HORIZONTAL WITH WIRING BUNDLE (TOP)

FIGURE 139

ORIGINAL OSCILLOGRAPHS OF VHF SWEPT-FREQUENCY
DATA ALONG 3000-LEVEL NORTH CROSSCUT WITH
ANTENNAS AT DRIFT CENTER AT LOCATION 1
HECLA CON-SIL MINE

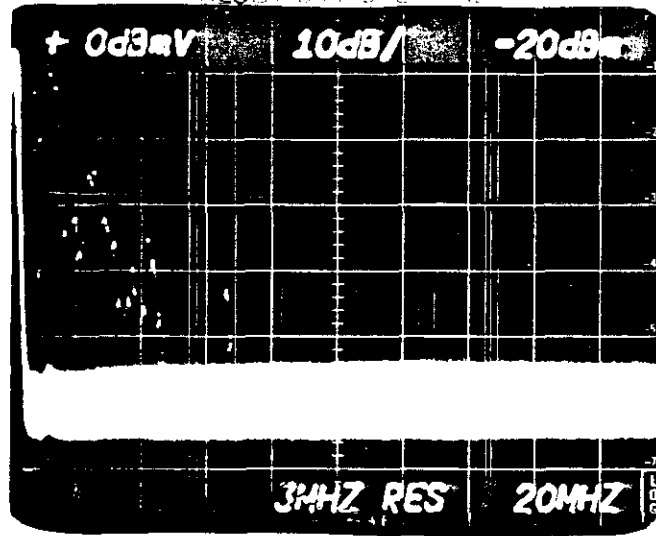

TX & RX CURRENT PROBES

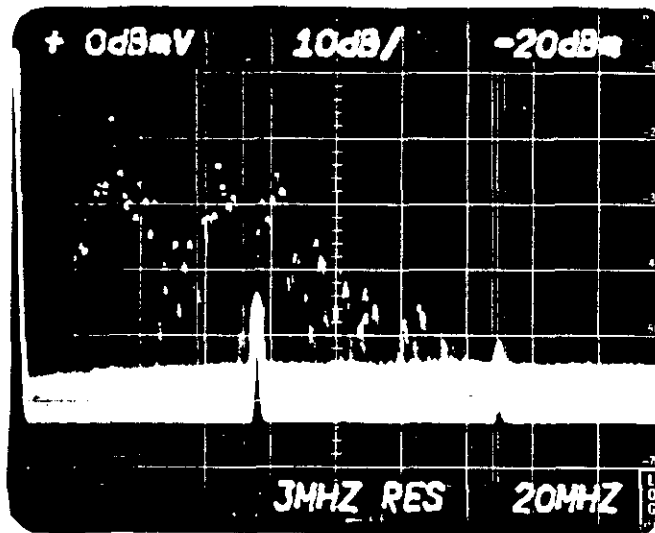

TX & RX ANTENNAS VERTICAL POLARIZATION

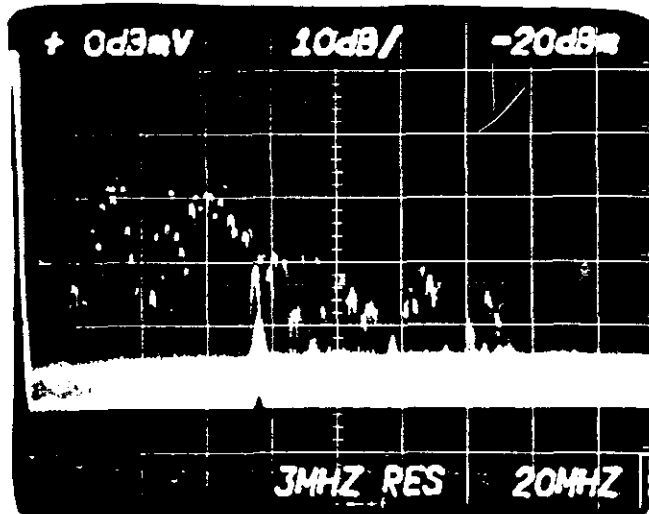

TX & RX ANTENNAS HORIZONTAL POLARIZATION

FIGURE 140

ORIGINAL OSCILLOGRAPHS OF VHF SWEPT-FREQUENCY
DATA ALONG 3000-LEVEL NORTH CROSSCUT WITH
ANTENNAS AT DRIFT CENTER AT LOCATION 2
HECLA CON-SIL MINE

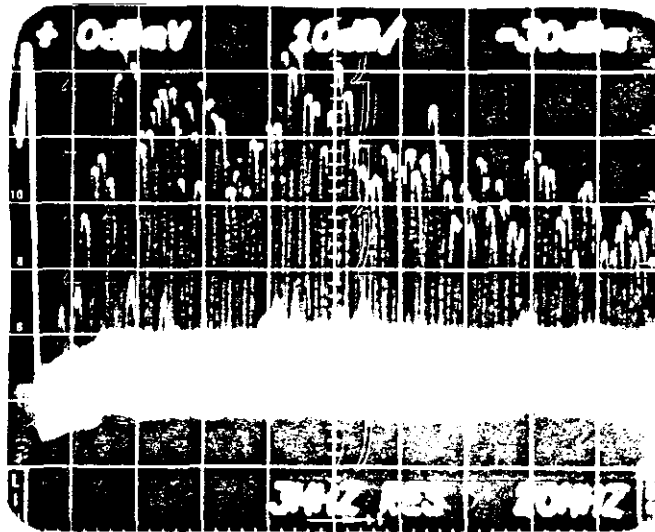

TX & RX ANTENNAS VERTICAL POLARIZATION

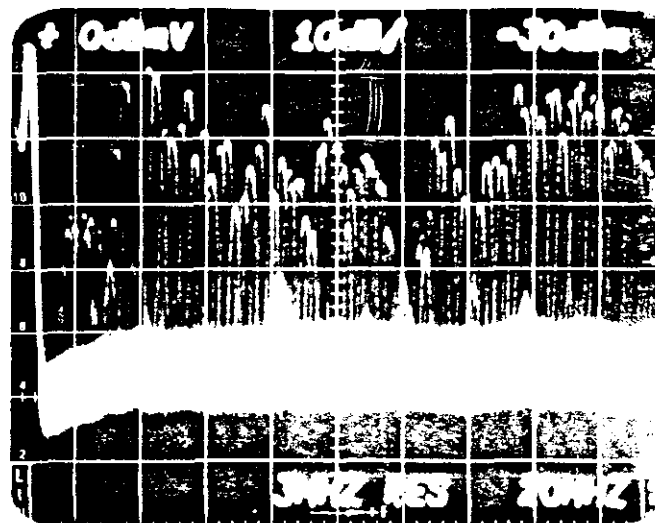

TX & RX ANTENNAS HORIZONTAL POLARIZATION

FIGURE 141

ORIGINAL OSCILLOGRAPHS OF UHF SWEPT-FREQUENCY
DATA ALONG 3000-LEVEL NORTH CROSSCUT WITH
ANTENNAS AT DRIFT CENTER AT LOCATION 1
HECLA CON-SIL MINE

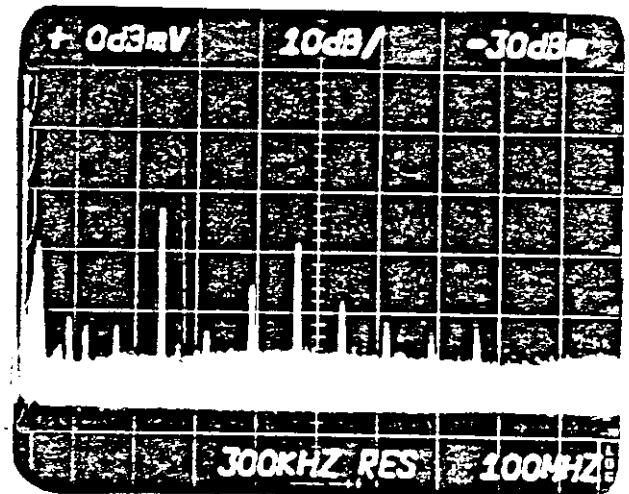
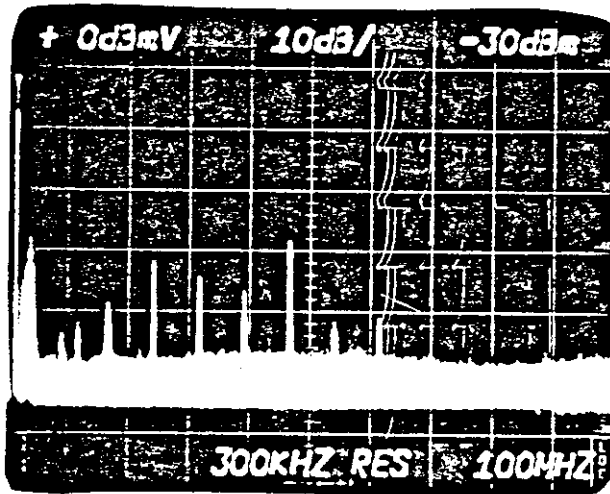

TX & RX ANTENNAS VERTICAL POLARIZATION-BAND 1 TX & RX ANTENNAS VERTICAL POLARIZATION -BAND 2

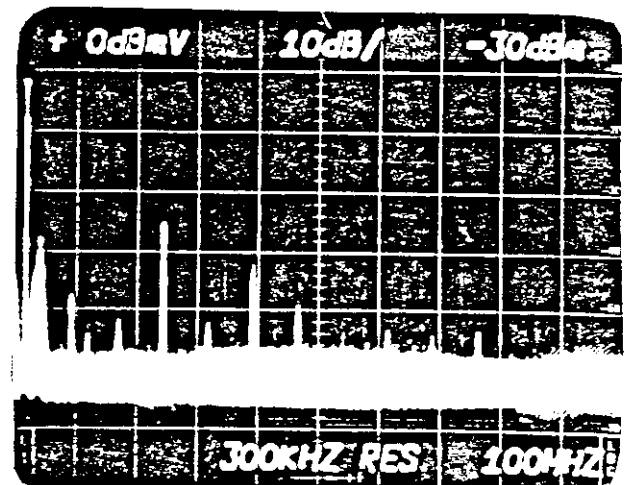
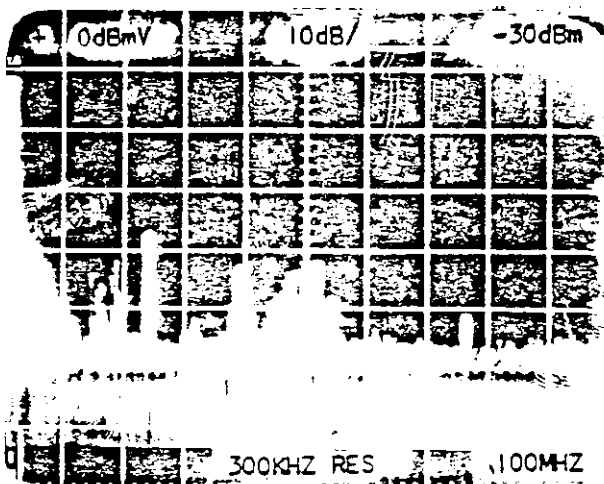

TX & RX ANTENNAS HORIZONTAL POLARIZATION-BAND 1 TX & RX ANTENNAS HORIZONTAL POLARIZATION-BAND 2

FIGURE 142

ORIGINAL OSCILLOGRAPHS OF UHF SWEPT-FREQUENCY
DATA ALONG 3000-LEVEL NORTH CROSSCUT WITH
ANTENNAS AT DRIFT CENTER AT LOCATION 2
HECLA CON-SIL MINE

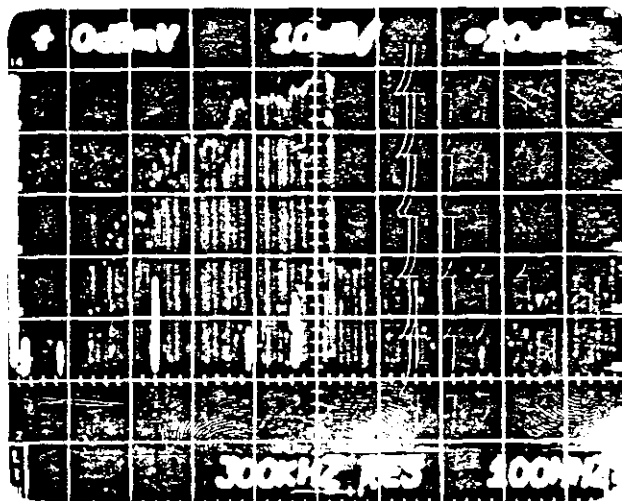

TX & RX ANTENNAS VERTICAL POLARIZATION-BAND 1

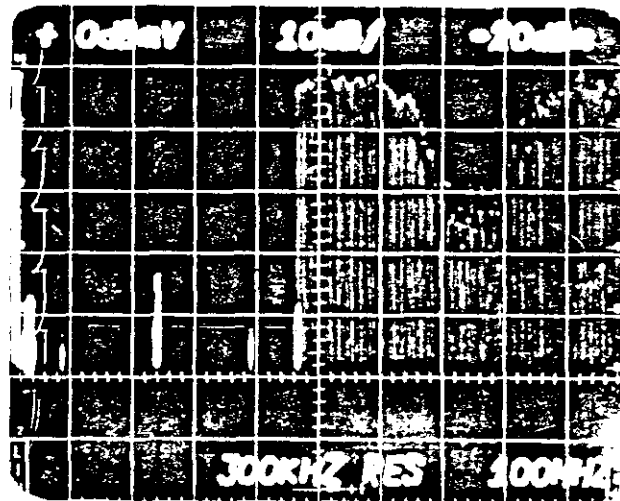

TX & RX ANTENNAS VERTICAL POLARIZATION-BAND 2

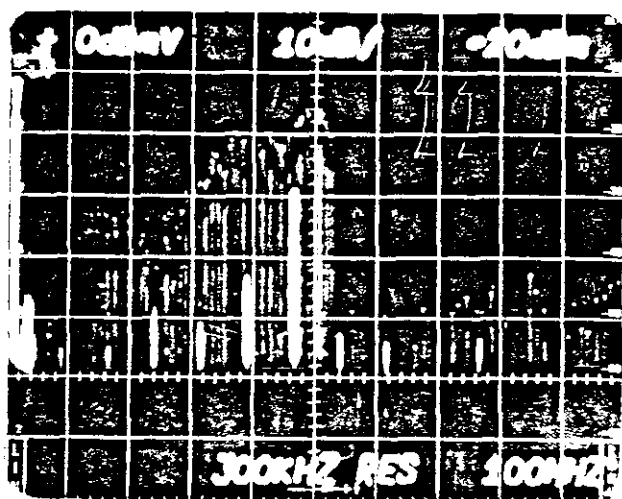

TX & RX ANTENNAS HORIZONTAL POLARIZATION-BAND 1



TX & RX ANTENNAS HORIZONTAL POLARIZATION-BAND 2