

Open file report 209-83

A mining research contract report

AUGUST 1983

REVERSE PERFORMANCE CHARACTERISTICS OF MAIN MINE FANS

Contract J0308044
Engineers International, Inc.

BUREAU OF MINES

UNITED STATES DEPARTMENT OF THE INTERIOR



DISCLAIMER

The views and conclusions contained in this document are those of the authors and should not be interpreted as necessarily representing the official policies or recommendations of The Interior Department's Bureau of Mines or the U. S. Government.

Reference to specific brands, equipment, or trade names in this report is made to facilitate understanding and does not imply endorsement by the Bureau of Mines, the U. S. Government, or Engineers International, Inc.

6-332
(December 1961)



Class _____
Book _____

GPO 781-184

REPORT DOCUMENTATION PAGE	1. REPORT NO.	2.	3. Recipient's Accession No.
4. Title and Subtitle Reverse Performance Characteristics of Main Mine Fans		5. Report Date August 1983	
7. Author(s) M.F. Dunn, S. Bhattacharya, V. Rajaram		6.	
9. Performing Organization Name and Address Engineers International, Inc. 98 E. Naperville Road Westmont, IL 60559		8. Performing Organization Rept. No. 1050	
12. Sponsoring Organization Name and Address Bureau of Mines U. S. Department of the Interior Pittsburgh Research Center, P. O. Box 18070 Pittsburgh, PA 15236		10. Project/Task/Work Unit No.	
		11. Contract(C) or Grant(G) No. (C) JO308044 (G)	
		13. Type of Report & Period Covered FINAL 5/80 - 4/83	
15. Supplementary Notes		14.	
16. Abstract (Limit: 200 words) During a mine fire or other emergency, it may be desirable to reverse the airflow in order to provide an escapeway or to isolate a fire. Also, in colder areas, the airflow may be reversed to prevent ice buildup. When reversing main mine fans, the mine operator usually does not know what operating characteristics of flow and pressure to expect. Laboratory and field tests of vane axial main mine fans in the 7- to 9-ft diameter size range were conducted to establish forward and reverse performance characteristics under controlled conditions and at typical mine installations. The data obtained suggest that reverse performance characteristics are dependent upon the blade angle and the hub to tip ratio. There is also evidence that reverse performance can be predicted for a family of blade angles and a given hub to tip ratio. Generally, quantity of air is 30% to 65% less in reverse than when operating in the normal forward mode.			
17. Document Analysis a. Descriptors Ventilation, Vane Axial Fans, Mines b. Identifiers/Open-Ended Terms c. COSATI Field/Group Field 08/Group I			
18. Availability Statement Unlimited		19. Security Class (This Report) Unclassified	21. No. of Pages 65
		20. Security Class (This Page) Unclassified	22. Price

FOREWORD

This report was prepared by Engineers International, Inc., under USBM Contract No. J0308044. The contract was initiated under the Metal/Nonmetal Mine Health and Safety Program. It was administered under the technical direction of the Pittsburgh Research Center with Mr. E. D. Thimons acting as Technical Project Officer.

Mr. Alan G. Bolton was the contract administrator for the Bureau of Mines. This report is a summary of the work recently completed as a part of this contract during the period May 29, 1980 to April 29 1983. This report was submitted by the authors in August, 1983.

The work on the project was significantly aided by the contributions of Mr. William Bruce of MSHA Technical Support in Denver, CO; Messrs. Ray Schilz and William Meakin of Joy Manufacturing Company; and by the mining companies whose personnel were both patient and cooperative during field testing.

This project was conducted under the technical supervision of Dr. V. Rajaram, with Mr. Michael F. Dunn as Project Engineer and Mr. Swapan Bhattacharya as Staff Engineer, who are the authors of this report. Mr. Francis S. Kendorski provided technical supervision during Phase I and the initial portions of the Phase II field tests. Dr. Madan M. Singh provided overall direction for the project.

TABLE OF CONTENTS

	<u>Page</u>
REPORT DOCUMENTATION PAGE	3
FOREWORD	4
TABLE OF CONTENTS	5
LIST OF FIGURES	6
LIST OF TABLES	7
1.0 INTRODUCTION	8
1.1 Purpose	8
1.2 Objectives	8
2.0 VANE-AXIAL FANS	9
2.1 Characteristics and Use	9
2.2 Reversal Characteristics	9
3.0 LABORATORY TEST RESULTS	12
3.1 AMCA Standards	12
3.2 Project Test Facilities	12
3.3 Test Results	12
3.4 Conclusions	18
4.0 FIELD TEST PROCEDURE	21
4.1 Apparatus Required	21
4.2 Preliminary Data Collection	23
4.3 Equipment Use	25
4.4 Fan Testing Procedure	28
4.5 Computations	31
5.0 FIELD TESTS	34
5.1 Mine No. 1	34
5.2 Mine No. 2	37
5.3 Mine No. 3	41
5.4 Summary of Field Results	50
6.0 GUIDELINES FOR REVERSING FANS	54
6.1 Data Trends from Present Work	54
6.2 Guidelines	54
6.3 Applicability of Guidelines	55
7.0 CONCLUSIONS AND RECOMMENDATIONS	56
7.1 Conclusions	56
7.2 Recommendations for Future Work	56
8.0 APPENDIX A	57

LIST OF FIGURES

<u>Figure</u>	<u>Title</u>	<u>Page</u>
1.	Vane-axial fan	10
2.	Definition of blade angle.	11
3.	AMCA laboratory standard for testing fans.	13
4.	Laboratory fan testing arrangement	14
5.	Test data sheet (from Joy Manufacturing Co.)	15
6.	M96-43 reverse performance summary at various blade angles..	16
7.	M96-58 reverse performance summary at various blade angles..	17
8.	Fan average performance versus blade angle for laboratory data	20
9.	Pitot tube.	22
10.	Field altimeter	24
11.	Pitot tube traverse plane	30
12.	Fan installation at Mine No.1	35
13.	General ventilation arrangement, Mine No.2.	38
14.	Schematic of fan installations in Mine No.2	39
15.	Schematic of fan installations in Mine No.3	46
16.	Computation of total pressure from characteristic curves. .	49
17.	Fan average performance versus blade angle.	52
A1.	Fan performance with 10° blade angle.	58
A2.	Fan performance with 20° blade angle.	59
A3.	Fan performance with 30° blade angle.	60
A4.	Fan performance with 35° blade angle.	61
A5.	Fan performance with 12° blade angle.	62
A6.	Fan performance with 22° blade angle.	63
A7.	Fan performance with 32° blade angle.	64
A8.	Fan performance with 42° blade angle.	65

LIST OF TABLES

<u>Table</u>	<u>Title</u>	<u>Page</u>
1.	Calculated and laboratory test data comparison. . .	19
2.	Performance comparison for fan 1.	36
3.	Performance comparison for fan 2.	40
4.	Performance comparison for fan 3.	42
5.	Performance comparison for fan 4.	43
6.	Performance comparison for fan 5.	44
7.	Performance comparison for fan 6.	47
8.	Performance comparison for fan 7.	48
9.	Field test data summary	51

1.0 INTRODUCTION

Ventilation is an essential part of any underground mining operation. The principal functions of the ventilating air consist of providing oxygen to persons and equipment, dilution of gaseous pollutants, transport of dust, and cooling (or heating). The mine fan supplying the ventilating air may be either a forcing or an exhausting type and, under normal operating conditions, is run in one direction only.

During a mine fire or other emergency, however, it may be desirable to reverse the airflow in order to provide an escapeway or to isolate a fire. Additionally, ice buildup in a shaft can be detrimental and many mines that employ vane-axial fans reverse their airflow during winter in order to course warm exhaust air (heated by the mining equipment or natural rock temperature) through the shaft and adits thereby limiting such buildups. However, when a mine reverses its airflow by electrically reversing its main mine fan, it usually does not know what operating characteristics of flow and pressure to expect. The laboratory and field testing in this project helped provide such answers.

1.1 Purpose

The project was accomplished in two phases. The purpose of Phase I was to test and establish main mine fan characteristics in the reverse direction, under laboratory conditions. To carry out this work, EI subcontracted with Joy Manufacturing Company of New Philadelphia, Ohio, to test two (2) common main mine fans each of 96-in. (2.4-m) diameter but with different hub to tip ratios. The laboratory testing was conducted within the first two weeks of March 1981.

The purpose of the second phase was to estimate reverse characteristics of mine fans under actual mining conditions. To that end, seven (7) fans were tested at several mines around the country.

1.2 Objectives

The objective of the laboratory testing was to develop performance data in forward and reverse directions under reasonably controlled conditions. From these data, reverse fan performance estimates were made. The laboratory data also served as a base for comparing results of similar fan testing in the field. A secondary benefit from developing these data was that they served as a good comparison to the calculated performance scaled from smaller fans tested in the laboratory (by means of fan law relationships).

The objective of the field testing was to verify the laboratory results by testing under actual mining conditions. It was anticipated that multiple fan installations, air doors and regulators, and auxiliary fans would affect reverse fan performance and its predictability. Consequently other parameters not found in the laboratory would need to be considered when evaluating field tests.

2.0 VANE-AXIAL FANS

2.1 Characteristics and Use

Vane-axial fans, first developed in the 1930s, are the most common type of fans used in mines today. In order to cause airflow these fans create a pressure difference in an airway. Vane-axial fans accelerate the air through the fan, which results in both a pressure and velocity increase. Fans must supply enough pressure to overcome system pressure head losses and deliver the required air quantity. Therefore, one reason for vane-axial fan popularity is the versatility of adjustment to a wide range of performance requirements. These fans basically consist of a cylindrical impeller within a fan housing. The impeller has air-foil blades causing airflow through the fan axially, that is, parallel to the rotation axis.

Figure 1 illustrates the basic design of a typical vane-axial fan. The inlet bell and outlet cone help to improve the efficiency of moving air by reducing turbulence. The main fan parts are the blades, rotor or hub, diffuser tail, straightening vanes, and drive shaft.

The hub to tip ratio, which will be referred to often, is simply the ratio of the hub radius (distance from the fan center to the base of the blade) to the tip radius (distance from the fan center to the blade tip). The vane-axial fans tested have variable pitch blades which can be set to a particular angle. An illustration of the blade angle setting is shown in Figure 2.

Blade settings on fan manufacturers' characteristic curves are often expressed by a number which corresponds to a blade angle. The number and corresponding angle varies among manufacturers, hence reference is made to blade angle rather than blade setting throughout this report.

2.2 Reversal Characteristics

Mines often use vane-axial main fans because of flexibility in installation and performance, and lower power consumption. However, these fans perform very inefficiently when reversed, their output being reduced considerably.

Problems involved with reversed main fans go beyond the limitations of the fan itself. With the main mine fans reversed, auxiliary fans in the mine could still be circulating air in their normal direction, adding increased resistance to the main fans. After reversal of the main mine fans, the previously established airflow movement in the mine must be overcome which could take some time to reach steady-state flow. Any natural ventilation effect present can either aid the fan or add increased resistance depending on conditions. Thus, the field testing of main mine fans involves many other factors that could influence performance.

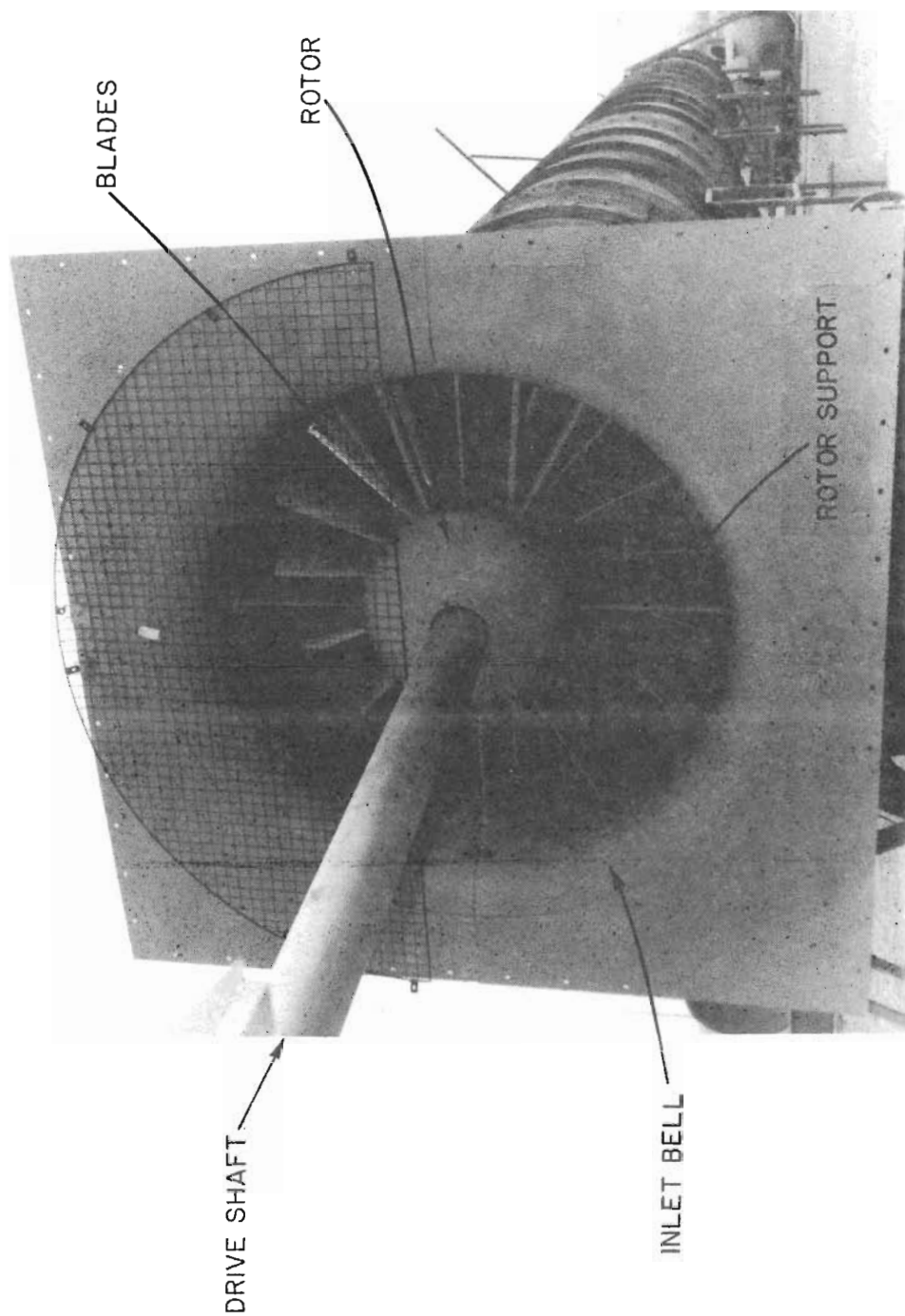

FIGURE 1. - Vane-axial fan.

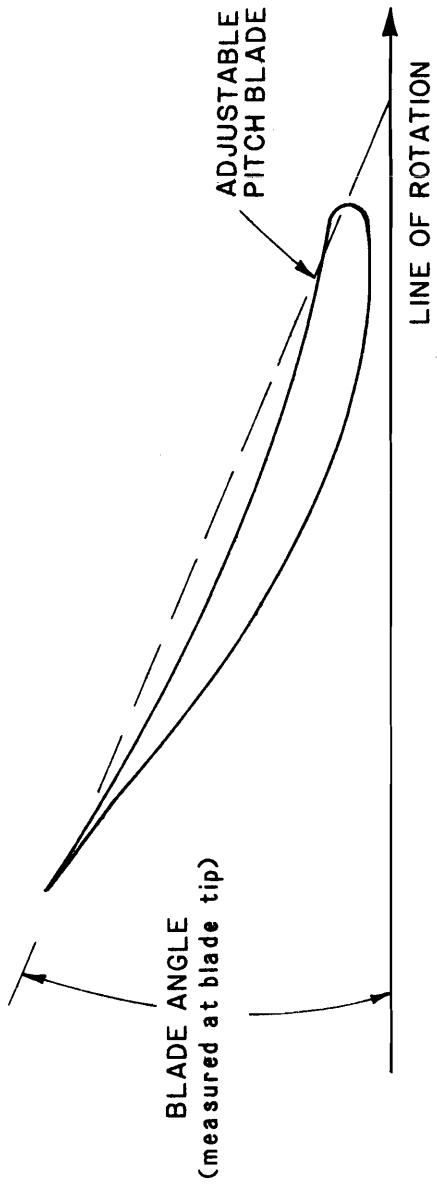

FIGURE 2 - Definition of blade angle.

3.0 LABORATORY TEST RESULTS

Laboratory tests of vane-axial fans, in both forward and reverse, were conducted at the Joy Manufacturing Company's facilities in Ohio. Test procedures and results are provided in this section of the report.

3.1 AMCA Standards

The Air Moving and Conditioning Association, Inc. (AMCA) has developed standards for testing fans which include testing equipment and testing facilities¹. The purpose of such standards is to assure uniformity of fan ratings. Figures 3a and 3b illustrate test facilities according to AMCA Standard 210-74 for laboratory testing of fans in both forward and reverse directions.

3.2 Project Test Facilities

Figure 4 shows the fan test arrangement at Joy Manufacturing Company (Joy). Two fans were tested at 720 rpm for four different blade angles in both the forward and reverse directions. A minimum of six determinations were taken at each blade angle. For each determination, readings of pressure heads, power input, rpm, wet and dry bulb temperature, and barometric pressure were recorded. All information was recorded on standard data sheets similar to the one shown in Figure 5.

3.3 Test Results

A series of performance curves, for each fan tested, are presented in Appendix A, showing forward and reverse performance (with reverse flow shown as a percentage of forward flow), and input horsepower for each blade setting. In addition to these fan curves, reverse fan performance summary curves showing the relationship between reverse and forward flow, for each fan and blade angle, are presented in Figures 6 and 7. Data points for these figures have been obtained from the corresponding performance curves included in Appendix A.

3.3.1 Calculated Versus Test Data

To accurately establish the percent of reverse flow (as compared to forward performance), it was decided that the forward performance should first be established, rather than accept the data presented in Joy's catalog.

The catalog data were found to be reasonably accurate when compared to the test results. Nevertheless, the curves presented in this report are derived from actual tests and not taken from the mine

¹Air Moving and Conditioning Association, Inc. Laboratory Methods of Testing Fans for Rating Purposes. AMCA Standard 210-74, ASHRAE Standard 51-75, 1975.

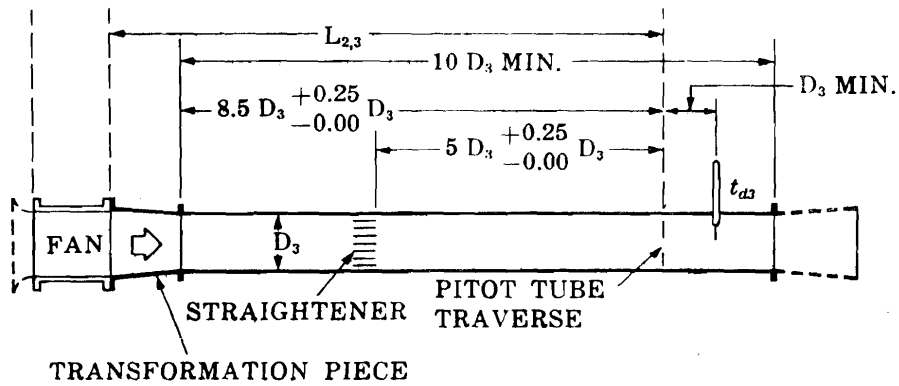

(a) Pitot traverse in outlet duct

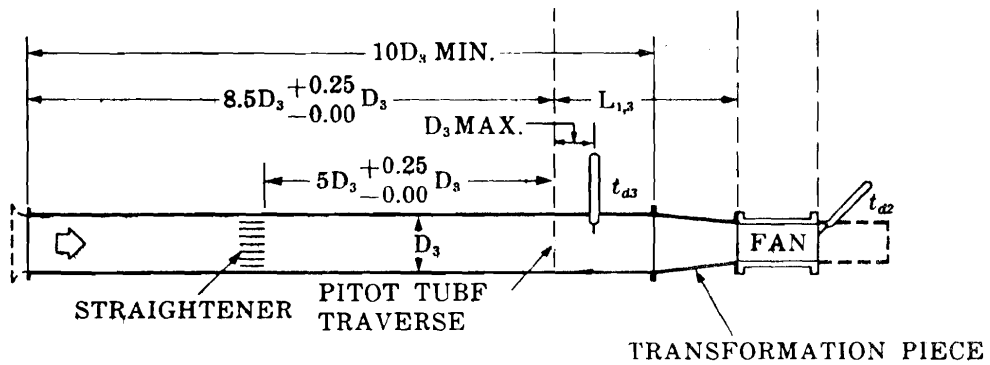

(b) Pitot traverse in inlet duct

FIGURE 3. - AMCA laboratory standard for testing fans.

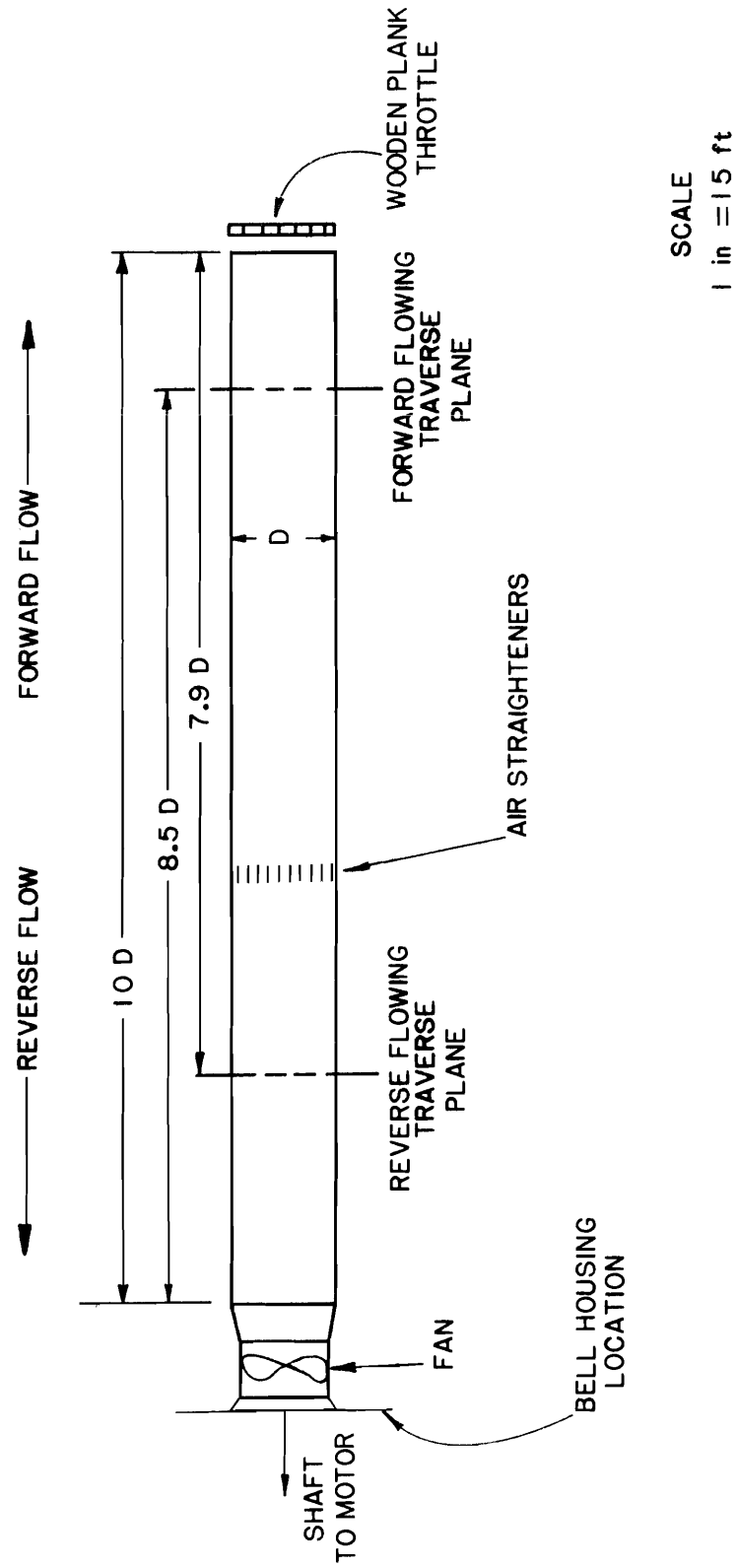

FIGURE 4. - Laboratory fan testing arrangement.

DATE _____
 SHEET _____ OF _____ SHEETS

BLOWING OR EXHAUSTING TEST

PRESSURE SURVEY				AIR - POWER - SPEED DATA				
	P _s	P _v	√P _v	ROOM AIR DATA °F				
1				DB	WB	BAROMETER	AIR DENSITY	
2								
3				CONDITION	AMPS	VOLTS	WATTS	RPM
4								
5				TEST				
6								
7				CORR. TO				FREQ.
8				0.075 DENS.				
9				METER BURDEN				
10				DUCT AIR DATA °F				
11				TEMP.		AIR DENS.		
12				0.075		1096		
13				Density "		√Density "		
14								
15				Duct		Duct		
16				Area "	Ft ²	Dia.		In.
17								
18				Duct Friction P _f "				
19								
20				P _v Correction				
21								
22				SHUTOFF				
23				AMPS =		EFF _{motor} =		
24				VOLTS =		RMP =		
TOTAL				WATTS =		P _s =		
AVG.								

	FINAL VALUES
(1) Vel = (Av. P _v × 1096 / √Air Dens.)	FFM
(2) Vol = Vel × Duct Area	CFM
(3) pt = Av. P _s + Av. P _v	"W.G.
(4) P _v = Av. P _v × 0.075 / Dens.	"W.G.
(5) P _v ' = P _v × P _v Correction	"W.G.
(6) P _t = pt × 0.075 / Dens. + (P _v × P _f)	"W.G.
(7) P _s = P _t - P _v '	"W.G.
(8) AHP = Vol × P _t	AHP
(9) IHP = Watts × 0.075 / Dens.	IHP
(10) BHP = IHP × EFF _{motor}	BHP
(11) EFF _{total} = (AHP/BHP) × 100	% EFF _{total}
(12) EFF _{static} = EFF _t × (P _s /P _t)	% EFF _{static}
(13) EFF = (AHP/IHP) × 100	% EFF

FIGURE 5. - Test data sheet
 (from Joy Manufacturing Co.).

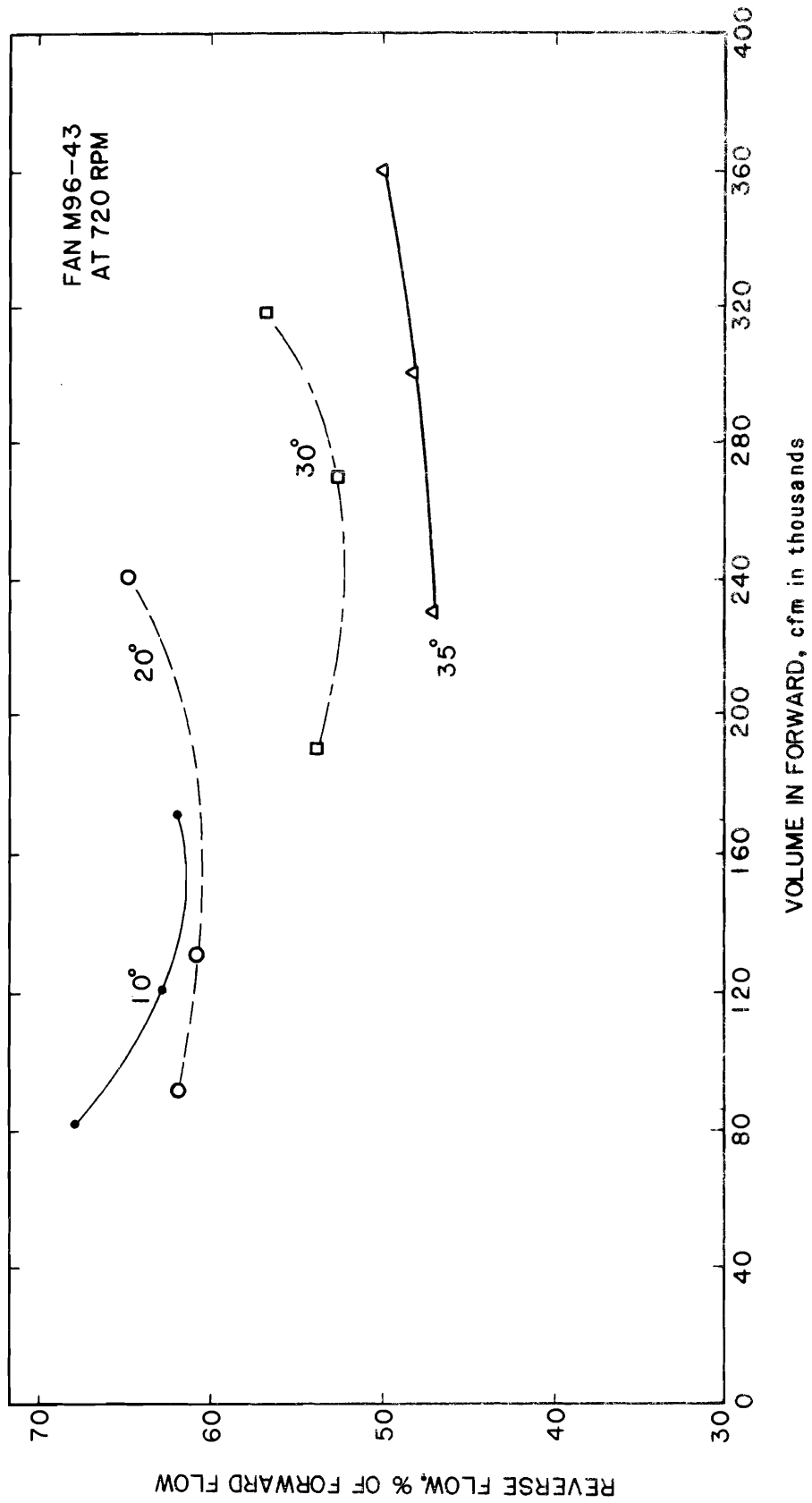

FIGURE 6. - M96-43 reverse performance summary at various blade angles from laboratory fan performance curves shown in Appendix A.

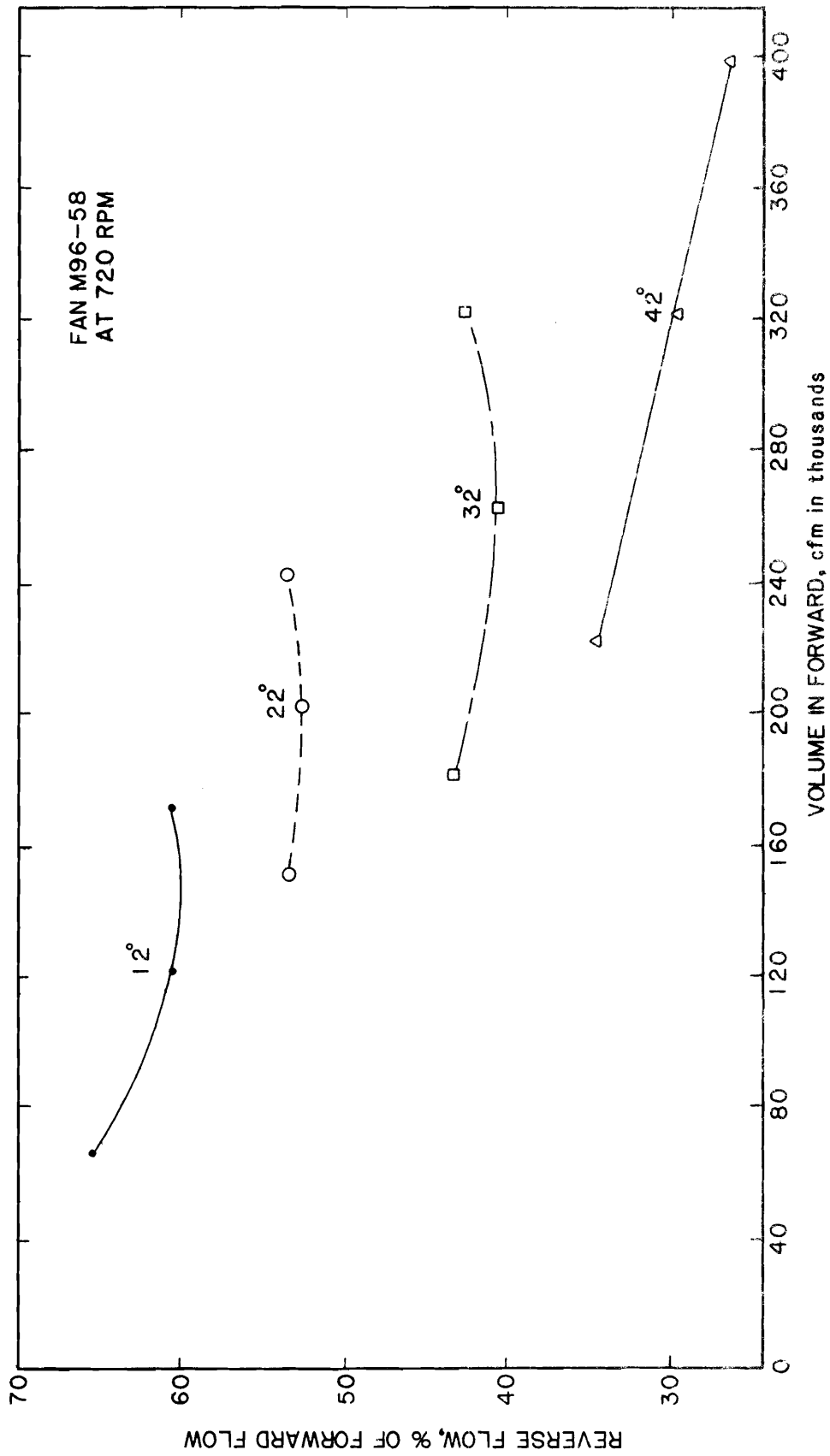

FIGURE 7. - M96-58 reverse performance summary at various blade angles from laboratory fan performance curves shown in Appendix A.

fan catalog. Table 1 is the result of a random comparison between calculated and laboratory test data for the M96-58 fan at the tested blade angles. The difference between the corresponding calculated and tested data points is consistently less than 10%; often less than 5%.

3.3.2 Forward versus Reverse Performance

Analysis of Figures 6 and 7 reveals an inverse relationship between performance and corresponding blade angles. However, due to limitations of data, the applicability of this relationship to other types of fans and hub to tip ratios is not known.

Analysis was carried further by plotting the average reverse percent of forward performance, from curves in Figures 6 and 7, against blade angle, as shown in Figure 8. The results show a well defined curve for each hub to tip ratio tested. Adopting these curves to fans of other hub to tip ratios may be premature at this time, although, the data strongly suggest that such a relationship may exist for a given hub to tip ratio.

3.3.3 Pressure and Volume

In general, the results indicate that fan static pressure (P_s) changes as the square of the volume (Q):

$$P_s \propto Q^2$$

For example, if the volume in the reverse direction is reduced to 60 percent of the forward value, the pressure available from the fan will be reduced to about 36 percent. This relationship has been reported in previous studies of smaller fans².

3.4 Conclusions

Laboratory testing has shown that reverse flow is not a constant percentage of forward flow but depends upon blade angle and hub to tip ratio. In addition, the fan law governing the pressure-volume relationships in vane-axial fans appears to be valid for reverse flow. Field testing of main mine fans was undertaken to assess the validity of these generalizations over a wider range of hub to tip ratios. The results are presented in the following sections.

²Western Engineering and Manufacturing Company. Product Information Handbook. Bulletin No. H-78, 1978, p. 7.18.

TABLE 1. - Calculated and laboratory test data comparison for Joy Model M96-58 fan in forward mode

<u>Blade Angle, degrees (rad)</u>	<u>Volume, cfm (m³/s)</u>		<u>Percent Error</u>
	<u>Calculated</u>	<u>Measured</u>	
12 (0.21)	104,000 (49.1)	105,000 (49.5)	-0.95
12 (0.21)	130,000 (61.4)	140,972 (66.5)	-7.78
22 (0.38)	185,000 (87.3)	196,388 (92.7)	-5.80
22 (0.38)	212,000 (100.0)	230,416 (108.7)	-8.00
32 (0.56)	270,000 (127.4)	270,278 (127.5)	-0.10
32 (0.56)	300,000 (141.6)	315,000 (148.6)	-4.76
42 (0.73)	310,000 (146.3)	301,388 (142.2)	+2.86
42 (0.73)	365,000 (172.2)	359,722 (170.0)	+1.47

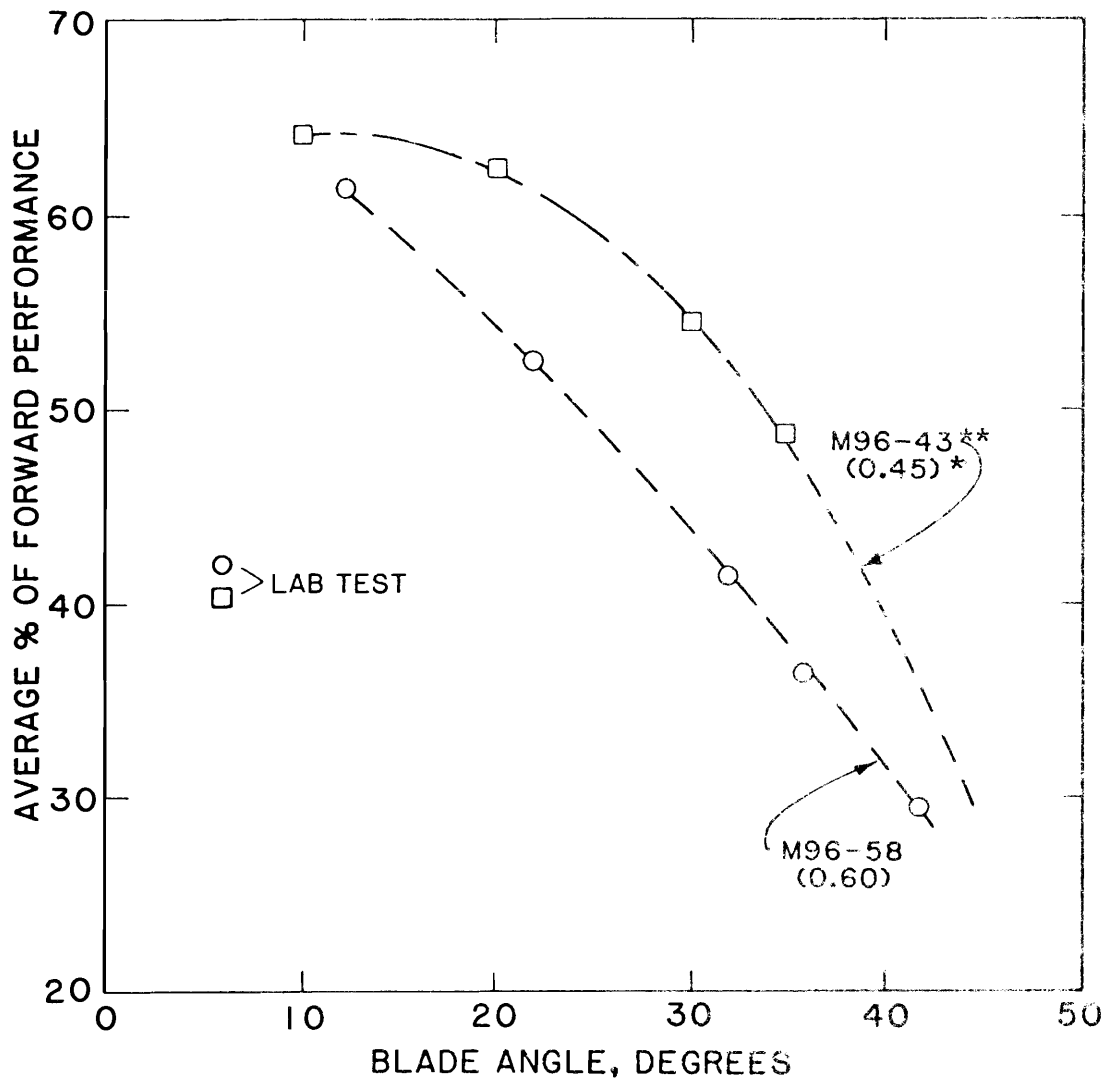

FIGURE 8. - Fan average performance versus blade angle for laboratory data.

*Figures in parentheses refer to hub to tip ratios

**Fan model number

4.0 FIELD TEST PROCEDURE

Field tests were conducted on seven (7) main mine fans located in three (3) mines in the United States. Details of the field test procedure used in these tests is provided in this section.

4.1 Apparatus Required

The following test equipment were used:

- pitot tube
- Magnehelic gauge
- sling psychrometer
- electric thermometer
- altimeter/barometer
- stroboscopic tachometer.

4.1.1 Pitot Tube

The pitot tube is a standard air velocity instrument, especially suited for measuring high velocities encountered with main mine fans. The pitot tube is made of two concentric tubes, one inside the other, with one end bent at a right angle and the other end provided with fittings for each tube, to which a pressure gauge or manometer can be attached (Figure 9). The inside tube receives the total pressure of the airstream and the outer tube, closed on the end, receives the static pressure of the airstream through a number of pinholes set back from the end. When the leads from the pressure gauge are attached to the pitot tube, the gauge registers the difference in pressure between the inner and outer tubes, namely, the velocity pressure. With one lead from the pressure gauge open to the atmosphere, connecting the other lead to the outer tube yields static pressure, and to the inner tube gives total pressure.

Pitot tubes are commercially available in a wide range of sizes. Since the diameters of the fans tested were between 7 to 9 ft, a 5-ft long pitot tube was used to ensure that the pitot tube was of sufficient length to reach all necessary measuring points in the air duct.

4.1.2 Magnehelic Gauge

The Magnehelic gauge was used with the pitot tube for the pressure measurements. This aneroid type gauge is suitable for measurement of the relatively low pressures encountered in ventilation studies. Taking a pressure reading simply involves connecting the high pressure lead from the pitot tube to the high pressure inlet connector on the gauge, the low pressure lead to the other connector, and reading the position of the pointer on the dial. The principal advantages of this type of gauge over the more commonly used U-tube

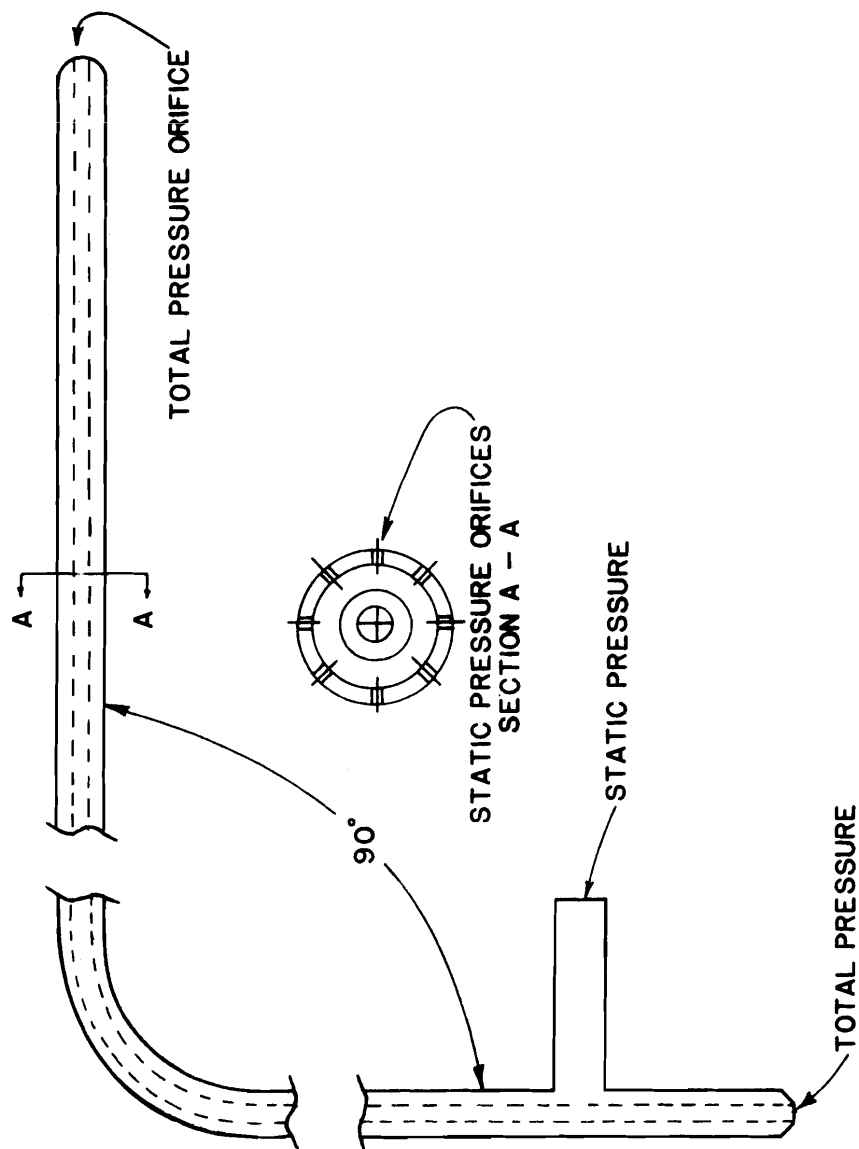

FIGURE 9. - Pitot tube.

manometer are easy reading, portability, and absence of fluid which leads to easier maintenance and use in any position.

4.1.3 Sling Psychrometer

Humidity measurements were taken using the sling psychrometer, which consists of two thermometers mounted side by side on a rigid frame. One of the thermometers, referred to as the wet bulb, is covered with a wick of muslin cloth moistened with distilled water. A handle is provided at one end, which is used to rotate the instrument to increase the rate of water evaporation from the wick causing a cooler temperature reading. Based on the dry- and wet-bulb readings, the relative humidity of the air can be calculated.

4.1.4 Electric Thermometer

The electric thermometer was used to measure the air temperature within the fan ducting by inserting a temperature sensitive probe through a hole in the ducting.

4.1.5 Altimeter

The American Paulin System altimeter was utilized to measure barometric pressure at the test sites. This precision instrument works on the principle of aneroid barometers but is free from most of the instrumental errors inherent in the ordinary aneroid. Figure 10 shows the component parts of a Micro-series altimeter having an accuracy to the nearest foot.

4.1.6 Stroboscopic Tachometer

Fan speed was measured with a stroboscopic tachometer. This device emits a flash of light having a high intensity but short duration. An electronic pulse generator controls the frequency. The unit is hand held, and flashes are bright enough for use in daylight. The fan speed is related to the frequency of the strobe, and can be read directly on a scale.

4.2 Preliminary Data Collection

Before fan testing, some preliminary data were gathered at each mine site. First, the mine map was studied in detail with special emphasis on the overall ventilation scheme. Pertinent data included:

- location of shafts and adits
- location and layout of intake and return airways
- distribution of seals and stoppings
- position of main mine fans

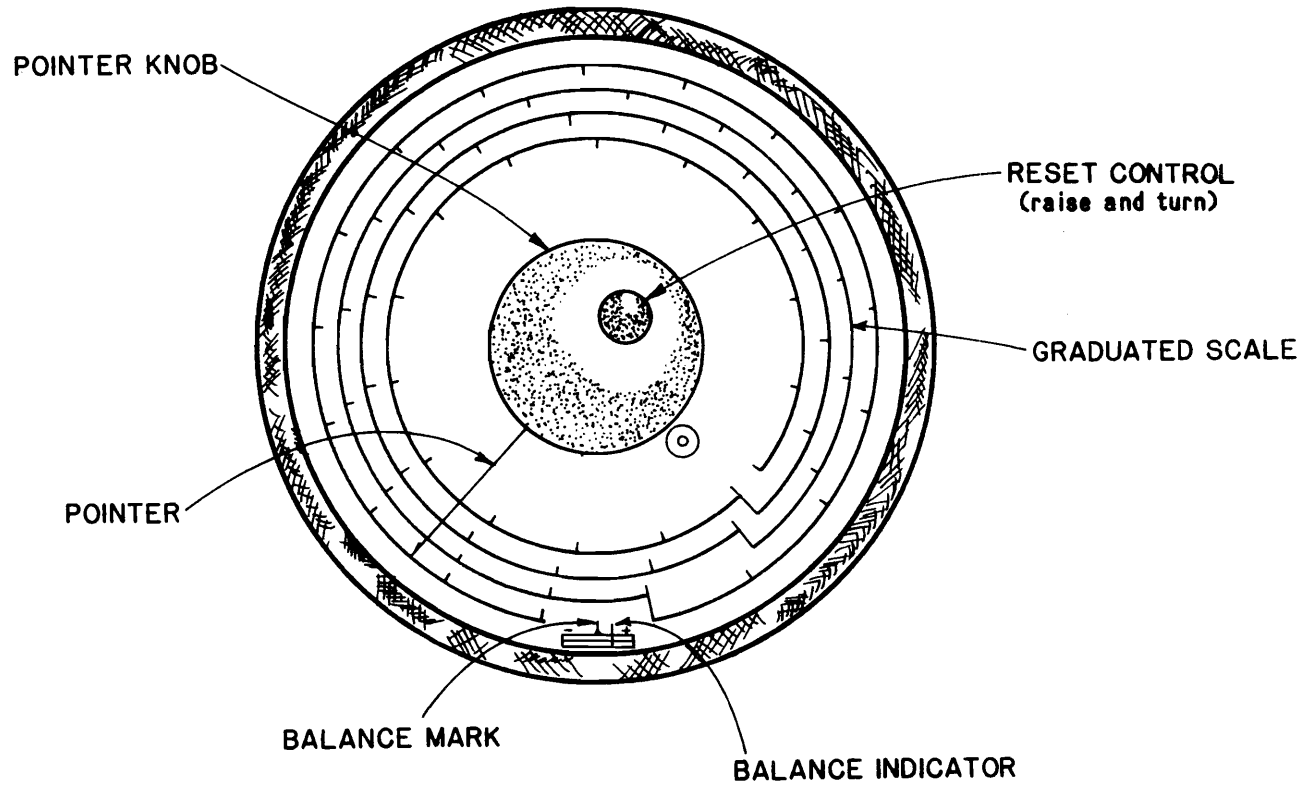

FIGURE 10. - Field altimeter.

- position of auxiliary fans and their capacities
- location and type of ventilation doors
- prior mine experience on fan reversal.

Where a mine had more than one operating fan, the possible influence that the reversal of one fan would have on the others was examined before planning the test sequence. For instance, if two fans were operating in parallel, both would be reversed simultaneously, while fans located on two corners of the property could be reversed separately.

Second, specific information of the fan installation was recorded. This included knowledge of:

- type of fan - blowing or exhausting
- position of the fan - vertical or horizontal
- fan ducting
- accessibility
- location of access holes for pressure survey purposes
- location of guide vanes.

Finally, fan details were obtained from fan manufacturers, mine personnel and name plates mounted on the fan assembly. Briefly, this included:

- fan performance curves
- dimensions of the component parts of the entire fan installation, such as, blade tip diameter, hub diameter, duct diameter and length, blade angle, and bell angles.
- drive motor specifications.

4.3 Equipment Use

4.3.1 Pressure Readings

Reference marks were made on the pitot tube corresponding to the distances of the measurement points from the circumference of the air duct. The pitot tube was introduced through an access hole in the ducting, and was positioned at each measurement point with the nose of the tube pointed upstream. The Magnehelic gauge was connected to the pitot tube by means of two flexible tubes. By making the appropriate connections, velocity pressure, static pressure and total pressure were measured. This process was repeated until measurements at each traverse point were completed.

Since the airflow at the traverse plane was never steady, pressure readings indicated on the Magnehelic gauge fluctuated considerably. Each pressure reading was, therefore, averaged on a time weighted basis.

The following precautions were observed during the test:

- the pitot tube was checked before use to ensure that it was thoroughly clean
- the Magnehelic gauges were calibrated prior to testing
- pitot tube perpendicularity to the airstream was closely watched
- care was taken in connecting the pitot tube to the Magnehelic gauge with regard to anticipated pressures, that is, whether the pressures were negative or positive and whether the scale was appropriate
- kinks in the flexible tubing were avoided.

4.3.2 Measurement of Temperature and Humidity

The wet bulb of the sling psychrometer was soaked with distilled water before proceeding with the temperature readings. With the handle held firmly, the instrument was rotated at an uniform rate until both the wet- and dry-bulb readings remained constant. The readings were repeated after 5-10 minutes. Wet- and dry-bulb temperatures were recorded at the time of each fan test.

While testing fans in the exhausting mode, wet- and dry-bulb readings of the intake air were taken by inserting the psychrometer through one of the traverse holes into the duct.

The following precautions were observed in the course of making the temperature measurements:

- when the thermometers were read, neither the frame nor the thermometers were allowed to come directly in contact with the hand
- the wick on the wet-bulb was thoroughly wetted after making sure that it was clean and closely fitted
- both thermometers were read with minimum time delay
- the psychrometer was held away from the body or any other source of heat
- the thermometers were calibrated before the test to ensure that the readings were accurate to 2⁰ F.

4.3.3 Measurement of Barometric Pressure

The following procedure was adopted for the measurement of barometric pressure:

a) At the place of known elevation:

- the altimeter was placed on the benchmark
- approximately 10-15 minutes are allowed to elapse for the altimeter to adjust to the ambient temperature
- the altimeter was leveled by means of the circular level
- the instrument was balanced by bringing the balance indicator needle to the center of its run by turning the pointer knob
- the pointer needle was set at the elevation of the benchmark by turning the Reset Control knob.

b) At the test site:

- the altimeter was placed in the airstream for exhausting fans if possible, or placed outside the airstream for blowing fans
- the altimeter was allowed to adjust to ambient conditions and leveled
- the instrument was balanced by means of the pointer knob
- the altitude and pressure as indicated by the pointer was recorded.

The following precautions were taken to ensure accuracy:

- the altimeter was protected from the direct rays of the sun
- care was taken when placing the altimeter at the test site so that the temperatures at the top and bottom of the altimeter did not vary significantly
- the instrument was always balanced from the positive side of the window
- parallax errors were avoided while reading the position of the pointer needle
- since two observers seldom obtain exactly the same reading from a particular altimeter, one person was assigned to the job

- the test value of barometric pressure was determined by averaging measurements made at the beginning and end of the test period.

4.3.4 Measurement of Fan Speed

Fan rpm was estimated using a stroboscopic tachometer. The basic requirement for this test is that the fan blades should be visible by the strobe light. Where the fan installation was vertical, measurement of fan speed was not possible.

The stroboscope was held before the rotating fan and the strobe light allowed to shine on the blades. The adjusting screw was turned until the fan blades appeared stationary. Knowing the approximate range of rpm from manufacturer's data, the fan speed was measured and recorded.

4.4 Fan Testing Procedure

The fan test at any field site was a two-step operation - first with the fan operating normally (forcing or exhausting, as the case may be) and later upon reversal. Fan reversal was normally achieved by interchanging the electrical connections. Sufficient time was allowed to elapse after reversal for the entire airflow through the mine to reach steady state.

The operations performed during each step of the test were identical and basically consisted of determining the fan flow rates and pressure heads developed, by means of a pitot tube traverse. Concurrently with the pitot tube traverse, measurements were taken to determine air density. This included wet- and dry-bulb thermometer readings, and barometric pressure. In addition, with the fan in operation, voltage and current readings were taken to determine fan power input. Finally, the fan speed was measured by means of the stroboscopic tachometer. All information was recorded on field data sheets. Details on the various parts of the test follow.

4.4.1 Pitot Tube Traverse

4.4.1.1 Location of Traverse Plane

Choice of the traverse planes for the pitot tube survey were made judiciously to ensure accuracy. Guidelines for location in the duct include³:

³Air Moving and Conditioning Association, Inc. A Guide to the Measurement of Fan-System Performance in the Field. AMCA Fan Application Manual, Part 3, Publication 203, 1976.

- "the velocity distribution should be uniform throughout the traverse plane. It is recommended that the uniformity distribution be considered acceptable when more than 75% of the velocity pressure measurements are greater than 1/10 of the maximum measurement"
- the airstream should be as nearly at right angles to the traverse plane as possible, although a 10 degree (0.17 rad) deviation is acceptable
- the cross-sectional shape of the airway in which the traverse plane is located should be uniform
- the traverse should be made 7.5 duct diameters or more downstream from any major air disturbance such as a bend or constriction
- the traverse plane should be located such that the effect of leakage between the fan and the plane is minimized
- the location of the traverse plane on the inlet side of the fan should be at a distance not less than 1/2 of the fan inlet diameter.

In general, most mine fans are equipped with access holes for fan testing, and these were considered adequate for the purposes of the test.

4.4.1.2 Selection of Measuring Points

Selection of measuring points on a traverse plane were based on the principle of equal area traversing, that is, the cross-sectional area of the duct was divided into equal areas with several sampling points within each area. Figure 11 shows the position of traverse points in a circular air-measurement section for a 5-area, 20-point traverse. Due to the difficulties in conducting pitot tube surveys in the field where conditions cannot be easily controlled, a 20-point traverse was chosen in preference to the 24-point traverse employed during laboratory testing.

4.4.2 Fan Power Input Determination

Typical motor performance data was used to determine the power input to the fan. These data are referred to as typical because a good correlation exists between the measured values and the

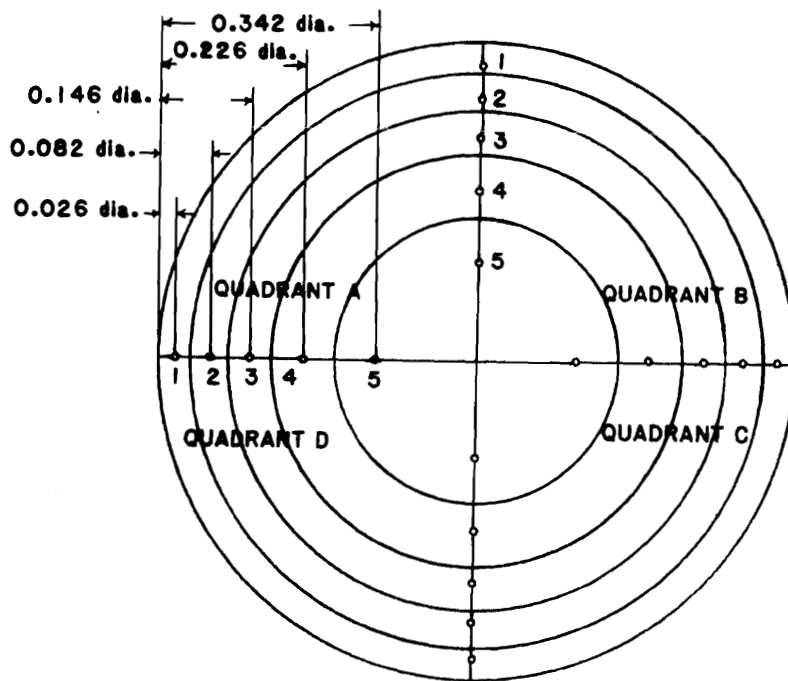

FIGURE 11. - Pitot tube traverse plane.

corresponding values supplied by the fan manufacturer. The field measurements simply consisted of taking current and voltage readings, once with the fan operating in forward and once in reverse. If significant fluctuations were noted, several observations were made and an average value calculated.

4.5 Computations

4.5.1 Air Density

The following equations were used to calculate the density of air:

$$p_p = p_e - p_b \left(\frac{t_d - t_w}{2,700} \right) \quad (1)$$

$$\rho = \frac{1.3257 (p_b - 0.378 p_p)}{t_d + 460}, \quad (2)$$

where, p_p = partial vapor pressure, in. Hg, (inches of mercury, from tables),

ρ = density of air, lb/ft³,

t_w = wet-bulb temperature, °F,

t_d = dry-bulb temperature, °F,

p_b = barometric pressure, in. Hg,

and p_e = saturated vapor pressure at t_w , in. Hg.

Alternatively, special charts are available to determine the approximate value of air density based on t_w , t_d and p_b values obtained in the field.

4.5.2 Conversion Calculations

The following formulas were applied to convert the field results to the speed and density conditions of the fan performance ratings:

$$P_{s_c} = P_s \left(\frac{N_c}{N} \right)^2 \frac{\rho_c}{\rho}, \quad (3)$$

$$P_{v_c} = P_v \left(\frac{N_c}{N} \right)^2 \frac{\rho_c}{\rho}, \quad (4)$$

$$P_{t_c} = P_t \left(\frac{N_c}{N} \right)^2 \frac{\rho_c}{\rho}, \quad (5)$$

where, P_s = fan static pressure, in. W.G. (inches of water gauge),
 P_v = fan velocity pressure, in. W.G.,
 P_t = fan total pressure, in. W.G.,
 N = fan speed, rpm,
 ρ = air density, lb/ft³,

and subscript c designating the value of the parameters after being converted to specified conditions.

4.5.3 Fan Quantity

The average velocity at the plane of traverse is given by:

$$V_c = 1,098 \sqrt{P_{v_c} / \rho_o} \quad , \quad (6)$$

where, V_c = average velocity, fpm,
 P_{v_c} = fan velocity pressure converted to specified conditions, in. W.G.,

and ρ_o = standard air density at sea level and 70°F, lb/ft³.

The flow rate is simply:

$$Q = V_c \times A, \quad (7)$$

where, Q = fan quantity, cfm,
 A = effective area, ft²,

and V_c = average velocity, fpm.

The flow capacities were determined for a fan operating in the forward mode and in reverse, and the percent reduction of flow rate due to fan reversal was calculated, as follows:

$$\% \text{ reduction in capacity} = \left[1 - \frac{Q_r}{Q_f} \right] \times 100, \quad (8)$$

where, Q_r = fan quantity in reverse, cfm,

and Q_f = normal fan capacity, cfm.

4.5.4 Static Pressure

As shown earlier, the fan static pressure under specified conditions is given by equation 4. The percent reduction in static head due to fan reversal is simply:

$$\% \text{ reduction in head} = \left[1 - \frac{P_{sr}}{P_{sf}} \right] \times 100, \quad (9)$$

where, P_{sr} = converted static head of fan while in reverse, in. W.G.

and P_{sf} = converted static head of fan operating in the forward mode, in. W.G.

5.0 FIELD TESTS

Field tests on seven (7) main mine fans were conducted at three (3) mines located in different parts of the United States. Details of the tests along with the results are provided in the following sections.

5.1. Mine No. 1

The first fan test was performed at a room-and-pillar limestone mine in the Midwest. Auxiliary mine ventilation included two 60,000 cfm (28 m³/s) centrifugal fans operating at low pressure. No air doors or regulators that could affect main fan reverse performance were present. The large open area of the mine and low pressure auxiliary fans suggested little interference with the performance of the main fan.

Mine air was exhausted by an 81-in. (2.1-m) diameter 8112-C Chicago Blower vane-axial fan, having a hub diameter of 27 in. (0.7 m), mounted vertically over a 15-ft (4.6-m) diameter mine shaft. A schematic of the fan installation is shown in Figure 12.

5.1.1 Test 1

5.1.1.1 Test Conditions

Due to limited accessibility and absence of ductwork, only one pitot tube traverse plane was available. Very little air turbulence was detected at this plane, possibly due to the absence of elbows, straightening vanes, or offsets. Fan reversal was accomplished by simply reversing the electrical connections leading to the fan motor.

5.1.1.2 Test Results

Performance comparison data for forward and reverse fan operation is listed in Table 2. The operating point in the blowing, or reverse mode, was at a considerably lower volume and static pressure, compared to forward performance. Air quantity in reverse was 55 percent of the capacity in the forward mode, at 36 percent of the static pressure.

This fan was of a different manufacture compared to those tested during the laboratory phase, suggesting that blade design was probably based on a different philosophy. Hub to tip ratio was also higher than the laboratory fans, having a value of 0.33. It was assumed that the blade angle was that listed on the nameplate, 17 degrees (0.3 rad), as access to the blades was not possible.

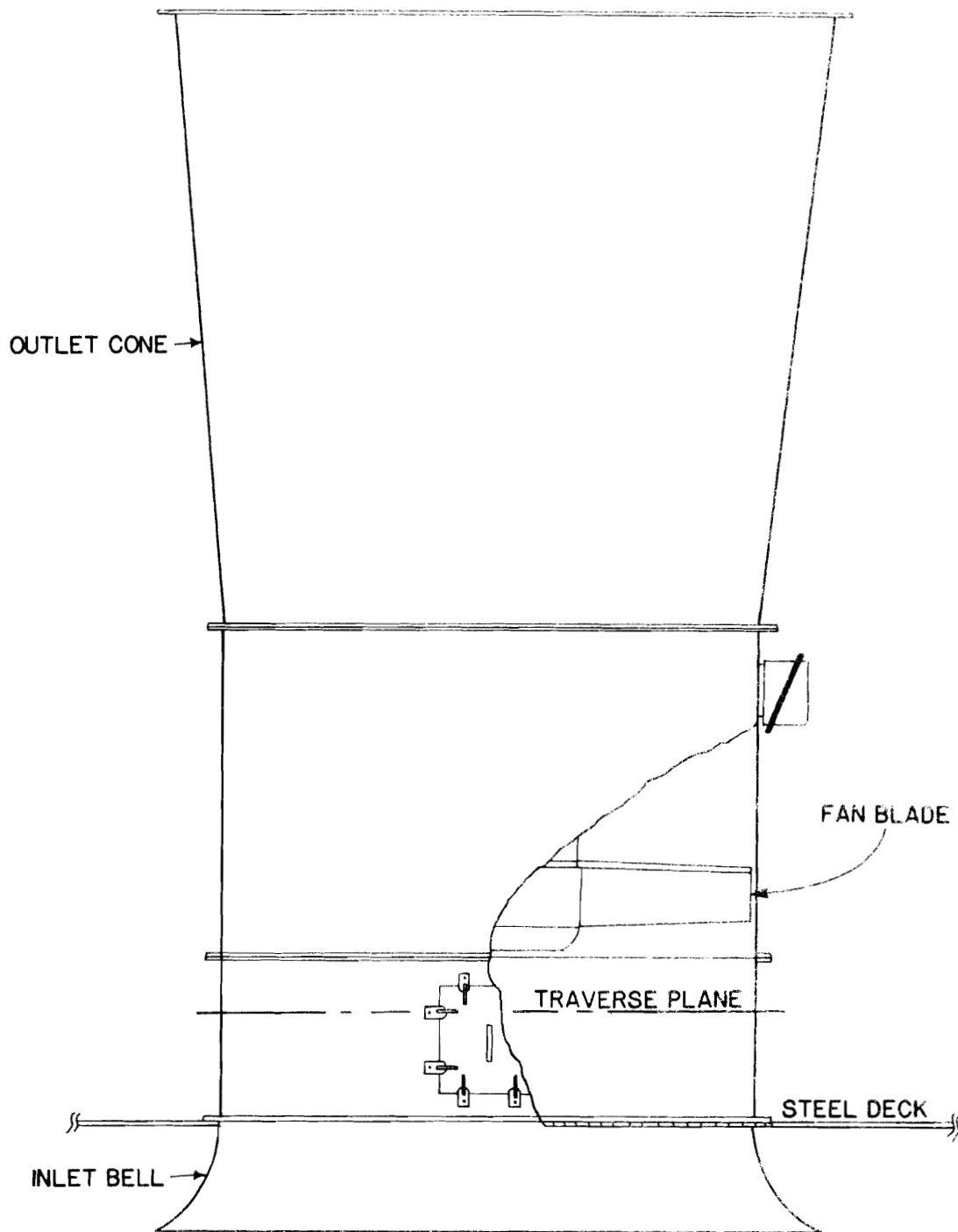

FIGURE 12. - Fan installation at Mine No. 1.

TABLE 2. - Performance comparison for fan 1

<u>Parameter</u>	<u>Forward</u>	<u>Reverse</u>
Volume, cfm (m ³ /s)	227,242 (107)	125,068 (59)
Static Pressure, in. W.G. (Pa)	-3.75 (-933)	1.36 (338)
Total Pressure, in. W.G. (Pa)	-0.57 (-142)	2.32 (577)
Velocity Pressure, in. W.G. (Pa)	3.18 (791)	0.96 (239)
Current, amps	151	127

5.2 Mine No. 2

Tests on four (4) main mine fans were performed at a room-and-pillar copper mine in the Midwest. The mine was fairly extensive and consisted of five (5) intake shafts, one (1) intake portal, and four (4) exhaust shafts. The relative positions of the intake and exhaust shafts and the layout of ventilation stoppings are shown schematically in Figure 13.

Each exhaust shaft was equipped with a M96-50D Joy Axivane fan, rated at 900 RPM and 700 hp. These were 96-in. (2.4-m) diameter vane-axial fans, with 50-in. (1.3-m) hub diameters, mounted horizontally and connected to 40-ft (12.2-m) long evases. Figure 14 shows the essential features of the fan installation along with the locations of the pitot tube traverse planes.

5.2.1 Test 2

5.2.1.1 Test Conditions

This test was conducted on fan 2, the location of which is shown in Figure 13. The traverse planes were located on either side of the fan blades. Minimal air turbulence was detected at the traverse planes.

Testing this fan in the exhaust mode was done with the other three (3) fans also operating in the exhaust mode. During reverse testing, fan 5 was reversed, while fans 3 and 4 were in the normal mode. The air damper doors within the fan housing and the underground air doors were kept open by means of bolts during reversal. This test scheme was considered by mine personnel to represent emergency action for existing mining conditions.

5.2.1.2 Test Results

Performance comparison data for forward and reverse fan operation are listed in Table 3. As expected, a drop in both quantity and static pressure was noted following reversal. Volume of air handled decreased to 39 percent, while static pressure was only 11 percent of the forward value. The blade angle for this fan was found to be 37.5 degrees (0.65 rad), and the measured fan rpm was 920.

5.2.2 Test 3

5.2.2.1 Test Conditions

This test was conducted on fan 3. Forward testing was performed with all fans operating in the normal mode. During reverse testing, fan 4 was reversed, fan 2 was operating in the normal mode, and fan 5 was inoperative due to mechanical difficulty. This test scheme was considered by mine personnel to represent emergency action for existing mining conditions.

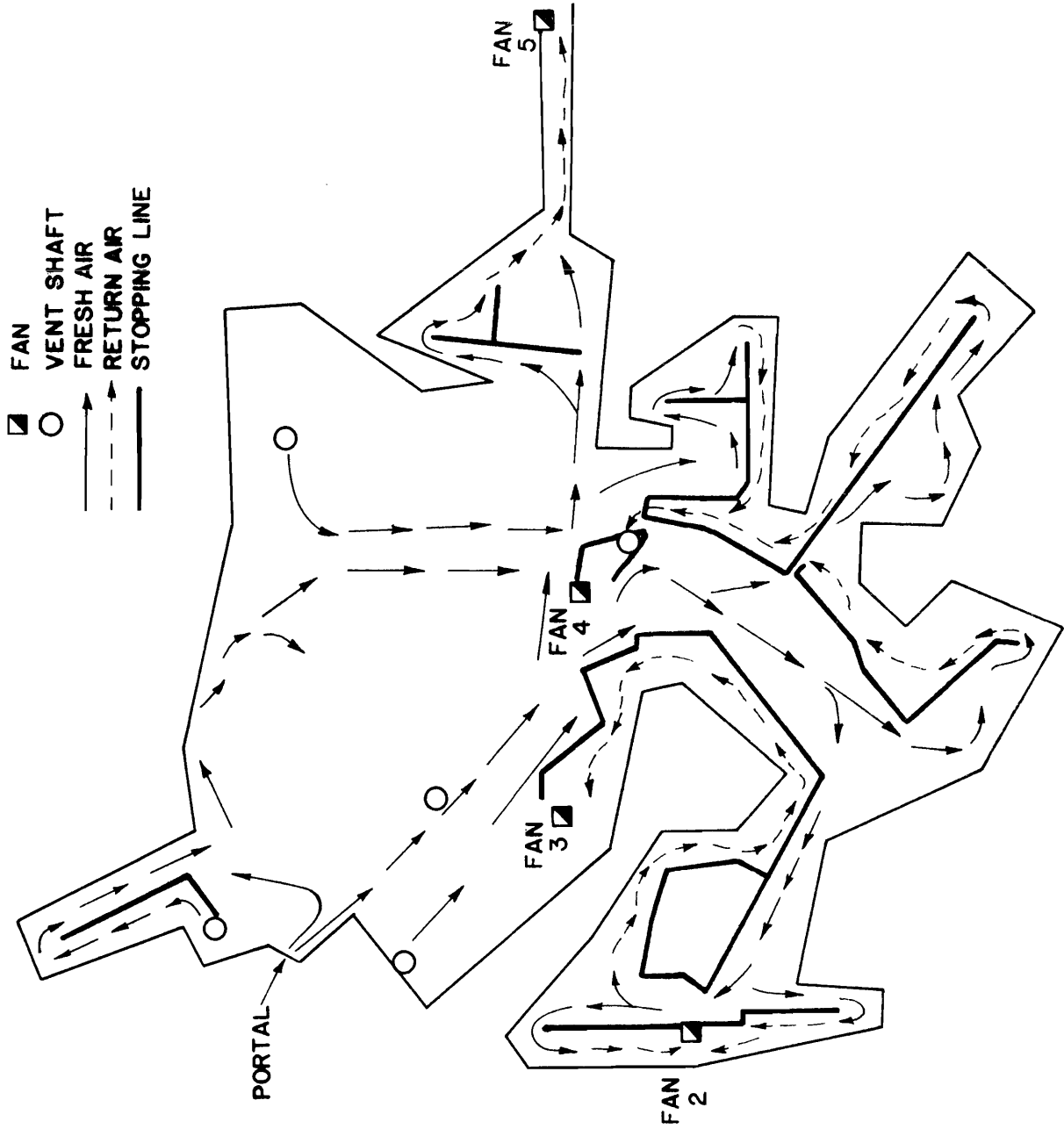

FIGURE 13.- General ventilation arrangement, Mine 2.

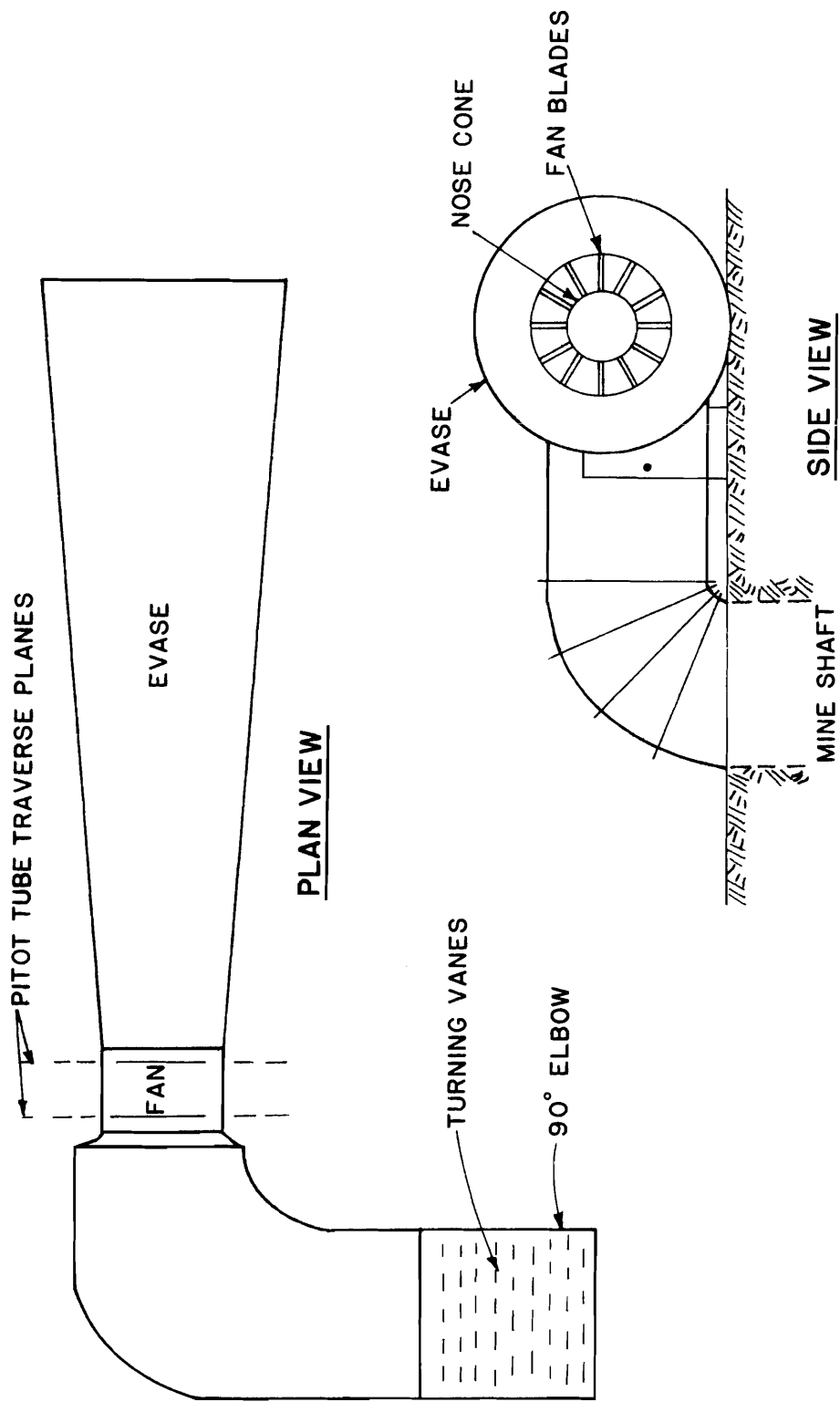

FIGURE 14. - Schematic of fan installations in Mine 2.

TABLE 3. - Performance comparison for fan 2

<u>Parameter</u>	<u>Forward</u>	<u>Reverse</u>
Volume, cfm (m ³ /s)	455,196(215)	177,088(84)
Static Pressure, in. W.G. (Pa)	-16.44 (-4091)	-1.80 (-448)
Total Pressure, in. W.G. (Pa)	-7.85 (-1953)	-0.51 (-127)
Velocity Pressure, in. W.G. (Pa)	8.59 (2138)	1.29 (321)
Current, amps	86	47

5.2.2.2 Test Results

Performance comparison data for forward and reverse fan operation are listed in Table 4. Air quantity in reverse was 37 percent of that in the forward mode and at 9 percent of the static pressure. The blade angle was 36 degrees (0.63 rad) and fan speed was 920 rpm.

5.2.3 Test 4

5.2.3.1 Test Conditions

This test was conducted on fan 4. During fan testing in the exhaust mode, the other three exhaust fans were also operating in the exhaust mode. During reverse testing, fan 3 was reversed. Fan 2 was in the normal operating mode, and fan 5 was inoperative due to mechanical difficulty. This test scheme was considered by mine personnel to represent an emergency action for existing mining conditions.

5.2.3.2 Test Results

The performance comparison between forward and reverse flows is presented in Table 5. Reverse air quantity was 35.5 percent of the capacity in the forward mode, while the static pressure was about 9 percent of the forward value. The blade angle of the fan was determined to be 39 degrees (0.7 rad) and fan rpm was 920.

5.2.4 Test 5

5.2.4.1 Test Conditions

This test was performed on fan 5. During fan testing, all fans were operating in the normal mode. During reverse testing, fan 2 was reversed, while fans 3 and 4 operated in the exhaust mode. This test scheme was considered by mine personnel to represent an emergency action for existing mining conditions.

5.2.4.2 Test Results

The comparison between forward and reverse performance is listed in Table 6. Reverse air quantity was found to be about 40 percent of the quantity in the forward mode, while the static pressure developed was about 14 percent of the forward value. The blade angle was found to be 37 degrees (0.65 rad) and fan speed was 920 rpm.

5.3 Mine No. 3

Tests of two main mine fans, placed in parallel, were conducted at an oil shale operation in the western United States. The mine operated on three levels. The main access drifts at each level branched from an 8-ft (2.4-m) diameter circular shaft. Each of these

TABLE 4. - Performance comparison for fan 3

<u>Parameter</u>	<u>Forward</u>	<u>Reverse</u>
Volume, cfm (m ³ /s)	480,868 (227)	177,139 (84)
Static Pressure, in. W.G. (Pa)	-16.05 (-3994)	-1.44 (-358)
Total Pressure, in. W.G. (Pa)	-6.47 (-1610)	-0.14 (-35)
Velocity Pressure, in. W.G. (Pa)	9.58 (2384)	1.30 (323)
Current, amps	91	78

TABLE 5. - Performance comparison for fan 4

<u>Parameter</u>	<u>Forward</u>	<u>Reverse</u>
Volume, cfm (m ³ /s)	516,446 (244)	183,169 (86)
Static Pressure, in. W.G. (Pa)	-16.70 (-4156)	-1.53 (-381)
Total Pressure, in. W.G. (Pa)	-5.65 (-1406)	-0.14 (-35)
Velocity Pressure, in. W.G. (Pa)	11.05 (2750)	1.39 (346)
Current, amps	87	74

TABLE 6. - Performance comparison for fan 5

<u>Parameter</u>	<u>Forward</u>	<u>Reverse</u>
Volume, cfm (m ³ /s)	458,296 (216)	183,326 (87)
Static Pressure, in. W.G. (Pa)	-15.08 (-3753)	-2.14 (-532)
Total Pressure, in. W.G. (Pa)	-6.34 (-1578)	-0.76 (-189)
Velocity Pressure, in. W.G. (Pa)	8.74 (2175)	1.38 (343)
Current, amps	96	82

drifts were about 25-ft (7.6-m) high and 25-ft (7.6-m) wide and led to modified room-and-pillar working sections. The ventilating air at the two lower levels were regulated by free hanging brattice partially blocking the airways, while the upper level access drift was completely open. An auxiliary fan operated at the lower level during fan testing; however, the large cross-sectional area of airways suggested little interference with main fan performance.

Mine air was exhausted by two 79-in. (2-m) diameter, 200 hp AMF 2000-80-10 Spendrup vane-axial fans, each having a hub diameter of 31 in. (0.8 m), horizontally mounted in a Y-connection off the shaft. Figure 15 shows the installation, which is heavily insulated to prevent ice build-up.

5.3.1 Tests 6 and 7

5.3.1.1 Test Conditions

Due to limited accessibility and absence of substantial ductwork, only one pitot tube traverse plane was available. This plane was located at the junction of the fan housing and the evase. Some turbulence at the traverse plane was noticed, probably due to straightening vanes or fan motor supports. Fan reversal was accomplished by simply reversing the electrical connections to the fan motor.

5.3.1.2 Test Results

Performance comparison data for forward and reverse fan operation are listed in Tables 7 and 8. The static and total pressure readings obtained during forward fan testing at this mine were rather erratic and, contrary to expectations, the sum of static and velocity pressures at several measurement points did not equal the total pressure. This was judged to be caused by an unfavorable pitot traverse location. The velocity pressure readings, on the other hand, appeared less affected by the location and were fairly consistent.

In order to eliminate the discrepancies in the pressure readings, the expected fan pressure at the inby side of the fan in the forward mode was estimated on the basis of the mine characteristic curve and the measured velocity pressure. The mine resistance, R , was calculated from the operating point data for the mine. The mine characteristic curve was plotted for different values of air quantity, Q , as shown in Figure 16, using the following relationship:

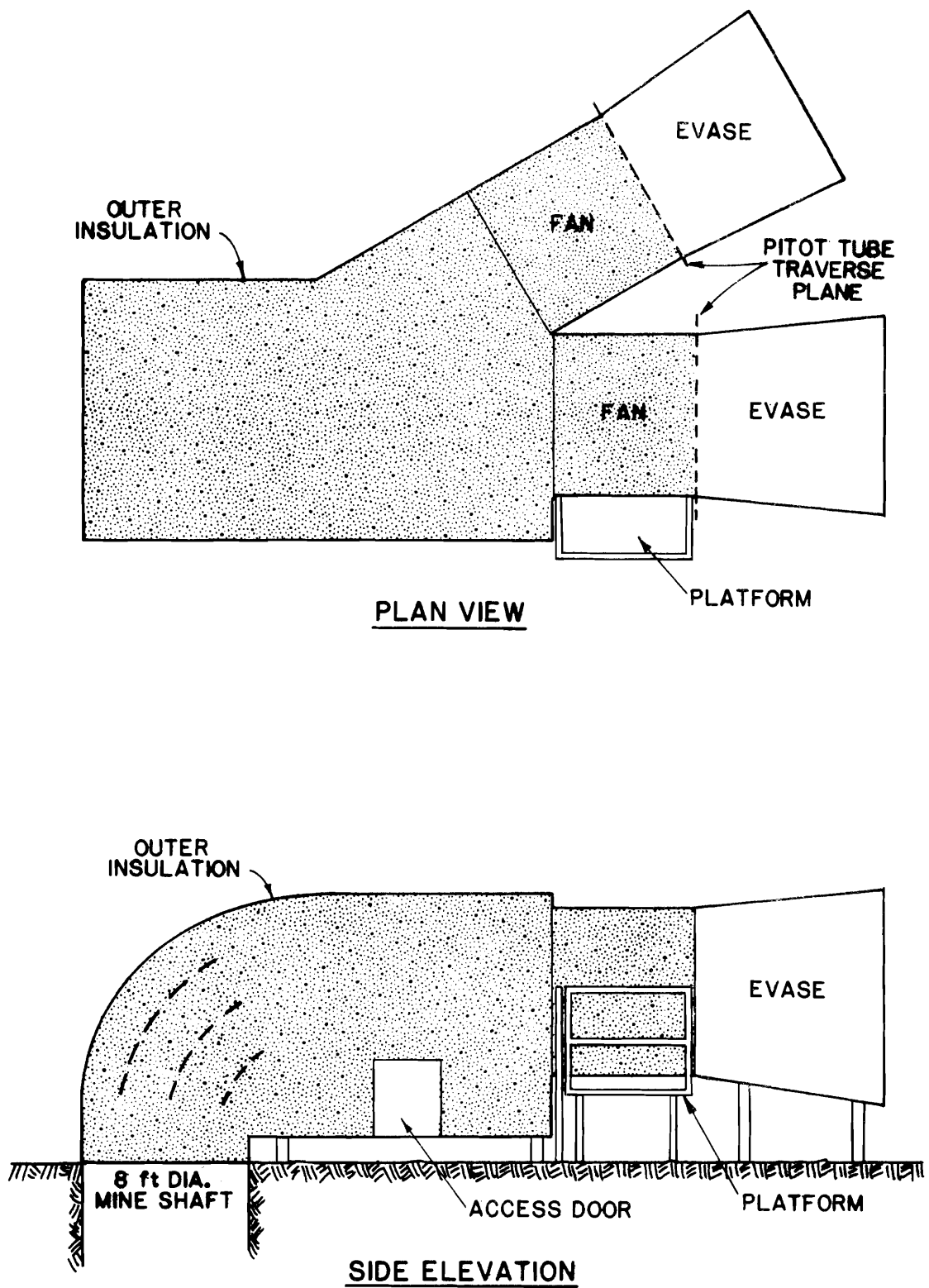

FIGURE 15. - Schematic of fan installations at Mine No. 3.

TABLE 7. - Performance comparison for fan 6

<u>Parameter</u>	<u>Forward</u>	<u>Reverse</u>
Volume, cfm (m ³ /sec)	113,130 (53)	57,072 (27)
Static pressure, in. W.G. (Pa)	-2.33 (-580)	-0.55 (-137)
Total Pressure, in. W.G. (Pa)	-1.50 (-373)	-0.36 (-90)
Velocity Pressure, in. W.G. (Pa)	0.83 (207)	0.19 (47)
Current, amps	144	141

TABLE 8. - Performance comparison for fan 7

<u>Parameter</u>	<u>Forward</u>	<u>Reverse</u>
Volume, cfm (m ³ /sec)	127,463 (60)	54,983 (26)
Static pressure, in. W.G. (Pa)	-2.99 (-7.44)	-0.67 (-167)
Total Pressure, in. W.G. (Pa)	-1.93 (-480)	-0.49 (-122)
Velocity Pressure, in. W.G. (Pa)	1.06 (264)	0.18 (45)
Current, amps	150	144

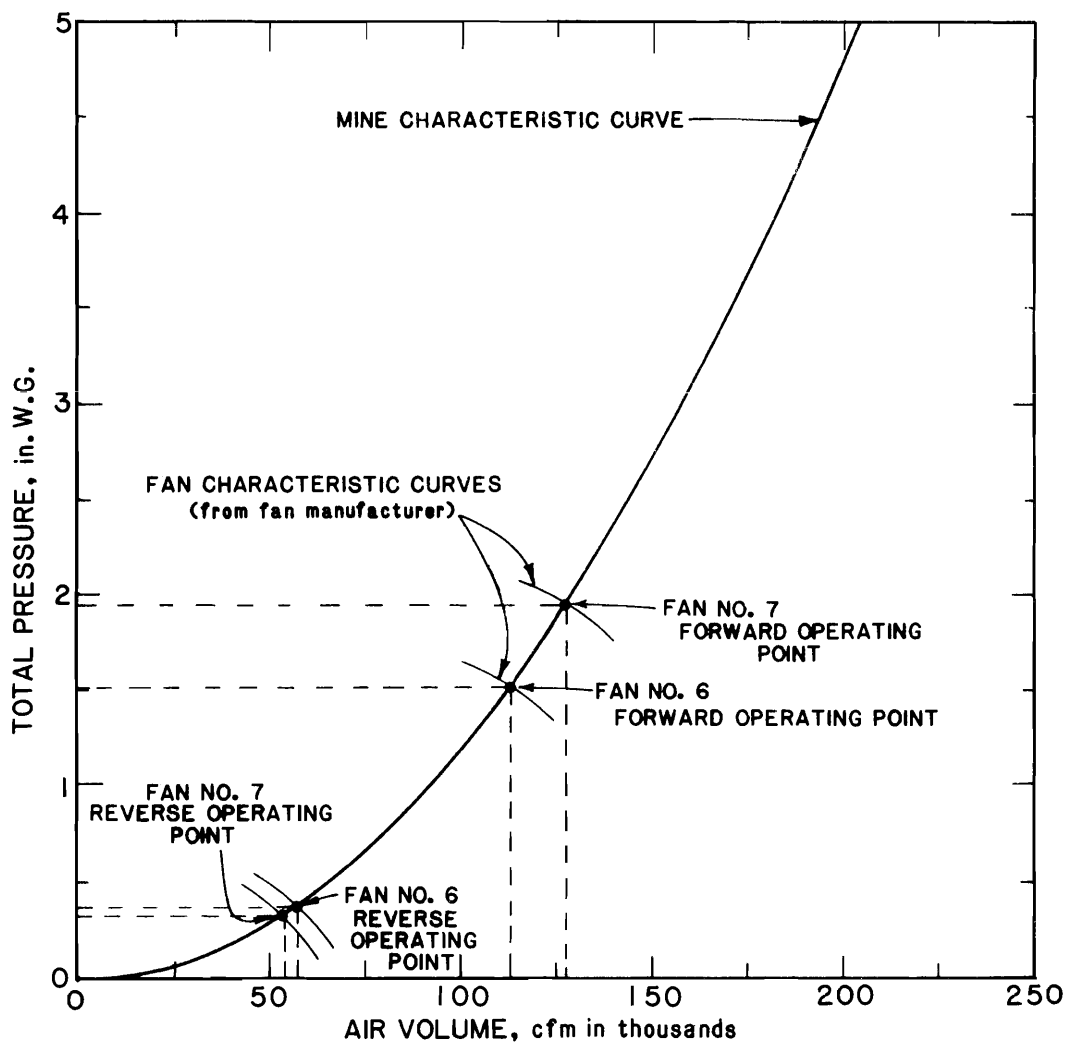

FIGURE 16. - Computation of total pressure from characteristic curves.

$$P = RQ^2,$$

where, P = the total pressure.

The measured forward quantity for each fan was entered on the Q-axis, intercepting the mine characteristic curve. The corresponding total pressures were read. The static pressures were then calculated using the estimated value of total pressures and observed velocity pressures.

In order to verify the validity of this approach, the observed reverse quantities were also entered on the Q-axis and the corresponding total pressures were compared to measured data. The calculated values were found to be reasonably close to observed data. It should be emphasized, however, that the calculation of mine resistance was based on anticipated fan duty for a specific fan and blade angle and does not necessarily reflect the actual resistance of the mine airways. The results obtained through this approach should, therefore, be considered merely as rough estimates of the actual conditions. The data did not accurately show the exhaust performance values, however, the data did allow differences between forward and reverse performance to be identified.

The calculated static pressures appear in Table 9. The fan 6 quantity in the reverse mode is 50.5 percent of that in the forward mode, at 23.6 percent of the static pressure in the forward mode. The prediction would be $(0.505)^2$ or 25.5 percent. Fan 7 gave 43.1 percent of forward flow when reversed, at 22.1 percent of the static pressure. The predicted pressure would be $(0.431)^2$ or 18.6 percent. Therefore, these results are in good agreement with earlier data.

These fans were of a different manufacture than those tested in the laboratory, suggesting that blade design philosophy was probably different. Hub to tip ratio was also higher than the laboratory fans, having a value of about 0.39. Blade tip angles were measured at 12 degrees (0.21 rad) and 15 degrees (0.76 rad) for fans 6 and 7, respectively.

5.4 Summary of Field Results

Table 9 provides a performance comparison summary for all the fans tested in the field (absolute values of static pressures are shown). Based on these results, Figure 17 was plotted to illustrate the relationship between reverse performance, the blade angle, and hub to tip ratio of vane axial fans. The laboratory data are also included in this plot to demonstrate the correlation between laboratory and field results.

It is evident from Figure 17 that the results of fan testing at Mine 2 are in good agreement with the laboratory results. The field

TABLE 9. - Field test data summary

Test	Volume		R/F*, %	Static Pressure		Blade Angle, degrees (rad)	Hub to Tip Ratio
	Forward, cfm (m ³ /s)	Reverse, cfm (m ³ /s)		Forward in. W.C. (Pa)	Reverse in. W.C. (Pa)		
1	227,242 (107)	125,068 (59)	55.1	3.75 (933)	1.36 (338)	17.0 (0.30)	0.33
2	455,196 (215)	177,088 (84)	38.9	16.44 (4091)	1.80 (448)	37.5 (0.65)	0.52
3	480,868 (227)	177,139 (84)	36.8	16.05 (3994)	1.44 (358)	36.0 (0.63)	0.52
4	516,446 (244)	183,169 (86)	35.5	16.70 (4156)	1.53 (381)	39.0 (0.70)	0.52
5	458,296 (216)	183,326 (87)	40.0	15.08 (3753)	2.14 (532)	37.0 (0.65)	0.52
6	113,130 (53)	57,072 (27)	50.5	2.33 (580)	0.55 (137)	12.0 (0.21)	0.39
7	127,463 (60)	54,983 (26)	43.1	2.99 (744)	0.67 (167)	15.0 (0.26)	0.39

* Reverse performance as a percentage of forward performance

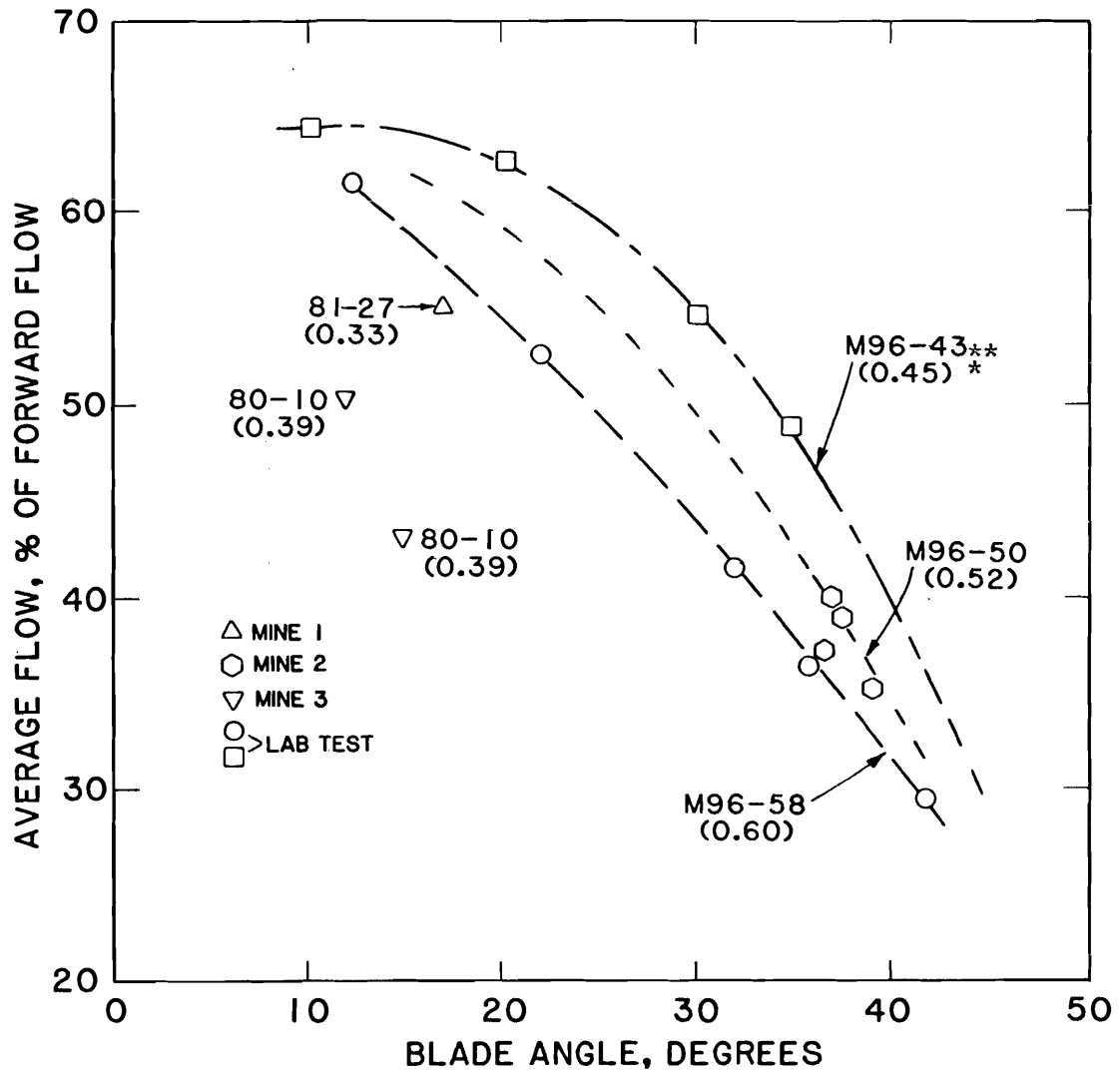

FIGURE 17. - Fan average performance versus blade angle.

*Figures in parentheses refer to hub to tip ratios
 **Fan model number

data are not as consistent as the laboratory data, due to the inherent inaccuracies in field testing arising from excessive blade wear, interaction between fans, and air turbulence.

The data points from Tests 1, 6 and 7 however, do not exhibit any apparent correlation with the other test results. There are two possible explanations for these discrepancies. First, fan interaction during tests 6 and 7 could have affected results in that the fan junction duct was very close to the fan housing. This could permit one fan to interfere with the static pressure produced by the other. Second, fans 1, 6 and 7 were of a different manufacture compared to the laboratory and Mine No. 2 fans, suggesting perhaps that the blade design was based on a different philosophy.

The inverse square relationship between pressure and air quantity obtained during laboratory testing (Section 3.3.3), appeared to hold true for the field results, within reasonable limits of error. The results from Mine No. 2 deviated from this relationship, probably due to interaction between the various fans and the complex ventilation system at this mine.

6.0 GUIDELINES FOR REVERSING FANS

6.1 Data Trends from Present Work

Based on the laboratory and field test results, the following distinct trends are evident:

- for a given hub to tip ratio and blade angle, there appears to be a definite relationship between the reverse fan volume as a percentage of forward volume of a vane-axial fan. This relationship is likely to be different for fans of different manufacturers
- reverse performance of vane-axial fans is inversely related to their blade tip angles
- in the absence of significant interaction from auxiliary fans within a given mine network, the percent of static pressure obtained during reverse operation varies as a square of the change in air volume. This may be expressed as:

$$P_s \propto Q^2,$$

where $P_s = \frac{\text{static pressure, fan reversed}}{\text{static pressure, fan forward}}$,

and $Q = \frac{\text{reverse air quantity}}{\text{forward air quantity}}$.

6.2 Guidelines

When fan reversal at a mine is anticipated, due to an emergency situation or otherwise, the mine operator should consider the effectiveness of fan reversal in correcting that particular situation. The following steps are recommended for this evaluation:

1. Obtain fan data, such as:

- type of fan (manufacturer)
- forward fan quantity
- blade angle (corresponding to blade setting number)
- hub to tip ratio.

2. Based on the above information, and with the help of a reverse performance chart (as shown in Figure 8 obtained from laboratory tests of the fan in reverse) for that fan type, estimate the fan quantity and pressure in reverse.

3. Establish the quantity of air available to different parts of the mine and the overall airflow pattern based on the characteristics of the mine airways.

This will enable the mine operator to evaluate:

- in case of a fire, whether the fire can be isolated
- whether sufficient air would be available to persons in different areas of the mine
- whether gaseous pollutants can be adequately dissipated.

On the basis of such evaluation, the mine operator would be able to effectively and efficiently determine if and how fan reversal should be done.

6.3 Applicability of Guidelines

The limitations of the results of this study should be understood before applying the guidelines to a particular mine. These are:

- in a situation where several fans are operating in close proximity to one another within a ventilation circuit, the effect of their interaction may influence the predictability of the reverse performance of an individual fan. The results of this study should, therefore, be used with caution when fan interaction is anticipated
- due to time and budget limitations, only a limited variety of fan types were tested. The study revealed that fans of different manufacturers had different reverse characteristics, possibly due to the blade design philosophy of each type. Most of the conclusive findings of this study relate to fans made by Joy Manufacturing Company. The applicability of the results, therefore, is limited to Joy fans, or to fans identical to those tested in the field
- due to the nature of the fan installations at most of the field testing sites, ideal pitot tube traverse planes for pressure and flow measurement could not be found. This may have introduced inaccuracies in the field measurements, and could account for some of the discrepancies in the final results.

7.0 CONCLUSIONS AND RECOMMENDATIONS

7.1 Conclusions

The following is a summary of the major conclusions reached from the results of this study:

- the study clearly demonstrates that it is possible to predict reverse performance of vane-axial fans to a reasonable degree of accuracy, based on data obtainable from fan manufacturers
- the reverse performance of vane-axial fans is not a fixed percentage of forward performance, contrary to earlier belief. It generally varies between 30 to 65 percent, depending on fan make, blade angle, and hub to tip ratio. Static pressure during reverse rotation generally is reduced to values between 9 and 42 percent of the forward mode.
- fan laws governing airflow during the forward operation of mine fans appear to be applicable to reverse flow
- the field tests indicated that fan reversal does not have noticeable effect on the structural integrity of the fan and installation. In addition, provided that air doors and dampers (if present) are kept securely fastened during reverse operation, the safety of the mine is not endangered.

7.2 Recommendations for Future Work

The testing of two fans in the laboratory and seven in the field does not provide sufficient data from which to establish definite guidelines. Information from other operating mines that have performed similar tests is necessary to generalize the data trends observed in this study. This collection should include information from small diameter fans and from fans made by many different manufacturers. From this study, it is apparent that fans of different manufacture behave differently when reversed.

It would also be advantageous to test multiple fan installations in various ways to better establish the effect of fan interaction on performance. Another worthwhile area of research is to investigate the effect of fan reversal on airflow in underground airways in order to predict conditions during an emergency.

8.0 APPENDIX A

Fan Performance Curves
Obtained in the Laboratory

TEST PERFORMANCE
 FAN MODEL: M96-43
 JOY AXIVANE MINE FAN
 FAN SPEED: 720 RPM
 AIR DENSITY: 0.075 #/cu ft
 BLADE TIP ANGLE: 10°

REVERSE FLOW IN PERCENT
 OF FORWARD FLOW
 FAN OPERATING ON THE SAME
 SYSTEM WITH REVERSE ROTATION

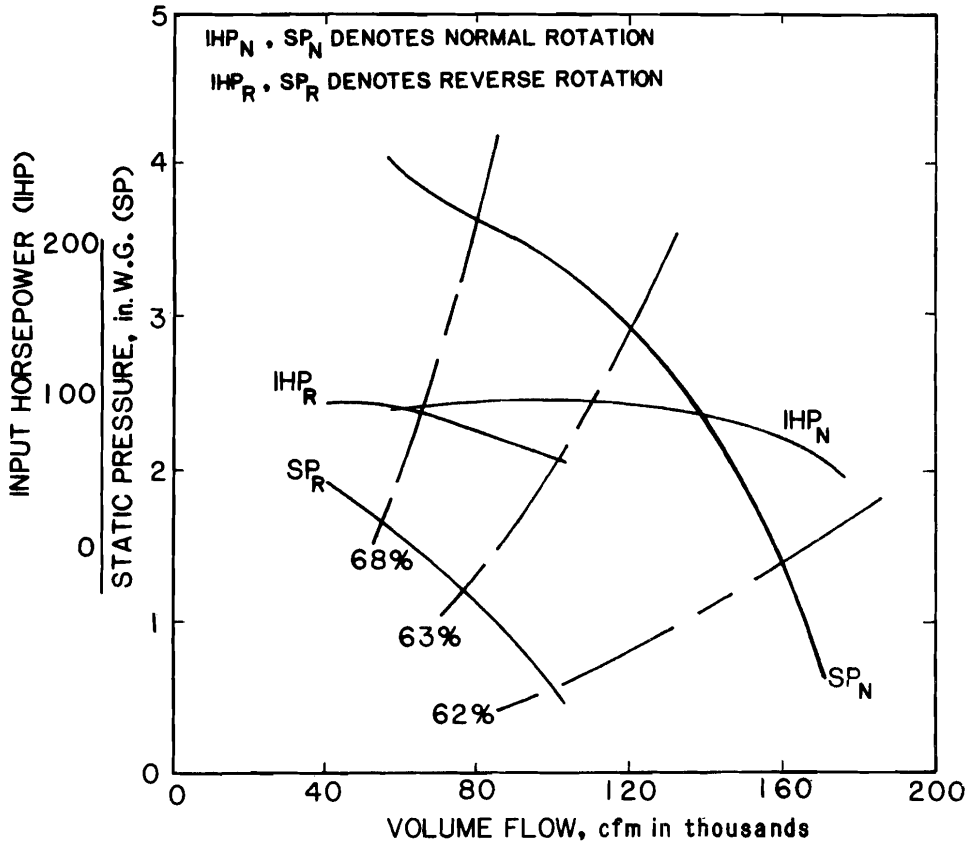

FIGURE A1. - Fan performance with 10° blade angle.

TEST PERFORMANCE
 FAN MODEL: M96- 43
 JOY AXIVANE MINE FAN
 FAN SPEED: 720 RPM
 AIR DENSITY: 0.075 #/cu ft
 BLADE TIP ANGLE: 20°

REVERSE FLOW IN PERCENT
 OF FORWARD FLOW
 FAN OPERATING ON THE SAME
 SYSTEM WITH REVERSE ROTATION

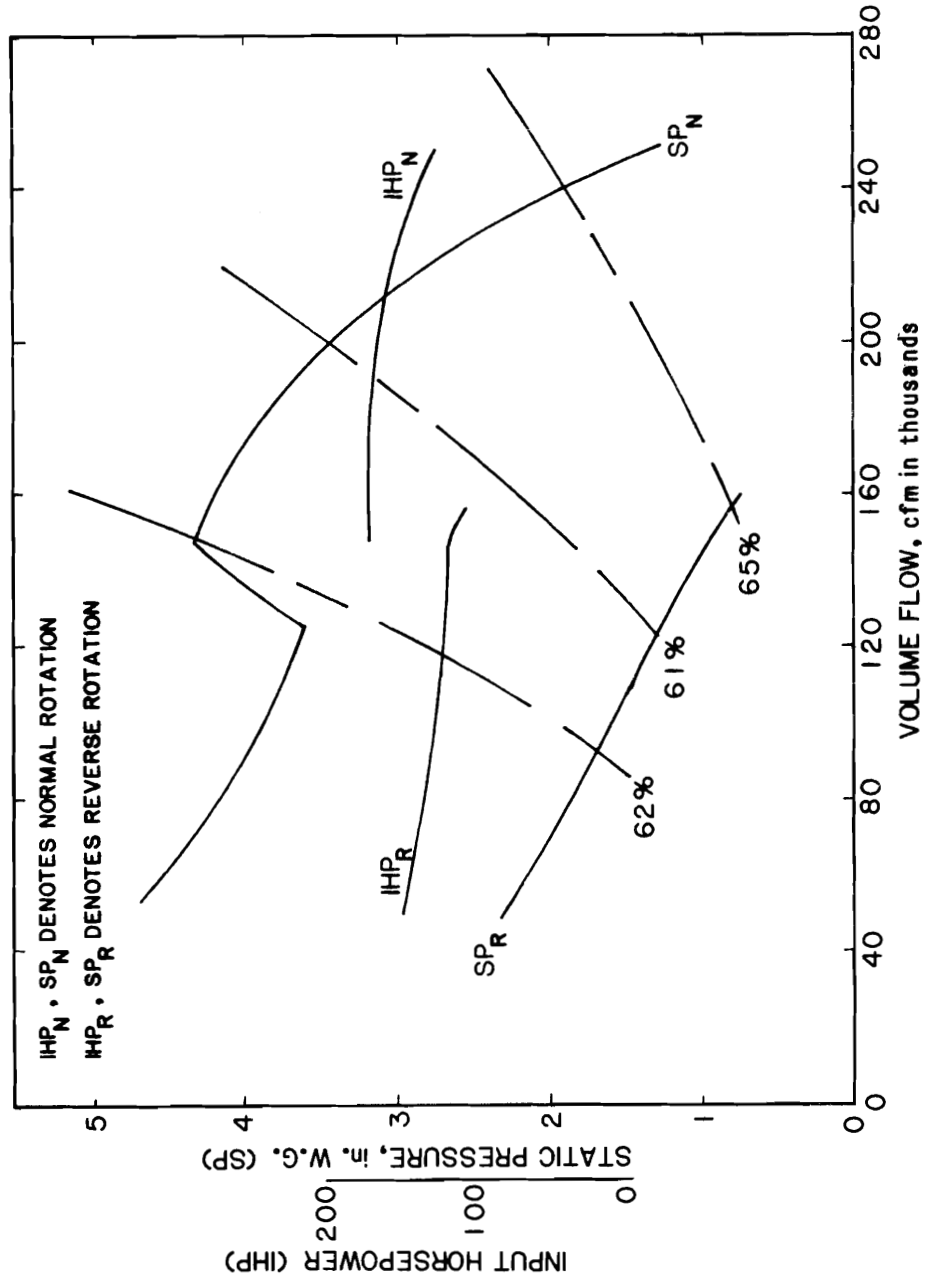

FIGURE A2.- Fan performance with 20° blade angle.

TEST PERFORMANCE
 FAN MODEL: M96-43
 JOY AXIYANE MINE FAN
 FAN SPEED: 720 RPM
 AIR DENSITY: 0.075 #/cu ft
 BLADE TIP ANGLE: 30°

REVERSE FLOW IN PERCENT
 OF FORWARD FLOW
 FAN OPERATING ON THE SAME
 SYSTEM WITH REVERSE ROTATION

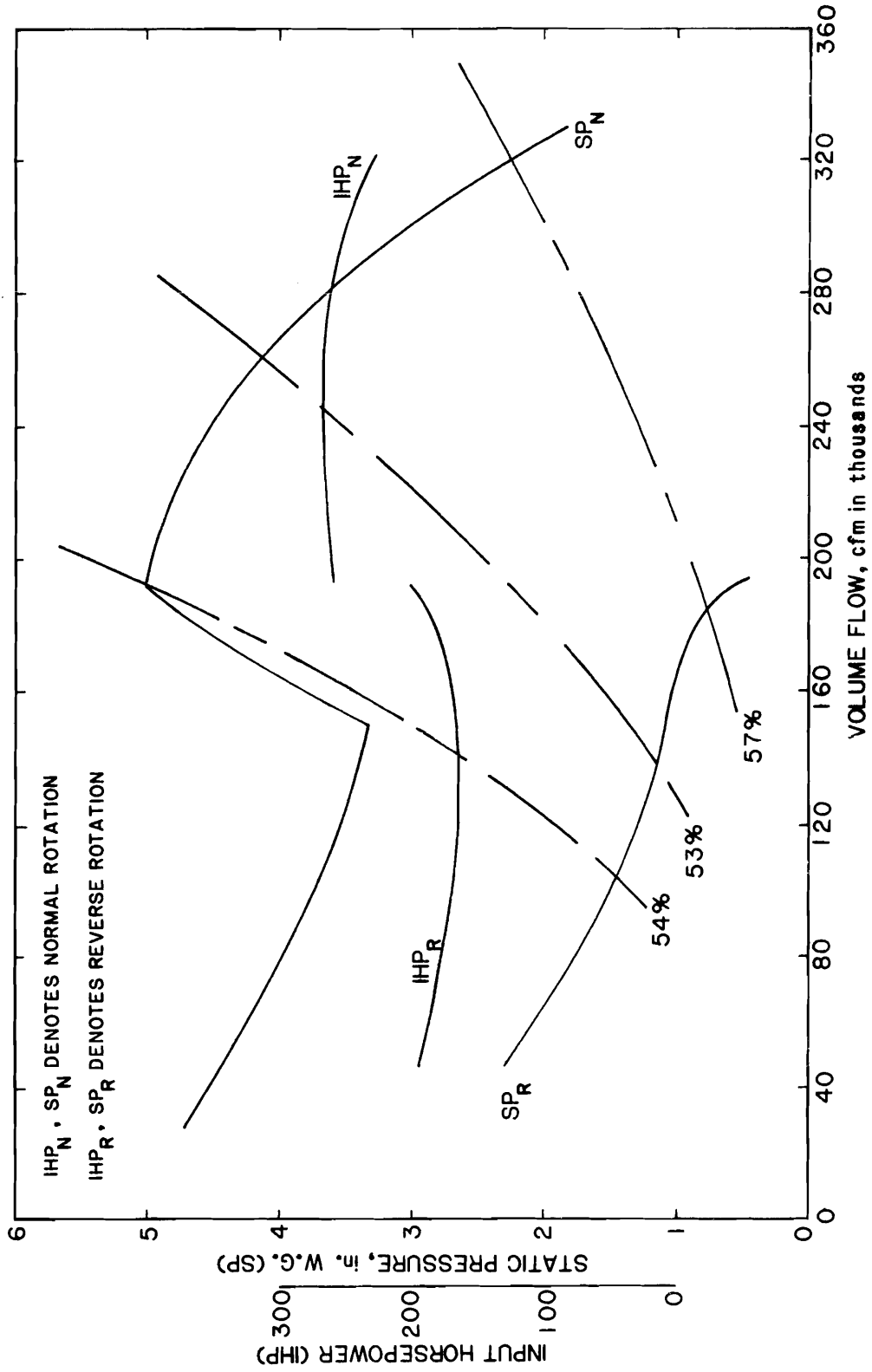

FIGURE A3. - Fan performance with 30° blade angle.

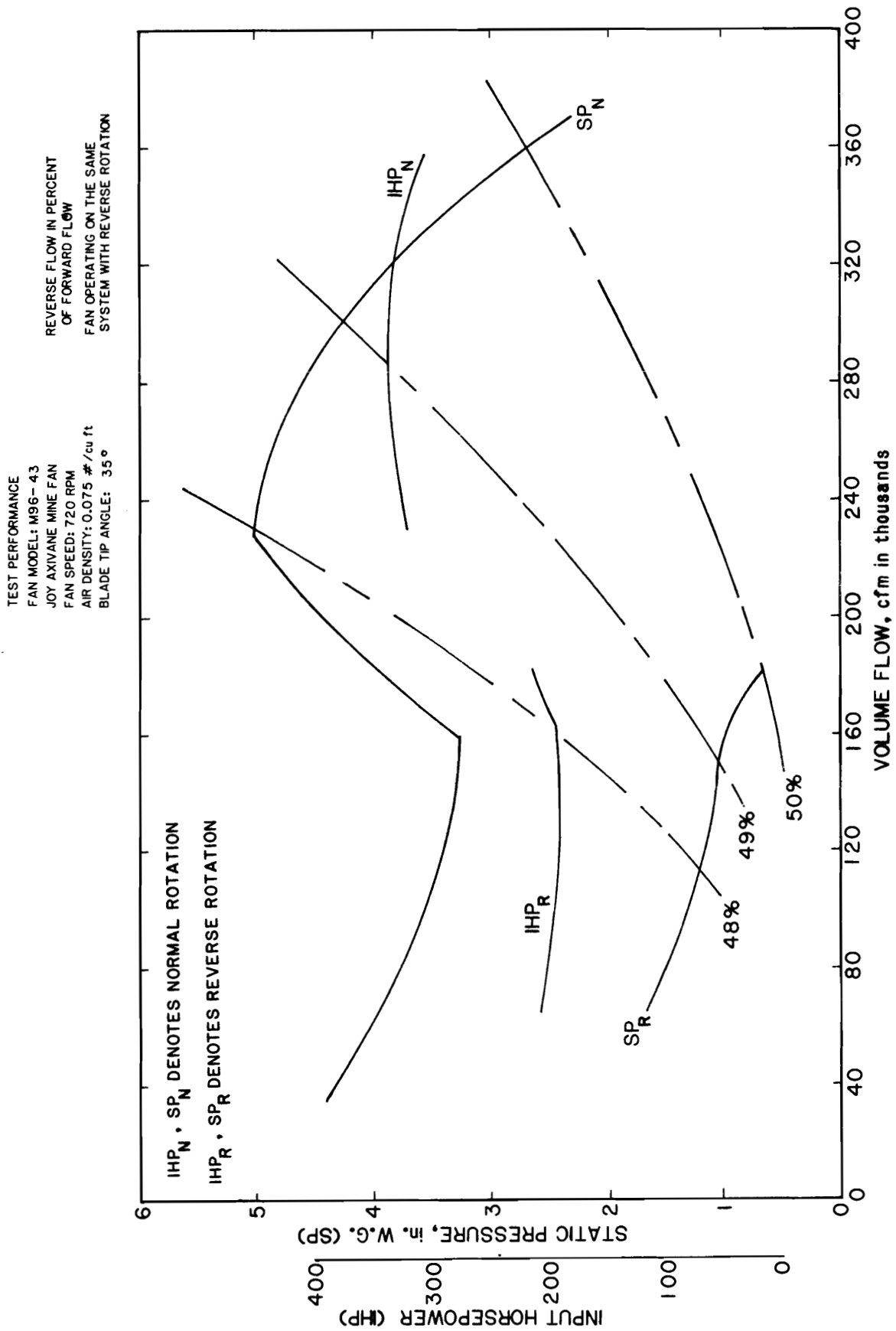

FIGURE A4. - Fan performance with 35° blade angle.

TEST PERFORMANCE
 FAN MODEL: M96-58
 JOY AXVANE MINE FAN
 FAN SPEED: 720 RPM
 AIR DENSITY: 0.075 #/cu ft
 BLADE TIP ANGLE: 12°

REVERSE FLOW IN PERCENT
 OF FORWARD FLOW
 FAN OPERATING ON THE SAME
 SYSTEM WITH REVERSE ROTATION

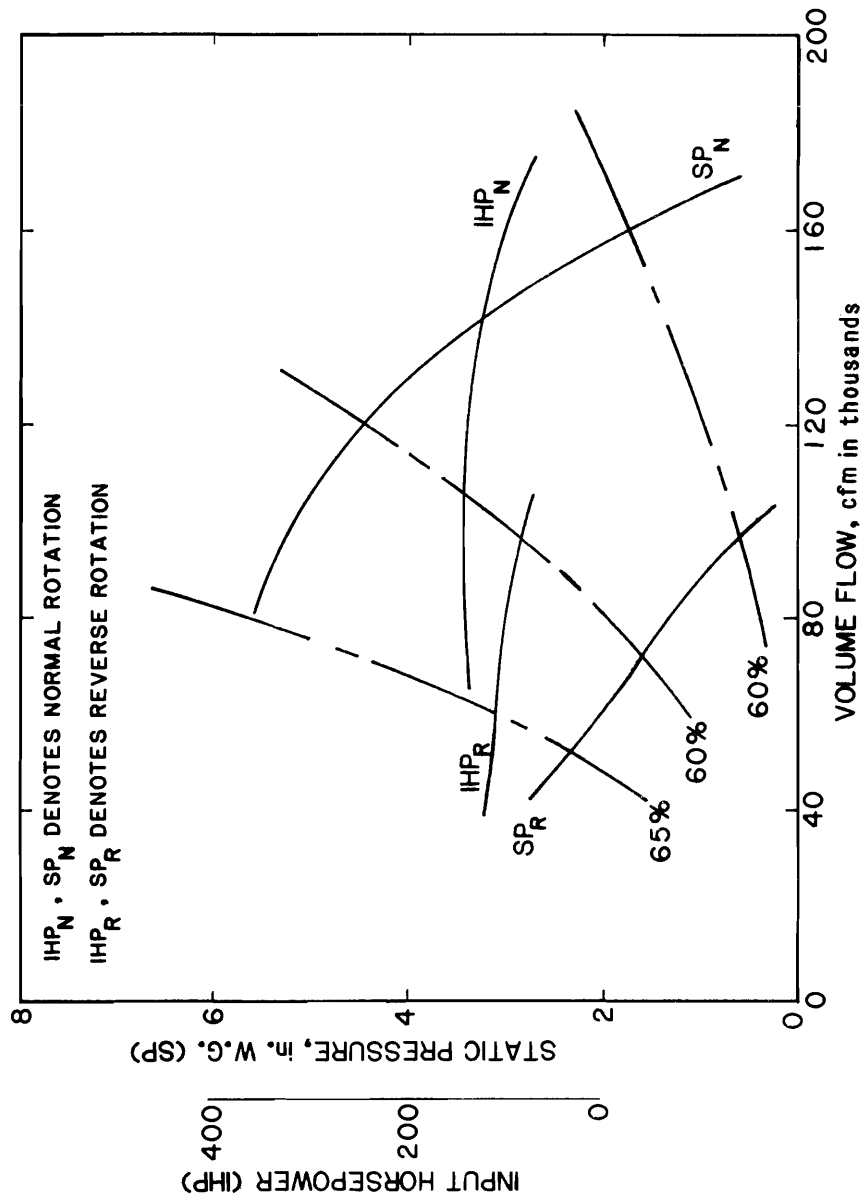

FIGURE A5. - Fan performance with 12° blade angle.

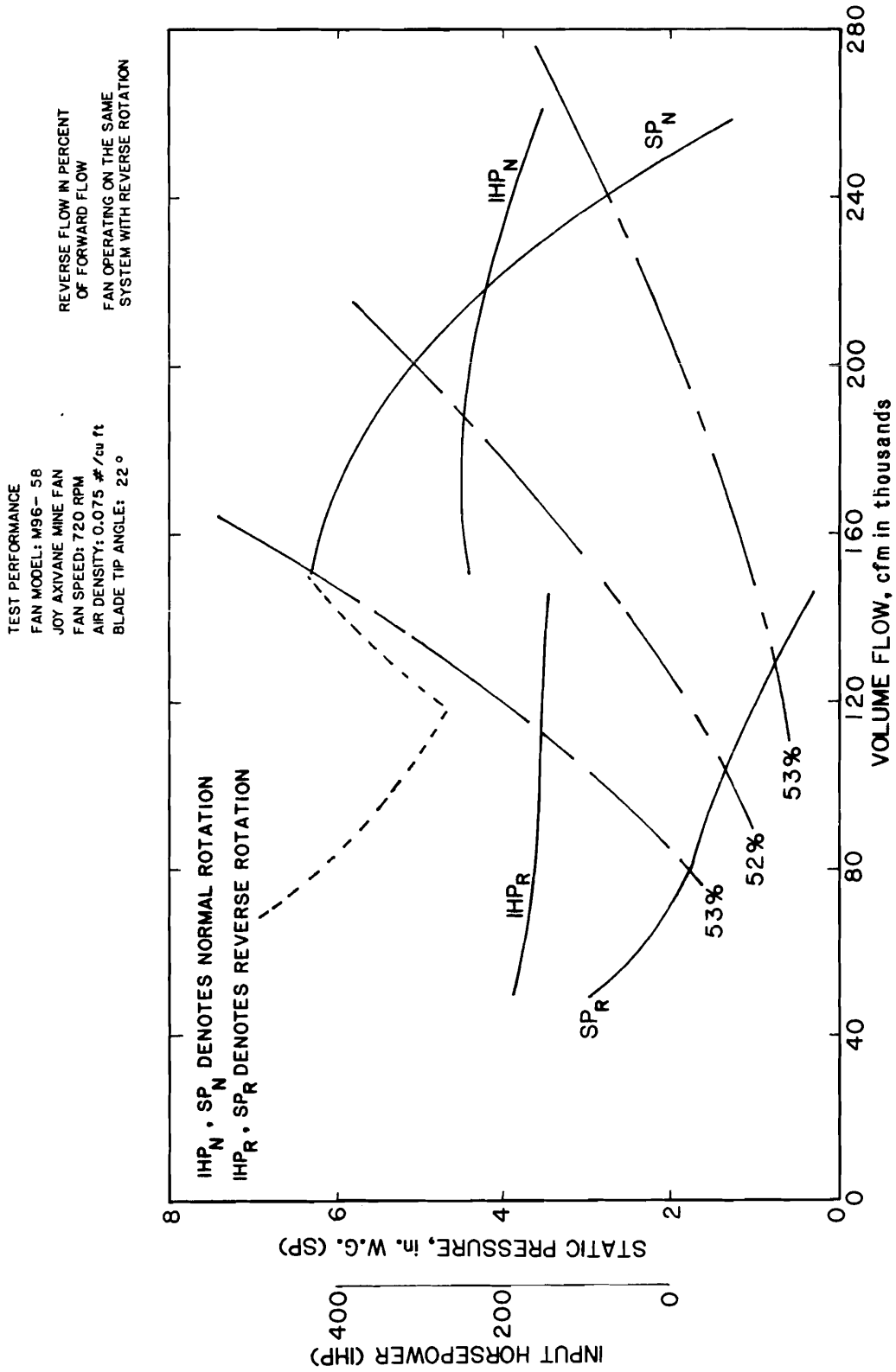

FIGURE A6. - Fan performance with 22° blade angle.

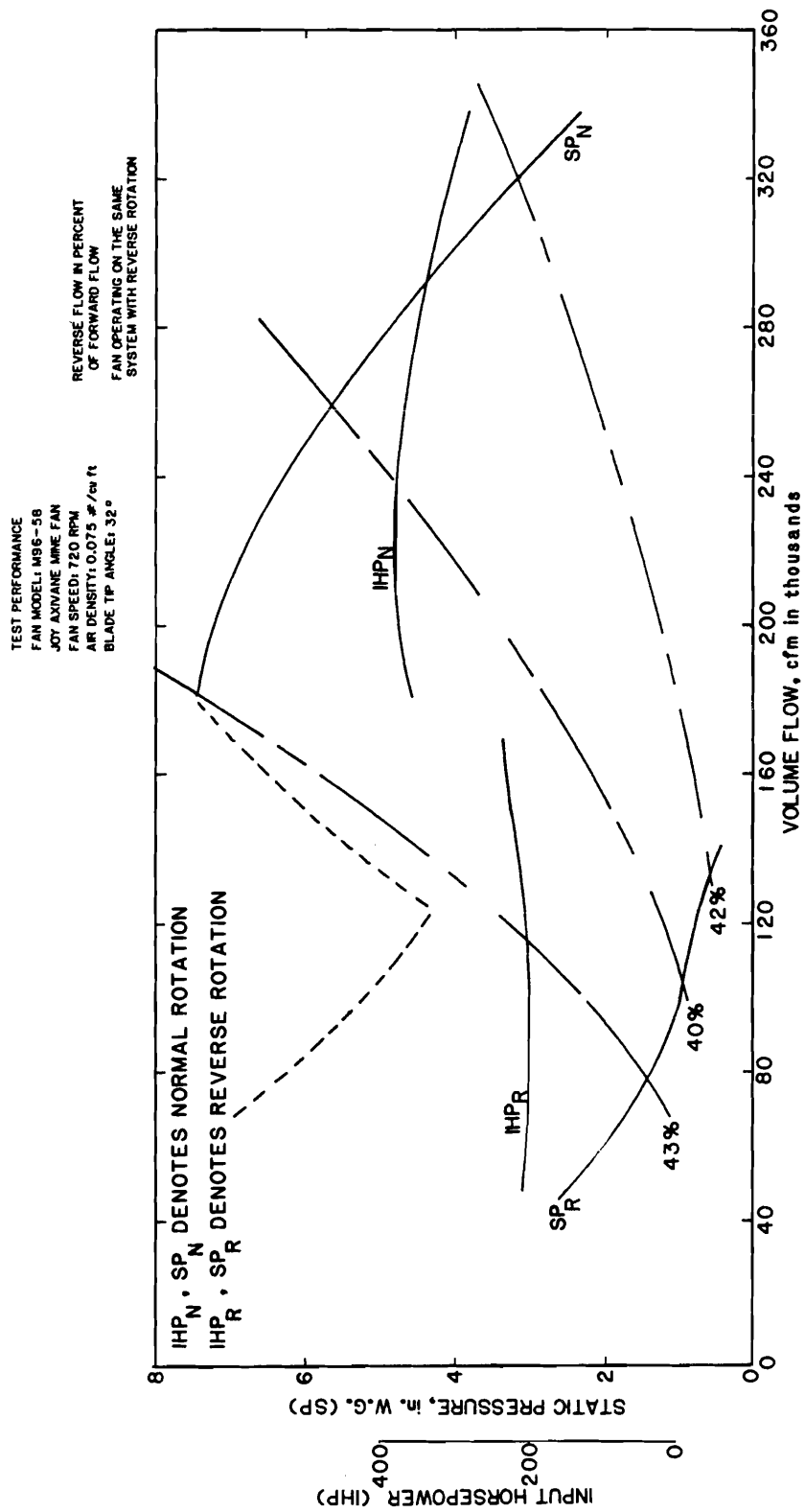

FIGURE A7. - Fan performance with 32° blade angle.

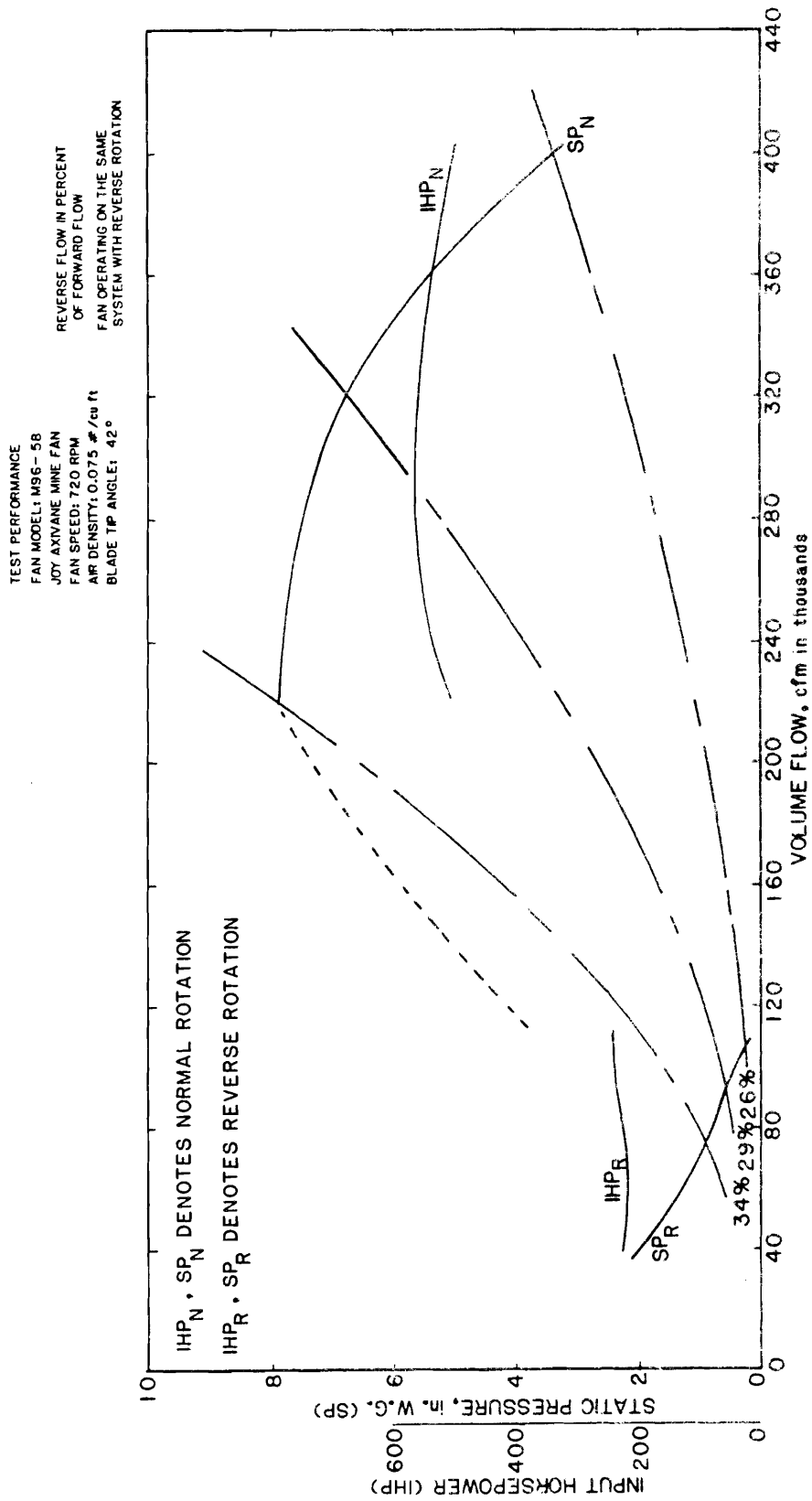

FIGURE A8. - Fan performance with 42° blade angle.