

EFFECTS OF WATER SPRAYS AND SCRUBBER EXHAUST ON FACE METHANE CONCENTRATIONS

Ch.D. Taylor
NIOSH/Pittsburgh Research Laboratory
Pittsburgh, PA

J.A. Zimmer
NIOSH/Pittsburgh Research Laboratory
Pittsburgh, PA

ABSTRACT

Past studies with blowing face ventilation systems have shown that using a machine-mounted scrubber and water sprays can reduced methane levels at the face. The current research was conducted to determine how the sprays and scrubber interact to reduce methane levels, and what spray configurations provide the best face ventilation when used with a scrubber. Testing was conducted in a ventilation test gallery designed to simulate a full-scale mine entry. In the entry, a model mining machine, equipped with a simulated dust scrubber and water spray systems, was located at the face of a 6.1 m (20 ft) box cut. Face ventilation was provided by a blowing curtain located 12.2 m (40 ft) from the face. Methane released from a manifold at the face was measured at six locations near the face to compare the ventilation effectiveness of the spray systems while operating with and without the scrubber. Airflow movement across the face was affected by the spray configuration and scrubber operation. Average face concentrations were lowest when directed sprays were used with the scrubber. Varying the direction of the scrubber exhaust affected face methane levels.

KEYWORDS

Ventilation, water sprays, methane, coal mining, dust scrubber

INTRODUCTION

Effective face ventilation requires that the intake air delivered to the end of the tubing or brattice reach the face. Studies have shown that often only a small fraction of the intake air actually reaches the face (Thimons, 1999). The amount of air reaching the face usually decreases with increasing tubing or curtain setback distance. Research conducted during the development of extended cut mining methods demonstrated that machine-mounted water sprays and scrubbers could be used to help direct additional intake air to the mining face when setback distances exceeded 6.1 m (20 ft) (Volkwein, 1985).

Although designed primarily for dust control, machine-mounted water sprays and scrubbers play an important role in increasing the amount of intake air that reaches an extended cut mining face. A water spray moves air like a small fan. When used with exhaust ventilation, groups of sprays directed 30° toward the return side of the entry create airflow patterns that help clear methane from the face. On sections with blowing ventilation, the large quantities of air moved by machine-mounted dust scrubbers effect face airflow patterns. Tests using scrubbers with both blowing and

exhausting ventilation showed that operation of a scrubber always reduces face methane concentrations unless the scrubber exhaust flow interferes with the movement of the intake air toward the face (Taylor, 1996).

All mining sections use water sprays for dust control, but most sections with exhaust ventilation do not use scrubbers. Scrubbers and water sprays are used on most sections that have blowing ventilation. Past research to evaluate the effects of scrubber use on face methane levels has been conducted with the spray systems operating. Using a scrubber and sprays together reduced face methane levels for a range of setback distances, scrubber flows, and intake flows (Taylor, 1996). Another study showed that water spray systems, regardless of design, improved methane control when used with scrubbers. However, ventilation improved most when the spray system was directed toward the return side of the face (Volkwein and Wellman, 1989).

The current research is a continuation of earlier studies to evaluate how the combined use of scrubbers and water sprays affect face methane levels while using blowing ventilation. Tests were conducted for a range of operating conditions that included multiple drum heights and the use of side and underboom sprays.

TEST FACILITY

Gallery

Testing was conducted in the National Institute for Occupational Safety and Health's (NIOSH) Pittsburgh Research Laboratory Ventilation Test Gallery. One side of the „L” shaped building is designed to model an underground mining entry which is 5 m (16.5 ft) wide by 2.1 m (7 ft) high (Figure 1). An exhaust fan draws approximately 5.9 m³/sec (12,500 cfm) of air into the gallery. For these tests a brattice and wood curtain, constructed 0.6 m (2 ft) from the left side of the entry, directed 3.3 m³/sec (7,000 cfm) of intake air toward the face. Curtain setback distance for all tests was 12.2 m (40 ft). The return air was pulled from the gallery behind a brattice and wood wall built along the right side of the entry. A 1.2 m wide by 6.1 m long (4 ft by 20 ft) box was built along the right side of the face to simulate an uncut slab of coal. A box cut, rather than a slab cut configuration, was selected because changes in methane levels inby the cutting head are easier to detect in the more confined area of the box cut.

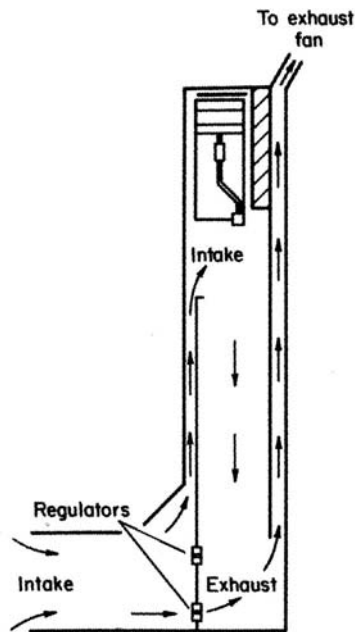

Figure 1. Ventilation test gallery

Mining Machine

A full-scale model mining machine was located at the center of the 3.8 m (12.5 ft) wide box cut face (Figure 2). During testing the cutting head rotated at 40 rpm and the center of the drum was positioned approximately 0.5, 1.0, 1.5 m (20, 40 or 60 in.) above the floor (Figure 3). These locations are referred to as the „down,” „middle,” and „up” drum heights.

The mining machine was equipped with a simulated dust scrubber. A fan mounted in the machine drew air into the two 25 by 36 cm (10 by 14 in.) inlets located on both sides, below and just behind, the machine boom. An orifice plate was placed in the scrubber duct to limit flow to approximately 3.3 m³/sec (7,000 cfm) for all tests where the scrubber was operating. Air from the scrubber was exhausted through a 38 by 38 cm (15 by 15 in.) opening at the right rear of the machine. Nine horizontal and 9 vertical louvers, each 4 cm (1.4 in.) wide were located at the exhaust opening (see Figure 2). By adjusting the louver direction, scrubber exhaust could be directed, up or down, right or left, and straight. For all tests of the spray systems and scrubber, the louvers were directed so that the scrubber exhaust was directed straight back the entry toward the return. Tests were also conducted to determine if the direction of the scrubber exhaust had an effect on face methane levels. For these tests exhaust flow direction was varied while using only one spray configuration.

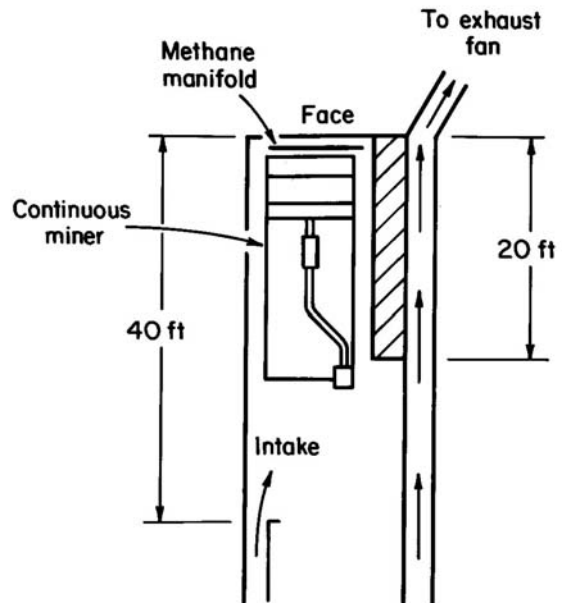

Figure 2. Model mining machine at face of box cut

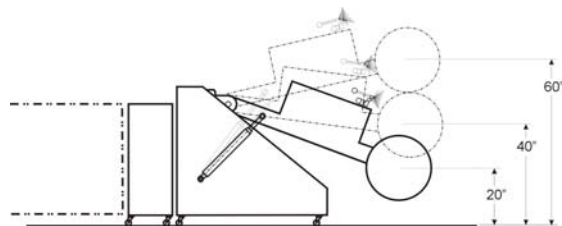

Figure 3. Drum test heights

Water Spray Systems

The water spray system included manifolds located on the top, on the side, and under the boom (Figure 4).

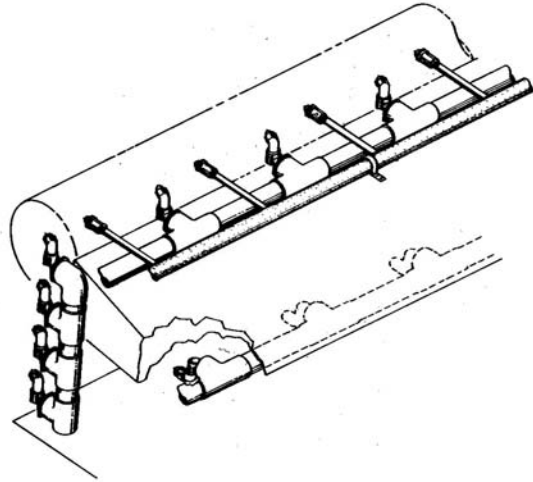

Figure 4. Spray locations on model mining machine

Top spray manifold: Ten BD-3 hollow jet nozzles were mounted approximately 0.3 m (1 ft) apart in each of two 3 m (10 ft) long plastic pipes located on top of the miner boom. The sprays in one pipe were directed straight toward the face. In the other pipe, they were directed 30° to the right. All spray nozzles were approximately 0.75 m (30 in.) from the face.

Side spray manifold: Four Vee-jet nozzles were positioned 0.15 m (6 in.) apart in a 0.7 m (28 in.) plastic pipe that was mounted vertically on the left side of the mining machine. The flat spray nozzles were aligned so that the spray pattern was vertical and directed toward the face.

Underboom spray manifold: Four BD-3 hollow jet nozzles were positioned 0.15 m (6 in.) apart in a 0.7 m (28 in.) plastic pipe that was attached to the underside of the cutting boom. The nozzles were mounted so that they were directed toward the face.

Water flow and pressure: A centrifugal pump was used to provide the desired water pressure which was measured with a gauge mounted near the front of the model mining machine. Flows and pressures varied depending on the number of operating sprays. For all tests using water sprays, pressures were maintained between 758 and 896 kPA (110 and 130 psi) and the flow was allowed to vary depending on the number of sprays operating. Pressure at the gauge was adjusted by redirecting part of the water flow at the pump.

METHANE RELEASE AND INSTRUMENTATION

Methane gas was released into the gallery through four horizontal copper pipes that were drilled on top and bottom with 2 mm (1/16 in.) diameter holes. The pipes were equally spaced horizontally, and located 0.1 m (4 in.) away from the face to provide a relatively uniform release of gas. Locations 1, 2, and 3 are 0.3 m (1 ft) from the roof and face, evenly spaced across the face; Locations 4, 5, and 6 are 1.2 m (4 ft) below.

Methane was released at a flow rate of approximately 1,300 lpm (45 cfm). For some tests, however, the gas flow was reduced to prevent concentrations in the gallery from exceeding 2 pct.

A vacuum pump was used to draw an air sample at 0.5 lpm (0.02 cfm) from each of the six sampling locations. Each air sample was drawn through 9 m (30 ft) of 0.6 cm (1/4 in.) plastic tubing and passed over an individual catalytic heat of combustion type sensor head.

TEST PROCEDURE

Prior to the start of each test the desired operating conditions were set. Next, methane gas was introduced into the gallery for 5 min to allow the gas and air to mix. After the mixture reached a relatively steady state concentration, data was collected at each location for 5 minutes.

Data from each methanometer was down-loaded every two seconds to a personal computer via an analog to digital conversion board. For each of the locations sampled, the average methane concentration for each five minute sampling period was calculated using an electronic spreadsheet file. Most tests were repeated once and the results averaged.

RESULTS

Tests were conducted with either the 30° or top sprays operating and the scrubber on. The average face concentrations for the six sampling locations were obtained for each of the three drum heights (Figure 5). For either spray system the highest concentrations were measured when the drum was up and the lowest when the drum was in the middle position. All additional tests to evaluate the water spray systems were conducted with the drum in the up position. Figure 6 shows the concentrations at the left, center, and right side of the face with the drum up and only the straight or 30° top sprays operating.

Tests were conducted to evaluate the top spray systems with underboom sprays (Figure 7), side sprays (Figure 8), and underboom and side sprays together (Figure 9). With the addition of side and/or underboom sprays, methane concentrations decreased or remained about the same except:

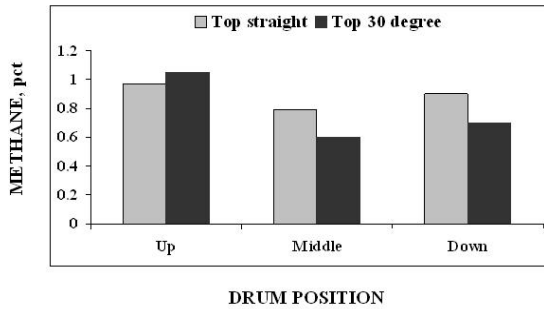

Figure 5. Effect of drum heights and top mounted sprays on methane levels

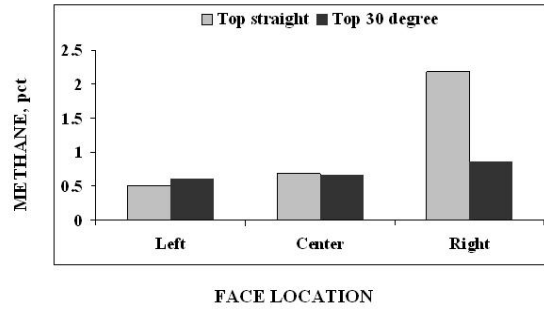

Figure 8. Using side sprays with the top sprays

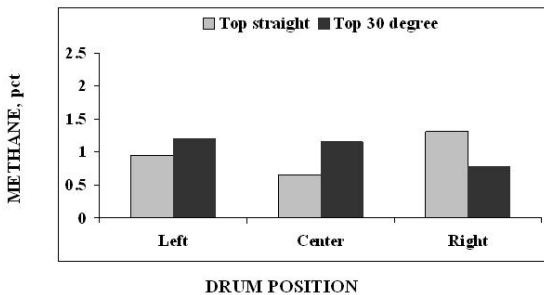

Figure 6. Effects of top strays at face sampling locations

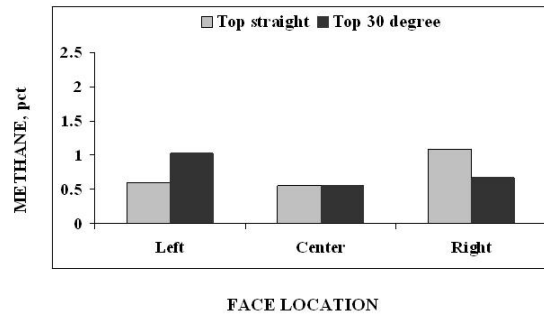

Figure 9. Combined use of underboom and side sprays with top sprays

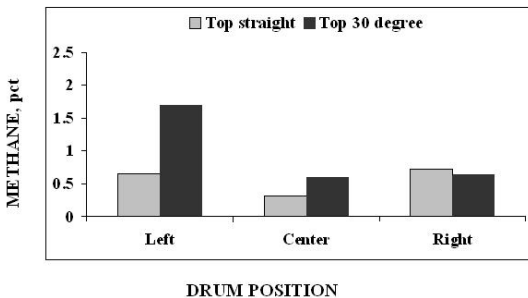

Figure 7. Using underboom sprays with the top sprays

- When using top 30° sprays and underboom sprays methane levels increased on the left side of the face 42 pct (see Figures 7 and 6). When the underboom and side sprays were used with the top 30° sprays, concentrations on the left side were 14 pct less than when only top sprays were used (see Figures 9 and 6).
- When using top straight sprays with the side sprays methane levels increased 66 pct on the right side of the face (see Figures 8 and 6). When the underboom and side sprays were used with the top straight sprays, concentrations on the right side were about 17 pct less than when only top sprays were used (see Figures 9 and 6).

Tests were conducted to determine how changing the direction of the scrubber exhaust would affect face methane concentrations. For these tests the top 30°, side, and underboom sprays were operating, and the drum was in the middle position. Face methane concentrations were reduced as the scrubber exhaust direction was moved from left to right (Figure 10). Changing the horizontal exhaust flow direction, up and down, had less of an effect on face methane levels.

DISCUSSION AND CONCLUSION

Operation of either water sprays or machine-mounted scrubber affects face airflow patterns. Using smoke tubes, airflow patterns were drawn with the scrubber and sprays on and off (Figure 11). Curtain setback distance was 12.2 m (40 ft) and intake flow quantity was 3.3 m³/sec (7,000 cfm). With only the blowing curtain, the ventilation flow created a „Figure 8” pattern that moved from the return to the intake side of the face.

Operation of either the scrubber or water sprays reversed the direction of the face airflow, resulting in movement from the intake to the return side of the face. Based on observations of the smoke flow, which indicated straighter and better defined flow with the scrubber, more intake air reached the face with the scrubber operating than with the sprays operating. Establishing a face airflow that moves from the intake

to return side of the entry is an important factor in reducing face methane levels.

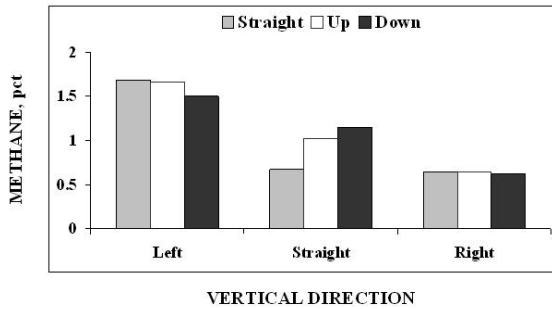

Figure 10. Effect of scrubber flow direction on face methane levels

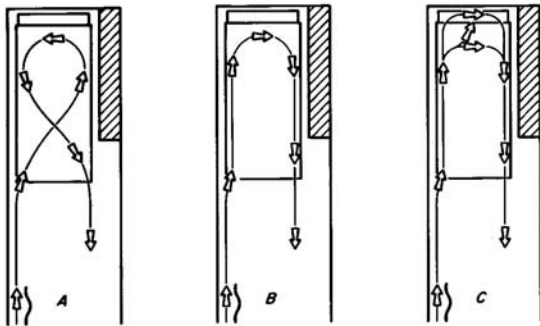

Figure 11. Face airflow patterns for (A) no water sprays or scrubber, (B) scrubber only, and (C) water sprays only

When both the sprays and scrubber were operating, flow turbulence in by the miner cutting boom made it difficult to observe the direction of the air movement. The distribution of methane measured during testing indicates that flow did move from the intake to the return side of the face, and the use of the top 30° sprays improved that flow direction.

In general, the lower the intake air velocity moving toward the face, the greater the effect water sprays will have on face airflow patterns. Sprays have a greater effect on face airflow when exhausting rather than blowing face ventilation is used. With blowing face ventilation, sprays primarily affect face airflow within 1 or 1.2 m (3 or 4 ft) of the face. They can have a significant effect on re-distributing the gas at the face, but the sprays have less effect on moving methane out of the face area.

For the conditions tested, which included a uniform release of methane at the face, methane levels were highest when the drum was up and lowest when the drum was in the middle position. In the up position most of the water from the top mounted sprays hit the roof before it could have a significant impact on face

airflow. In the middle position most of the spray reached the face and had a greater effect on face airflow.

Underboom sprays are often used on mining machines for dust control. The effect of underboom sprays used in combination with top and side sprays was evaluated. When used with the top 30° sprays, underboom sprays created turbulence that interfered with the movement of air across the face. The result was increased methane levels on the left side of the face. Addition of the side sprays directed more air flow to the left side of the face and reduced face methane levels at that location. Using the side sprays only with the top straight sprays increased methane levels on the right side of the face because the top straight sprays are less effective for moving gas out of the face area. Addition of underboom sprays to the top and side sprays increased turbulence enough to reduce methane levels on the right side of the face.

The direction of the exhaust flow had an effect on face methane concentrations. Face methane concentrations were highest when the vertical direction of the exhaust flow was toward the left or intake side of the face. Directing the exhaust to the left interfered with and reduced airflow toward the face. Directing scrubber flow to the right or return side of the entry had the least effect on intake flow and methane concentrations were lowest. Changing the horizontal, or up and down direction of the scrubber exhaust flow had less of an effect on face methane levels, although the gas concentrations were lower when the exhaust was directed downward. Scrubber exhaust should be directed so that it has the least effect on intake air moving toward the face. If the exhaust velocity over any worker is too high, the flow can be directed downward.

The conditions tested were designed to simulate face ventilation during mining of a box cut using blowing ventilation. Methane concentrations measured in an operating mine will vary depending on the actual operating conditions and the methane liberation rate in the face area. The results obtained provide guidelines for selection and use of water spray systems for use in improving face airflow and reducing methane concentrations at the face.

The guidelines are designed to reduce methane in the face area using water sprays and scrubbers, but will not necessarily reduce dust generated at the face by the mining operation. Water sprays increase turbulent airflow at the face that can improve dilution of methane with available intake air. Turbulent flow can increase dust levels if it creates excessive dust rollback. In some situations the use of a particular water spray system can reduce the collection efficiency of scrubbers by causing the dust to bypass the scrubber inlets. Studies to evaluate the effect of water sprays on dust and water for the same range of operating conditions are planned.

REFERENCES

- Taylor CD, Rider JP, and Thimons ED [1996]. „Changes in Face Methane Concentrations Using High Capacity Scrubbers with Exhausting and Blowing Ventilation," Proceedings of the SME Annual Meeting, Preprint 96-167, Phoenix, AZ, March 11-14, 5 pp
- Thimons ED, Taylor CD, and Zimmer JA [1999]. „Ventilating the Box Cut of a Two-Pass 40 ft Extended Cut," Journal of the Mine Ventilation Society of South Africa, Vol. 52, No.3, July/Sept., 108-115 pp
- Volkwein JC, Ruggieri SK, McGlothlin C and Kissell FN [1985]. „Exhaust Ventilation of Deep Cuts Using a Continuous-Mining Machine," Bureau of Mines Report of Investigation No. 8992, 16 pp
- Volkwein JC, Thimons ED, and Hallfanger G [1985]. „Extended Advance of Continuous Miner Successfully Ventilated With a Scrubber in a Blowing Section," 2nd U.S. Mine Ventilation Symposium, Reno, NV, Sept 23-25, pp. 741
- Volkwein JC, and Wellman TS [1989]. „Impact of Water Sprays on Scrubber Ventilation Effectiveness," Bureau of Mines Report of Investigation No. 9259, 12 pp