

INTRODUCTION TO MINE VENTILATING PRINCIPLES AND PRACTICES

By D. S. Kingery



UNITED STATES DEPARTMENT OF THE INTERIOR

Fred A. Seaton, Secretary

BUREAU OF MINES

Marling J. Ankeny, Director

This publication has been cataloged as follows:

Kingery, Donald Samuel.

Introduction to mine ventilating principles and practices.
Washington, U.S. Govt. Print. Off., 1960.

iv, 54 p. illus., tables. 26 cm. (U.S. Bureau of Mines. Bulletin
589)

Bibliography: p. 54.

1. Mine ventilation. I. Title. (Series)

TN23.U4 no. 589 622.06173

U.S. Dept. of the Int. Library

CONTENTS

	Page		
Introduction	1	PART I—Continued	
Acknowledgments	1	Natural-ventilation influence of air densities—	
Symbols and abbreviations	2	Continued	Page
Review of elementary fundamentals	2	Mine density	36
PART I		Weighted average of densities	38
Air measurements	5	Shaft A	38
Moderate-velocity airflow measurements	5	Shaft B	38
Low-velocity airflow measurements	8	PART II	
High-velocity airflow measurements	9	Application of airflow fundamentals	39
Influence of air density	13	Derivation of ventilating formulas	39
Fundamentals of airflow	16	Solution of problem examples	41
Pressure losses	16	Problem 1: Pressure volume computations	
Parallel flow in airways	17	for a new mine	41
Splitting air currents	18	Calculation of <i>R</i> factors	41
Air losses from leakage	22	Explanation of computation sheet	42
Mechanical ventilation	24	Problem 2: Fan pressure necessary to in-	
Selection of fans	24	crease air quantity in an old mine	43
Fan tests	27	Calculation of <i>R</i> factors	45
Fans in series	29	Problem 3: Practical application of fan laws	
Fans in parallel	30	and air densities	46
Fans in combination	35	Computation	46
Natural-ventilation influence of air densities	35	Problem 4: Improved face ventilation by	
Shaft A	35	means of new air shaft	48
Shaft B	36	Calculation of <i>R</i> factors	48
Surface density	36	Ventilation reference material	54

ILLUSTRATIONS

	Page		Page
Fig. 1. Illustration of static and velocity pressures	3	Fig. 16. Corrected fan-performance curve at average	
2. Anemometer calibration curve	6	local air density	27
3. One-half area traverse, left side	7	17. Pressure changes in a ventilating system for	
4. One-half area traverse, right side	7	blowing and exhausting fans	29
5. Bureau of Mines-type smoke-cloud gener-		18. Combined characteristics of two identical	
ator	8	fans operating in series	30
6. Smoke-cloud release	9	19. Combined characteristics of two different	
7. Example of smoke-cloud measurement	10	fans operating in series	31
8. Illustration of pitot tube	10	20. Two identical fans operating in parallel	32
9. Diagram position traverse points, circular-		21. Two different fans operating in parallel	32
air-measurement section	11	22. Parallel fans operating on separate airways	33
10. Airflow with natural splitting	18	23. Combined operation of two fans	34
11. Example of airflow splitting	20	24. Influence of natural draft to mechanical-	
12. Example of airflow splitting, with regulation	22	ventilation performance	36
13. Illustration of air-leakage losses	23	25. Example of conditions causing natural draft	37
14. Relationship between fan characteristic and		26. Mine and ventilation plan: Problem 1	42
mine resistance	25	27. Mine and ventilation plan: Problem 2	44
15. Comparison of characteristic curves for fan		28. Plotted fan data: Problem 3	47
operating at different speeds and blade		29. Line diagram: Problem 4	49
settings	26	30. Pressure gradient: Problem 4	50
		31. Graph of fan data: Problem 4	51
		32. Line diagram with new air shaft: Problem 4	53

TABLES

	Page		Page
1. Velocity-pressure data converted to velocity.....	12	4. Bureau of Mines schedule of friction factors	16
2. Approximate air densities for dry air at different temperatures.....	14	for mine airways.....	28
3. Temperature of dewpoint in degrees Fahrenheit (pressure=29.0 inches).....	15	5. Fan-test data sheet, fan exhausting.....	29
		6. Fan-test data sheet, fan blowing.....	

INTRODUCTION TO MINE VENTILATING PRINCIPLES AND PRACTICES¹

By

D. S. KINGERY²

Introduction

THE IMPORTANCE of the ventilating system in coal mining is recognized universally, and standards for ventilating requirements have been established by State mine-inspection departments and the Federal Coal Mine Safety Act.

Mine management, of course, is responsible for the effectiveness of the ventilating system and for compliance with State and Federal laws. Few companies employ ventilating engineers; the engineering department may plan the mine development and the ventilating system, but it falls upon the mine superintendents and the foremen to assure adequate ventilation for the working sections.

The fundamentals of airflow are taught in mining schools, and every mine supervisor must prove a working knowledge of these fundamentals before he is certified by the State. Most mine foremen, therefore, along with their practical knowledge, have a working knowledge of certain basic ventilating formulas. However, many ventilation problems require solution by more complex formulas, changing certain ventilation problems to mathematical exercises.

This bulletin is written to explain in layman language the basic laws and fundamentals of mine airflow and their application to the solution of common ventilating problems. It presupposes that the reader will possess at least an elementary knowledge of mine ventilation and of arithmetic and algebra. Our attempt is to reduce the complex and difficult ventilating formulas to simple, practical fundamentals.

We have taken certain liberties with well-known theories of airflow principles, believing that it is unrealistic to apply higher mathematics and refinements to ventilating problems, the data of which are based upon assumption or relative field measurements of air quantities and pressures. For example, in our velocity-pressure conversions to velocity, we will use 4,000 f.p.m., rather than the accurate 4,008 feet, as equivalent to 1 inch water pressure. In calculations we will use averages rather than integrate between limits.

This bulletin was prepared for use by mine personnel interested in and responsible for mine-ventilation operations.

ACKNOWLEDGMENTS

The author has drawn from knowledge gained piecemeal from many sources—books, periodicals, publications, Bureau of Mines records, and practical experience. Special assistance was given by members of the Ventilation Group, Federal Bureau of Mines, and the several qualified ventilating engineers who reviewed the manuscript and submitted constructive suggestions. Special acknowledgment also is given to G. E. McElroy, former Bureau of Mines ventilation engineer, with whom the author worked closely for several years.

¹ Work on manuscript completed July 1959.

² Director, Health and Safety Research and Testing Center, Pittsburgh, Pa.

SYMBOLS AND ABBREVIATIONS

<p>A..... cross-sectional area of airway, square feet. B..... barometric pressure, inches mercury. cu..... cubic. c.f.m.... cubic feet per minute (of air). D..... diameter of duct or pipe. d..... density of dry mine air, pounds per cubic foot. d_w..... density of mine air and water vapor, pounds per cubic foot. f..... vapor pressure at dewpoint, inches mercury. ft..... linear feet. f.p.m.... feet per minute. f.p.s.... feet per second. ° F..... degrees Fahrenheit. g..... influence of gravity, 32.2 f.p.s. H..... ventilating pressure in inches water. hp..... horsepower. H₂O..... water. K..... coefficient of friction (friction factor). L..... length of airway in feet. lb..... pound, pounds.</p>	<p>min..... minute, minutes. n.v.p.... natural ventilating pressure. O..... perimeter of airway. P..... ventilating pressure, pounds per square foot. p.c.f.... pounds per cubic foot. p.s.f.... pounds per square foot. q..... air quantity, cubic feet per minute. Q..... air quantity, expressed in units of 100,000 c.f.m. R..... resistance factor of mine or airway. SP..... static pressure. sq. ft... square feet. T..... temperature, dry bulb. TP..... total pressure. t_w..... temperature, wet bulb. VP..... velocity pressure. V_R..... relative average velocity of airflow uncorrected. V_T..... average velocity of airflow corrected.</p>
---	---

REVIEW OF ELEMENTARY FUNDAMENTALS

Air Quantity.— q is the amount of air flowing through a mine or a segment of a mine, in cubic feet per minute. Air quantity is the product of the air velocity times the cross-sectional area of the airway. $q = V \times A$.

Velocity.— V is the rate of airflow in lineal feet per minute and is measured by anemometers or other instruments and the time it takes for smoke to travel over measured distances.

Area.— A is the cross-sectional area of the entry or duct through which the air flows, expressed in square feet.

Perimeter.— O is the linear distance in feet of the airway perimeter rubbing surface at right angles to the direction of the airstream.

Airflow.—When air flows slowly along the walls of the containing airway and around obstructions without causing eddy currents or turbulence, the flow is called streamline. The rate of streamline flow will be approximately 10 f.p.m. or less. Such flow in mines is often referred to as air seepage.

When the airspeed increases, the flow characteristic changes from streamline to turbulent. With turbulent airflow, the energy of air in motion is great enough to bounce air particles off the walls of the containing airway and obstructions increasing pressure losses due to friction and eddy currents.

Normally, in mine airways and ducts airflow is turbulent.

Pressures.—Some kind of pressure is neces-

sary to cause airflow between points in an air circuit or mine.

The purpose of a fan is to supply mechanically produced pressure at some point in the mine-ventilating circuit. In addition to mechanical pressure, atmospheric or barometric pressure also influences airflow in a mine. The algebraic sum of the mechanical draft pressure and the atmospheric natural ventilating pressure comprises the mine ventilating pressure.

If the pressure in the mine or duct is at a lower pressure than atmospheric or other base pressure, the system is negative, or *exhausting*. If the opposite is true, the system is positive, or *blowing*.

The method of measuring pressures is usually by water gage or other form of differential pressure gage. For special surveys, precision altimeters³ or barometers are used with the pressure data converted to inches water gage.

Water Gage.—The water gage or standard U-tube is a common instrument that indicates differential pressures in inches of water. The pressure in inches of water can be converted into pounds per square foot, P , by multiplying the water gage reading by 5.2, the conversion factor.

The conversion factor of 5.2 p.s.f. is derived from the fact that 1 cubic foot of water weighs 62.5 pounds. If one-twelfth of this weight is

³ McElroy, G. E., and Kinery, D. S., Making Ventilating-Pressure Surveys With Altimeters: Bureau of Mines Inf. Circ. 7809, 1957, 20 pp.

the weight of 1 inch of water, it is equal to $62.5 \div 12 = 5.2$ p.s.f. (fig. 1).

Pressure necessary to move air consists of static, velocity, and, when combined, the total pressure. (See fig. 1.)

Static Pressure (SP): Pressure, either negative or positive, exerted in all directions. May be compared to atmospheric pressure.

Velocity Pressure (VP): Pressure exerted by the kinetic energy of air movement.

Total Pressure (TP): Algebraic sum of the

static pressure and velocity pressure, either negative or positive.

Static Pressure Loss or Regain.—The total pressure remains constant except for energy loss caused by airflow. However, the velocity of the airstream will vary with any changes in the area of the airway; consequently, the velocity pressure also will change. With velocity-pressure changes, there must be a corresponding change in the static pressure. For example, if the area doubles in an airway, the air velocity

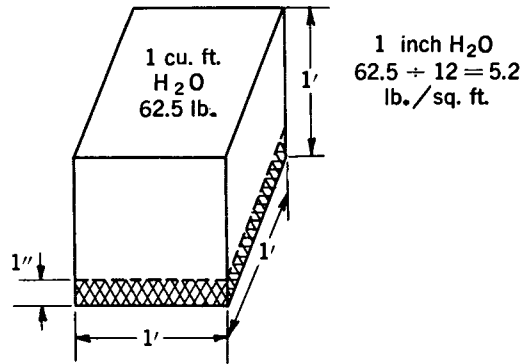
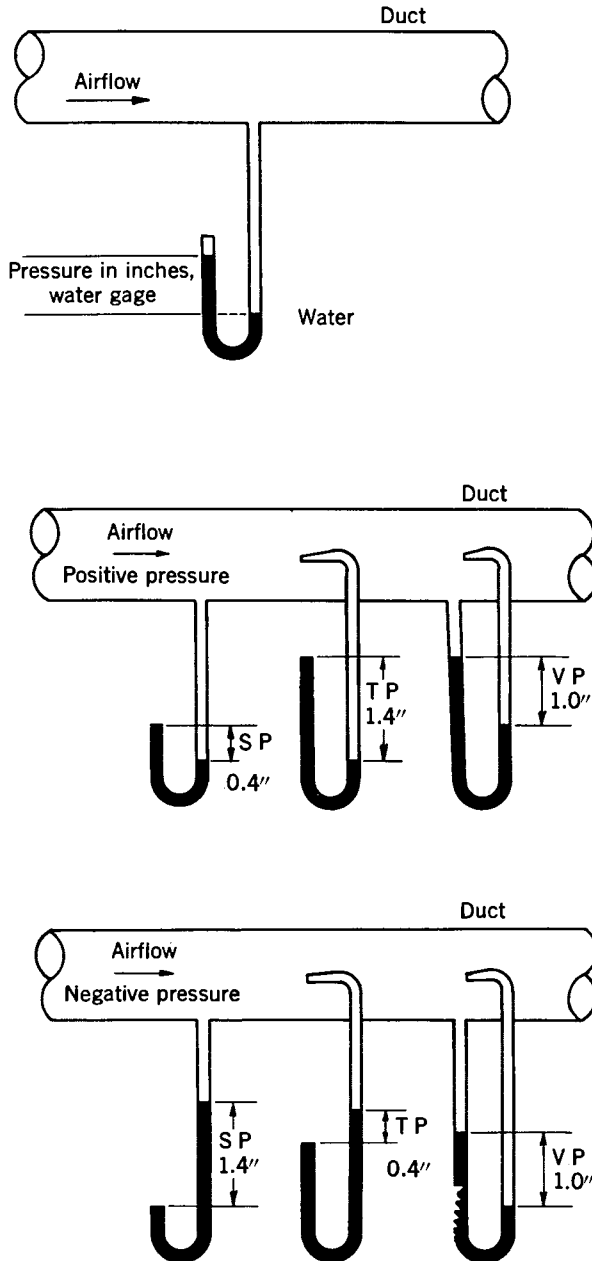

- (S P) Static pressure is pressure exerted in all directions.
- (V P) Velocity pressure is directional pressure involving movement of kinetic energy.
- (T P) Total pressure is the sum of both static and velocity pressures.

FIGURE 1.—Illustration of Static and Velocity Pressures.

moving through the single airway changes. The velocity automatically will be reduced one-half for the same air quantity; the static pressure theoretically increases corresponding to the decrease in velocity pressure.

Air Temperatures and Psychrometric Data.—Mine-air temperatures influence air densities; consequently air temperatures and the moisture content of the air (relative humidity) must be determined before true air densities can be calculated.

The measuring instrument is a sling psychrometer—an assembly of two thermometers mounted in a frame, equipped with a pivoted handle to whirl the thermometers and obtain the necessary movement of air. The wet bulb of the thermometer used for wet-bulb readings is specially covered with muslin, which extends into a water well across the bottom of the psychrometer.

The psychrometer is used by wetting the muslin cover of the wet bulb and then whirling the psychrometer in the airstream. The whirl-

ing action causes evaporated cooling of the wet bulb, which lowers the recorded temperature. The dry bulb is not influenced and records the sensible heat of the mine air. By using standard psychrometric tables with wet- and dry-bulb air-temperature measurements, the relative humidity can be determined. Vapor pressure is another pressure that affects air densities and is influenced by the moisture content of the air. It also can be determined from psychrometric tables or charts.

Barometric Pressure.—Barometric pressures usually are recorded in inches mercury. The standard sea-level atmospheric pressure is 14.7 p.s.i. at 29.9 inches mercury. At different elevations above sea level, the barometer reads less, since the air column above the instrument is less.

Standard Air Density.—The standard density of air for mine-ventilation work is considered to be 0.075 p.c.f. This is based upon the weight of 1 cubic foot of dry air at 70° F. at a sea-level pressure of 29.9 inches mercury.

PART I

AIR MEASUREMENTS

The accuracy of the air quantities that are determined will of course depend on many factors. The most important is the care used when selecting measuring stations, determining velocities, and cross-sectional areas. Most air-quantity determinations for coal mines do not need to be absolutely correct; in fact, careful underground measurements probably will be only 90 to 95 percent correct. The day-to-day centerline measurements made by underground foremen as relative or comparative measurements are satisfactory in most instances. However, air traverses are necessary when making air-quantity surveys, fan tests, pressure surveys, and certain other investigations.

The air-quantity survey should be made twice yearly to determine and locate air-leakage losses and check fan operating efficiency. Air-quantity surveys are necessary in conjunction with pressure surveys to determine resistance factors. These measurements should be made as accurately as possible, otherwise the resultant data may not reveal important deficiencies of the ventilating system.

MODERATE-VELOCITY AIRFLOW MEASUREMENTS

For measuring velocities from 120 to 2,000 f.p.m., ordinary commercial types of medium-velocity vane anemometers are practical, convenient, and accurate. The vane anemometer is a small windmill geared to a mechanical counter through a small clutch, which is engaged for recording revolutions. The common commercial size is 4 inches in diameter. For ordinary rough measurements, the anemometer is held in the hand. For precise work, the anemometer should be mounted on a shaft to reduce the effect of the hand, arm, and body on the airstream. Anemometer readings are virtually independent of the air densities and air temperatures encountered in underground work. Another advantage is that readings are only slightly influenced by nonparallel flow.

Contrary to the opinions of some mining engineers that the anemometer is not reliable within the medium-velocity range, if used prop-

erly the anemometer is the most practical instrument for determining such air velocities.

Vane anemometers register a velocity somewhere within plus or minus-10 percent of the true velocity. Calibrations furnished by the manufacturer with new instruments are usually in the form of tables of plus-or-minus corrections to be made to observed velocities.

The application of these correction factors can be simplified by plotting the true velocity (V_T) in feet per minute against the registered velocity (V_R) (anemometer reading in feet per minute) and determining the equation $V_T = A + B V_R$ for the resulting line. In this general equation, V_T is the true velocity, V_R is the registered velocity, and A and B are constants for the particular anemometer. Figure 2 shows the plot of calibration data for a standard anemometer. The plotted data fall approximately into a straight line; the constant A is the increment that this line crosses the true velocity ordinate (vertical line through zero, fig. 2) above the zero point. The constant B is the ratio of the true velocity to the registered velocity or slope of the line. This formula, $V_T = 30 + 0.95 V_R$, while not exact for all points, is within the limit of error in use. For example, at a registered velocity of 200 f.p.m., true velocity = $30 + 0.95 \times 200 = 220$ f.p.m., compared with 210 f.p.m. for the anemometer correction table. For a registered velocity of 500 f.p.m., true velocity = $30 + 0.95 \times 500 = 505$ f.p.m., compared with 504 f.p.m. for the anemometer correction table. This equation is easy to use; each anemometer can be marked, and corrected velocities can be determined at the time of measurement. Manufacturer's correction cards often are lost, and when this happens the value of the anemometer for more precise measurements is destroyed unless calibrated by some method.

The common method of determining air velocities in coal-mine entries is by one-point measurements. That is, the anemometer is held at the center of the section. For day-to-day comparison, such one-point measurements, provided they are taken at the same place, are satisfactory. For more accurate determinations, traversing methods should be employed, since the air velocity is highest at the center

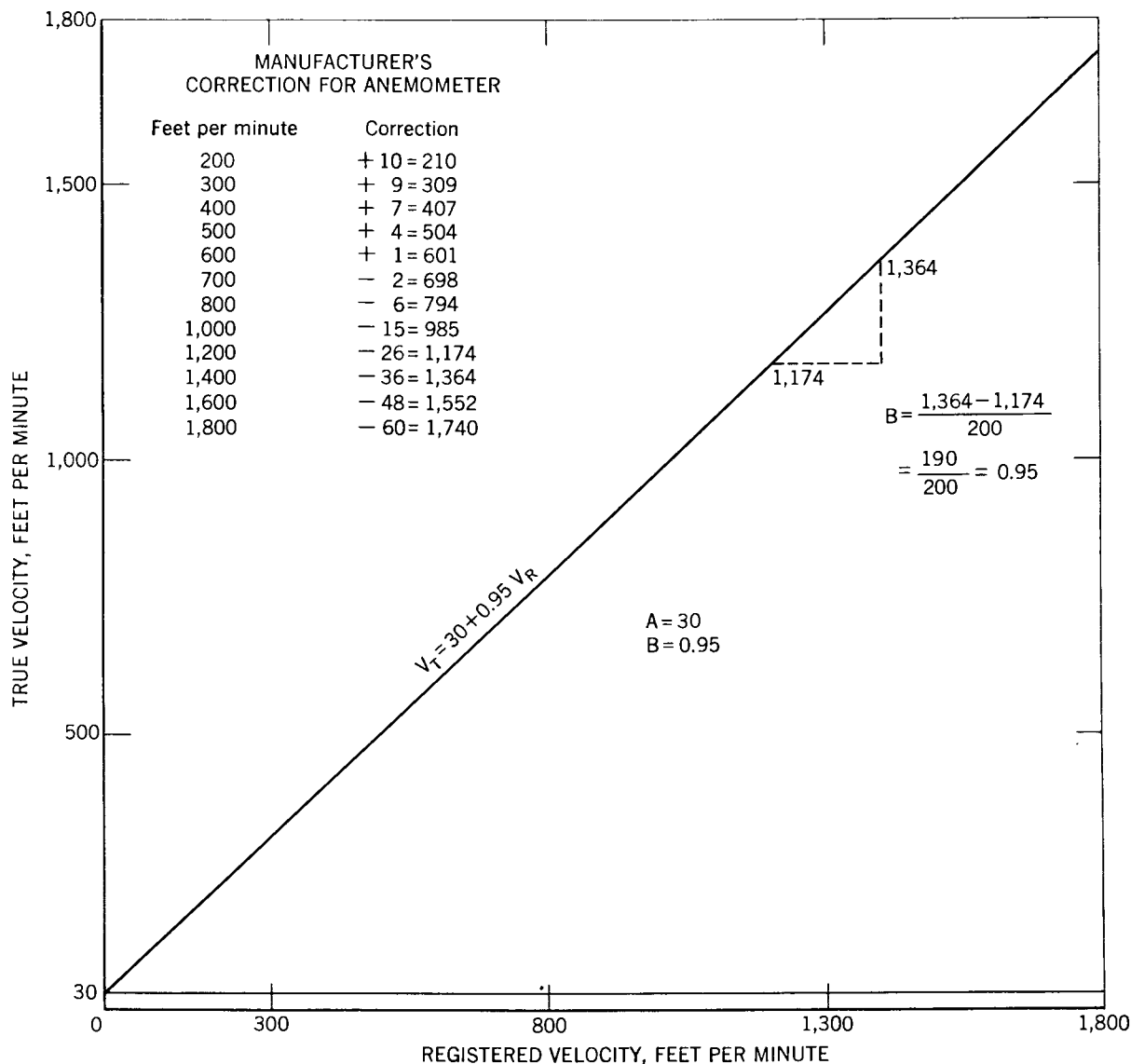

FIGURE 2.—Anemometer Calibration Curve.

and less at the sides. Approximate continuous traverses, made by moving the anemometer slowly through a plane at right angles to the axis of the airway, are recommended. One common method is to divide the airway into two equal areas and traverse each area separately, keeping the body out of the airstream being measured (figs. 3 and 4). The time interval for conducting measurements varies with the accuracy desired. If the half-area traverse is employed, 1-minute measurements of each area checked by $\frac{1}{2}$ -minute traverses are common. All air measurements should be checked by repeat measurements until a satisfactory comparison of velocities is obtained. With a little practice, check measure-

ments within 2 percent can be obtained under most conditions in coal mines.

Precise traversing methods with anemometers are justifiable only on major air currents, in connection with tests of fan performance, or to determine pressure-quantity relations. They should be applied only at sections of regular area on straight airways and away from any disturbing influence. Air-measuring stations with located traverse points are necessary when precise measurements are required. Traverse points can be located by strings, wires, or marks on guide frames at centers of equal areas of cross sections. The number of areas depends on the conditions of flow and should not be less than 16 for a square section or less



FIGURE 3.—One-Half Area Traverse, Left Side.



FIGURE 4.—One-Half Area Traverse, Right Side.

than 24 for a section in which one dimension is twice the other.

When measuring airways of divided sections, such as an entry that has been center-posted, the air quantity for each division should be determined separately because the posts change the velocity contours of the airstream, both upstream and downstream, making it difficult to obtain consistent measurements.

LOW-VELOCITY AIRFLOW MEASUREMENTS

Unless special low-speed anemometers are available for determining direction and velocity of air currents below 120 f.p.m., smoke-cloud methods offer practical means. The accuracy of the method is acceptable for most mine-air measurements. Figure 5 shows the Bureau of Mines type of smoke-cloud aspirator and smoke tube.

To determine velocities by smoke-cloud

travel, measure a known distance along as straight and uniform a section as can be found in the airway. This distance will be determined by how well the smoke cloud holds together and how well it can be seen. Twenty-five feet usually is suitable. Determine the average area of the section along the measured distance. The average of three area measurements is usually enough unless the cross-sectional area is very irregular. Measurements are taken by a man with the smoke generator at the upstream point (fig. 6) and the timer with a stopwatch at the downstream point. Smoke clouds are released at quarter points (fig. 7), and the time that it takes the smoke cloud to travel the measured distance is recorded. Each velocity determination should be repeated several times. Abnormal highs or lows should be discarded, and the remainder averaged. With travel at about the quarter points, readings will average about 10-percent high. Consequently, this correction must be applied.



FIGURE 5.—Bureau of Mines-Type Smoke-Cloud Generator.

Example of observed smoke-cloud measurement data

(Distance, 25 feet, in seconds)

Quadrant	Measurements					Average, seconds
	1	2	3	4	5	
Upper right	9	11	12	11	10	10.6
Lower right	13	11	12	out	12	12.0
Upper left	11	11	10	12	10	10.8
Lower left	14	15	13	13	13	13.6
Total						47.0

CALCULATIONS

Final average = $47 \div 4 = 11.8$ seconds.

Velocity = $\frac{60}{11.8} \times 25 = 127.1$ f.p.m. Velocity equals the distance of smoke travel divided by the time in seconds, multiplied by 60 to convert the final velocity to feet per minute.

Correction for flow, 10 percent; $[127.1 \times 90 \text{ percent} = 114 \text{ f.p.m.} = V_T$, the true velocity after corrections.

Area: Average of three measurements (fig. 7) = 101 sq. ft.

Area quantity = $A \times V_T = 101 \times 114 = 11,500$ c.f.m.

HIGH-VELOCITY AIRFLOW MEASUREMENTS

The use of the ordinary vane anemometer in velocities over 2,000 f.p.m. may crack the bearings. Special high-speed anemometers, usually with half as many vanes as the standard type, are made for this work but, except for special tests, seldom are required for mine work. The high velocities most often encountered are those flowing in ducts or tubing where measurements by anemometer is difficult. For such measurements the most practical instrument is the pitot tube (see fig. 8), which can be inserted through a small hole in the duct or tubing, thereby permitting velocity pressures to be determined by a U-tube water gage or some other differential pressure gage.

The pitot tube is a primary standard instrument for determining velocities. Commercial types generally are accurate to within 1 percent, and specially made types can be accurate to within 0.01 percent. The usual form (fig. 8) is two concentric tubes, one within



FIGURE 6.—Smoke-Cloud Release.

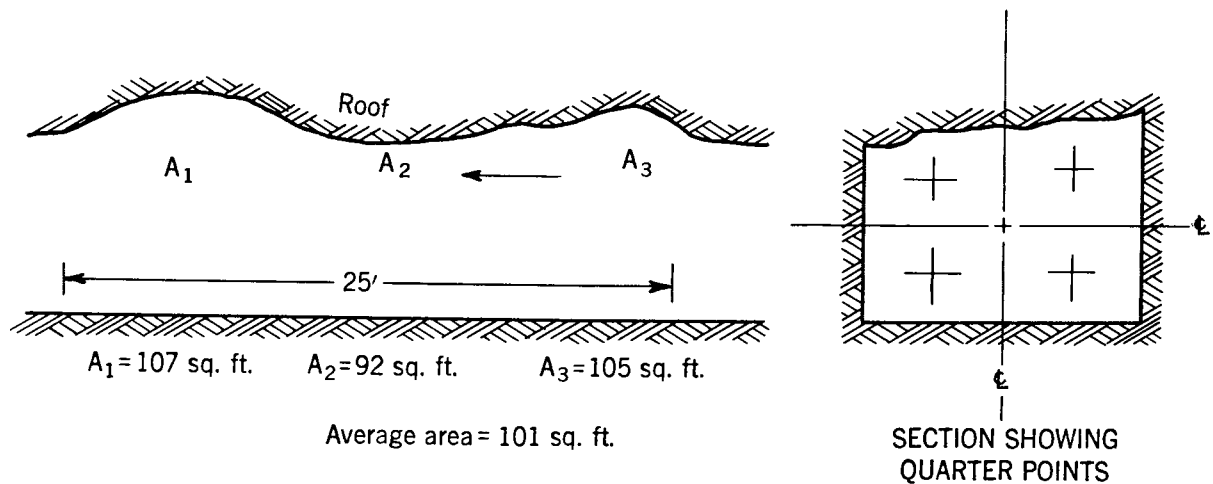

FIGURE 7.—Example of Smoke-Cloud Measurement.

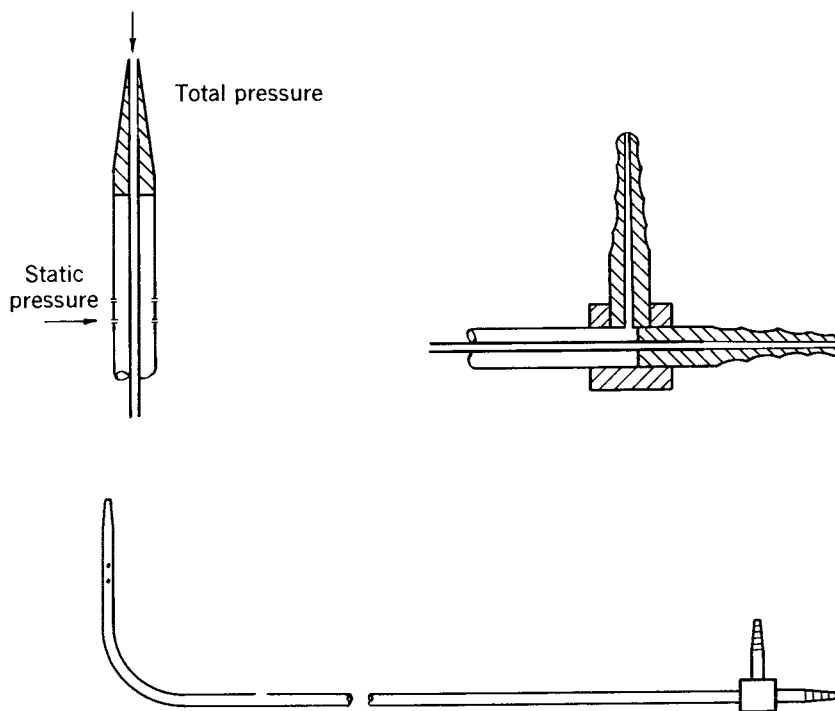

FIGURE 8.—Illustration of Pitot Tube.

the other, with the end bent at right angles to the shaft. The inner tube is open on the end and receives the total pressure of the airstream. The outer tube is closed on the end and receives the static pressure of the airstream through a number of pinholes set back from the end. The tip is tapered or made hemispherical to reduce interference with the airstream. The opposite end of the pitot tube is provided with two fittings, one for each tube, to which the legs of the water gage are attached. When the legs of a water gage are attached to the pitot tube, the

difference in pressures between the inner and outer tubes, as registered by the U-tube, is the velocity pressure. The tapered end of the pitot tube must be pointed against and parallel to the airstream. Figure 1 shows how the pitot tube and water gage are used to determine static and total pressures in addition to velocity pressures in ducts or fan housings. Since velocity pressures ordinarily are small (a velocity of 2,000 f.p.m. at standard air density equals $\frac{1}{4}$ -inch water gage), the use of the pitot tube is limited to special high-velocity determinations in ducts

or tubing. When measuring air velocities in ducts or tubing, again the relative accuracy of centerline versus traverse measurements becomes important. Consequently, the end use of the data will determine the degree of accuracy needed. For most mine work, other than special tests, centerline measurements multiplied by a correction factor of 90 percent is sufficiently accurate. For special tests requiring a high degree of accuracy, point traverses should be made. Square ducts can be divided into a number of imaginary squares, and determinations made at the center of each square, measuring the distance that the pitot tube penetrates the duct. A number of holes in the duct opposite the row of squares to be measured are necessary. These holes can be plugged when not used. With round ducts the problem of obtaining average velocities is substantially more difficult.

The problem is to divide the cross-sectional area of the duct into equal areas, which can be sampled. Figure 9⁴ shows the position of traverse points in a circular air-measurement section for a 5-area, 20-point traverse. Four

holes are necessary in the horizontal and vertical diameters of the circular section to make the measurements.

Pitot-tube determinations of velocity pressures in inches of water can be changed into velocity of airflow, feet per minute, either by calculation or by reference to conversion tables. Conversion tables (see table 1) are simple to use. For example, the velocity represented by a velocity pressure of 0.78 inch water is 3,533 f.p.m. If tables are not available or do not cover the specific measurement, calculations can be made direct from the velocity pressures. The simplified formula for standard air density of 0.075 p.c.f. is:

$$\text{Velocity (f.p.m.)} = 4,000\sqrt{VP} \text{ inches water.}$$

EXAMPLE: What velocity is represented by a velocity pressure of 1.2 inches water? If this is a centerline reading, what is the corrected velocity?

$$V = 4,000 \sqrt{1.2}$$

The square root of 1.2 = 1.096;

therefore

$$\text{The velocity} = 4,000 \times 1.096 = 4,384 \text{ f.p.m.}$$

⁴ McElroy, G. E., Engineering Factors in the Ventilation of Metal Mines: Bureau of Mines Bull. 385, 1935, fig. 3-B, p. 11.

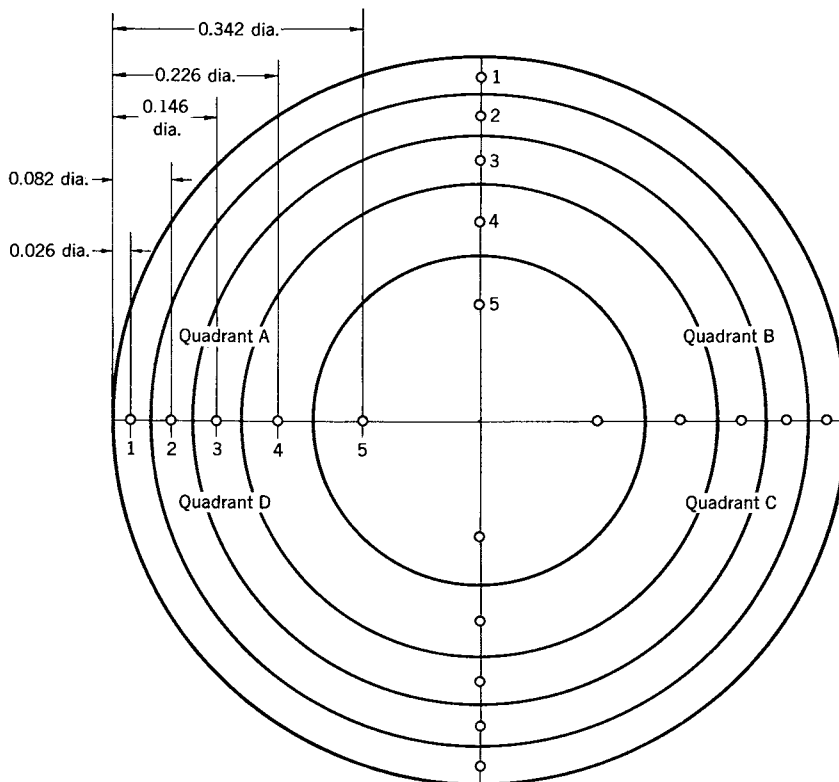

FIGURE 9.—Diagram Position of Traverse Points, Circular Air-Measurement Section.

TABLE 1.—*Velocity-pressure data converted to velocity* V_P =Velocity pressure, inches water. V =Velocity, feet per minute; also $4,000 \sqrt{VP}$.

V_P	V	V_P	V	V_P	V	V_P	V	V_P	V
0.10	1,265	0.69 .70	3,323	1.29 1.30	4,525	1.89 1.90	5,470	2.49 2.50	6,274
	1,327		3,346		4,533		5,485		6,286
	1,386		3,370		4,561		5,499		6,299
	1,442		3,394		4,580		5,514		6,312
	1,497		3,418		4,596		5,528		6,325
	1,549		3,441		4,613		5,543		6,337
	1,600		3,464		4,630		5,557		6,350
	1,649		3,487		4,648		5,571		6,362
	1,697		3,510		4,665		5,586		6,375
	1,743		3,533		4,682		5,600		6,387
	1,789		3,555		4,699		5,614		6,400
	1,833		3,578		4,716		5,628		6,412
	1,876		3,600		4,733		5,643		6,425
	1,918		3,622		4,750		5,657		6,437
.20	1,960	.80	3,644	1.40	4,767	2.00	5,671	2.60	6,450
	2,000		3,666		4,783		5,685		6,462
	2,040		3,688		4,800		5,699		6,475
	2,078		3,709		4,816		5,713		6,487
	2,116		3,731		4,833		5,727		6,499
	2,154		3,752		4,850		5,741		6,512
	2,191		3,774		4,866		5,755		6,524
	2,227		3,795		4,883		5,769		6,536
	2,263		3,816		4,899		5,783		6,548
	2,298		3,837		4,915		5,797		6,560
	2,332		3,857		4,932		5,810		6,573
	2,366		3,878		4,948		5,824		6,585
	2,400		3,899		4,964		5,839		6,597
	2,433		3,919		4,980		5,851		6,609
.29 .30	2,466	.89 .90	3,940	1.49 1.50	4,996	2.09 2.10	5,865	2.69 2.70	6,621
	2,498		3,960		5,012		5,879		6,633
	2,530		3,980		5,028		5,892		6,645
	2,561		4,000		5,044		5,906		6,657
	2,592		4,020		5,060		5,919		6,669
	2,623		4,040		5,075		5,933		6,681
	2,653		4,060		5,081		5,946		6,693
	2,683		4,079		5,107		5,960		6,705
	2,713		4,099		5,122		5,973		6,717
	2,742		4,118		5,138		5,987		6,729
	2,771		4,138		5,154		6,000		6,741
	2,800		4,157		5,169		6,013		6,753
	2,828		4,176		5,185		6,027		6,765
	2,857		4,195		5,200		6,040		6,776
.49 .50	2,884	1.09 1.10	4,212	1.69 1.70	5,215	2.29 2.30	6,053	2.89 2.90	6,788
	2,912		4,233		5,231		6,066		6,800
	2,939		4,252		5,246		6,079		6,812
	2,966		4,271		5,261		6,093		6,823
	2,993		4,290		5,276		6,106		6,835
	3,020		4,308		5,292		6,117		6,847
	3,046		4,327		5,307		6,132		6,859
	3,072		4,345		5,322		6,144		6,870
	3,098		4,363		5,337		6,158		6,882
	3,124		4,382		5,352		6,171		6,893
	3,150		4,400		5,367		6,184		6,905
	3,175		4,418		5,381		6,197		6,917
	3,200		4,436		5,396		6,210		6,928
	3,225		4,454		5,411		6,223		
.60	3,250	1.20	4,472	1.80	5,426	2.40	6,235	3.00	
	3,274		4,490		5,441		6,248		
	3,299		4,508		5,455		6,261		

The corrected velocity for a centerline measurement is

$$4,384 \times 90 \text{ percent} = 3,946 \text{ f.p.m.}$$

When determining the average of several readings made with a pitot tube to determine true velocities, the average velocity of a section cannot be obtained by the direct average of the velocity pressures obtained at traverse points, because velocity pressures vary as the square of the velocities. The simplest method is to determine first the velocity pressures of each traverse point, then the square root, and average the square roots. Otherwise, the velocities of the separate traverse points must be determined and averaged.

EXAMPLE: What is the average velocity represented by the following velocity pressures at traverse points across a circular section? (The following velocities will not compare exactly with velocities listed in table 1, since the square roots of the velocity pressures were carried only to two decimal places in the example, while those shown by table 1 were calculated more accurately. The results obtained are sufficiently accurate for most uses.)

Point	VP	\sqrt{VP}	V, f.p.m.
1	0.72	0.85	3,400
2	.77	.88	3,520
3	.83	.91	3,640
4	.95	.97	3,880
5	.84	.92	3,680
6	.77	.88	3,520
7	.74	.86	3,440
Total		6.27	25,080
Average		.896	3,583

Average velocity calculated, $4,000 \times 0.896 = 3,584$ f.p.m., compared with 3,583 f.p.m. for the average velocity.

INFLUENCE OF AIR DENSITY

The density of the air is considered unimportant when measuring with an anemometer or with a smoke tube, as the density influence with these devices is minor and within a normal error of measurements. When measuring by pitot tube, however, the air density should be considered if a substantial variance exists from standard air density of 0.075 p.c.f. Temperatures, barometric pressures, and relative humidity are variables that must be considered. The correction factor to be used with air densities other than standard is: The square root of 0.075 (standard density) divided by the true density

$= \sqrt{\frac{0.075}{d}}$. This correction factor, multiplied by the velocity, equals the true velocity within a practical degree of accuracy.

EXAMPLE: What is the velocity represented by a velocity pressure of 1.31 when the air density is 0.062 p.c.f.?

$$\begin{aligned} V &= 4,000 \sqrt{1.31} \times \sqrt{\frac{0.075}{0.062}} \\ &= 4,000 \sqrt{1.31} \times \sqrt{1.21}, \\ &= 4,000 \times 1.145 \times 1.10, \\ &= 4,000 \times 1.26, \\ &= 5,040 \text{ f.p.m.} \end{aligned}$$

From tables:

$$\text{Velocity at velocity pressure } 1.30 = 4,580,$$

$$\begin{aligned} V_T &= 4,580 \times \sqrt{\frac{0.075}{0.062}} \\ &= 4,580 \times \sqrt{1.21}, \\ &= 4,580 \times 1.10, \\ &= 5,038 \text{ f.p.m.} \end{aligned}$$

Air densities may be determined from charts or can be calculated from available data. The general formula is:

$$d = \frac{1.327}{460 + T} B; \text{ d} = \text{density, p.c.f.},$$

T = temperature air, ° F. dry bulb,

B = barometer, inches mercury,

460 = conversion to absolute temperature.

Absolute temperature is the theoretical temperature at which the volume of a gas is reduced to zero; consequently it ceases to exist as a gas. On the Fahrenheit scale such a temperature is -460° .

1.327 = conversion factor.

EXAMPLE: What is the air density at 70° F., with the barometer at 28.75 inches mercury?

$$\begin{aligned} d &= \frac{1.327}{460 + 70} \times 28.75, \\ &= \frac{1.327}{530} \times 28.75, \\ &= 0.072 \text{ p.c.f.} \end{aligned}$$

The above formula is accurate for dry air only but is generally used for density determination unless precise densities are required. Table 2 gives the approximate air densities for dry air at different temperatures.

The formula for precise air-density determination is:

$$d = \frac{1.327}{460 + T} (B - 0.378 f).$$

The units are the same as the previous air-density formula, except that (*f*), the influence of the vapor pressure in inches of mercury at the dewpoint, has been included. The use of this formula requires that psychrometric tables (table 3) or charts must be available.

EXAMPLE: What is the air density under the following conditions: Wet bulb=60° F., dry bulb=70° F., *B*=28.75 inches mercury, and

$$d = \frac{1.327}{460 + 70} (28.75 - 0.378 f).$$

(Ref., table 3.)

The temperature of the dewpoint at 29 inches mercury and dry-bulb temperature 70° F. and 10° F. wet-bulb depression=53° F. The vapor pressure at 53° F.=0.402.

$$\begin{aligned} d &= \frac{1.327}{530} [28.75 - (0.378 \times 0.402)], \\ &= \frac{1.327}{530} (28.75 - 0.15), \\ &= \frac{1.327}{530} (28.60), \\ &= 0.0716 \text{ p.c.f.} \end{aligned}$$

Comparison between these calculations shows that the influence of the vapor pressure can be ignored for most mine-ventilating problems.

TABLE 2.—Approximate air densities for dry air at different temperatures

Barometer, inches	Air densities, p.c.f.																		
	0° F.	5° F.	10° F.	15° F.	20° F.	25° F.	30° F.	35° F.	40° F.	45° F.	50° F.	55° F.	60° F.	65° F.	70° F.	75° F.	80° F.	85° F.	90° F.
31.0	0.0894	0.0885	0.0875	0.0866	0.0857	0.0848	0.0839	0.0831	0.0823	0.0815	0.0807	0.0799	0.0791	0.0783	0.0776	0.0769	0.0762	0.0755	0.0748
30.5	0.0880	0.0870	0.0861	0.0852	0.0843	0.0834	0.0826	0.0818	0.0809	0.0801	0.0794	0.0786	0.0778	0.0771	0.0764	0.0756	0.0749	0.0743	0.0736
30.0	0.0865	0.0856	0.0847	0.0838	0.0829	0.0821	0.0812	0.0804	0.0796	0.0788	0.0781	0.0773	0.0766	0.0758	0.0751	0.0744	0.0737	0.0730	0.0724
29.5	0.0851	0.0842	0.0833	0.0824	0.0816	0.0807	0.0799	0.0791	0.0783	0.0775	0.0768	0.0760	0.0753	0.0746	0.0739	0.0732	0.0725	0.0718	0.0712
29.0	0.0837	0.0828	0.0819	0.0810	0.0802	0.0793	0.0785	0.0777	0.0770	0.0762	0.0755	0.0747	0.0740	0.0733	0.0726	0.0719	0.0712	0.0706	0.0700
28.5	0.0822	0.0813	0.0805	0.0796	0.0788	0.0780	0.0772	0.0764	0.0756	0.0749	0.0742	0.0734	0.0727	0.0720	0.0714	0.0707	0.0700	0.0694	0.0688
28.0	0.0808	0.0799	0.0790	0.0782	0.0774	0.0766	0.0758	0.0751	0.0743	0.0736	0.0729	0.0721	0.0715	0.0708	0.0701	0.0694	0.0688	0.0682	0.0676
27.5	0.0793	0.0785	0.0776	0.0768	0.0760	0.0752	0.0745	0.0737	0.0730	0.0723	0.0715	0.0709	0.0702	0.0695	0.0689	0.0682	0.0676	0.0670	0.0664
27.0	0.0779	0.0770	0.0762	0.0754	0.0746	0.0739	0.0731	0.0724	0.0717	0.0710	0.0702	0.0696	0.0689	0.0683	0.0676	0.0670	0.0663	0.0657	0.0651
26.5	0.0764	0.0756	0.0748	0.0740	0.0733	0.0725	0.0718	0.0710	0.0703	0.0696	0.0689	0.0683	0.0676	0.0670	0.0664	0.0657	0.0651	0.0645	0.0639
26.0	0.0750	0.0742	0.0734	0.0726	0.0719	0.0711	0.0704	0.0697	0.0690	0.0683	0.0676	0.0670	0.0663	0.0657	0.0651	0.0645	0.0639	0.0633	0.0627
25.5	0.0736	0.0728	0.0720	0.0712	0.0705	0.0698	0.0690	0.0684	0.0677	0.0670	0.0663	0.0657	0.0651	0.0645	0.0638	0.0632	0.0626	0.0621	0.0615
25.0	0.0721	0.0713	0.0706	0.0698	0.0691	0.0684	0.0677	0.0670	0.0663	0.0657	0.0650	0.0644	0.0638	0.0632	0.0626	0.0620	0.0614	0.0609	0.0603
24.5	0.0707	0.0699	0.0692	0.0684	0.0677	0.0670	0.0663	0.0657	0.0650	0.0644	0.0637	0.0631	0.0625	0.0619	0.0613	0.0608	0.0602	0.0597	0.0591
24.0	0.0692	0.0685	0.0677	0.0671	0.0664	0.0657	0.0650	0.0643	0.0637	0.0631	0.0624	0.0618	0.0612	0.0607	0.0601	0.0595	0.0590	0.0584	0.0579
23.5	0.0678	0.0671	0.0663	0.0657	0.0650	0.0643	0.0636	0.0630	0.0624	0.0618	0.0611	0.0606	0.0600	0.0594	0.0588	0.0583	0.0577	0.0572	0.0567
23.0	0.0663	0.0656	0.0649	0.0643	0.0636	0.0629	0.0623	0.0617	0.0610	0.0604	0.0598	0.0593	0.0587	0.0581	0.0576	0.0570	0.0565	0.0560	0.0555
22.5	0.0649	0.0642	0.0635	0.0629	0.0622	0.0616	0.0609	0.0603	0.0597	0.0591	0.0585	0.0580	0.0574	0.0569	0.0563	0.0558	0.0553	0.0548	0.0543
22.0	0.0635	0.0628	0.0621	0.0615	0.0608	0.0602	0.0596	0.0590	0.0584	0.0578	0.0572	0.0567	0.0561	0.0556	0.0551	0.0546	0.0540	0.0536	0.0531

Calculated from formula $d = \frac{1.327}{(460 + T)} \times B$.

TABLE 3.—Temperature of dewpoint, in degrees Fahrenheit¹ (Pressure = 29.0 inches)

Air temperature <i>t</i>	Vapor pressure <i>e</i>	Depression of wet-bulb thermometer (<i>t-t'</i>)													
		1.0	2.0	3.0	4.0	5.0	6.0	7.0	8.0	9.0	10.0	11.0	12.0	13.0	14.0
20	0.103	17	13	8	2	-5	-18								
21	.108	18	14	10	4	-3	-14	-42							
22	.113	19	15	11	6	-1	-10	-29							
23	.118	20	16	12	8	+1	-7	-22							
24	.124	21	18	14	9	3	-4	-17							
25	.130	22	19	15	11	5	-2	-12	-36						
26	.136	23	20	16	12	7	±0	-9	-26						
27	.143	24	21	18	14	9	+3	-5	-19						
28	.150	25	22	19	15	11	5	-2	-14	-45					
29	.157	26	24	20	17	12	7	±0	-9	-29					
30	.164	27	25	22	18	14	9	+3	-5	-20					
31	.172	29	26	23	20	16	11	5	-2	-14	-50				
32	.180	30	27	24	21	17	13	8	+1	-9	-29				
33	.187	31	28	25	22	19	15	10	3	-5	-20				
34	.195	32	29	27	24	20	16	12	6	-2	-14	-50			
35	.203	33	30	28	25	22	18	14	8	+1	-8	-28			
36	.211	34	31	29	26	23	20	15	11	4	-4	-19			
37	.219	35	32	30	27	24	21	17	13	7	-1	-12	-44		
38	.228	36	33	31	28	26	23	19	14	9	+3	-7	-25		
39	.237	37	34	32	29	27	24	21	16	12	6	-3	-16		
40	.247	38	35	33	31	28	25	22	18	14	8	+1	-10	-35	
41	.256	39	37	34	32	29	26	23	20	16	11	4	-5	-21	
42	.266	40	38	35	33	30	28	25	21	17	13	7	-1	-13	-59
43	.277	41	39	36	34	31	29	26	23	19	15	10	+3	-7	-28
44	.287	42	40	38	35	32	30	27	24	21	17	12	6	-2	-17
45	.298	43	41	39	36	34	31	29	26	22	19	14	8	+2	-9
46	.310	44	42	40	37	35	32	30	27	24	20	16	11	5	-4
47	.322	45	43	41	39	36	34	31	28	25	22	18	13	8	±0
48	.334	46	44	42	40	37	35	32	30	27	23	20	15	10	+4
49	.347	47	45	43	41	39	36	34	31	28	25	21	17	13	7
50	.360	48	46	44	42	40	37	35	32	29	27	23	19	15	9
51	.373	49	47	45	43	41	39	36	34	31	28	25	21	17	12
52	.387	50	48	46	44	42	40	37	35	32	29	26	23	19	14
53	.402	51	49	47	45	43	41	39	36	34	31	28	24	21	16
54	.417	52	50	49	47	44	42	40	38	35	32	29	26	23	19
55	.432	53	52	50	48	46	43	41	39	36	34	31	28	24	21
56	.448	54	53	51	49	47	45	43	40	38	35	32	29	26	23
57	.465	55	54	52	50	48	46	44	42	39	36	34	31	28	24
58	.482	56	55	53	51	49	47	45	43	40	38	35	32	29	26
59	.499	57	56	54	52	50	48	46	44	42	39	37	34	31	28
60	.517	58	57	55	53	51	49	47	45	43	41	38	35	32	29
61	.536	59	58	56	54	52	51	49	46	44	42	39	37	34	31
62	.555	60	59	57	55	54	52	50	48	46	43	41	38	35	32
63	.575	61	60	58	56	55	53	51	49	47	45	42	40	37	34
64	.595	62	61	59	58	56	54	52	50	48	46	44	41	38	36
65	.616	63	62	60	59	57	55	53	51	49	47	45	43	40	37
66	.638	64	63	61	60	58	56	54	53	51	48	46	44	42	39
67	.661	65	64	62	61	59	57	56	54	52	50	48	45	43	40
68	.684	67	65	63	62	60	58	57	55	53	51	49	47	44	42
69	.707	68	66	64	63	61	60	58	56	54	52	50	48	46	43
70	.732	69	67	66	64	62	61	59	57	55	53	51	49	47	45
71	.757	70	68	67	65	63	62	60	58	57	55	53	51	49	46
72	.783	71	69	68	66	65	63	61	60	58	56	54	52	50	48
73	.810	72	70	69	67	66	64	62	61	59	57	55	53	51	49
74	.838	73	71	70	68	67	65	64	62	60	58	56	54	53	50
75	.866	74	72	71	69	68	66	65	63	61	60	58	56	54	52
76	.896	75	73	72	70	69	67	66	64	62	61	59	57	55	53
77	.926	76	74	73	71	70	68	67	65	64	62	60	58	56	54
78	.957	77	75	74	72	71	69	68	66	65	63	61	59	58	56
79	.989	78	76	75	73	72	70	69	67	66	64	62	61	59	57
80	1.022	79	77	76	75	73	72	70	69	67	65	64	62	60	58

¹ Marvin, C. F., Psychrometric tables: U.S. Weather Bureau Bull. 235, 1915.

FUNDAMENTALS OF AIRFLOW

The principles of airflow are:

1. Airflow in a mine is induced by pressure differences between intake and exhaust openings.
2. The pressure difference is caused by imposing some form of pressure at one point or a series of points in the ventilating system.
3. The pressure created must be great enough to overcome frictional resistance and shock losses.
4. Passageways, both intakes and returns, must be provided to conduct the airflow.
5. Air always flows from a point of higher to lower pressure.
6. Airflow follows a square-law relationship between volumes and pressures, that is, twice the volume requires four times the pressure.
7. Mine-ventilating pressures, with respect to atmospheric pressures, may be either positive (blowing) or negative (exhausting).
The common method of measuring ventilating pressures producing circulation are either equivalent feet of air column or equivalent inches of water. In most calculations, pressures must be reduced to inches of water, where 1 inch of water equals a pressure of 5.2 p.s.f.
8. The pressure drop for each split leaving from a common point and returning to a common point will be the same regardless of the air quantity flowing in each split.

PRESSURE LOSSES

Pressure losses are divided into two separate groups:

1. Friction pressure losses caused by the resistance of the walls on the airstream. Friction losses therefore depend upon conditions and roughness of individual wall surfaces and velocity of the air.
2. Shock pressure losses caused by abrupt changes in the velocity of air movement. Shock losses therefore

are the result of changes in air direction or of airway area, obstructions, and regulation.

All formulas for pressure losses include an empirical factor, the value of which varies with conditions and is determined by actual experiment. This empirical factor, commonly called *K* (the coefficient of friction), unless approximately correct for the conditions, will give erroneous results.

Table 4 lists the Bureau of Mines schedule of friction factors for mine airways.

The common pressure-loss formula for mine ventilation is:

$$P = \frac{KLOV^2}{A} \text{ at standard density of } 0.075 \text{ p.c.f.}$$

where *P* is the pressure loss, pounds per square foot,

- K* is the friction factor,
- L* is the length of airway in feet,
- O* is the perimeter of the airway feet,
- V* is the velocity, feet per minute,
- A* is the cross-sectional area of the airway in square feet.

To change the pressure loss *P*, pounds per square foot, to *H*, pressure loss in inches water, the formula is divided by 5.2 and becomes $H = \frac{KLOV^2}{5.2A}$. The formula is changed to include the quantity of airflow as follows: The quantity of airflow *q* is equal to the velocity

TABLE 4.—Bureau of Mines schedule of friction factors for mine airways¹

Type of airway	Irregularities of surfaces, areas, and alinement	Values of <i>K</i> ²											
		Straight			Sinuous or curved								
		Clean (base values)	Slightly obstructed	Moderately obstructed	Slightly			Moderately			High degree		
					Clean	Slightly obstructed	Moderately obstructed	Clean	Slightly obstructed	Moderately obstructed	Clean	Slightly obstructed	Moderately obstructed
Smoothlined	Minimum	10	15	25	20	25	35	25	30	40	35	40	50
	Average	15	20	30	25	30	40	30	35	45	40	45	55
	Maximum	20	25	35	30	35	45	35	40	50	45	50	60
Sedimentary (or coal)	Minimum	30	35	45	40	45	55	45	50	60	55	60	70
	Average	55	60	70	65	70	80	70	75	85	80	85	95
	Maximum	70	75	85	80	85	95	85	95	100	95	100	110
Timbered (5-foot centers)	Minimum	80	85	95	90	95	105	95	100	110	105	110	120
	Average	95	100	110	105	110	120	110	115	125	120	125	135
	Maximum	105	110	120	115	120	130	120	125	135	130	135	145
Igneous rock	Minimum	90	95	105	100	105	115	105	110	120	115	120	130
	Average	145	150	160	155	160	165	160	165	175	170	175	185
	Maximum	195	200	210	205	210	220	210	215	225	220	225	235

¹ McElroy, G. E., Engineering Factors in the Ventilation of Metal Mines: Bureau of Mines Bull. 385, 1935, p. 43.
² All values of *K* are for air weighing 0.075 p.c.f. Values in table 4 are expressed in whole numbers but must be multiplied by 10⁻¹⁰ to obtain the proper *K* value.

times the area ($q=VA$); V therefore equals $\frac{q}{A}$, and substituting this in formula it now becomes $H=\frac{KLOq^2}{5.2A^3}$.

This formula is in general use; however, it is difficult to use because the value of K (friction factor) is usually expressed in decimals, such as (100×10^{-10}) or 0.0000000100. Changing the value of q by dividing it by 100,000, greatly simplifies the formula and makes it much easier

to use. Now $H=\frac{KLO}{5.2A^3} \times \frac{q^2}{(100,000)^2} \times (100,000)^2$;

q now becomes Q , the air quantity divided by 100,000, and the value of K , for example, can be changed from 0.0000000100 to [0.0000000100 $\times (100,000)^2=100$], the easily used whole number given in table 4, when Q is expressed as the decimal part of 100,000.

For general and easy application, the formula can be reduced still further, and R the resistance factor of the airway substituted for the $\frac{KLO}{5.2A^3}$, now making the formula $H=RQ^2$.

where H is the pressure loss in inches water, R is the resistance factor of airway or mine,

Q is the quantity of flow, c.f.m., expressed in units of 100,000.

When working with air densities other than standard, correction must be made for density variations, and the formula becomes

$$H=RQ^2 \times \frac{d}{0.075}$$

where

d =density of the air.

This formula, $H=RQ^2$, is simple to use, and once the individual is familiar with it, it can be used practically for all calculations, as will be shown by subsequent examples.

PARALLEL FLOW IN AIRWAYS

The advantage of multiple entries, both intake and return, to improve ventilation efficiencies is understood by most mining engineers. Actual comparison of pressure losses between single and multiple entries can be shown from

the formula $R=\frac{KLO}{5.2A^3}$. Assuming that addi-

tional entries are of similar size, area, length, and friction factor, by doubling the entries the

new resistance factor R^2 becomes $\frac{KL}{5.2} \times \frac{2(O)}{(2A)^3}$,

since the only changes are in doubling the perimeter and area; therefore, the formula becomes:

$$R_2=\frac{KL}{5.2} \times \frac{2(O)}{8A^3}=\frac{KL}{5.2} \times \frac{O}{4A^3}=\frac{KLO}{5.2A^3} \times \frac{1}{4}$$

The resistance of two entries is therefore one-fourth that of a single similar entry.

The formula can be developed further to apply in all instances by using n to represent the number of entries.

$$R_2=\frac{KL}{5.2} \times \frac{nO}{nA^3}=\frac{KLO}{5.2A^3} \times \frac{n}{n^3}$$

$$R_2=\frac{KLO}{5.2A^3} \times \frac{1}{n^2}$$

Since the $\frac{KLO}{5.2A^3}$ or R theoretically will be the same for similar entries, the formula can be reduced to $R_2=\frac{1}{n^2}R_1$. This means that the new resistance will be in ratio to the number of entries squared, that is, $\frac{1}{\left(\frac{n_2}{n_1}\right)^2}$.

EXAMPLE: What will be the resistance changing from a single entry to four entries?

$n_1=1, n_2=4$. The ratio is $\frac{4}{1}$, or 4.

$$R_2=\frac{1}{4^2} \times R_1=\frac{1}{16} \times R_1$$

When multiple entries are used, the same simple relationship applies.

EXAMPLE: If the resistance factor for three entries is R_1 , what will be the resistance factor for five entries?

$n_1=3, n_2=5$. The ratio is $\frac{5}{3}$.

$$R_2=\frac{1}{\left(\frac{5}{3}\right)^2} \times R_1=\frac{1}{\frac{25}{9}} \times R_1=\left(\frac{9}{25} \times R_1\right)$$

EXAMPLE: If the situation were that five entries are available but two must be stopped off, the ratio would be $\frac{3}{5}$.

$$R_2=\frac{1}{\left(\frac{3}{5}\right)^2} \times R_1=\frac{1}{\frac{9}{25}} \times R_1=\left(\frac{25}{9} \times R_1\right)$$

SPLITTING AIR CURRENTS

Split ventilation is necessary for both economic and safety requirements. Dividing the mine ventilating system into multiple splits provides separate ventilating districts in the mine and permits better air control. Air splits should be taken off as near the mine intake as possible and brought together close to the return opening to reduce air quantity and pressure losses by full use of parallel flow.

Natural splits are those where the airflow divides naturally; each split handles a volume of air dependent on the pressure drop and resistance factor.

Regulated splits are those where it is necessary to control the volumes in certain low-resistance splits to cause enough air to flow into the splits of high resistance. A *regulator* is artificial resistance installed in a low-resistance split. Regulators may be small openings in stoppings controlled by slide doors or may be doors latched partly open.

Split regulation, usually established by trial and error, is used to control air quantities in working sections, to equalize splits and to control the operation. Such methods are probably the only way that variable requirements can be satisfied. When planning ventilation changes or checking ventilation efficiencies, it is desirable to know the pressure loss-air volume relationship for regulators. This relationship can be determined by the following formula:

$$A = 40 \times Q \div \sqrt{H}$$

A = area regulator opening in square feet,
 Q = air quantity, expressed in units of 100,000 c.f.m.,

H = pressure drop across regulator in inches water.

EXAMPLES: (1) What size area will be needed to pass 20,000 c.f.m. at a pressure drop of 2 inches water? (2) What will be the approximate pressure loss through a hole in a stopping 2 feet square, passing 8,000 c.f.m.?

Problem 1:

$$A = \frac{40}{\sqrt{2}} \times \left(\frac{20,000}{100,000} \right),$$

$$A = \frac{40 \times 0.2}{\sqrt{2}},$$

$$A = \frac{8}{1.414} = 5.66 \text{ sq. ft.}$$

Problem 2:

$$2 = \frac{40}{\sqrt{H}} \times \left(\frac{8,000}{100,000} \right),$$

$$\sqrt{H} = \frac{40 \times .08}{2} = 20 \times 0.08 = 1.6,$$

$$H = 1.6^2 = 2.56 \text{ inches water.}$$

To illustrate the natural airflow potential for splitting, based upon airflow fundamentals, the following simple problem is worked out (fig. 10):

A mine has three main splits, all separating at point A and joining again at point B , as shown by figure 10. All entries have the same coefficient of friction:

Split 1 is 3,200 ft. long, area = 90 sq. ft., perimeter = 40 ft.
 Split 2 is 2,400 ft. long, area = 70 sq. ft., perimeter = 35 ft.
 Split 3 is 3,600 ft. long, area = 90 sq. ft., perimeter = 40 ft.

EXAMPLE: What will be the natural splitting if the intake to point A is 150,000 c.f.m.?

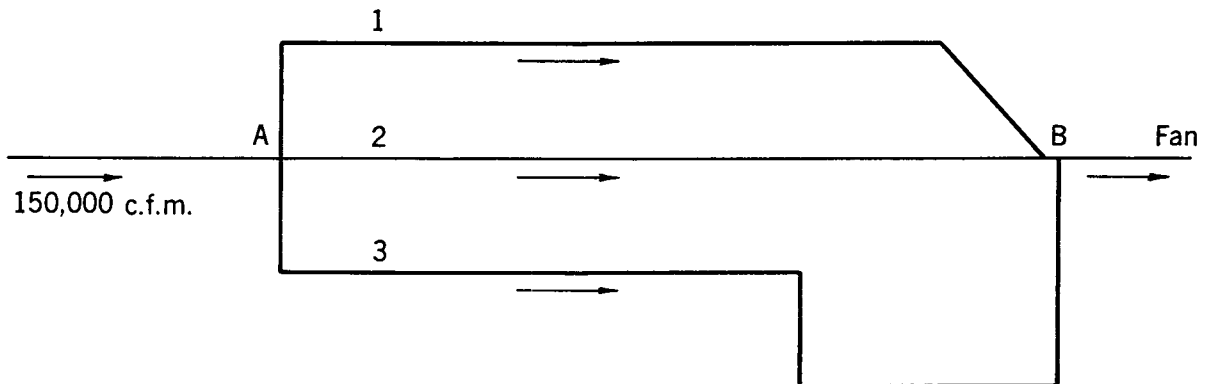

Entry 1. Length, 3,200 ft.
 Area, 90 sq. ft.
 Perimeter, 40 ft.

Entry 2. Length, 2,400 ft.
 Area, 70 sq. ft.
 Perimeter, 35 ft.

Entry 3. Length, 3,600 ft.
 Area, 90 sq. ft.
 Perimeter, 40 ft.

FIGURE 10.—Airflow With Natural Splitting.

CALCULATIONS

The basic formula $H = \frac{KLOq^2}{5.2A^3}$ applies.

$$q^2 = \frac{5.2A^3H}{KLO}$$

$$q^2 = \frac{A^3}{LO} \times \frac{5.2H}{K}$$

The pressure drop H , the conversion factor 5.2, and the coefficient of friction K , will be the same for all splits. Consequently, these can be canceled and the formula becomes:

$$q^2 = \frac{A^3}{LO}$$

Extracting the square roots and simplifying the formula, it becomes:

$$q = A\sqrt{\frac{A}{LO}}$$

This formula often is called the formula for potential air splitting. For ease with calculations, L should be expressed in units of 1,000 feet; for example, a length of 3,200 feet becomes 3.2.

$$q_1 + q_2 + q_3 = 150,000 \text{ c.f.m.},$$

$$\left. \begin{aligned} q_1 &= A_1\sqrt{\frac{A_1}{L_1O_1}} = 90\sqrt{\frac{90}{3.2 \times 40}} = 90\sqrt{\frac{9}{12.8}} \\ &= 90 \times \sqrt{.703} = 75.4 \\ q_2 &= A_2\sqrt{\frac{A_2}{L_2O_2}} = 70\sqrt{\frac{70}{2.4 \times 35}} = 70\sqrt{\frac{2}{2.4}} \\ &= 70 \times \sqrt{.833} = 63.8 \\ q_3 &= A_3\sqrt{\frac{A_3}{L_3O_3}} = 90\sqrt{\frac{90}{3.6 \times 40}} = 90\sqrt{\frac{3}{4.8}} \\ &= 90 \times \sqrt{.625} = 71.1 \end{aligned} \right\} 210.3,$$

$$\left. \begin{aligned} q_1 &= \frac{75.4}{210.3} \times 150,000 \text{ c.f.m.} \\ &= 53,800 \text{ c.f.m.} \\ q_2 &= \frac{63.8}{210.3} \times 150,000 \text{ c.f.m.} \\ &= 45,500 \text{ c.f.m.} \\ q_3 &= \frac{71.1}{210.3} \times 150,000 \text{ c.f.m.} \\ &= 50,700 \text{ c.f.m.} \end{aligned} \right\} 150,000 \text{ c.f.m.}$$

This problem illustrates free splitting and shows how approximations of airflow can be made for planning on the basis of projected airway measurements without knowing pressure values.

Problems involving regulation and ventilation changes require pressure-volume relationships for segments of the mine that will be affected. Figure 11 shows a similar simple problem but with air quantities—the pressure losses illustrated by a pressure gradient and the fan characteristic. The problem now is to regulate entries 2 and 3 so that entry 1 will carry 70,000 c.f.m. The first step is to calculate the resistance factors for each segment and split, using the formula $H = RQ^2$. $R = \frac{H}{Q^2}$ where the given quantity Q is expressed in units of 100,000. H = pressure in inches water.

Segment A-B:

$$H = 1.5 \text{ inch, } q = 150,000 \text{ c.f.m.,}$$

$$Q = 1.5,$$

$$R = \frac{1.5}{(1.5)^2} = \frac{1.5}{2.25} = 0.67.$$

Segment B-C:

Split 1:

$$H = 1.0 \text{ inch, } q = 52,500 \text{ c.f.m.,}$$

$$Q = 0.525$$

$$R = \frac{1}{(.525)^2} = \frac{1}{0.276} = 3.62.$$

Split 2:

$$H = 1.0 \text{ inch, } q = 48,000 \text{ c.f.m.,}$$

$$Q = 0.480,$$

$$R = \frac{1}{(0.480)^2} = \frac{1}{0.23} = 4.35.$$

Split 3:

$$H = 1.0 \text{ inch, } q = 49,500 \text{ c.f.m.,}$$

$$Q = 0.495,$$

$$R = \frac{1}{(0.495)^2} = \frac{1}{0.245} = 4.08.$$

Segment C-D:

$$H = 1 \text{ inch, } q = 150,000 \text{ c.f.m.,}$$

$$Q = 1.500,$$

$$R = \frac{1}{(1.5)^2} = \frac{1}{2.25} = 0.44.$$

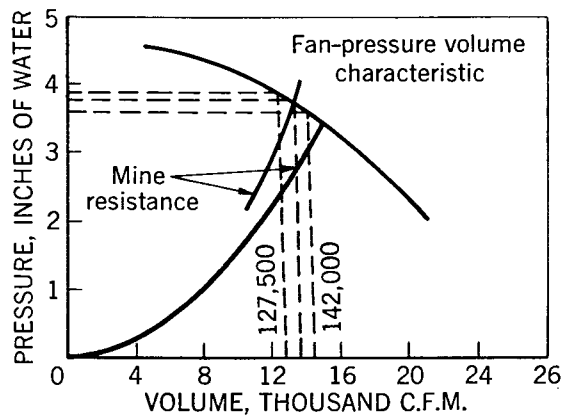
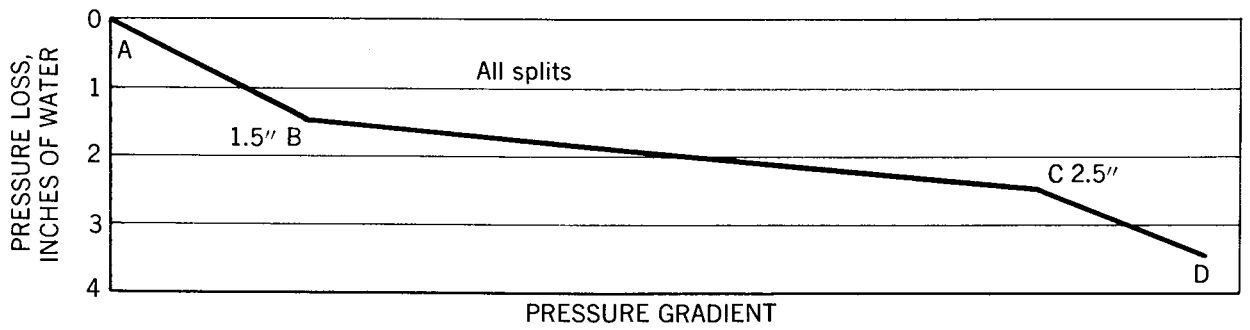
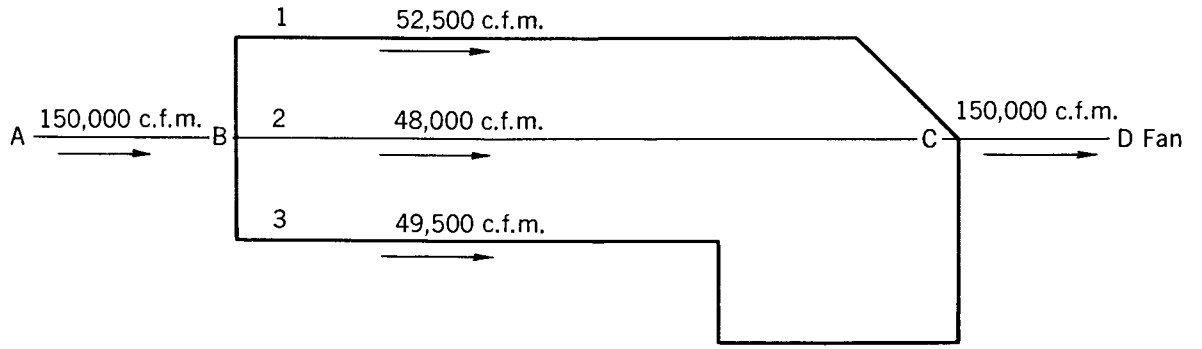

FIGURE 11.—Example of Airflow Splitting.

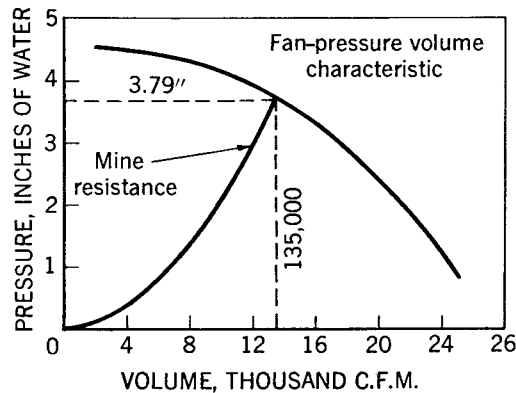
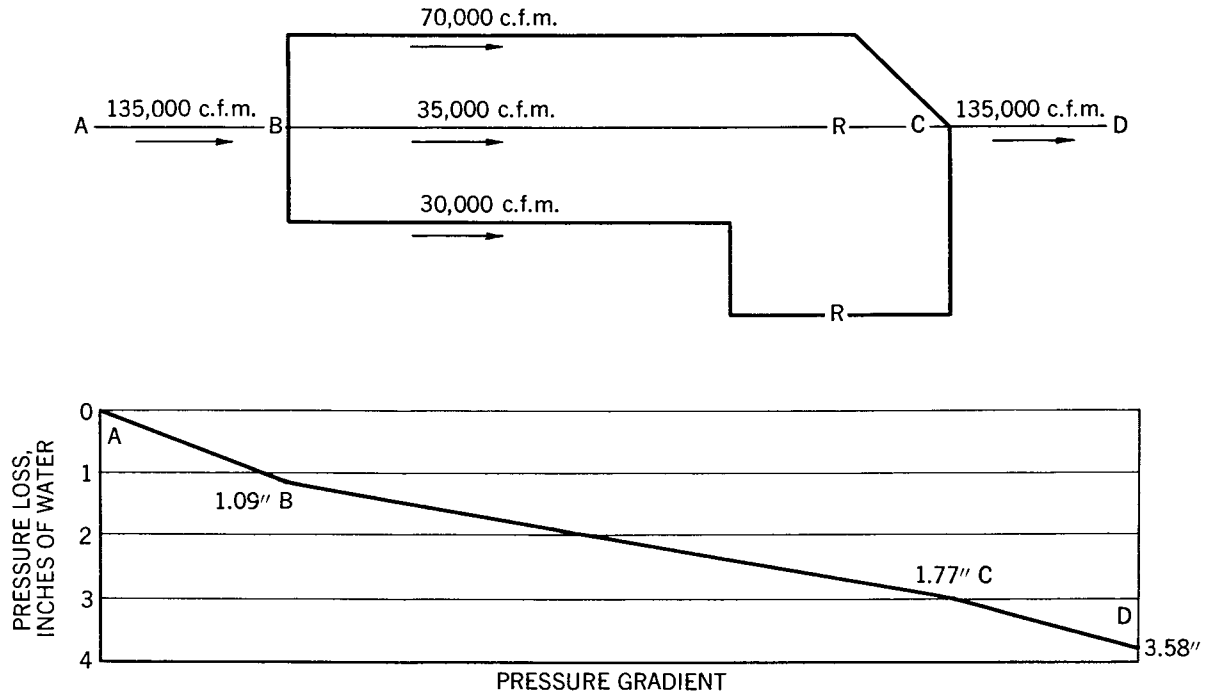

FIGURE 12.—Example of Airflow Splitting, With Regulation.

AIR LOSSES FROM LEAKAGE

Leakage losses are a serious detriment to the efficiency of a mine ventilating system. When the costs of fan installations, air shafts, overcasts, stoppings, and other ventilating equipment are compared with the small percentage of air actually reaching the working face, the importance of air leakage becomes evident.

Air leakage for operating mines in many instances is as much as 70 percent between the intake and the sum of the air volumes at the last open breakthroughs. A leakage path is simply a parallel return path to the fan.

The amount of leakage will be determined by the pressure difference between intake and return and the condition of stoppings and overcasts. The best stoppings are either brick or solid block set with mortar, anchored into the rib, roof, and floor, and plastered. The common practice of stacking hollow blocks dry and plastering the intake side to form a stopping is conducive to large leakage losses.

Figure 13 illustrates leakage losses in a main split of a large coal mine. The efficiency can be calculated as follows—splits 4 right and 8

Regulating splits 2 and 3 to cause 70,000 c.f.m. in split 1 will change the mine pressure-volume relationship, since split 1 now will have a pressure drop of more than the original 1.0 inch, owing to the increased flow against the same resistance. The new pressure losses in splits now will be:

Split 1:

$$q=70,000, \text{ and } R=3.62, \\ \text{calculated above;} \\ Q=0.70, \\ H=RQ^2=3.62 \times (0.70)^2 \\ =3.62 \times 0.49=1.77 \text{ inches water.}$$

This shows an increase of 0.77 inch water in split 1. Each split with regulation must now carry this same pressure drop.

With increased resistance of the mine system, the air volume delivered by the fan, based upon the pressure-volume characteristic, will be substantially less. To determine the amount of this reduction a trial-and-error approximation must be made.

Step 1.—Assume an air-volume reduction of 15 percent ($150,000 \times 85$ percent = 127,500 c.f.m.). Then from the fan characteristic (fig. 11) a volume of 127,500 c.f.m. will be induced at a pressure of approximately 3.92 inches water. This pressure consists of segments A-B, B-C, and C-D; Segments A-B and C-D will vary with the total quantity. Segment B-C at 70,000 c.f.m. is fixed at 1.77-inch water gage.

Step 2.—Calculate pressure drop, segments A-B and C-D. Calculating A-B, R factor = 0.67, new $q=127,500$ c.f.m., $Q=1.275$. New $H=RQ^2=0.67 \times (1.275)^2=1.09$ inches water.

Calculating C-D, R factor = 0.44, new $q=127,500$ c.f.m., $Q=1.275$. New $H=0.44 \times (1.275)^2=0.72$ inch water.

Step 3.—Sum up new pressure losses, inches water gage:

	<i>Inches</i>
A-B	1.09
B-C	1.77
C-D72
Total water gage	3.58

(See fig 12.)

Step 4.—Compare the pressure 3.58 inches with the fan characteristic (fig. 11). This is a delivered quantity of approximately 142,000 c.f.m.; so the true volume falls between 127,500 c.f.m. and 142,000 c.f.m.

Recalculating: Steps 2 and 3 at 135,000 c.f.m.: This air quantity at approximately 3.80 inches

water is accepted as within practical limits. (See fig. 12.)

After establishing that with regulation the new pressure-volume relationship would be 135,000 c.f.m. at 3.80 inches water, the size of regulators can be calculated.

The total air to be divided by splits 2 and 3 is 135,000 c.f.m., less the 70,000 c.f.m. for split 1; this equals 65,000 c.f.m., which can be split in any quantity desired. In this instance, allow 35,000 c.f.m. for split 2 and 30,000 c.f.m. for split 3.

Split 2, with 35,000 c.f.m. flowing, will have a pressure loss equal to the resistance factor $\times (0.35)^2=4.35 \times (0.35)^2=4.35 \times 0.122=0.53$ inch water.

Split 3, with 30,000 c.f.m. flowing, will have a pressure loss equal to the resistance factor $\times (0.30)^2=4.08 \times (0.30)^2=0.37$ inch water.

The required regulations for split 2 equals the pressure loss through split 1, less the pressure loss through split 2 with 35,000 c.f.m., that is, 1.77—0.53. The result: 1.24 inches water pressure must be consumed through regulation.

The formula $A=\frac{40Q}{\sqrt{H}}$ applies, where $H=1.24$ inches, $Q=(0.35)$.

$$A=\frac{40 \times 0.35}{\sqrt{1.24}}=\frac{14}{\sqrt{1.24}}=12.6 \text{ sq. ft.}$$

Split 3, calculated the same way:

$$H=1.77-0.37=1.40, \quad q=30,000, \quad Q=0.30,$$

$$A=\frac{40 \times 0.30}{\sqrt{1.40}}=\frac{12}{1.18}=10.2 \text{ sq ft.}$$

(Calculation should be checked for errors.)

Segment A-B: $q=135,000$ c.f.m., $R=0.67$,
 $H=0.67 \times (1.35)^2=1.22$ inches water.

Segment B-C: = 1.77, previously calculated.

Segment C-D: $q=135,000$ c.f.m., $R=0.44$,
 $H=0.44 \times (1.35)^2=0.80$ inch water.

The total pressure of the system then equals 1.22 plus 1.77 plus 0.80 equals 3.79 inches water.

This checks reasonably close with the fan characteristic for 135,000 c.f.m.; therefore, calculations are assumed to be correct. Should more air than 135,000 c.f.m. be required, with 70,000 for split 1, the fan must be altered either by changing the blade position or increasing the speed. Figure 12 illustrates the completed airflow pattern and pressure gradient.

right, 60-percent efficient in by the overcast;
total intake, 130,000 c.f.m.:

	<i>c.f.m. through last breakthrough</i>
4 right split: 30,000 c.f.m. $\times 0.60$	18,000
8 right split: 25,000 c.f.m. $\times 0.60$	15,000
Development.....	10,000
Total effective air.....	43,000

$43,000 \div 130,000 \times 100 = 33$ -percent efficiency,
67-percent loss.

In this study the large leakage losses on the mains were due to the high-pressure differential between intake and return. Five center entries were used for intake and seven entries as returns.

MECHANICAL VENTILATION

The application of fans to induce airflow is common to most coal mines. Modern mine fans are the axial-flow type; however, there are many centrifugal fans still in use. The general fan laws are the same for either axial flow or centrifugal fans. The only differences are individual characteristics of power, pressure, and air volumes.

FAN LAWS

1. Air quantity varies directly as fan speed; quantity is independent of air density (twice the volume requires twice the speed).
2. Pressures induced vary directly as fan speed squared, and directly as density (twice the volume develops four times the pressure).
3. The fan-power input varies directly as the fan speed cubed and directly as the air density (twice the volume requires eight times the power).
4. The mechanical efficiency of the fan is independent of the fan speed and density.

SELECTION OF FANS

The performance of a fan in a ventilating system is determined by its characteristic curve and the mine resistance if acting alone on the system; and by its characteristic curve, characteristics of other pressure sources, and the resistance of individual zones of influence if acting in combination with other pressure sources. Fan characteristic curves are a matter of design, which is controlled by the manufacturer. The resistance of the mine is a matter of layout and maintenance of the ventilating network and is controlled by the mine operator. Figure 14 illustrates the relationship of the fan characteristic and mine resistance.

The amount of airflow induced in a mine will depend on the fan characteristic and mine resistance. The pressure (H) required to pass a quan-

tity (q) through a mine or segment of a mine is expressed by the common formula $H=RQ^2$ where R , the resistance factor, may be calculated from known pressure losses or from the common formula previously discussed.

$R = \frac{KLO}{5.2A^3}$, and Q is the air quantity expressed in units of 100,000 c.f.m.

Mine fans are available that will suit most conditions of mine resistance and desired volume relationships. Modern fans are built with variable pitch blades that permit a wide range of application for the single fan. Figure 15 compares the characteristic curves for a fan operating at different speeds and blade settings. The various blade settings permit the same fan to operate through a wide range of mine-resistance relationships.

All fan-performance data are based upon a standard density of 0.075 p.c.f. At altitudes where the air density is substantially less than standard, corrections must be applied on the basis of the true density. Fan law No. 2 states that pressures vary directly with density; therefore, pressures can be corrected from the ratio $\frac{d}{0.075}$, where d is the actual air density.

The most practical and convenient method of correcting fan-performance curves is to establish an average density for the fan elevation and to place the corrected pressures directly on the chart. For example, if the average density is determined to be 0.060 p.c.f., the correction ratio will be $0.060 \div 0.075 = 0.80$. Figure 16 shows the corrected fan-performance curve. As can be seen, the same fan at different elevations will operate at different pressures for the same air quantity.

The efficiency of the fan is the relationship of the power output, divided by the power input. The power input is the actual horsepower used to drive the fan rotor and equals the measured motor horsepower, less any shaft or belt losses.

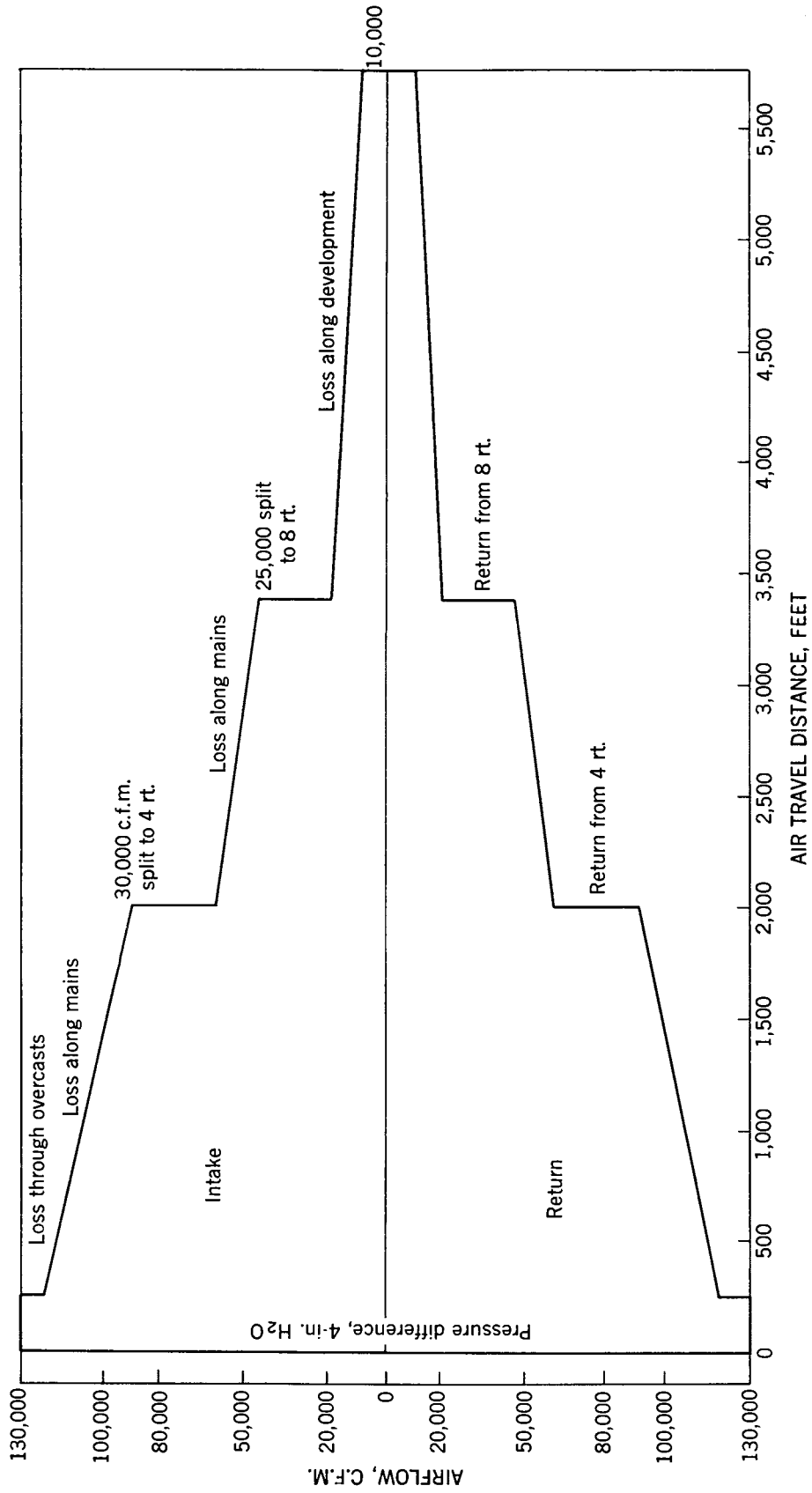

FIGURE 13.—Illustration of Air-Leakage Losses.

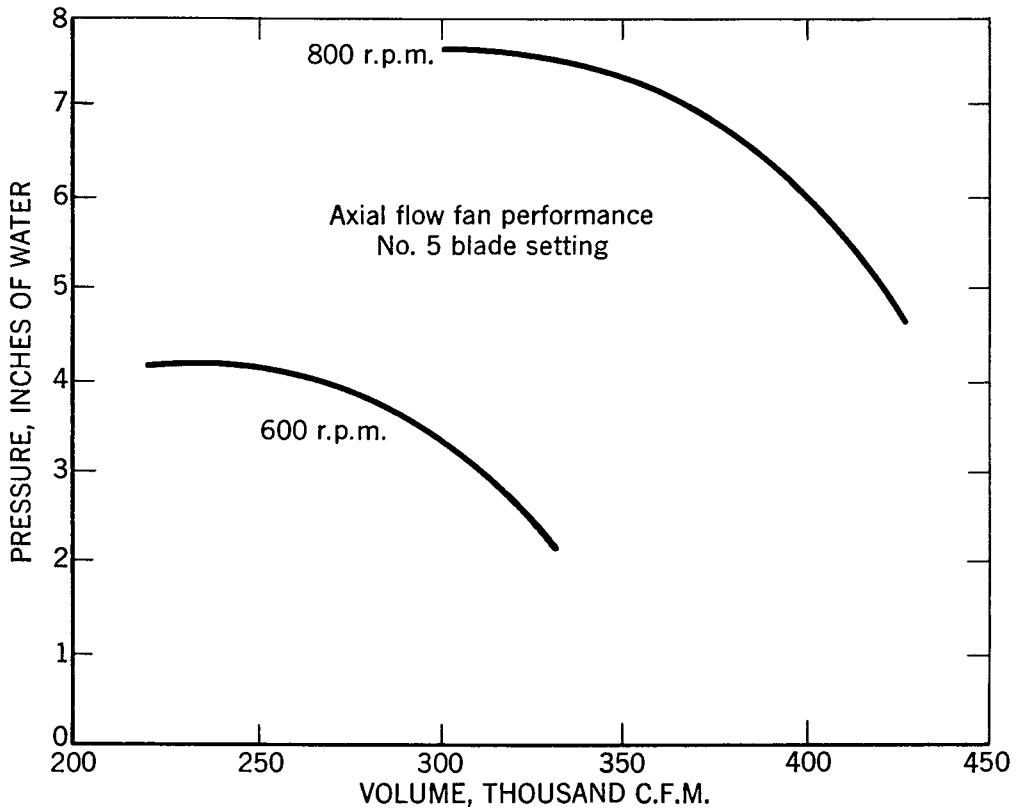
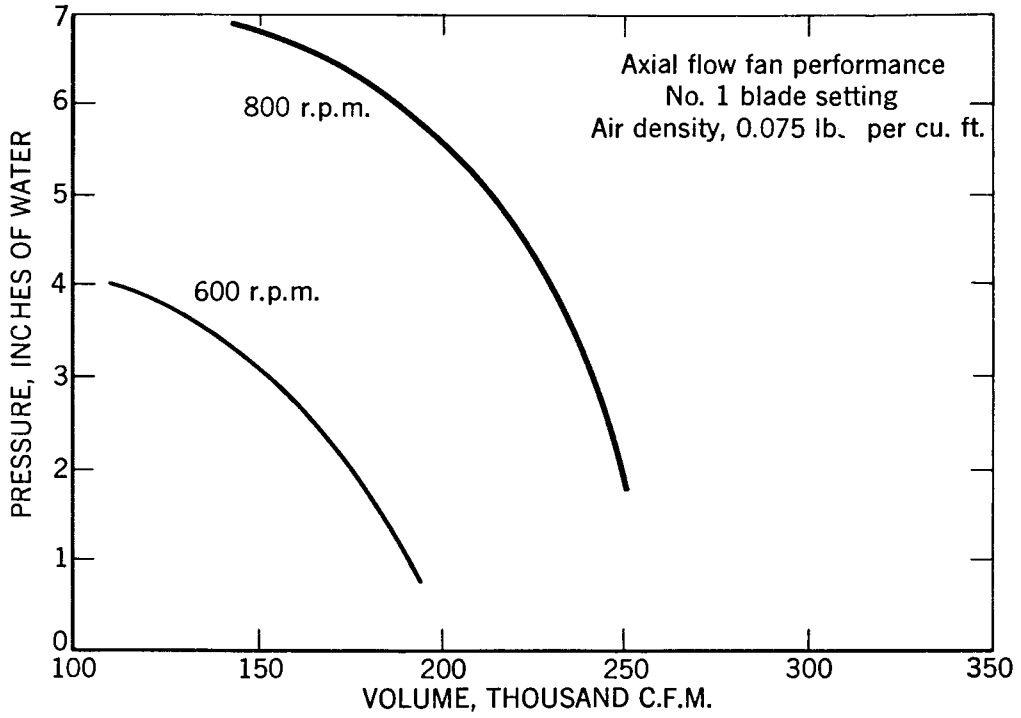

FIGURE 15.—Comparison of Characteristic Curves for Fan Operating at Different Speeds and Blade Settings.

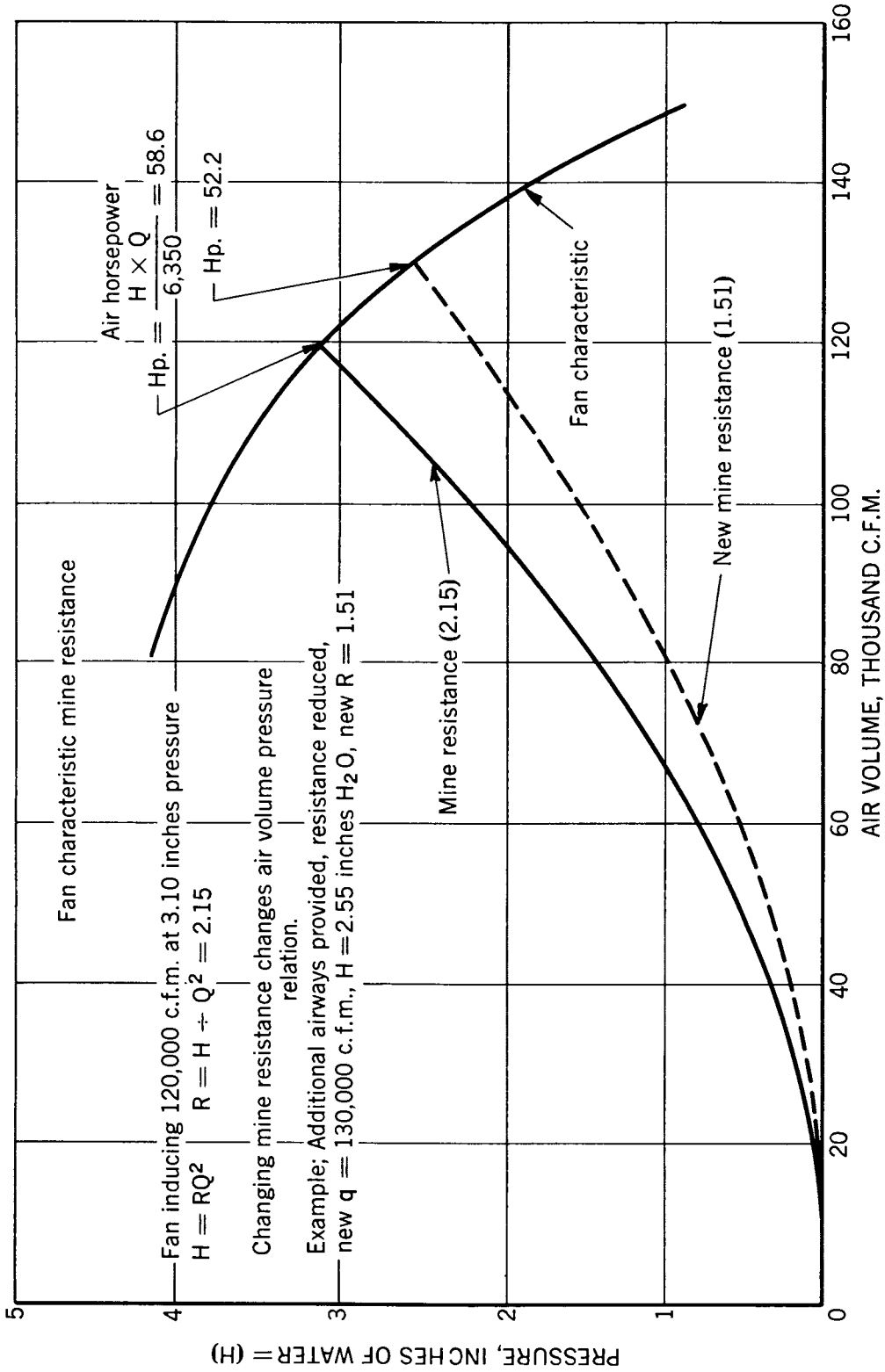

FIGURE 14.—Relationship Between Fan Characteristic and Mine Resistance.

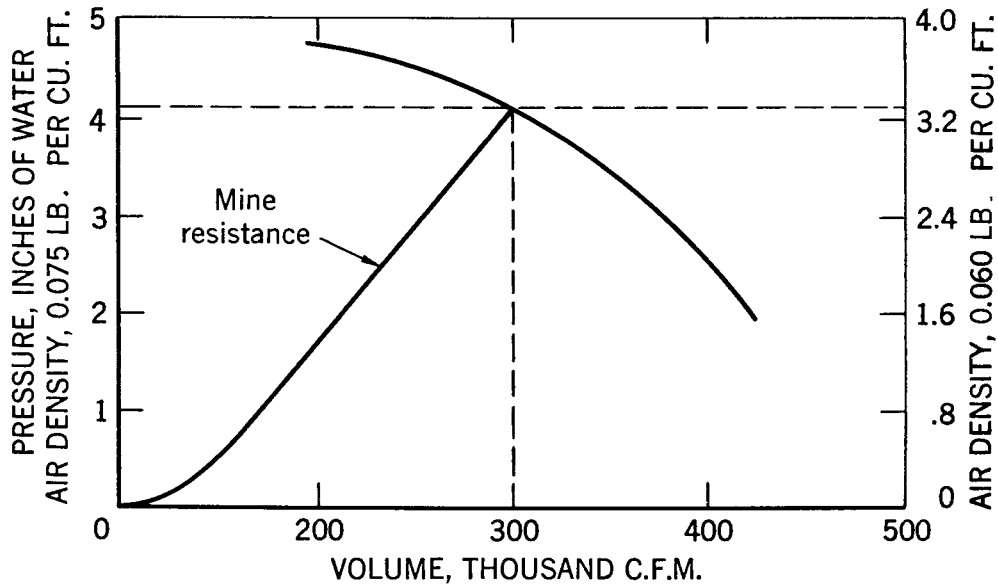

FIGURE 16.—Corrected Fan-Performance Curve at Average Local Air Density.

The power output of the fan is measured in air horsepower, which is the total fan pressure (P) in pounds per square foot times the air quantity in cubic feet per minute, divided by 33,000. Since 33,000 ft.-lb. equals 1 hp., air horsepower equals $\frac{P \times q}{33,000}$. For convenience, since most measurements are in inches of water, the pressure P is changed to H (pressure in inches of water); and since $H = \frac{P}{5.2}$, $P = H \times 5.2$. Substituting this in the formula, air horsepower = $\frac{H \times 5.2 \times q}{33,000}$. Simplifying it further, air horsepower = $\frac{H \times q}{6,350}$ for practical applications.

Air horsepower, therefore, is based upon air quantity and pressure measurements, which have been discussed previously. Accuracy limits also were discussed.

FAN TESTS

To determine accurately the efficiency of a fan installation and to check the pressure-volume characteristic curve requires a test using instruments to measure air volumes, air-density pressures, speed, and electrical-input data.

Table 5 gives the field data and calculated results of a 5-position, 20-point fan test of a 6-foot axial-flow fan. Velocity measurements were made with a pitot tube using the measurements shown in figure 10 and were always positive. Compiling the data and making calculations are relatively simple. This illustration shows how the velocity pressures (VP) must be handled by extracting square roots before they are averaged. The fan static pressure, since this is an exhausting fan, is negative and equals the total pressure (TP) less (VP) the velocity pressure. $(SP) = [TP - (+VP)] = -3.85 - 2.18 = -6.03$ inches water.

TABLE 5.—*Fan-test data sheet, fan exhausting*

Fan	Mfg.	Model No.	Date					
Type	Blade position	Observers						
<i>VP</i> = Velocity pressure measured, inches water, always positive.			<i>TP</i> = Total pressure measured, inches water.					
Pitot position	Observed pitot readings in quadrant							
	A		B		C		D	
	<i>VP</i>	<i>TP</i>	<i>VP</i>	<i>TP</i>	<i>VP</i>	<i>TP</i>	<i>VP</i>	<i>TP</i>
1.....	2.24	-3.91	2.19	-3.95	2.20	-3.94	2.27	-3.88
2.....	2.20	-3.86	2.22	-3.83	2.18	-3.90	2.21	-3.85
3.....	2.18	-3.90	2.18	-3.88	2.11	-3.92	2.16	-3.92
4.....	2.15	-3.75	2.20	-3.70	2.17	-3.72	2.19	-3.71
5.....	2.10	-3.85	2.15	-3.80	2.12	-3.82	2.11	-3.84
Organized data								
Pitot position	Square root of <i>VP</i>				Average \sqrt{VP}	Final average	Average <i>TP</i>	Final average
	<i>VP</i>	<i>TP</i>	<i>VP</i>	<i>TP</i>				
1.....	1.497	1.480	1.483	1.507	1.492		-3.92	
2.....	1.483	1.490	1.476	1.487	1.484		-3.86	
3.....	1.476	1.476	1.453	1.470	1.469		-3.91	
4.....	1.466	1.483	1.473	1.480	1.475		-3.72	
5.....	1.449	1.466	1.456	1.453	1.456		-3.83	
					7.376	1.475	-19.24	-3.85

CALCULATIONS

Area at measuring point: 24.75 sq. ft.

Air density: 0.075 lb./cu. ft.

Air horsepower: $\frac{146,000 \times 3.85}{6,350} = 88.5$ hp. $V = 4,000 \times 1.475 = 5,900$ ft./min. $q = 5,900 \times 24.75 = 146,000$ c.f.m. $VP = (1.475)^2 = 2.18$ H₂O.

SUPPLEMENTARY FAN DATA

Motor: 3-phase, 440 volt.

Rating: 150 hp.

Amperes: 150 measured.

Power factor: 0.85 measured.

r.p.m.: 1,175 rated.

Fan Drive: V-belt, r.p.m. 1,060.

$$\text{hp.} = \frac{\text{volts} \times \text{amperes} \times \text{power factor} \times \sqrt{3}}{746}$$

$$\text{Calculated input horsepower: hp.} = \frac{440 \times 150 \times 0.85 \times 1.732}{746} = 130.$$

$$\text{Overall mechanical efficiency: } \frac{\text{air hp.}}{\text{input hp.}} = \frac{88.5}{130} = 68 \text{ percent.}$$

These data do not include belt losses that should be considered if the efficiency of the fan only is to be determined.

Assuming a 5-percent loss due to belt slippage and friction, the actual input horsepower to the

fan equals 130 times 0.95 or 123.50; actual fan efficiency equals $\frac{88.5}{123.5}$, or 72 percent.

For comparison, the following data are given showing similar tests for a fan, blowing:

TABLE 6.—*Fan-test data sheet, fan blowing*

Pitot position	Observed pitot readings in quadrant							
	A		B		C		D	
	VP	TP	VP	TP	VP	TP	VP	TP
1.....	2.24	6.15	2.19	6.14	2.20	6.14	2.27	6.15
2.....	2.20	6.06	2.22	6.05	2.18	6.08	2.21	6.06
3.....	2.18	6.08	2.18	6.06	2.11	6.03	2.16	6.08
4.....	2.15	5.90	2.20	5.90	2.17	5.89	2.19	5.90
5.....	2.10	5.95	2.15	5.95	2.12	5.94	2.11	5.95

Pitot position	Organized data						Remarks
	Square root of VP				Average \sqrt{VP}	Average TP	
	1	2	3	4	5	6	
1.....	1.497	1.480	1.483	1.507	1.492	6.15	Average VP=2.18 inches water
2.....	1.483	1.490	1.476	1.487	1.484	6.06	
3.....	1.476	1.476	1.453	1.470	1.469	6.06	
4.....	1.466	1.483	1.473	1.480	1.476	5.90	Average TP=6.02 inches water
5.....	1.449	1.466	1.456	1.453	1.456	5.95	

$SP = TP - VP = 6.02 \text{ inches} - 2.18 \text{ inches} = 3.84 \text{ inches H}_2\text{O}.$

Comparing fan pressures: From these tests it can be seen that the total pressure of an exhaust fan compares with the static pressure of a fan under a similar condition when blowing.

This comparison appears confusing, since pressure differences, negative and positive, measured directly against atmospheric pressures do not appear consistent with the total-pressure differences generated by the fan. Figure 17 shows the pressure changes in ventilating systems for both blowing and exhausting fans.

FANS IN SERIES

Fans operating in series are those operating on the same flow circuit, each handling the total flow of the circuit and each generating a part of the total pressure required to balance the pressure losses of the circuit. Any number of fans can be used. The advantage of fans operating in series is that where resistance to flow is high more efficient distribution and better operating conditions may be obtained.

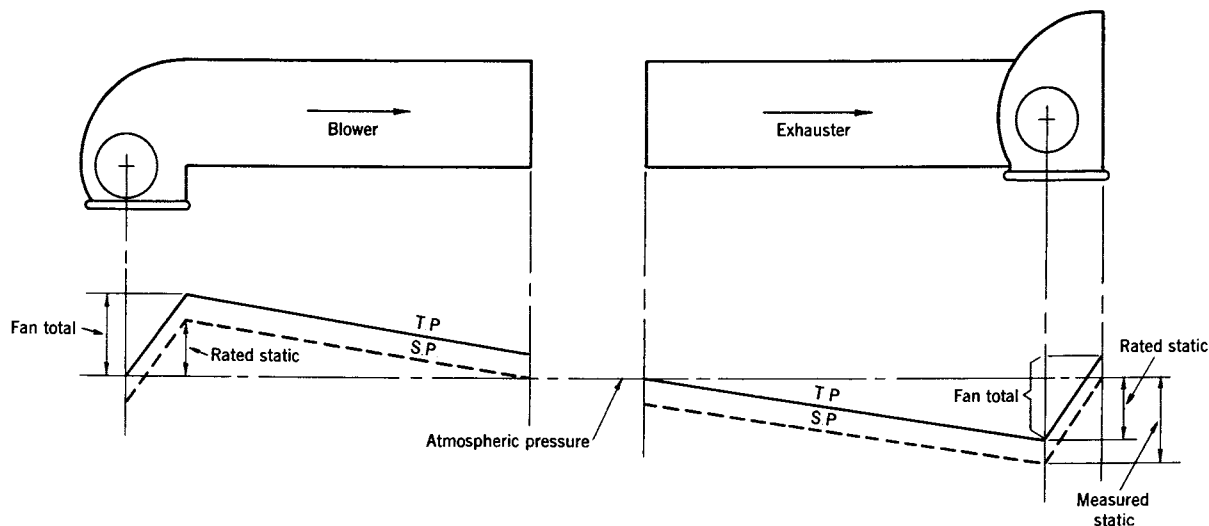

FIGURE 17.—Pressure Changes in a Ventilating System for Blowing and Exhausting Fans.

The flow conditions for series operations are determined by mine resistance and the combined pressure characteristic of the fans. The combined pressure characteristic is obtained by plotting the sum of the pressures for the same quantity.

Figure 18 shows the combined characteristics of two identical fans operating in series. With a single fan, the quantity was 145,000 c.f.m. at 4 inches pressure; with the fans combined, the quantity increased to 183,000 c.f.m. at a pressure of 6.6 inches, divided equally at 3.3 inches for each fan. Figure 19 shows the combined characteristics of two different fans operating in series. The total air volume delivered is 162,500 c.f.m. at 6.6 inches pressure. The pressure will be supplied as follows: 1.9 inches by fan A and 4.7 inches by fan B. Unless the two fans are properly selected for the work to be done in series operation, they will not operate together at maximum efficiency, and the results will be disappointing. The mine-

resistance curve must intercept the combined characteristic curve of both fans.

FANS IN PARALLEL

Fans may be used in parallel to increase the air volume against changed mine resistance. As a mine is developed and more air is needed, a common practice is to install an available fan in parallel with the operating fan.

Fans may be placed together to operate on the same airway or they may be on separate airways. When operating on the same airway, they act together on the total flow. The primary condition is that the pressure generated by each fan must equal the pressure loss sustained by the total volume they produce. The combined performance characteristic of fans acting in parallel at the same point in the system is obtained by plotting the sum of the quantities handled at the same pressures against the pressures. The intersection of the

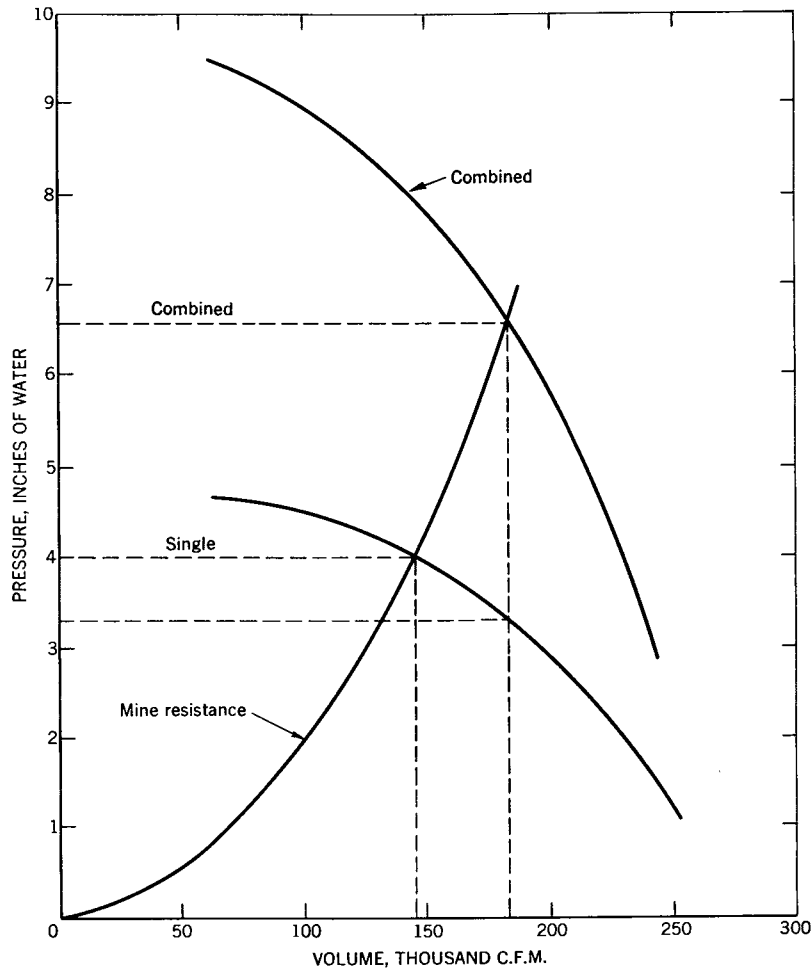

FIGURE 18.—Combined Characteristics of Two Identical Fans Operating in Series.

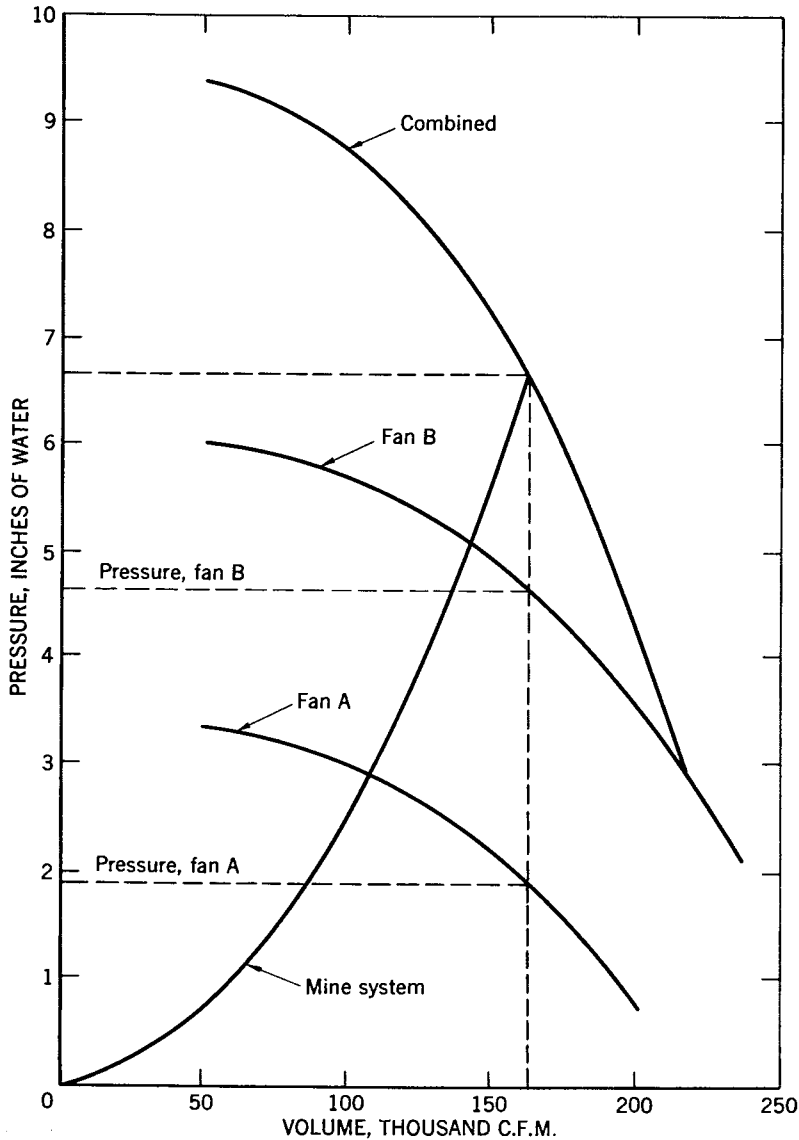

FIGURE 19.—Combined Characteristics of Two Different Fans Operating in Series.

system and the combined fan characteristics determine the pressure; and, since the pressure must be the same for both fans, this pressure determines the relative quantities that each fan will produce.

If the mine-resistance curve does not intersect the combined characteristics, the higher pressure fan will handle more air alone than the two fans together, and if an attempt is made to operate them in parallel, the high-pressure fan will reverse air through the low-pressure fan.

Fans that have steeply sloping characteristics act together in parallel. Those fans that have characteristics combining a comparatively flat and steeply sloping part must be operating on the steeply sloping part of the performance

range. Otherwise, sudden changes in the system resistance could cause the higher pressure fan to assume all the load.

A common method of installing fans in parallel is to place them on separate airways. Where the resistances of the separate airways are comparatively large, little operating trouble is experienced. However, when the separate airway resistance is small, it is difficult to determine the resistance against which the fans must operate. Consequently, the characteristics of the separate, as well as of the combined, airways must be considered.

Figure 20 illustrates results with two identical fans operating in parallel. Compared with a single fan, pressures and quantities have

increased. Each fan is now operating at a pressure of 3.85 inches at a combined air quantity of 245,000 c.f.m. Each fan theoretically will induce one-half of the total quantity. This will not be so in actual

practice, since fan installations and mechanical arrangements will vary slightly.

Figure 21 illustrates results with two different fans operating in parallel at the same pressures; each fan contributes different quantities to

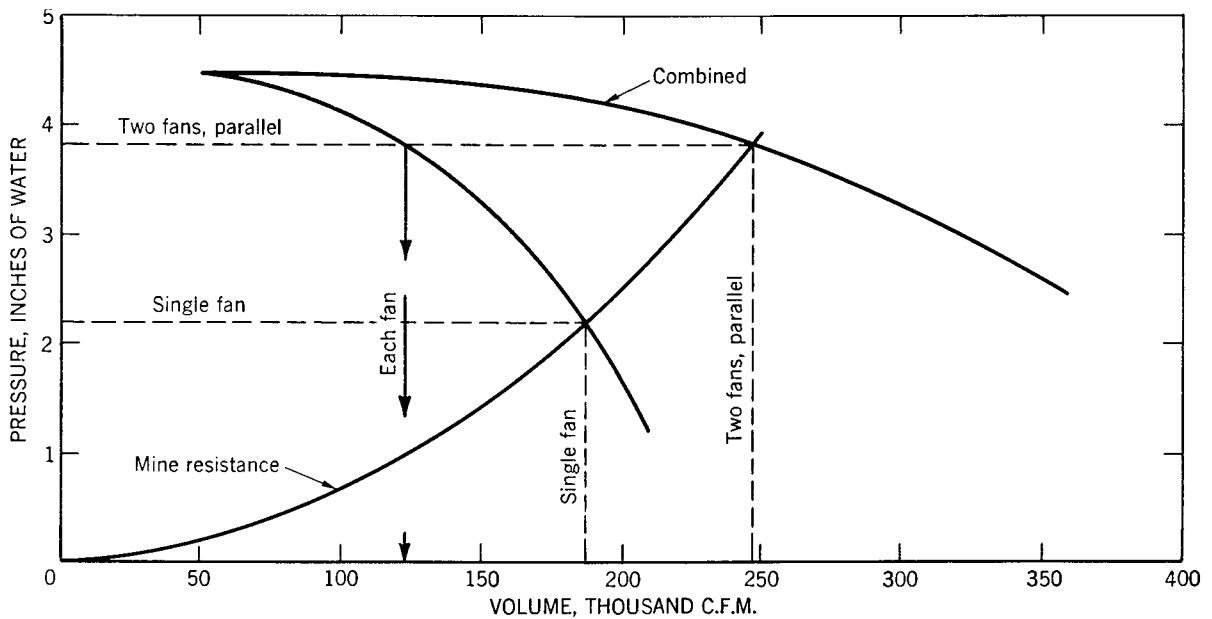

FIGURE 20.—Two Identical Fans Operating in Parallel.

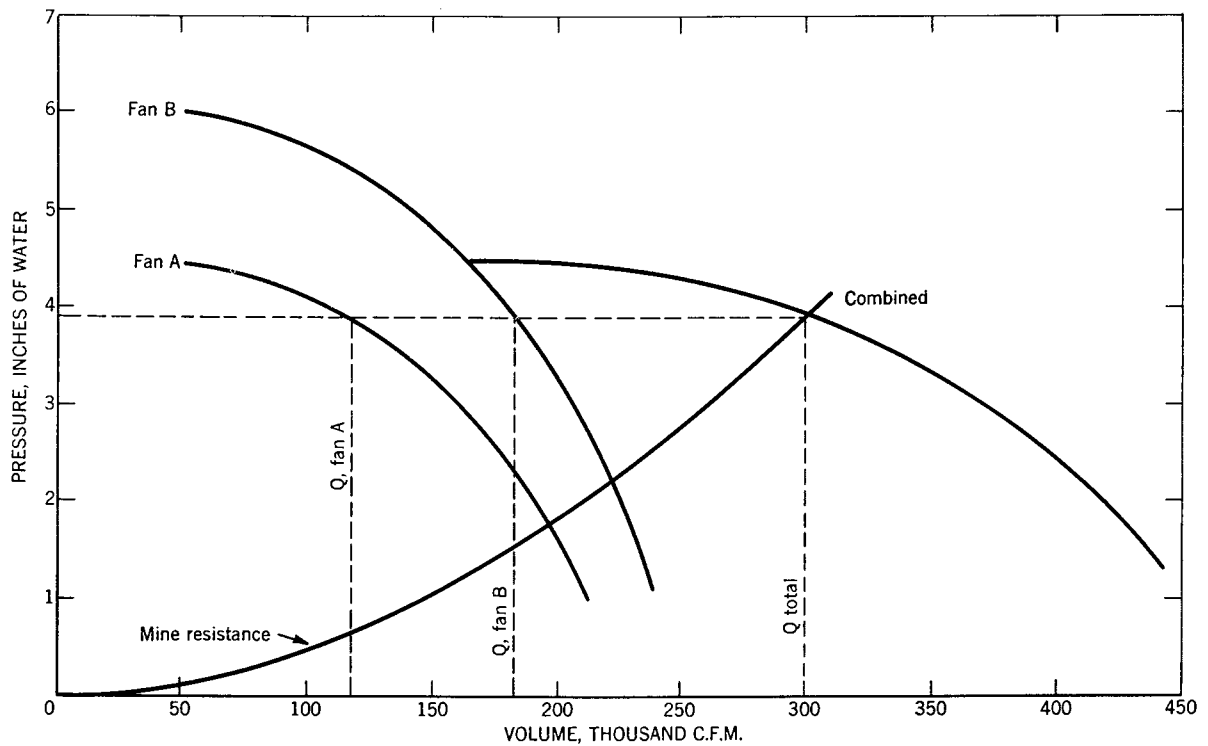

FIGURE 21.—Two Different Fans Operating in Parallel.

make up the total air quantity of 300,000 c.f.m.

Figure 22 shows parallel fans operating on separate airways. This problem is more complicated than the previous performance curves for parallel operation.

This problem involves placing a new fan in service and splitting the duty previously handled alone by fan B. Fan A is installed with a separate return segment connected to the mine ventilating system at junction X.

The natural splitting and pressures at which the fans will operate can be determined graphically if the resistance factors for separate segments of the system are known or can be calculated.

The procedure follows:

1. Plot both fan characteristic curves on one graph.

2. Plot resistance curves for each segment from formula $H=RQ^2$.

3. Determine the amount of air desired, for example, 200,000 c.f.m., and determine whether this quantity of air will flow under prevailing conditions.

A. Since segment *c* will handle all air going to segments *a* and *b*, from the plotted resistance curve *c* determine the pressures necessary to move 200,000 c.f.m. This is 4 inches water pressure. Should the original air quantity desired have been 250,000 c.f.m., this quantity strikes the resistance curve of segment *c* at approximately 6.7 inches water. Obviously, this is beyond the limit of fan A at the characteristic curve shown. Should the original air quantity desired have been 150,000

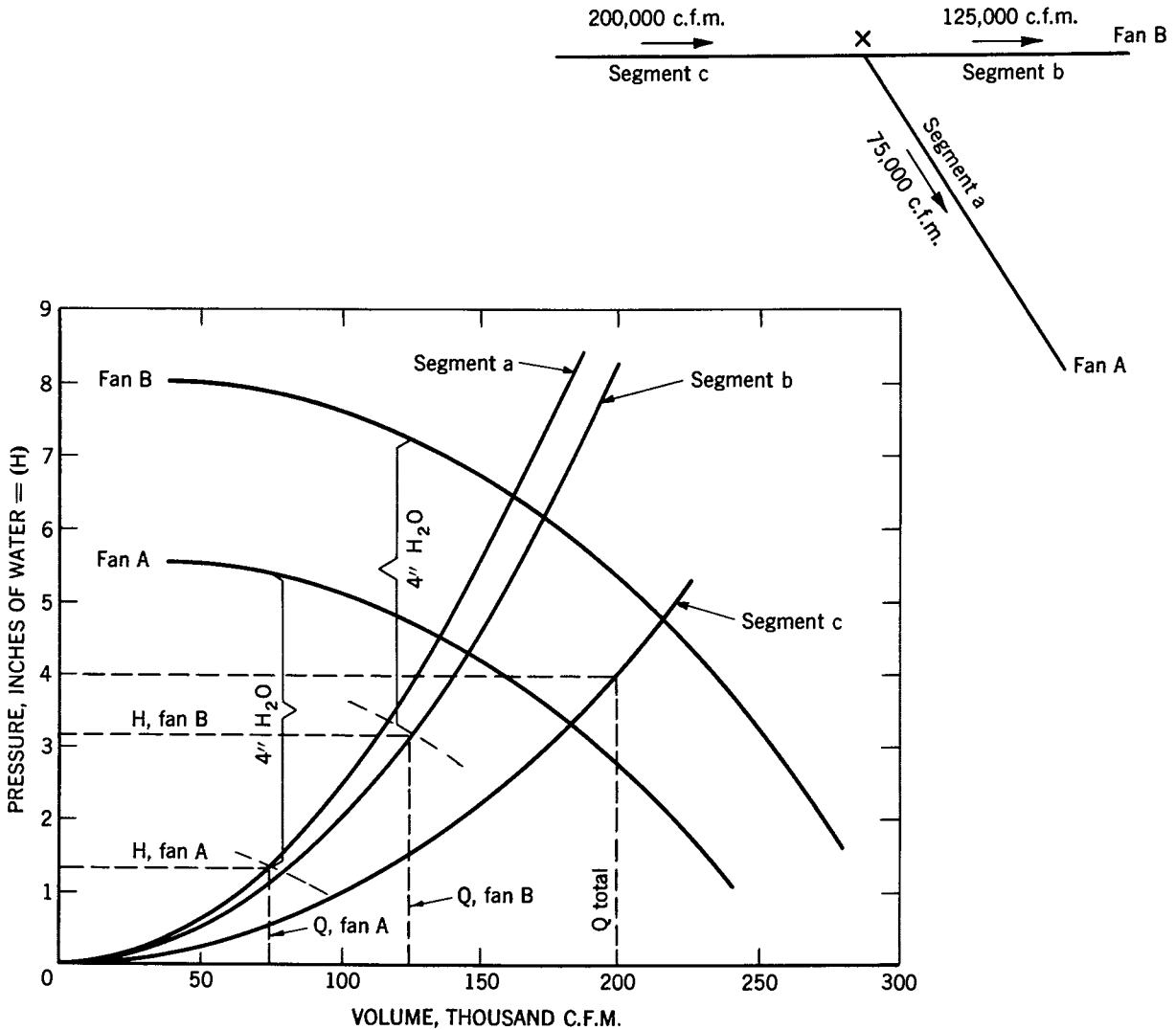

FIGURE 22.—Parallel Fans Operating on Separate Airways.

c.f.m., the following situation holds: 150,000 c.f.m. strikes the resistance-curve segment *c* at 2.25 inches water pressure—obviously not good for the operation of fan B.

4. To determine the pressure necessary to overcome the resistance of segments *a* and *b* and the air-quantity distribution, 4 inches water pressure must be subtracted from the characteristic curves *A* and *B*. Where these points intersect the segment resistance curves *a* and *b*, air quantities and pressures are indicated.

5. If the sum of the air quantities indicated by segment intersections *a* and *b* do not total the quantity tested in segment *c*, another trial must be made until the quantities are correct. In the example we started with a quantity of 200,000 c.f.m., moving up to intersect the resistance curve *c*. This requires a pressure of 4 inches water, which must be provided by the combined fans, but it applies only to segment *c*. Therefore, we subtract 4 inches of water from the characteristic curves of fans *A* and *B* and see where this intersects segment curves *a* and *b*. In the illustration they intersected at $q=75,000$ c.f.m., $H=1.4$ inches water for fan *A*; and at $q=125,000$ c.f.m., $H=3.15$ inches water for fan *B*. The sum of these quantities equals 200,000 c.f.m., which satisfied segment *c*. The fan pressures would then be:

$$A=4.00+1.40=5.40 \text{ inches water.}$$

$$B=4.00+3.15=7.15 \text{ inches water.}$$

This type of graphic solution quickly determines whether two or more fans will work in parallel and what performance can be expected.

NATURAL-VENTILATION INFLUENCE OF AIR DENSITIES

Natural ventilating pressures are induced by differences of total weights of air columns for the same vertical distance. Natural draft may operate with or against the mechanical draft (fig. 24) or may be the only source of pressure.

Natural draft pressures at near standard density can be estimated quickly as 0.030-inch water gage for each 10° F. average temperature difference per 100-foot increment of vertical elevation. For accurate determinations the average air densities of influencing air columns must be calculated.

Temperature conditions are so variable in mines that rigid mathematical solutions for

FANS IN COMBINATION

Most multiple-fan ventilating systems in coal mines use two or more fans in combination rather than in series or parallel operation. By combined operation, each fan, although it may share an airway with another fan, has an individual zone of influence with intakes and returns. Figure 23 illustrates the combined operation of a mine segment with two fans. Both fans induced some air through the slope. However, with fan *A*, the slope was the principal intake. The principal intake for fan *B* was, of course, the shaft. Both fans had individual return systems and general zones of influence. Figure 23 also shows the pressure gradient for this section of the mine. As can be seen, intake air traveled to the main junction *C* from both the slope and intake shaft. The pressure loss along the intake amounted to 0.7 inch water. The intake air was split at *C*—one split North and one split South. Part of the air was returned through back entries to points (*b-b*), at a pressure loss of 0.3 inch water. From points (*b-b*), air traveled to both fan *B* and fan *A*; the air returned to fan *A* began with small air quantities, which were increased by leakage and by air coming from bleeder entries of both the North and South sections. An indication of the pressure drops for both main splits are shown. To return, junction-*X* air will flow from points *b-b* and the bleeders. From point *X* to fan *A*, air may travel the returns or again enter the North bleeder system. Two paths are indicated to illustrate that, although air-flow does not follow similar airways, each split does not have the same volume of airflow, and secondary splits through the gob and bleeders will differ; pressure drops between points, such as from point *b* to fan *A*, will be identical in all splits.

average temperatures and absolute pressures are impracticable. For practical purposes it is accurate enough to determine the average densities for each column from averages of temperatures and barometric pressures.

Figure 25 shows the conditions of natural draft. This example is calculated as follows:

SHAFT A

Average temperatures:

$$\text{Wet bulb}=45^{\circ} \text{ F.}+53^{\circ} \text{ F.} \div 2=49.0^{\circ} \text{ F.,}$$

$$\text{Dry bulb}=50^{\circ} \text{ F.}+59^{\circ} \text{ F.} \div 2=54.5^{\circ} \text{ F.}$$

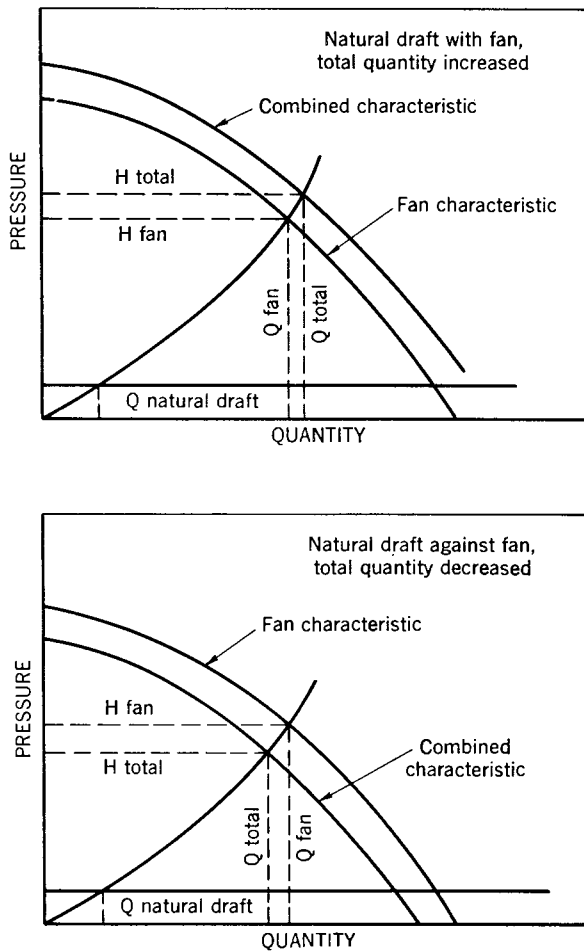

FIGURE 24.—Influence of Natural Draft to Mechanical-Ventilation Performance.

Average barometric pressure = 28.95 inches hg,
+ 29.80 inches hg $\div 2 = 29.38$ inches hg.

Dry-bulb temperature minus wet-bulb temperature equals wet-bulb depression.

54.5° F. - 49.0° F. = 5.5° F. wet-bulb depression.

From psychrometric tables (table 3), as previously explained for air densities: At air temperature 54.5° F. and 5.5° depression, the temperature at the dewpoint is 43.7° F. The vapor pressure (V_p) at 43.7° F. is 0.284.

Average density

$$\begin{aligned} &= \frac{1.327}{460 + T} [B - (0.378 \times VP)], \\ &= \frac{1.327}{514.5} [29.38 - (0.378 \times 0.284)], \\ &= 0.00258 \times 29.27, \\ &= 0.0755 \text{ p.c.f.} \end{aligned}$$

SHAFT B

Average temperature:

Wet bulb, 65° F. + 63° F. $\div 2 = 64^\circ$ F.

Dry bulb, 65° F. + 63° F. $\div 2 = 64^\circ$ F.

Average barometric pressure = 28.75 inches hg
+ 29.60 inches hg $\div 2 = 29.18$ inches hg.

With saturated air, the temperature at the dewpoints is the temperature of the air—in this instance, 64° F.; the vapor pressure at 64° F. is 0.595.

Average density

$$\begin{aligned} &= \frac{1.327}{524} \times [29.18 - (0.378 \times 0.595)], \\ &= 0.00253 \times 28.96 \text{ inches hg,} \\ &= 0.0733 \text{ p.c.f.} \end{aligned}$$

SURFACE DENSITY

The surface density must be determined because shaft B is 200 feet higher than shaft A, and this air column also acts on the system.

Temperature at surface: 45° F. wet bulb,
50° F. dry bulb.

Wet-bulb depression, 5°.

Temperature at dewpoint, 40° F.

Vapor pressure at dewpoint, 0.247.

Average barometer = 28.75 inches + 28.95 inches
 $\div 2 = 28.85$ inches hg.

Average density

$$\begin{aligned} &= \frac{1.327}{510} = [28.85 - (0.378 \times 0.247)], \\ &= 0.0026 \times 28.76, \\ &= 0.0748. \end{aligned}$$

MINE DENSITY

Average temperature:

Wet bulb = 53° F. + 65 $\div 2 = 59^\circ$,

Dry bulb = 59° F. + 65 $\div 2 = 62^\circ$.

Average barometer = 29.80 inches + 29.60
inches $\div 2 = 29.70$ inches hg.

Wet-bulb depression, 3° F.

Temperature at dewpoint, 57° F.

Vapor pressure at dewpoint, 0.465.

Average barometer = 29.70 inches hg.

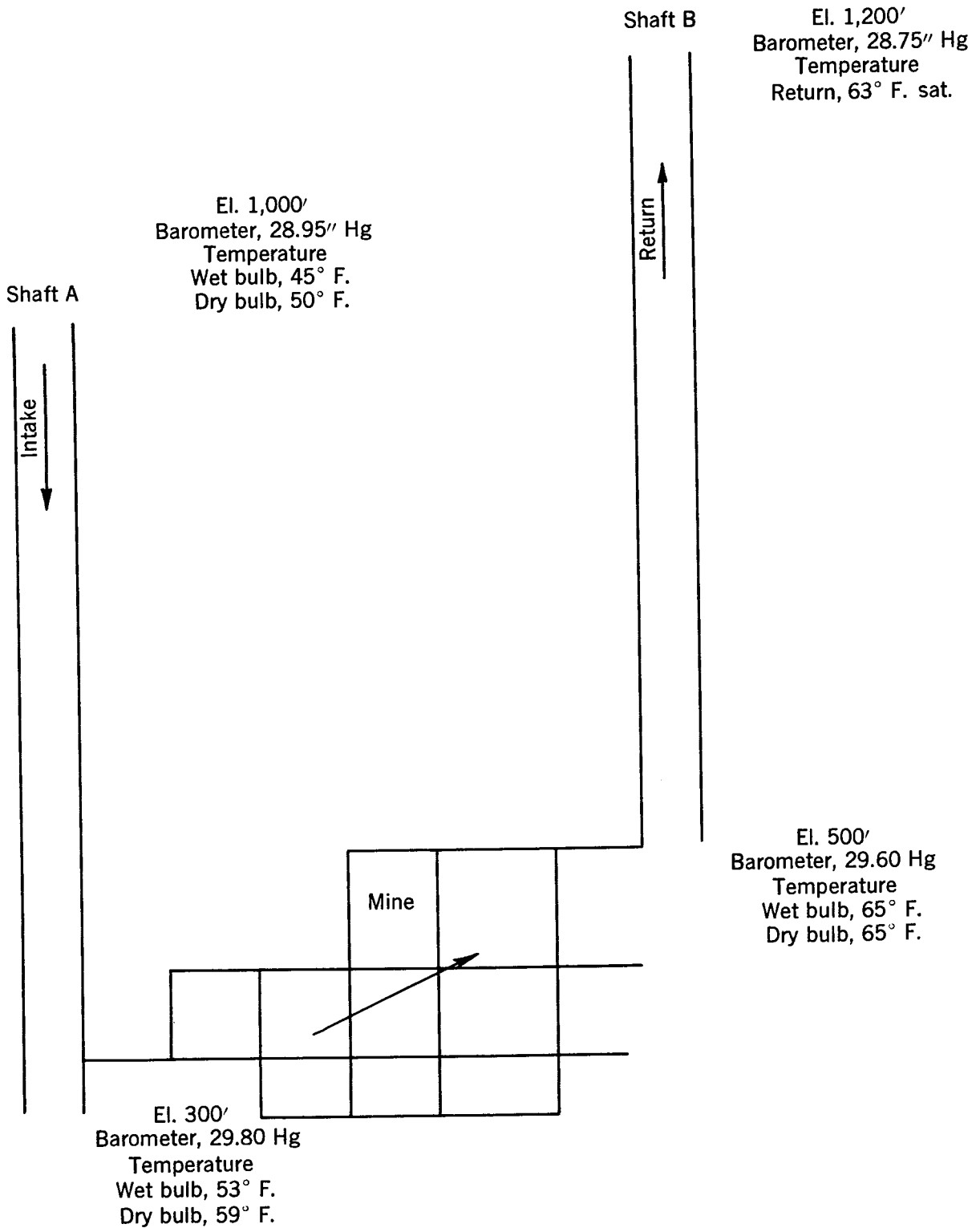

FIGURE 25.—Example of Conditions Causing Natural Draft.

Average density

$$\begin{aligned}
 &= \frac{1.327}{522} \times [29.70 - (0.378 \times 0.465)], \\
 &= 0.00254 \times 29.52, \\
 &= 0.0750 \text{ p.c.f.}
 \end{aligned}$$

WEIGHTED AVERAGE OF DENSITIES**SHAFT A**

$$\left. \begin{aligned}
 200 \text{ feet of surface density} \\
 \quad = 200 \times 0.0748 = 14.96 \\
 700 \text{ feet of shaft density} \\
 \quad = 700 \times 0.0755 = 52.85
 \end{aligned} \right\} 67.81.$$

$$\text{Average density} = \frac{67.81}{900} = 0.0753 \text{ p.c.f.,} \\
 \text{column A.}$$

SHAFT B

$$\left. \begin{aligned}
 700 \text{ feet of shaft density} \\
 \quad = 700 \times 0.0733 = 51.31 \\
 200 \text{ feet of mine density} \\
 \quad = 200 \times 0.0750 = 15.00
 \end{aligned} \right\} 66.31.$$

$$\text{Average density} = \frac{66.31}{900} = 0.0737 \text{ p.c.f.,} \\
 \text{column B.}$$

The difference between the average densities of both columns:

$$\begin{array}{r}
 \text{Column A} \dots\dots \text{p.c.f. } 0.0753 \\
 \text{Column B} \dots\dots \text{p.c.f. } 0.0737 \\
 \hline
 \text{Difference} \dots\dots \text{p.c.f. } 0.0016
 \end{array}$$

The height of the air column was 900 feet.

$$900 \times 0.0016 = 1.44 \text{ pounds pressure;}$$

$$1.44 \div 5.2 = 0.28 \text{ inch water pressure.}$$

The natural draft under conditions shown would work with an exhaust fan. Under other conditions of temperature this pressure could work against the fan.

The amount of air that would flow from this natural draft would depend on resistances of the mine and shafts. Assuming that the mine resistance was 2, the flow would be calculated by $H = RQ^2$, $Q^2 = \frac{H}{R}$,

$$Q^2 = \frac{0.28}{2} = 0.140,$$

$$\begin{aligned}
 q &= \sqrt{0.140} \times 100,000, \\
 &= 37,500 \text{ c.f.m.}
 \end{aligned}$$

Calculating the densities without considering the effect of vapor pressures, the results are as follows:

Shaft A: Average temperature, 54.5° F. dry bulb;
Average barometer, 29.38 inches hg;
Density = $\frac{1.327}{514.5} \times 29.38 = 0.0758$
p.c.f.

Shaft B: Average temperature, 64° F. dry bulb;
Average barometer, 29.18 inches hg;
Density = $\frac{1.327}{524} \times 29.18 = 0.0739$
p.c.f.

Surface: Temperature, 50° F. dry bulb;
Average barometer, 28.85 inches hg;
Density = $\frac{1.327}{510} \times 28.85 = 0.0751$ p.c.f.

Mine: Average temperature, 62° F. dry bulb;
Average barometer, 29.70 inches hg;
Density = $\frac{1.327}{522} \times 29.70 = 0.0755$ p.c.f.

The weighted average is:

$$\left. \begin{aligned}
 \text{Column A} &= 200 \times 0.0751 = 15.02 \text{ surface} \\
 700 \times 0.0758 &= 53.06 \text{ shaft A}
 \end{aligned} \right\} 68.08. \\
 68.08 \div 900 = 0.0756 \text{ p.c.f. average density.}$$

$$\left. \begin{aligned}
 \text{Column B} &= 200 \times 0.0755 = 15.10 \text{ mine} \\
 700 \times 0.0739 &= 51.73 \text{ shaft B}
 \end{aligned} \right\} 66.83. \\
 66.83 \div 900 = 0.0742 \text{ p.c.f. average density.}$$

$$\begin{array}{r}
 \text{Column A} \dots\dots \text{p.c.f. } 0.0756 \\
 \text{Column B} \dots\dots \text{p.c.f. } 0.0742 \\
 \hline
 \text{Difference} \dots\dots \text{p.c.f. } 0.0014
 \end{array}$$

$$\begin{aligned}
 0.0014 \times 900 &= 1.26 \text{ pounds pressure;} \\
 1.26 \div 5.2 &= 0.24 \text{ inch water pressure.}
 \end{aligned}$$

Considering all variables, this result is probably as accurate as the computed 0.28 inch water pressure of the first calculation. Both methods were given for illustration and comparison. For mines deeper than 1,500 feet, the influence of vapor pressures is important and must be considered.

PART II

APPLICATION OF AIRFLOW FUNDAMENTALS

The second part of this bulletin is devoted to the practical application of airflow fundamentals. Several problems are discussed; a general knowledge of ventilation requirements and methods used in mines and an understanding of simple algebra are presupposed. The derivation of certain basic ventilating formulas is given.

DERIVATION OF VENTILATING FORMULAS

1. Formula for conversion of velocities and velocity pressures:

$$V = 4,000 \sqrt{VP}$$

where

VP equals the velocity pressure in inches water.

This formula is derived from the basic formula

$$V^2 = 2gh \quad \text{where } V = \text{velocity f.p.s.,}$$

$$V = \sqrt{2gh} \quad g = \text{gravity of 32.2 f.p.s.,}$$

$$h = \text{height in feet.}$$

Changing the velocity from feet per second to feet per minute, the formula becomes:

$$V = 60 \times \sqrt{2gh}$$

Extracting the square root of $2g$, or 2×32.2 , and removing from under radical

$$V = 8.02 \times 60 \sqrt{h}$$

$$= 481.2 \sqrt{h}$$

The height of air column h can be converted to equivalent inches of water at standard air density as follows:

1 foot of air column at 0.075 p.c.f. = 0.075
 \div by 5.2, or 0.0144 inch water pressure;

1 inch of water pressure H then equals 1
 \div by 0.0144, or 69.5 feet of air column.

The formula then becomes:

$$V = 481.2 \sqrt{69.5 \times VP}$$

where VP is expressed in inches water pressure:

$$V = 481.2 \times 8.34 \sqrt{VP}$$

$$V = 4,000 \sqrt{VP} \text{ for practical application.}$$

2. Formula for computing the areas or pressure losses through regulators:

$$A = \frac{40 \times Q}{\sqrt{H}}$$

A = area regulator, square feet,
 Q = quantity c.f.m. in units of 100,000,
 H = pressure loss through regulator inches water.

This formula is also derived from $V^2 = 2gh$:

$$V^2 = 2gh,$$

$$V = \sqrt{2gh} \text{ velocity f.p.s.,}$$

$V = 60 \times \sqrt{2gh}$ velocity f.p.m. (From fundamental laws the air quantity q equals the velocity V times the area in square feet.)

$$q = VA.$$

$$V = 4,000 \sqrt{H} \text{ (from the previous formula);}$$

therefore

$$q \text{ equals } 4,000 \sqrt{H} \times A.$$

With box-type regulators and sharp-edged orifices a correction must be made for the *Vena Contracta*, which in effect reduces the area of the orifice. The *Vena Contracta* is a condition that occurs whenever there is a substantial increase in air velocity caused by abrupt area restrictions, such as caused by regulators. The accelerated air momentum does not completely fill the area of the restriction. The percentage of area filled will be influenced by several factors, the most important being the airspeed through the regulator and the ratio of the regulator area to entry area. The correction for *Vena Contracta* usually is 65 percent of the regulator area.

$$q = 4,000 A \sqrt{H} \times 0.65,$$

$$q = 2,600 A \sqrt{H},$$

$$A = \frac{q}{2,600 \sqrt{H}} = \frac{1}{2,600} \times \frac{q}{\sqrt{H}}$$

$$= 0.00039 \times \frac{q}{\sqrt{H}} = \frac{0.0004q}{\sqrt{H}}$$

To simplify further, use Q in units of 100,000 c.f.m. The formula then becomes:

$$\text{Area} = \frac{40Q}{\sqrt{H}}$$

3. Common ventilation formula $H = \frac{KLOq^2}{5.2A^3}$:

This formula is based upon the hydraulic law for turbulent flow of a fluid through a straight duct of uniform cross section, assuming that the pressure loss varies as the square of the velocity and is generally applicable either to liquids or to gases.

$h = \frac{fLV^2}{2gr}$ is the hydraulic law for turbulent flow,

h = pressure loss of flow, expressed in head of feet of fluid flowing,

f = friction factor, based upon rubbing surfaces,

L = length, in feet,

V = average velocity, feet per second,

g = acceleration due to gravity 32.2 f.p.s.,

r = hydraulic radius (equals the area of the duct divided by the perimeter of air or liquids filling duct).

$\frac{A}{O}$ = where A = area, and O = the airway perimeter.

The formula then becomes:

$$h = \frac{fLV^2}{2g} \times \frac{O}{A}$$

The common ventilation formula

$$\left(P = \frac{KLOV^2}{A} \right)$$

is derived as follows:

P (the pressure, pounds per square feet) equals the head of the air column times the air density (d), expressed in pounds per cubic foot.

$$P = h \times d, \quad h = \frac{P}{d};$$

therefore

$$\frac{P}{d} = \frac{fV^2}{2g} \times \frac{LO}{A} \text{ with velocity in feet per second,}$$

$$\frac{P}{d} = \frac{fV^2}{2g \times (60)^2} = \frac{LO}{A} \text{ with velocity in feet per minute,}$$

$$P = \frac{df}{2g \times 3,600} \times \frac{V^2 LO}{A}$$

$\frac{df}{2g \times 3,600}$ forms K , the ventilating friction factor.

Substituting K ,

then

$$P = K \times \frac{LOV^2}{A}$$

$$q = VA,$$

$$V = \frac{q}{A},$$

$$V^2 = \left(\frac{q}{A} \right)^2,$$

then

$$P = K \times \frac{LOq^2}{A^3}$$

H , pressure in inches water, equals P , pressure in pounds per square foot, divided by 5.2:

$$H = \frac{P}{5.2},$$

$$P = H \times 5.2,$$

then

$$5.2H = \frac{KLOq^2}{A^3},$$

$$H = \frac{KLOq^2}{5.2A^3}$$

4. Formula for total resistance of series and parallel flow:

Series, flow, and the combined resistance for any individual air split are found simply by adding the individual resistance factors of the increments making up the air split.

$$R \text{ total} = R_1 + R_2 + R_3 + \dots + R_n.$$

For parallel flow through two or more airways with individual resistances of $R_1, R_2, R_3, + R_n$, the equivalent resistance R representing all airways involves the square relationship previously discussed. The formula for total resistance of parallel flow equals $\frac{1}{\sqrt{R}} = \frac{1}{\sqrt{R_1}} + \frac{1}{\sqrt{R_2}} + \frac{1}{\sqrt{R_3}} + \frac{1}{\sqrt{R_n}}$ and is derived as follows:

$$H = RQ^2, \quad Q^2 = \frac{H}{R}, \quad Q = \sqrt{\frac{H}{R}}$$

$$\text{Total } Q = Q_1 + Q_2 + Q_3 + Q_n$$

$$= \sqrt{\frac{H}{R_1}} + \sqrt{\frac{H}{R_2}} + \sqrt{\frac{H}{R_3}} + \sqrt{\frac{H}{R_n}}$$

$$\text{Total } Q \text{ also equals } \sqrt{\frac{H}{\text{Total } R}};$$

therefore

$$\sqrt{\frac{H}{\text{Total } R}} = \sqrt{\frac{H}{R_1}} + \sqrt{\frac{H}{R_2}} + \sqrt{\frac{H}{R_3}} + \sqrt{\frac{H}{R_n}}$$

All pressure losses H in a parallel circuit are

the same, so the symbol \sqrt{H} can be removed ;

therefore

$$\frac{1}{\sqrt{R}} = \frac{1}{\sqrt{R_1}} + \frac{1}{\sqrt{R_2}} + \frac{1}{\sqrt{R_3}} + \frac{1}{\sqrt{R_n}}$$

SOLUTION OF PROBLEM EXAMPLES

The following problems are typical of those often encountered in mines. Without the application of ventilating principles, the solution often is left to trial-and-error methods. We do not maintain that solutions derived by calculation give the absolute answer; conditions in a mine are not static, and neither are mining methods. Calculated solutions, however, point out with a relatively good degree of accuracy what must be done to achieve certain desired results and what can be expected of the present ventilating system under various conditions.

PROBLEM 1: PRESSURE VOLUME COMPUTATIONS FOR A NEW MINE

A new coal mine is projected, with entrance by slope 1,500 feet long. Nine main entries will be standard for development, five as intake and four as return. One return shaft is planned near the slope bottom, and an intake shaft and portal are planned 5,000 feet north of the slope bottom. The slope will have an area of 150 square feet and a perimeter of 55 feet. A belt and supply track will be within the slope. The return shaft will be circular with a diameter of 18 feet and will be 500 feet deep with an escapeway. Two hundred feet of the shaft and 500 feet of the slope will be concrete lined.

Will it be possible to operate five units per shift and drive the 5,000 feet to a proposed new portal, using the slope for an intake? Two main splits are planned with the maximum of three units on any split. The amount of air desired at each unit is 25,000 c.f.m.; a shop at the slope bottom will require 10,000 c.f.m.

In the solution of this or any similar problem the first step is to determine the resistance factors.

CALCULATION OF R FACTORS

Slope area=150 sq. ft. Perimeter=55 feet.
Length=1,500 feet.

The friction factor K must be established:

Five hundred feet of the slope is smooth lined, moderately obstructed by belt; $K=35$ (ref., table 4).

The remaining 1,000 feet is in sedimentary rock moderately obstructed by belt; $K=85$ (ref., table 4).

SLOPE

$$\left. \begin{aligned} \text{Weighted average} &= 500 \times 35 = 17,500 \\ &= 1,000 \times 85 = 85,000 \end{aligned} \right\} 102,500.$$

$$102,500 \div 1,500 = 68;$$

therefore

$$K = 68 \text{ average,}$$

$$R = \frac{KLO}{5.2A^3} = \frac{68 \times 1,500 \times 55}{5.2 \times 150 \times 150 \times 150} = 0.32.$$

SHAFT

Diameter=18 feet. $A = \pi \times (9)^2 = 254$ sq. ft.

Perimeter= $\pi D = \pi \times 18 = 56.5$ ft.

Determine K factor:

200 feet of concrete-lined shaft, obstructed by escapeway; use maximum $K=35$ (ref., table 4);

300 feet of sedimentary rock, also obstructed by escapeway; $K=85$ (ref., table 4).

$$\left. \begin{aligned} \text{Weighted average} &= 200 \times 35 = 7,000 \\ &= 300 \times 85 = 25,500 \end{aligned} \right\} 32,500.$$

$$32,500 \div 500 = 65;$$

therefore

$$K = 65 \text{ average,}$$

$$R = \frac{KLO}{5.2A^3} = \frac{65 \times 500 \times 57}{5.2 \times 254 \times 254 \times 254} = 0.02.$$

ENTRIES

With entries, R factors are calculated on a basis of unit length per 1,000 feet; these entries will average 6 by 12 feet.

Area=72 sq. ft. Perimeter=36 ft.

The friction factor will be 80 for intakes and 100 for returns, since intakes will be better maintained than returns. Moreover, this is a new development. For old entries, the K factors should be substantially greater. These friction factors were based upon open field experience.

Intakes:

$$1 \text{ entry } R = \frac{KLO}{5.2A^3} = \frac{80 \times 1,000 \times 36}{5.2 \times 72 \times 72 \times 72} = 1.48 \text{ (use 1.5).}$$

$$5 \text{ entries } R = \frac{R_1}{(5)^2} = \frac{1.5}{25} = 0.06.$$

Returns:

$$1 \text{ entry } R = \frac{100 \times 1,000 \times 36}{5.2 \times 72 \times 72 \times 72} = 1.85 \text{ (use 1.9).}$$

$$4 \text{ entries } = \frac{1.9}{(4)^2} = \frac{1.9}{16} = 0.12.$$

Leakage factors must be considered. With new development and two rows of stoppings between intakes and returns, a leakage factor of 80 percent of the air reaching the face is fair; this, of course, could be substantially more or less.

The total air quantity required for five operating units will be:

	C.f.m.
5 units at 25,000 c.f.m. per unit.....	125,000
Ventilation, idle developed Butts.....	20,000
Leakage, 80 percent \times 145,000.....	116,000
Ventilation for shops.....	10,000
Total.....	271,000

¹ Round off to 270,000 c.f.m.

The simplest way to calculate an air-current circuit is to use a standard computation sheet.

EXPLANATION OF COMPUTATION SHEET

Segment: Represents portion or increment of ventilation split studied; established at points of splitting or airway changes.

Distance: Distance of segment, in feet.

Number of entries: Number of entries in segment.

Area: Average area of individual entries listed for reference.

R 1,000 feet: Resistance factor established for segment per 1,000 feet.

R total: Total R factor; equals distance divided by 1,000 times R factor per 1,000 feet.

Q₁: Air quantity at beginning of segment, divided by 100,000.

Q₂: Air quantity at end of segment, divided by 100,000.

Gains or losses: Gains or losses from leakage or other causes.

Average Q: Average air quantity flowing in segment, in units of 100,000 c.f.m.

H segment: Pressure drop calculated for segment $H = \text{total } R \times \text{average } Q^2$.

Total H: Sum of segments H to aggregate pressure drop.

Figure 26 shows the air quantities and is used to explain the computations. The South Main split was divided into segments A, B,

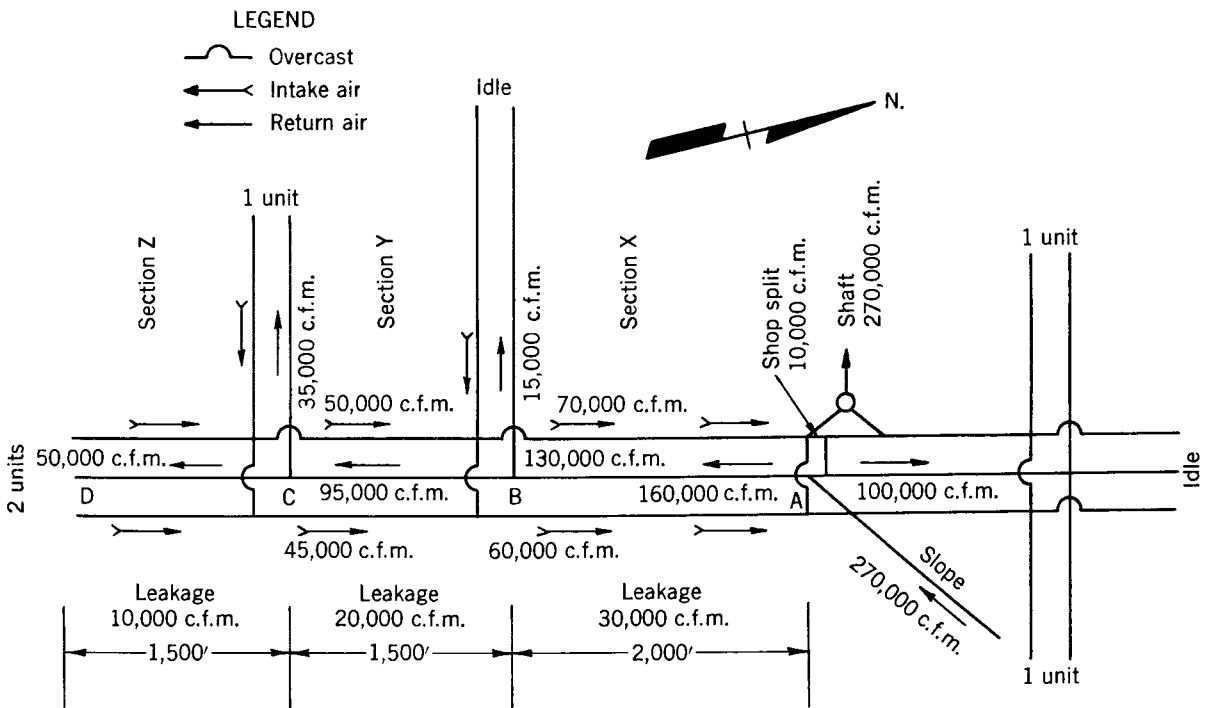

FIGURE 26.—Mine and Ventilation Plan. Problem 1.

C, and D, as shown. Other segments are the shaft and the slope. Computing intakes, we begin at the slope—the first segment. This is simple because there is no leakage. The *R* factor has been established, so that pressure is the intake quantity squared times the *R* factor.

Segment A-B begins the Main South split. Three units to operate. The number of entries and the unit *R* factor have been established. The distance is 2,000 feet, so the total *R* is twice the unit *R* per 1,000 feet. The air quantity at the beginning is the total incoming air (270,000 c.f.m.) less the following deductions for the North split:

	<i>C.f.m.</i>
2 units at 25,000 c.f.m. per unit	50,000
Leakage, 80 percent	40,000
Shop split	10,000
Idle section	10,000
Total	110,000

Therefore,

$q_1 = 270,000 - 110,000 = 160,000$ c.f.m., and $q_2 = q_1$ less assigned leakage along mains, unless actual losses are known. Leakages are assigned on a distance basis, so losses of 30,000 c.f.m. were assigned; therefore,

$$q_2 = 160,000 - 30,000 = 130,000 \text{ c.f.m.}$$

The average quantity is, of course, the average of 160,000 c.f.m. and 130,000 c.f.m., or 145,000 c.f.m. The average air quantity is then squared, and the pressure loss through segment A-B is calculated from the resistance factor.

The return air is calculated on the same basis, except with returns the air volume is increasing as the various losses and split returns build up.

Secondary splits to operating sections X and Y were not calculated, since the drop through section Z at 50,000 c.f.m. was obviously greater than the drop through these sections.

Computation sheet

$$H = RQ^2 \quad Q = \frac{\text{Actual quantity}}{100,000}$$

Mine segment	Distance, feet	Number of entries	Area	<i>R</i> , 1,000 feet	<i>R</i> , total	<i>Q</i> ₁ , beginning	<i>Q</i> ₂ , end	Gain or losses	Average <i>Q</i>	<i>Q</i> ²	Segment <i>H</i>	Total <i>H</i>
INTAKE												
Slope	1,500	1	150	0.32	0.32	2.70	2.70		2.70	7.3	2.34	
A-B	2,000	5	72	0.06	.12	1.60	1.30	0.30	1.45	2.1	.25	2.59
B-C	1,500	5	72	.06	.09	1.15	.95	.20	1.05	1.1	.10	2.69
C-D	1,500	5	72	.06	.09	.60	.90	.10	.55	.3	.03	2.72
Drop across faces25	¹ 2.97
RETURN												
D-C	1,500	4	72	0.12	0.18	0.50	0.60	+ .10	0.55	0.3	0.05	
C-B	1,500	4	72	.12	.18	.95	1.15	+ .20	1.05	1.1	.20	0.25
B-A	2,000	4	72	.12	.24	1.30	1.60	+ .30	1.45	2.1	.50	.75
Shaft	500	1	256		.02	2.70	2.70		2.70	7.3	.15	² 2.90
												³ 3.87

¹ Intake. ² Return. ³ Split.

Conclusions: These computations show that approximately 4.0 inches water pressure will be necessary. Over half of the system energy loss is in the slope, which will have a velocity of approximately 1,800 f.p.m. blowing dust into the mine. The North split of two units must have the same pressure drop, obtained by regulation.

PROBLEM 2: FAN PRESSURE NECESSARY TO INCREASE AIR QUANTITY IN AN OLD MINE

A belt mine proposes to increase ventilation at each operating unit to 25,000 c.f.m. The

mine is operating with two main air splits, each servicing four producing units. The mine is laid out with a panel system, which operates two units per panel (ref., fig. 27). Idle sections will be ventilated from the belt entries, which will be considered neutral but will carry 10,000 c.f.m. for main and 5,000 c.f.m. for panel belts. Main entries will total 10—4 for intake, 5 for return, and a belt entry; panel entries will total 5—2 intake, 2 return, and 1 belt entry. The average entry dimensions are 6 by 12 feet. Outby point X, return entries are caved but open; resistance to airflow is much greater than for average entries.

The amount of air required and the air distribution are as follows:

	<i>C.f.m.</i>
Total air quantity: 8 units at 25,000 c.f.m. per unit.....	200, 000
Leakage, 100 percent.....	200, 000
Ventilation belts ¹	20, 000
Total	420, 000

¹ The air distribution would be: Intake shaft, 420,000 c.f.m.

Each split will have four units and a belt to be ventilated. The North split will have all production from panels, and the South split will operate two units as development. Because of the reduced number of intakes and returns in panels, and with all units operating in panels the North split will have the highest pressure losses and will be calculated:

	<i>C.f.m.</i>
Intake North split, point A:.....	210, 000
To belt.....	10, 000
To intakes.....	200, 000

The belt entry will be regulated to 10,000 c.f.m. and will be considered neutral and not involved in the intake calculations. This is not entirely true, but to include the belt entry would complicate the problem more than the resultant accuracy would merit.

Intakes:	
Segment A-B (2,000 ft., 4 entries):	<i>C.f.m.</i>
Beginning.....	200, 000
Leakage.....	50, 000
End.....	150, 000
Split intake to panel 3.....	70, 000
Segment B-C (500 ft.):	
Beginning.....	80, 000
Leakage.....	10, 000
End.....	70, 000
Ventilation to idle section by belt.....	10, 000
Segment C-D, intake to panel 4 (1,500 ft., 2 entries):	
Beginning.....	70, 000
Belt entry.....	5, 000
	65, 000

Intakes—Continued	
Segment C-D, intake to panel 4—Continued	
Leakage.....	15, 000
To producing units.....	50, 000
Returns:	
Segment D-C (face to junction with mains):	
Beginning.....	50, 000
Belt.....	5, 000
	55, 000
Leakage.....	15, 000
End.....	70, 000
Segment C-B (gain 10,000 from idle section):	
Beginning.....	80, 000
Leakage.....	10, 000
End.....	90, 000
Segment B-X (gain 70,000 from panel 3). X is point where resistance to airflow increases:	
Beginning.....	160, 000
Leakage.....	15, 000
End.....	175, 000
Segment X-A:	
Beginning.....	175, 000
Leakage.....	35, 000
End at return shaft.....	210, 000

CALCULATION OF R FACTORS

Resistance factors for shafts: Both shafts are 18 feet in diameter, 300 feet deep, concrete lined throughout, and moderately obstructed; $K=25$:

$$R = \frac{KLO}{5.2A^3} = \frac{25 \times 300 \times 57}{5.2 \times 254 \times 254 \times 254} = 0.005.$$

R factors for entries, 1,000 feet:

Intake entries single entry, $K=80$:

$$R = \frac{80 \times 1,000 \times 36}{5.2 \times 72 \times 72 \times 72} = 1.50.$$

Return entries, single entry, $K=100$:

$$R = \frac{100 \times 1,000 \times 36}{5.2 \times 72 \times 72 \times 72} = 1.85 \text{ (use 1.90).}$$

Return entries outby point X, $K=200$:

$$R = \frac{200 \times 1,000 \times 36}{5.2 \times 72 \times 72 \times 72} = 3.7.$$

$$\text{Intake 4 entries} = \frac{1.5}{16} = 0.09.$$

$$\text{Intake 2 entries} = \frac{1.5}{4} = 0.38.$$

$$\text{Return 2 entries} = \frac{1.9}{4} = 0.48.$$

$$\text{Return 5 entries} = \frac{1.9}{25} = 0.08.$$

$$\text{Return 5 entries outby point X} = \frac{3.7}{25} = 0.15.$$

Computation sheet

Mine segment	Distance feet	Number of entries	Area	R, 1,000 feet	R, total	Q ₂ , beginning	Q ₂ , end	Gains or losses	Average Q	Q ₂	Segment H	Total
INTAKE												
Intake shaft					0.005	4.2	4.2		4.2	17.6		0.09
A-B	2,000	4	72	0.09	.18	2.0	1.5	-0.5	1.75	3.06	0.55	.64
B-C	500	4	72	.09	.05	.80	.70	-.10	.75	.56	.03	.67
C-D	1,500	2	72	.38	.57	1.65	.50	-.15	.58	.34	.19	.86
Drop through sections, 0.25 inch water												1.11
RETURN												
D-C	1,500	2	72	0.48	0.72	20.55	0.70	+0.15	0.63	0.40	0.29	1.40
C-B	500	5	72	.08	.04	.80	.90	+0.10	.85	.72	.03	1.43
B-X	500	5	72	.08	.04	1.60	1.75	+0.15	1.68	2.82	.11	1.54
X-A	1,500	5	72	.15	.22	1.75	2.10	+0.35	1.93	3.72	.82	2.36
Return shaft					.005	4.2	4.2		4.2	17.6	.09	2.45

X=point where higher R factor is necessary for caved returns. Total H=2.45. This indicates a pressure of approximately 2.45 inches water necessary to operate 8 units and provide air for belt ventilation.

¹ 5,000 c.f.m. for belt entry not calculated in intake-entry pressure losses.

² 5,000 c.f.m. from belt entry to return entries flows in return entries; calculated in return pressure losses.

PROBLEM 3: PRACTICAL APPLICATION OF FAN LAWS AND AIR DENSITIES

This problem illustrates the application of fan laws, influence of air densities, and natural draft to fan performance.⁵ The problem is entirely hypothetical.

The following data are available on the performance of two different fans:

	Fan A	Fan B
Speed..... r.p.m.	700	800
Density of air..... p.c.f.	0.070	0.075
Pressure H, inches water at following air volumes, c.f.m.:		
150,000..... inches	4.90	6.55
160,000..... do	4.62	6.05
170,000..... do	4.16	5.45
180,000..... do	3.64	4.70
190,000..... do	3.04	3.85
200,000..... do	2.29	2.80

These two fans are to be installed in series at an air density of 0.070 p.c.f.; both fans will operate at speeds of 800 r.p.m.

Mine resistance has been established at 3 inches water pressure for 100,000 c.f.m. at a density of 0.075 p.c.f.

The natural ventilating pressure is 0.5 inch water assisting fans.

What volume will the fans deliver? At what pressure will each fan operate?

COMPUTATION

The first step is to correct the pressure-volume data for each fan to 800 r.p.m., and a density of 0.070 p.c.f.

Fan A:

Fan law No. 1, correction for speed:

Multiply given volumes by $\frac{800}{700}$.

Fan law No. 2, correction for pressure:

Multiply given pressure by $\left(\frac{800}{700}\right)^2$.

Fan B:

No correction necessary for speed.

Correction for pressure:

Multiply given pressure by $\left(\frac{0.070}{0.075}\right)$.

Fan A

[Air density, 0.070 p.c.f.]

R.p.m., 700		R.p.m., 800	
Volume, c.f.m.	Pressure, inches water	Volume, c.f.m.	Pressure, inches water
150,000	4.90	171,500	6.40
160,000	4.62	183,000	6.03
170,000	4.16	194,300	5.43
180,000	3.64	205,000	4.75
190,000	3.04	217,000	3.97
200,000	2.29	229,000	2.99

¹ Volume = $\left(\frac{8}{7}\right) \times V_1$.

² Pressure = $\left(\frac{8}{7}\right)^2 \times H_1$.

⁵ Problem similar to one in article by Beadle, D. G., and Quilliam, J. H.: Jour. Mine Vent. Soc. of South Africa, vol. 10, October 1957, p. 239.

Fan B

R.p.m., 800; volume, c.f.m.	Pressure, inches water at density	
	0.075	0.070
		$\left(\frac{0.70}{0.75}\right) \times H_1$
150,000.....	6.55	6.11
160,000.....	6.05	5.65
170,000.....	5.45	5.09
180,000.....	4.70	4.39
190,000.....	3.85	3.59
200,000.....	2.80	2.61

Combined curve data, fans A and B

R.p.m., 800; volume, c.f.m.	Density, 0.070 p.c.f.		
	H, fan A ¹	H, fan B	H, combined
150,000.....		6.11	
160,000.....	6.71	5.65	12.36
170,000.....	6.45	5.09	11.54
180,000.....	6.12	4.39	10.51
190,000.....	5.67	3.59	9.26
200,000.....	5.12		

¹ Pressure-volume data, fan A, taken from curve of fan A (fig. 28) plotted from calculated data.

The curves plotted can be used to obtain the data necessary to determine the combined pressure-volume relationship of the fans (ref., fig. 28.)

Plotting these data forms the combined pressure-volume curve of both fans.

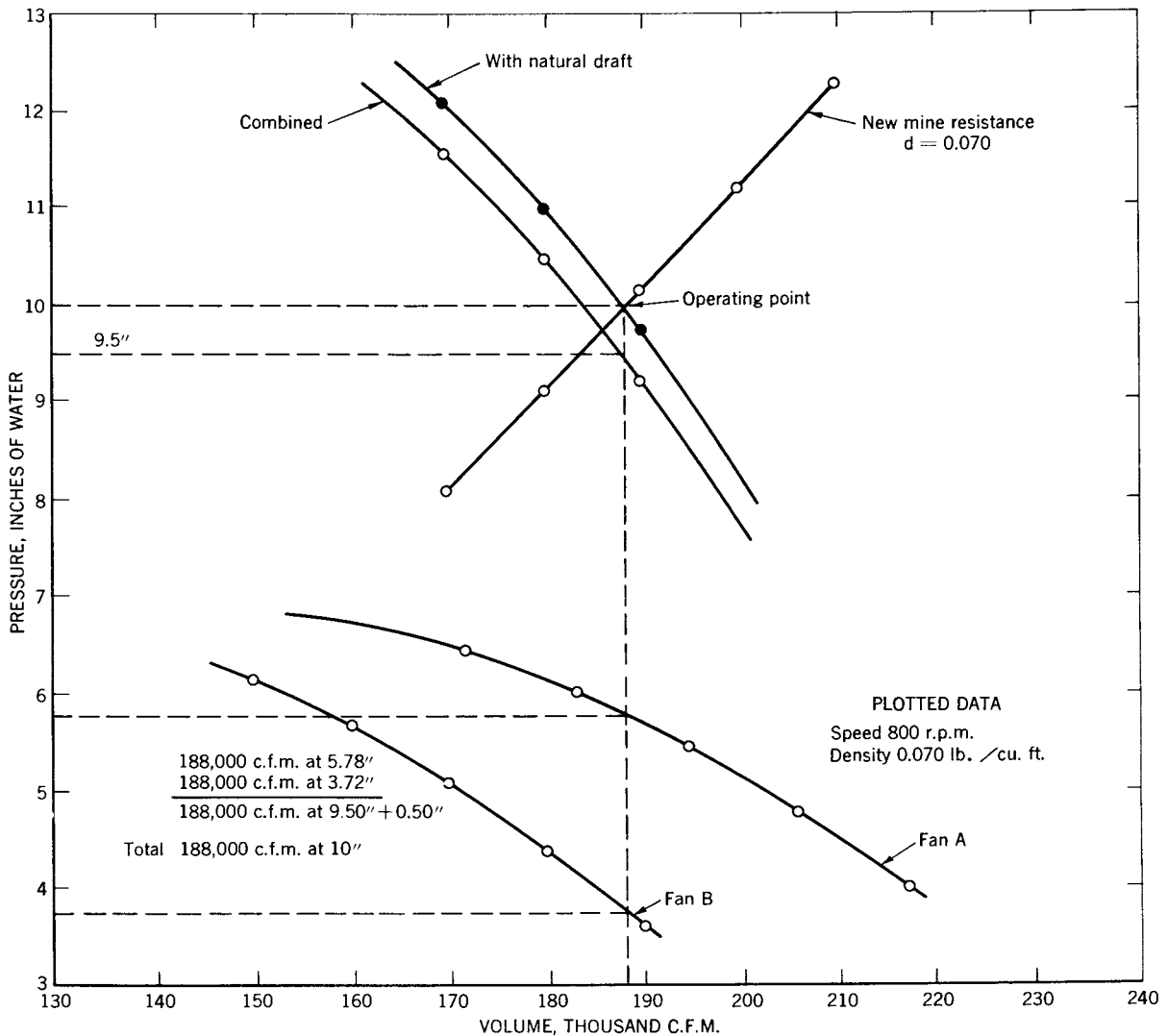

FIGURE 28.—Plotted Fan Data. Problem 3.

Influence of natural draft at 0.5 inch water

Volume, c.f.m.	H , combined	H , n.v.p.	H , total
160,000.....	12.36	0.50	12.86
170,000.....	11.54	.50	12.04
180,000.....	10.51	.50	11.01
190,000.....	9.26	.50	9.76
200,000.....			

Plotting these data forms the total pressure-volume relationship of all fans, plus natural draft (fig. 28).

The mine pressure H is 3 inches water at 100,000 c.f.m. at standard density. Therefore, the pressure at a density of 0.070 p.c.f. is

$$3 \times \frac{0.070}{0.075} = 2.8 \text{ inches water.}$$

Calculate the mine-resistance curves as follows, from the formula $H=RQ^2$, where $R=2.8$:

Air quantities, c.f.m.:	Pressure, inches water
170,000.....	8.1
180,000.....	9.1
190,000.....	10.1
200,000.....	11.2
210,000.....	12.3

Plot these data on figure 28. The operating point where the mine-resistance curve intersects the curve for combined fans and the natural draft indicates the air quantity expected at the fan pressure.

The total air quantity is 188,000 c.f.m. at a combined pressure of 10 inches water:
Total air quantity, 188,000 c.f.m.

Total air quantity, 188,000 c.f.m.:	Inches
Fan A.....	5.8
Fan B.....	3.7
Combined.....	9.5
Natural draft.....	.5
Total water pressure.....	10.0

PROBLEM 4: IMPROVED FACE VENTILATION BY MEANS OF NEW AIR SHAFT

Figures 29 and 30 show the line diagram and pressure gradient of a small slope mine as determined by a pressure survey. Overall air-leakage losses and resistance to airflow in the returns are excessively high. Of the 45,000 c.f.m. intake air, only 10,000 c.f.m. is available for face ventilation. Approximately 78 percent of the pressure losses was found to be in return aircourses and in the 6-foot-diameter unlined upcast shaft.

The fan (fig. 31) was operating at 5.5 inches water gage and a speed of 1,400 r.p.m., inducing an airflow of 45,000 c.f.m. The air horsepower was calculated to be 39. The input horsepower

was 63. Fan operating efficiency was 62 percent.

Assume that a new unlined airshaft, 10 feet in diameter, will be sunk 500 feet through sedimentary rocks to the coalbed at pressure-gradient point 9. What fan pressure will be necessary to provide 20,000 c.f.m. intake air to the face areas to ventilate two active longwall faces? What fan speed will deliver this quantity under improved conditions?

Because present returns are connected to old workings, most of the present return aircourses cannot be used as parallel intakes (see fig. 29). The present upcast shaft, however, will become downcast and will connect to the intake system at point 3 through the old coal slope, which is not connected to old workings.

To ventilate the old returns and bleed old workings, approximately 5,000 c.f.m. intake air will be regulated into the parallel returns on each side of intake entries near point 3. Normal air leakage is expected to be 100 percent of face requirements.

The air density will be at standard 0.075 p.c.f. The first step is to determine resistance factors for the proposed air circuit. From the pressure gradient (fig. 30), both the air quantities and pressure losses between points can be determined.

CALCULATION OF R FACTORS

1. Intake through slope and rock slope to point 3.

2. Intake from old shaft and coal slope to point 3.

The resistance factors are calculated from the common formula $H=RQ^2$, $R=\frac{H}{Q^2}$, where Q is the actual air quantity c.f.m. divided by 100,000.

From the pressure gradient, the pressure loss H through the rock slope to point 3 is 0.12 inch for 45,000 c.f.m.;

$$R = \frac{0.12}{(0.45)^2} = \frac{0.12}{0.2025} = 0.59.$$

The resistance factor for the second intake can be determined from the present return system.

The resistance factor for segments 10-11 and 11-12 should be calculated separately and added for total resistance.

Segment 10-11:

$$H = 4.60 - 4.30 = 0.30 \text{ inch water,}$$

$$q = 45,000 \text{ c.f.m.,}$$

$$R = \frac{0.30}{(0.45)^2} = \frac{0.30}{0.2025} = 1.48.$$

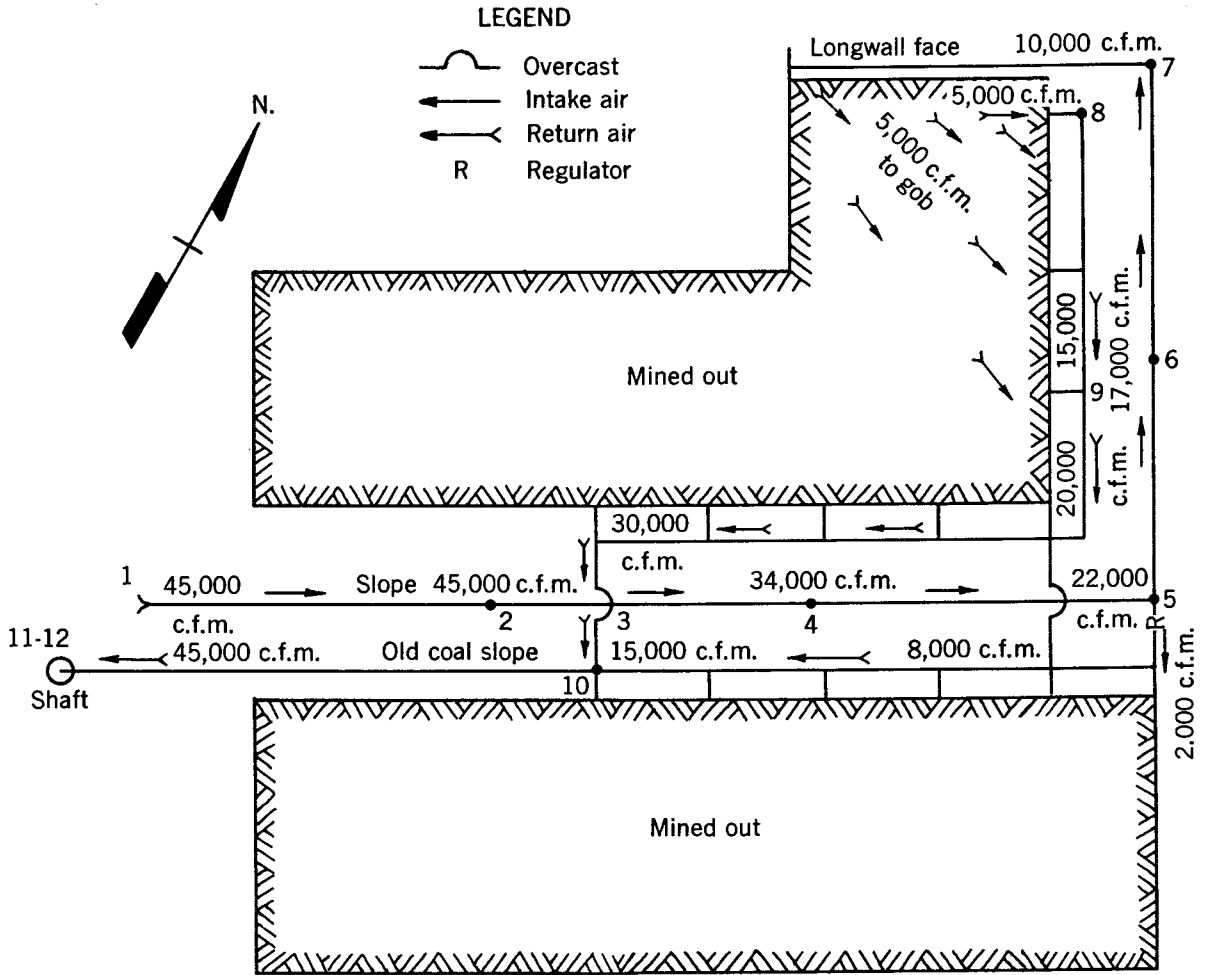

FIGURE 29.—Line Diagram. Problem 4.

Segment 11-12:

$$H = 5.50 - 4.60 = 0.90 \text{ inch water,}$$

$$q = 45,000 \text{ c.f.m.}$$

$$R = \frac{0.30}{(0.45)^2} = \frac{0.30}{0.2025} = 4.44.$$

Total R , points 10-12 = $1.48 + 4.44 = 5.92$.

Parallel flow is determined from the conductance formula

$$\frac{1}{\sqrt{R}} = \frac{1}{\sqrt{R_1}} + \frac{1}{\sqrt{R_2}} + \frac{1}{\sqrt{R_3}};$$

therefore

R_1 equals resistance through rock slope to

point 3; R_2 equals resistance points 10-12; points 10 and 3 will become the same.

$$\frac{1}{\sqrt{R}} = \frac{1}{\sqrt{0.59}} + \frac{1}{\sqrt{5.92}},$$

$$\frac{1}{\sqrt{R}} = \frac{1}{0.768} + \frac{1}{2.43},$$

$$\frac{1}{\sqrt{R}} = 1.30 + 0.41 = 1.71,$$

$$\sqrt{R} = \frac{1}{1.71} = 0.585,$$

$$R = (0.585)^2 = 0.342.$$

The combined R factor 0.342 is for the coal and rock slopes from the surface to point 3 of the ventilating pressure gradient.

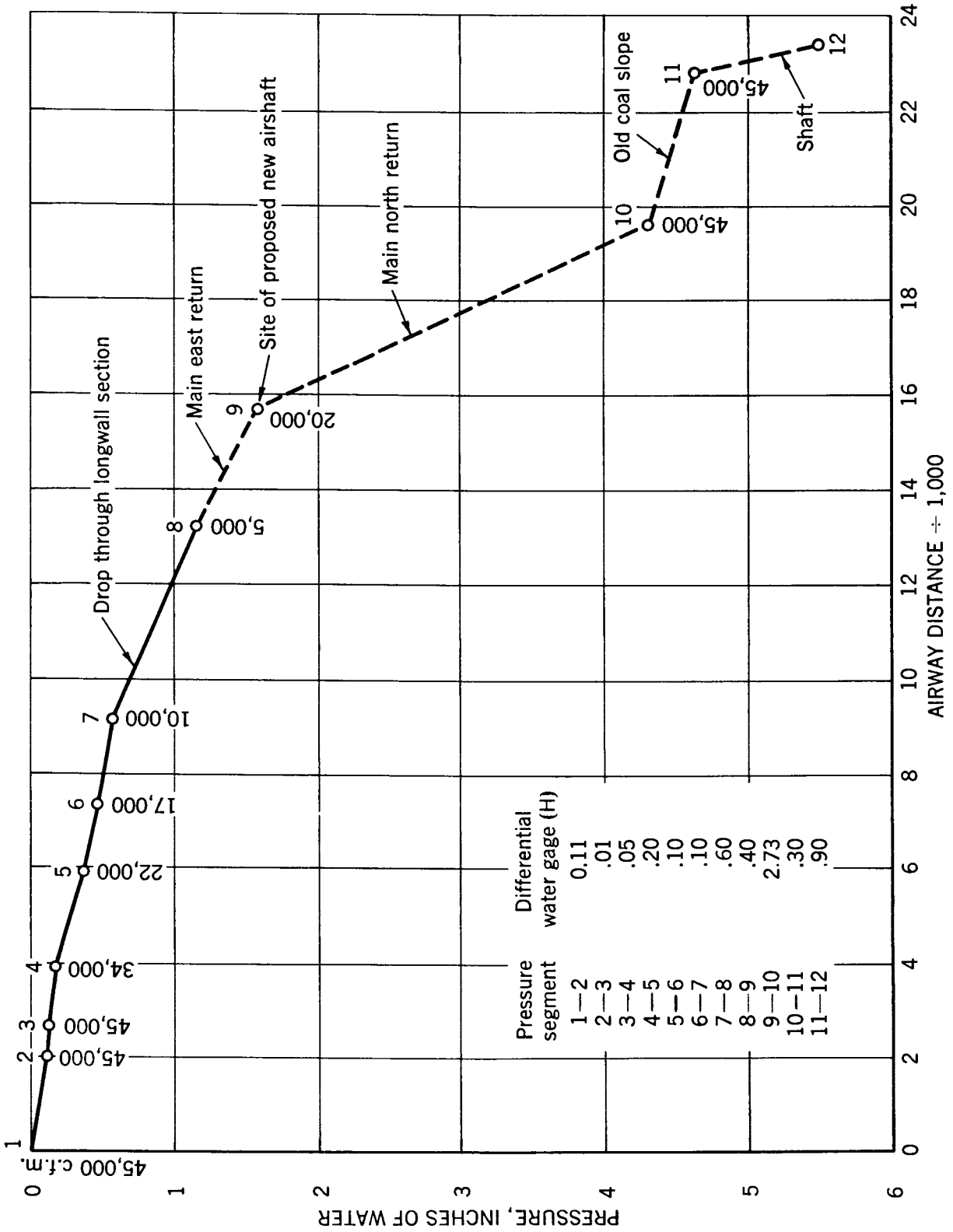

FIGURE 30.—Pressure Gradient. Problem 4.

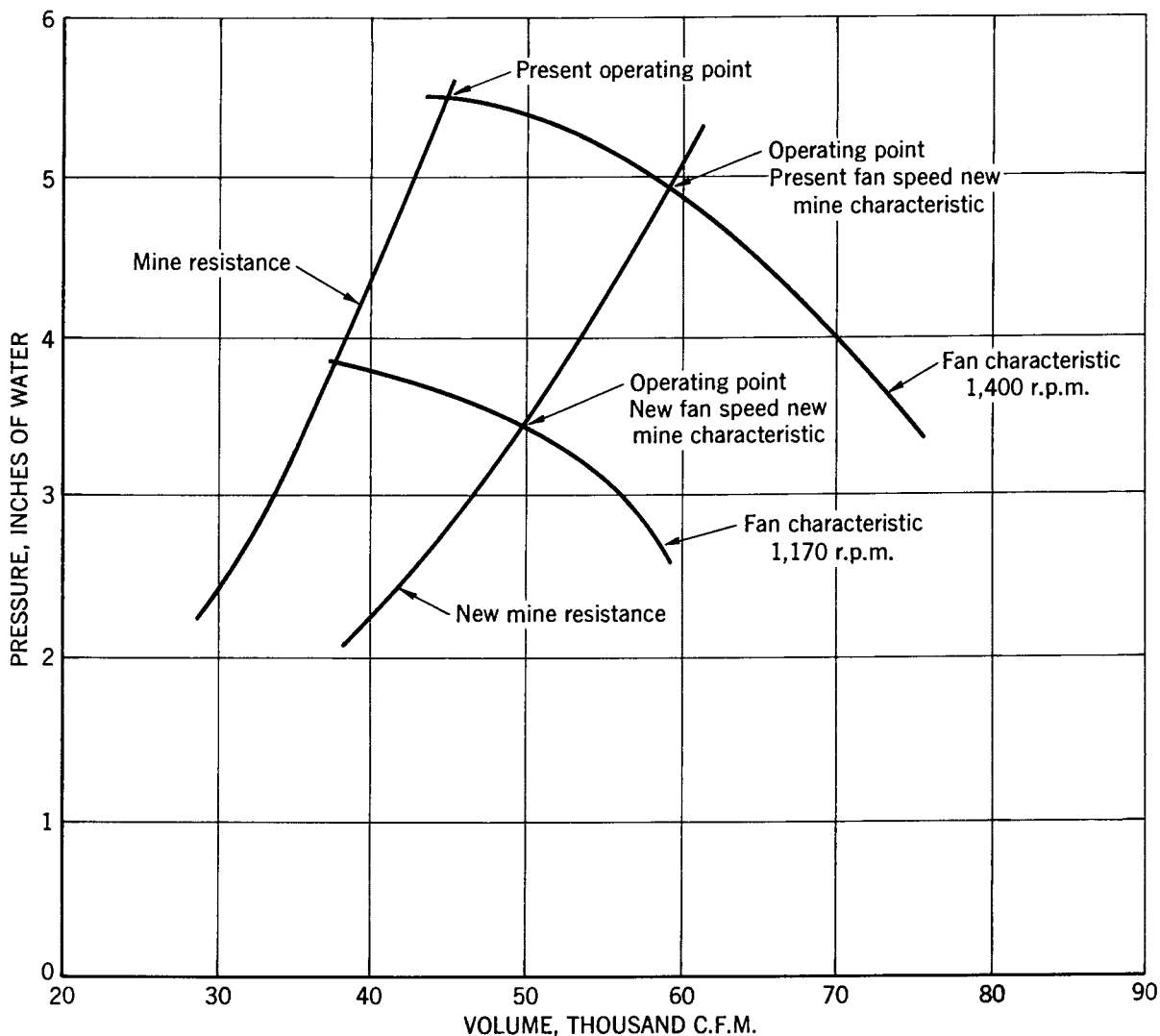

FIGURE 31.—Graph of Fan Data. Problem 4.

Calculating other resistance factors—

Points 3-4:

$H=0.05$ inch water from gradient,

$q=39,500$ c.f.m. average,

$$R = \frac{0.05}{(0.395)^2} = \frac{0.05}{0.156} = 0.321.$$

Points 4-5:

$H=0.20$ inch water from gradient,

$q=28,000$ c.f.m. average,

$$R = \frac{0.20}{(0.28)^2} = \frac{0.20}{0.0784} = 2.55.$$

Points 5-6:

$H=0.10$ inch water from gradient,

$q=18,500$ c.f.m. average,

$$R = \frac{0.10}{(0.185)^2} = \frac{0.10}{0.0324} = 2.92.$$

Points 6-7:

$H=0.10$ inch water from gradient,

$q=13,500$ c.f.m. average,

$$R = \frac{0.10}{(0.135)^2} = \frac{0.10}{0.182} = 5.49.$$

Points 7-8:

$H=0.60$ inch water from gradient,

$q=7,500$ c.f.m. average,

$$R = \frac{0.60}{(0.075)^2} = \frac{0.60}{0.0056} = 107.0.$$

Points 8-9:

$H=0.40$ inch water from gradient,

$q=10,000$ c.f.m. average,

$$R = \frac{0.40}{(0.10)^2} = \frac{0.40}{0.01} = 40.00.$$

Proposed new shaft, 10 feet in diameter, unlined in sedimentary rocks. $K=85$ (see table 5), $l=500$ feet:

$$A = 78.5 \text{ sq. ft.},$$

$$O = 31.4 \text{ ft.},$$

$$R = \frac{KLO}{5.2A^3} = \frac{85 \times 500 \times 31.4}{5.2 \times 79 \times 79 \times 79} = 0.52.$$

CALCULATIONS

Air quantity required:		<i>C.f.m.</i>
Face ventilation, $10,000 \times 2$	-----	20,000
Leakage, 100 percent $\times 20,000$	-----	20,000
Ventilation old works	-----	10,000
Total	-----	50,000

Pressure requirements

Segment	R factor	Q_1	Q_2	Leakage	Average Q	Average Q_2	H	H_r
0-3	0.34	0.50	0.50	-----	0.50	0.250	0.09	-----
3-4	.32	.40	.38	0.02	.39	.152	.05	0.14
4-5	2.55	.38	.35	.03	.37	.137	.35	.49
5-6	2.92	.35	.25	.10	.30	.090	.26	.75
6-7	5.49	.25	.20	.05	.23	.053	.29	1.04
7-8	107.00	1.10	.05	.05	.08	.006	.64	1.68
8-9	40.00	2.15	.25	.10	.20	.04	1.60	3.28
New shaft	.52	3.50	.50	-----	.50	.25	1.13	3.41

¹ Air quantity, 1 active face; other active face assumed to be similar.
² Includes return from 2 active faces.
³ Includes all return and leakage.

The new horsepower will be:

$$\text{hp.} = 3.41 \times 50,000 \div 6,350 = 26.8.$$

Calculate new mine resistance:

$$H = RQ^2, \text{ } H=3.41, \text{ } Q=0.50,$$

$$R = \frac{H}{Q^2} = \frac{3.41}{(0.50)^2} = 13.64.$$

Using the new R factor (13.64) and the $H=RQ^2$, calculate several pressure values using different quantities:

Volume Q	R	Pressure $H=RQ^2$
0.40	13.64	2.18
.45		2.76
.50		3.41
.55		4.13

Plot these data (fig. 31) to obtain the new mine-characteristic curve.

The intersection of this curve with the present fan characteristics shows the benefit derived by decreasing the mine resistance. Instead of 45,000 c.f.m. at 5.5 inches, the fan would now deliver approximately 60,000 c.f.m. at 4.90 inches. However, since the mine requires only 50,000 c.f.m. at 3.41 inches, the new fan speed can be calculated by using the fan laws for speed and pressure or quantity; that is, pressure varies as the square of the fan speed, or quantity varies directly as the fan speed.

Calculation with pressures:

$$\frac{H_1}{H_2} = \left(\frac{S_1}{S_2}\right)^2, \frac{4.90}{3.41} = \left(\frac{1,400}{S_2}\right)^2,$$

$$S_2 = \sqrt{\frac{(1,400)^2 \times 3.41}{4.9}} = 1,400 \sqrt{\frac{3.41}{4.9}}$$

$$= 1,400 \times 0.834,$$

$$= 1,170 \text{ r.p.m. (approx.)},$$

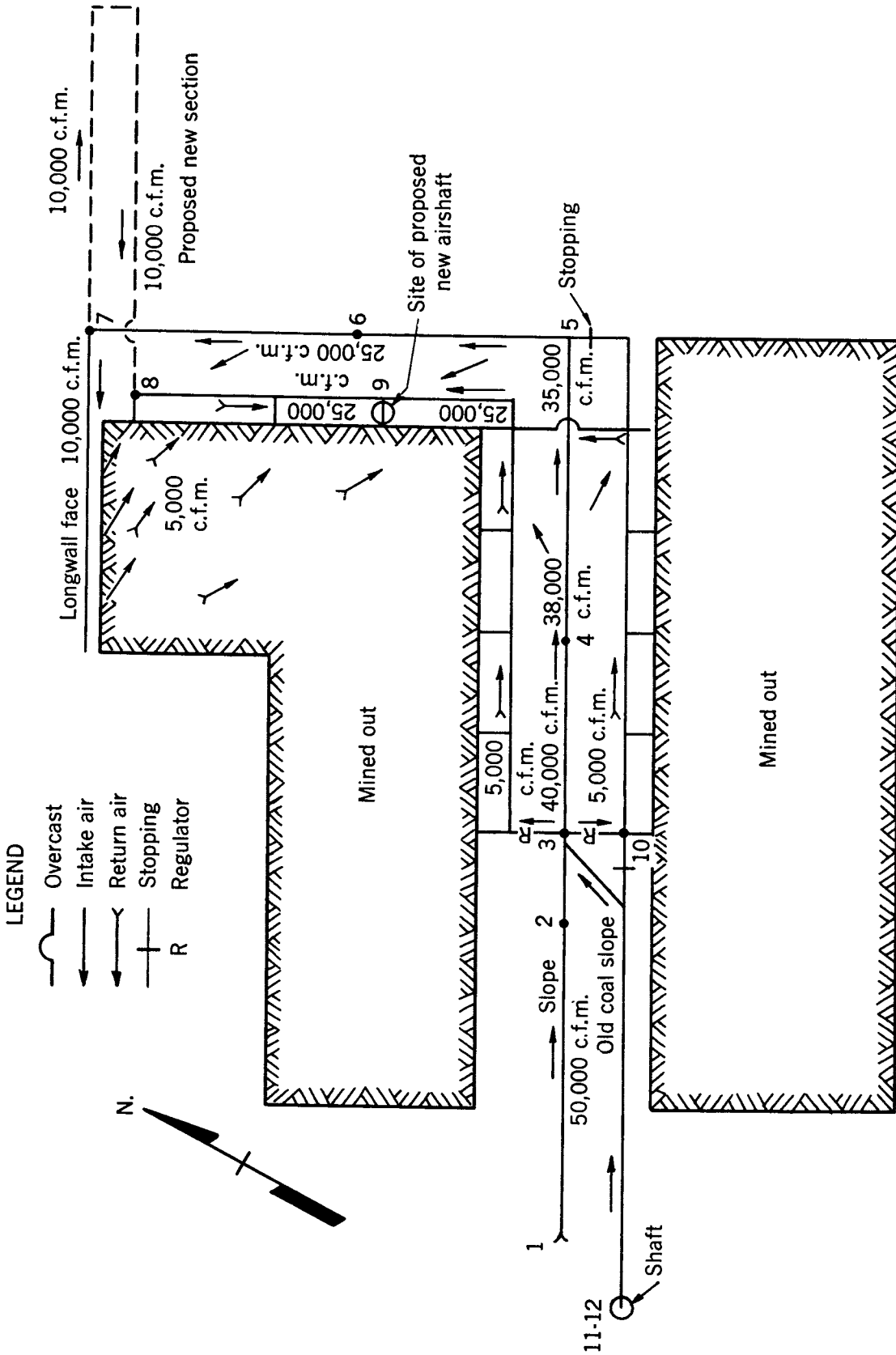

FIGURE 32.—Line Diagram With New Airshaft, Problem 4.

Calculation with quantities:

$$\frac{Q_1}{Q_2} = \frac{S_1}{S_2}$$

$$\frac{60,000}{50,000} = \frac{1,400}{S_2}$$

$$S_2 = \frac{1,400 \times 50,000}{60,000}$$

$$S_2 = 1,170 \text{ r.p.m. (approx.)}$$

If a fan-characteristic curve for 1,200 r.p.m. is not available, the necessary points of a curve at 1,170 r.p.m., for example, can be calculated by using the previously mentioned fan laws and the 1,400-r.p.m. characteristic (fig. 31).

Pressure volume characteristic

Fan operating at 1,400 r.p.m.		Fan operating at 1,170 r.p.m.	
Volume, c.f.m.	Pressure H_1 , inches water	Volume, c.f.m.	Pressure H_2 , inches water
q		c.f.m. $\left(\frac{1,170}{1,400}\right) \times q_1$	$\left(\frac{1,170}{1,400}\right)^2 \times H_1$
45,000	5.5	37,600	3.84
50,000	5.4	41,800	3.77
55,000	5.2	46,000	3.63
60,000	4.9	50,100	3.42
65,000	4.5	54,300	3.14
70,000	4.0	58,500	2.79

The intersection of this curve with the new mine-resistance curve indicates the pressure and quantity at which the fan will operate.

Figure 32 is the new line diagram showing the proposed distribution of air.

VENTILATION REFERENCE MATERIAL

The following reference material is listed for those desiring a more comprehensive reference to certain phrases of mine ventilation:

- BARENBRUG, A. W. T. Psychrometry and Psychrometric Charts. Transvaal and Orange Free State Chamber of Mines, Johannesburg (South Africa), 1955.
- BEARD, J. T. Mine Gases and Ventilation of Mines. McGraw-Hill, New York, N.Y., 2d ed., 1920, 433 pp.
- BROMILOW, JOHN G. Ventilation of Deep Coal Mines. Iron and Coal Trades Rev., vol. 170, 1955; Feb. 11, pp. 303-308; Feb. 18, pp. 367-376; Feb. 25, pp. 427-435.
- . Ventilation of Coal Mines. Inst. of Heat. and Vent. Eng. Jour., vol. 19, No. 199, March 1957.
- CALLEN, A. C., and SMITH, C. M. Measurement of Air Quantities and Energy Losses in Mine Entries. Parts I, II, III. Univ. Illinois Exp. Sta. Bull. 158, 1926; Bull. 170, 1927; Bull. 184, 1928.
- COLLIERY ENGINEERING. Velocity and Energy of Mine Air. Vol. 19, No. 215, January 1942, pp. 9-12.
- COOKE, W. E. Natural Ventilation. Coll. Eng., vol. 11, No. 129, November 1934, pp. 375-378.
- . Ventilation Economics. Coll. Eng., vol. 35, No. 413, July 1958, pp. 289-294.
- FLUGGE-DE SMIDT, R. A. H. Notes on Fan Pressures. Jour. Chem. Met. Min. Soc. South Africa, vol. 56, No. 9, March 1956, pp. 325-330.
- GREENWALD, H. P., and McELROY, G. E. Coal Mine Ventilation Factors. Bureau of Mines Bull. 285, 1929, 106 pp.
- HINSLEY, F. B. The Determination of Pressure Losses in Mine Shafts. Trans. Inst. of Min. Eng., vol. 108, 1949, pp. 613-627.
- MACWILLIAMS, F. FRASER. Power Savings Made by Careful Study of Ventilating Plans. Coal Age., vol. 44, September 1939, p. 35.
- MANCHA, RAYMOND. Pitot Tube Field Tests of Axial-Flow Mine Fans. AIME Tech. Paper 1425.
- MARVIN, C. F. Psychrometric Tables for Obtaining the Vapor Pressure, Relative Humidity, and Temperature of the Dew-Point. U.S. Weather Bureau Pub. 235, 1915.
- McELROY, G. E. Mine-Air Flow. Trans. AIME, vol. 74, 1926, pp. 297-311.
- . Engineering Factors in the Ventilation of Metal Mines. Bureau of Mines Bull. 385, 1935, 196 pp.
- . Historical Résumé of Mine and Tunnel Ventilation Studies, 1910-49. Bureau of Mines Inf. Circ. 7556, 1950, 16 pp.
- McELROY, G. E., and RICHARDSON, A. S. Determining the Airflow Resistance of a Small Shaft Mine by Natural Draft. Bureau of Mines Rept. of Investigations 2890, 1928, 15 pp.
- . Experiments on Mine-Fan Performance. Bureau of Mines Tech. Paper 447, 1929, 61 pp.
- PEELE, ROBERT. Mining Engineers' Handbook. John Wiley & Sons, New York, N.Y., 1941.
- PENMAN, D., and PENMAN, J. S. The Principles and Practice of Mine Ventilation. C. Griffin (London), 2d ed., 1947, 337 pp.
- PRODUCTION ENGINEERING. Guide to Fan Selection. Vol. 29, No. 17, Apr. 28, 1958.
- RABSON, S. R. Elementary Notes on Flow of Air and Atkinson's Formula. Jour. Min. Vent. Soc. South Africa, vol. 11, No. 2, December 1958.
- ROGERS, A. W. Features of Axial Flow Fans. Air Cond. Heat. and Vent., vol. 55, January 1958.
- SAXE, J. H. Value of Ventilation Surveys. Coal Mining, vol. 24, January 1947.
- TONER, R. Fundamental Fan Laws. Power and Works Eng., vol. 52, No. 609, March 1957.
- TRICKLER, C. J. Fan Laws and System Curves. Heat. Pip. and Air Cond., vol. 28, December 1956, pp. 105-106.
- UTAH UNIVERSITY ENGINEERING EXPERIMENT STATION. Fan Performance and Selection Using Dimensionless Ratio. Bull. 66, May 1954.
- WILLIAMSON, J. N. How to Measure Pressure Losses in Ventilation. Coal Age, vol. 37, August 1932, pp. 297-298.
- . How to Make Air Survey and Calculate Results. Coal Age, vol. 37, September 1932, pp. 331-333.