

RI 9291

REPORT OF INVESTIGATIONS/1990

In-Mine Test of the Bureau of Mines Preproduction Wireless Survey System

By Stephen J. Kravits and John Millhiser

1910 ★ **80** ★ 1990
YEARS

BUREAU OF MINES



UNITED STATES DEPARTMENT OF THE INTERIOR

Mission: As the Nation's principal conservation agency, the Department of the Interior has responsibility for most of our nationally-owned public lands and natural and cultural resources. This includes fostering wise use of our land and water resources, protecting our fish and wildlife, preserving the environmental and cultural values of our national parks and historical places, and providing for the enjoyment of life through outdoor recreation. The Department assesses our energy and mineral resources and works to assure that their development is in the best interests of all our people. The Department also promotes the goals of the Take Pride in America campaign by encouraging stewardship and citizen responsibility for the public lands and promoting citizen participation in their care. The Department also has a major responsibility for American Indian reservation communities and for people who live in Island Territories under U.S. Administration.

Report of Investigations 9291

**In-Mine Test of the Bureau of Mines
Preproduction Wireless Survey
System**

By Stephen J. Kravits and John Millhiser

**UNITED STATES DEPARTMENT OF THE INTERIOR
Manuel Lujan, Jr., Secretary**

**BUREAU OF MINES
T S Ary, Director**

Library of Congress Cataloging in Publication Data:

Kravits, S. J. (Stephen J.)

In-mine test of the Bureau of Mines preproduction wireless survey system / by Stephen J. Kravits and John Millhiser.

p. cm. - (Report of investigations; 9291)

Includes bibliographical references.

1. Coalbed methane drainage--Directional drilling. 2. Boring. I. Millhiser, John. II. Title. III. Title: Wireless survey systems. IV. Series: Report of investigations (United States. Bureau of Mines); 9291.

TN23.U43 [TN844.5] 622 s--dc20 [622'.82] 89-600247
CIP

CONTENTS

	<i>Page</i>
Abstract	1
Introduction	2
Acknowledgments	2
General description of wireless survey system operation	3
Wireless survey system in-mine test	6
Test site	6
Directional drilling equipment	6
Hydraulic drill	8
Downhole motor	8
Wireless survey system time study	8
Problems encountered	10
Conclusions	11
References	12
Appendix.—Electronic design, mechanical design, operation of wireless survey system, and recommendations	13

ILLUSTRATIONS

1. Time required to survey versus borehole depth	2
2. Downhole guidance probe	3
3. Uphole receiving transformer and uphole receiver processor	4
4. WSS operational schematic	5
5. Hydraulic drill feed frame	6
6. Downhole motor	7
7. Triple piston pumps	8
8. Plan view of horizontal borehole	9
9. Vertical section of horizontal borehole	9
9. Comparison of available drilling time with WSS and wire-run survey instrument	11
A-1. WSS block diagram	13
A-2. Downhole guidance probe block diagram	14
A-3. Sensor package and canister	14
A-4. Signal processing and transmission circuitry	15
A-5. Current inducing transmitter	17
A-6. Sealed lead acid batteries	17
A-7. Battery pack	18
A-8. Sensor canister and outer collar	18
A-9. Uphole receiving transformer block diagram	19
A-10. Uphole receiving transformer	19
A-11. Uphole receiving transformer and gas handling equipment	20
A-12. Uphole receiver processor showing operating display	21
A-13. Uphole receiver processor block diagram	21
A-14. Uphole receiver processor	22

TABLES

1. WSS time study	10
A-1. Specifications of Develco	13
A-2. Downhole guidance probe channel assignment	16
A-3. A-D converter scaling factors	16
A-4. Power amplifier and downhole guidance probe output	16

UNIT OF MEASURE ABBREVIATIONS USED IN THIS REPORT

A	ampere	mA · h	milliampere hour
A · h	ampere hour	MHz	megahertz
A · h/d	ampere hour per day	mV	millivolt
dB	decibel	min	minute
°C	degree Celsius	ms	millisecond
ft	foot	pct	percent
G	gauss	psig	pound (force) per square inch, gauge
gpm	gallon per minute	s	second
Hz	hertz	s/h	second per hour
h	hour	V	volt
hp	horsepower	V ac	volt, alternating current
in	inch	V dc	volt, direct current
kHz	kilohertz	V/G	volt per gauss
lb	pound	W	watt
mA	milliampere		

IN-MINE TEST OF THE BUREAU OF MINES PREPRODUCTION WIRELESS SURVEY SYSTEM

By Stephen J. Kravits¹ and John Millhiser²

ABSTRACT

The U.S. Bureau of Mines preproduction Wireless Survey System (WSS) and its performance during an in-mine test are discussed in this report. The WSS was developed to reduce downhole surveying time in order to increase the efficiency of drilling long horizontal methane drainage boreholes in coal. Borehole survey data are electromagnetically transmitted from the WSS's downhole guidance probe, via the drill rod, to the uphole subsystem in less than 1 min per survey transmission, regardless of borehole depth. The WSS's in-mine test consisted of providing borehole survey data during the directional drilling of a 2,538-ft horizontal methane drainage borehole in the Pittsburgh Coalbed. By considering available drilling time, which does not include hydraulic drill downtime and the time spent traveling portal to portal, 24 shifts were needed to complete the borehole. Of the available drilling time during the test, 50 pct of the time was spent drilling and 50 pct surveying and maintaining the WSS to keep it operational. Previous Bureau experience indicates drilling efficiency was increased 108 pct because of the WSS, in comparison with using a commercially available wire-run directional survey instrument at 10-ft intervals.

¹Mining engineer, Pittsburgh Research Center, U.S. Bureau of Mines, Pittsburgh, PA.

²President, ISE, Inc., Aldie, VA.

INTRODUCTION

The U.S. Bureau of Mines pioneered the development and has demonstrated that the technique of methane control by horizontal boreholes is an effective method for removing methane from coalbeds in advance of mining and controlling methane emissions during mining (1-4).³ For horizontal boreholes to be effective, they must be accurately drilled simultaneously maintaining vertical trajectory within the coalbed and horizontal trajectory on the desired course. Maintaining this degree of drilling accuracy can be difficult, requiring frequent directional surveys of bit inclination and azimuth, usually at 10- to 20-ft drilling intervals. The time required to survey at this frequency using conventional wire-run survey instruments increases with borehole depth (fig. 1). Previous Bureau experience with boreholes drilled to depths of 1,000 ft or greater has shown that the time spent surveying can occupy as much time as the drilling operation (5-6). Consequently, drilling productivity is reduced as the time required to survey increases. To address this problem, the Bureau developed a preproduction WSS.

This report provides a description of the WSS and its performance during an in-mine test. Electronic and mechanical design information concentrating on the WSS operation and assembly are provided in detail in an appendix along with suggested design modifications for a production model WSS.

ACKNOWLEDGMENTS

The cooperation provided by personnel at BethEnergy Mines, Inc.'s, Eighty-Four Complex, Livingston Portal, Eighty Four, PA, was critical to the successful in-mine test of the preproduction WSS. In particular, special thanks

³Italic numbers in parentheses refer to items in the list of references preceding the appendix.

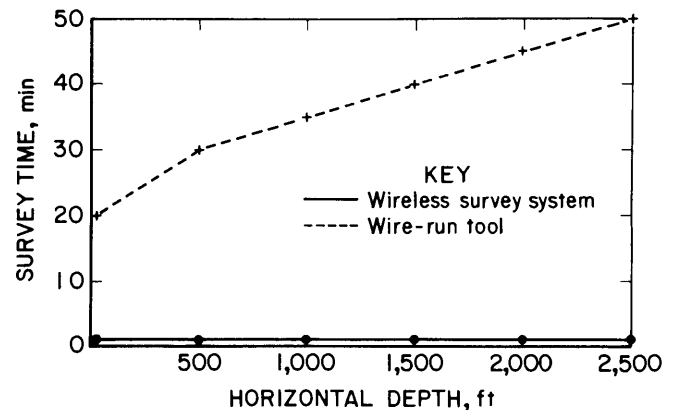

Figure 1.—Time required to survey versus borehole depth for the permissible wire-run survey instrument and WSS.

are dedicated to Donald Raab, mining engineer, coordination of mine personnel duties; John Ronto, construction foreman, drill site preparation; Thomas Decass, surveying engineer, drill site preparation; and Thomas Mucho, mine manager, project approval and assignment of mine personnel; of BethEnergy Mines, Inc., Eighty-Four Complex.

GENERAL DESCRIPTION OF WIRELESS SURVEY SYSTEM OPERATION

The Bureau's WSS is composed of a downhole guidance probe (fig. 2), an uphole receiving transformer, and an uphole receiver processor (fig. 3). The downhole guidance probe is positioned directly behind the downhole motor, thus becoming an integral part of the drill string. Sensors, electronics, batteries, and a transmitter make up the downhole guidance probe. As the word uphole implies, the uphole receiving transformer and uphole receiver processor are stationed out of the borehole at the drill site.

The operation of the WSS is illustrated by figure 4. To conduct a survey, the downhole guidance probe is activated by shutting off the high-pressure (500 to 1,000 psig) waterflow powering the downhole motor, which provides bit rotation. A miniature pressure transducer is positioned in the downhole guidance probe's electronics that continuously monitors drilling water pressure. When the pressure transducer measures the drop in water pressure, the electronics switch battery power to the downhole guidance probe's sensors. The sensors determine the position of the probe with respect to the Earth's gravitational and magnetic field vectors. Raw borehole positional data is converted from analog to digital form by the downhole guidance probe's electronics. The downhole guidance probe's transmitter, which is a one-turn toroidal transformer, transmits the data uphole by electromagnetically inducing a current onto the steel drill rod.

Ideally, each end of the drill string, namely, the drill bit and the electrohydraulic drill, should make a hard ground connection. Typically, coalbeds are surrounded above and below by shales, clays, or other materials that are more conductive. Therefore, these materials tend to offer a good return path for the signal between the ends of the drill string. Data or drill string currents are detected by the uphole receiving transformer.

The uphole receiving transformer is a very sensitive current toroidal transformer constructed to allow the drill rod to pass through. After the data signal is amplified, it is transmitted by cable to the uphole receiver processor where it is demodulated. Finally, the processor evaluates and converts the raw data into usable information including inclination, azimuth, orientation of the downhole motor's bent housing and status of the downhole batteries, etc. Inclination, azimuth, and survey depth are entered into a Hewlett Packard⁴ HP-15C calculator programmed with a radius-of-curvature program used to calculate the borehole's elevation and coordinates. Regardless of borehole depth, surveys, take less than 1 min each to complete. The electronic design, mechanical design, operation, and assembly of the WSS are explained in the appendix.

⁴Reference to specific products does not imply endorsement by the U.S. Bureau of Mines.

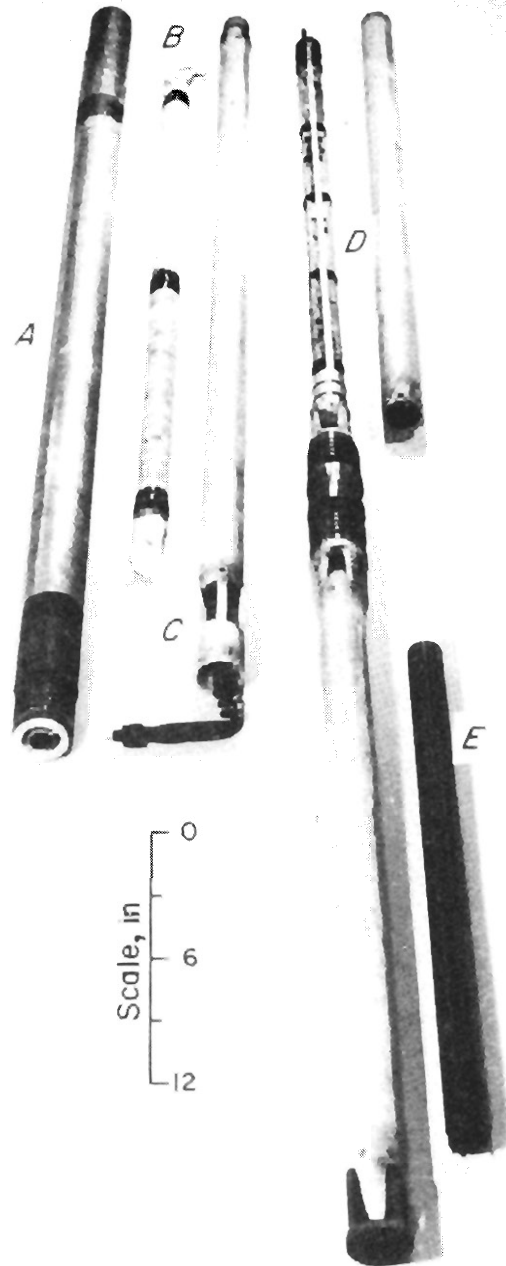

Figure 2.—Downhole guidance probe. A, Transmitter; B, batteries and canister; C, battery-transformer cable; D, electronics and canister; E, sensor package and canister.

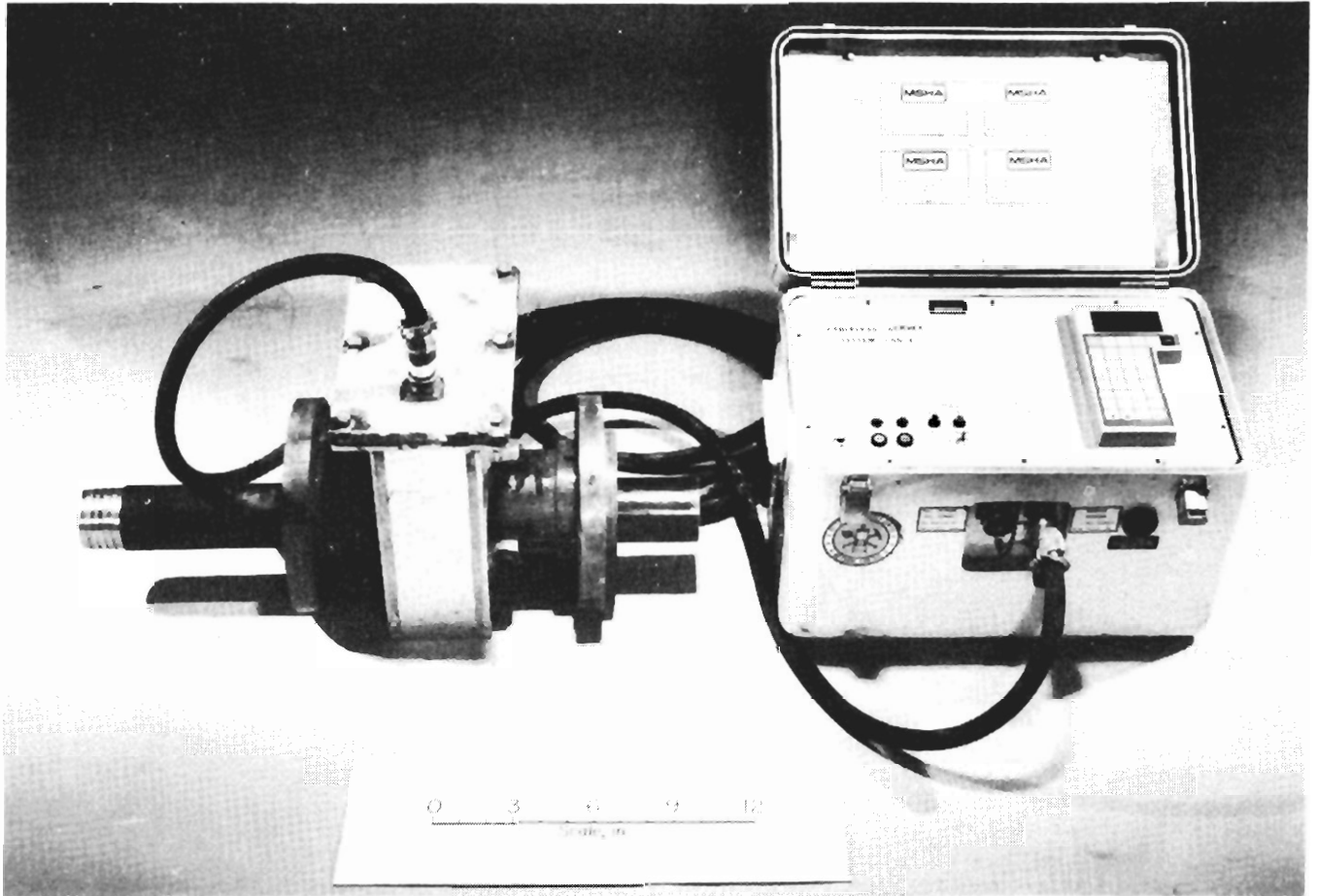

Figure 3.—Uphole receiving transformer (left) and uphole receiver processor (right).

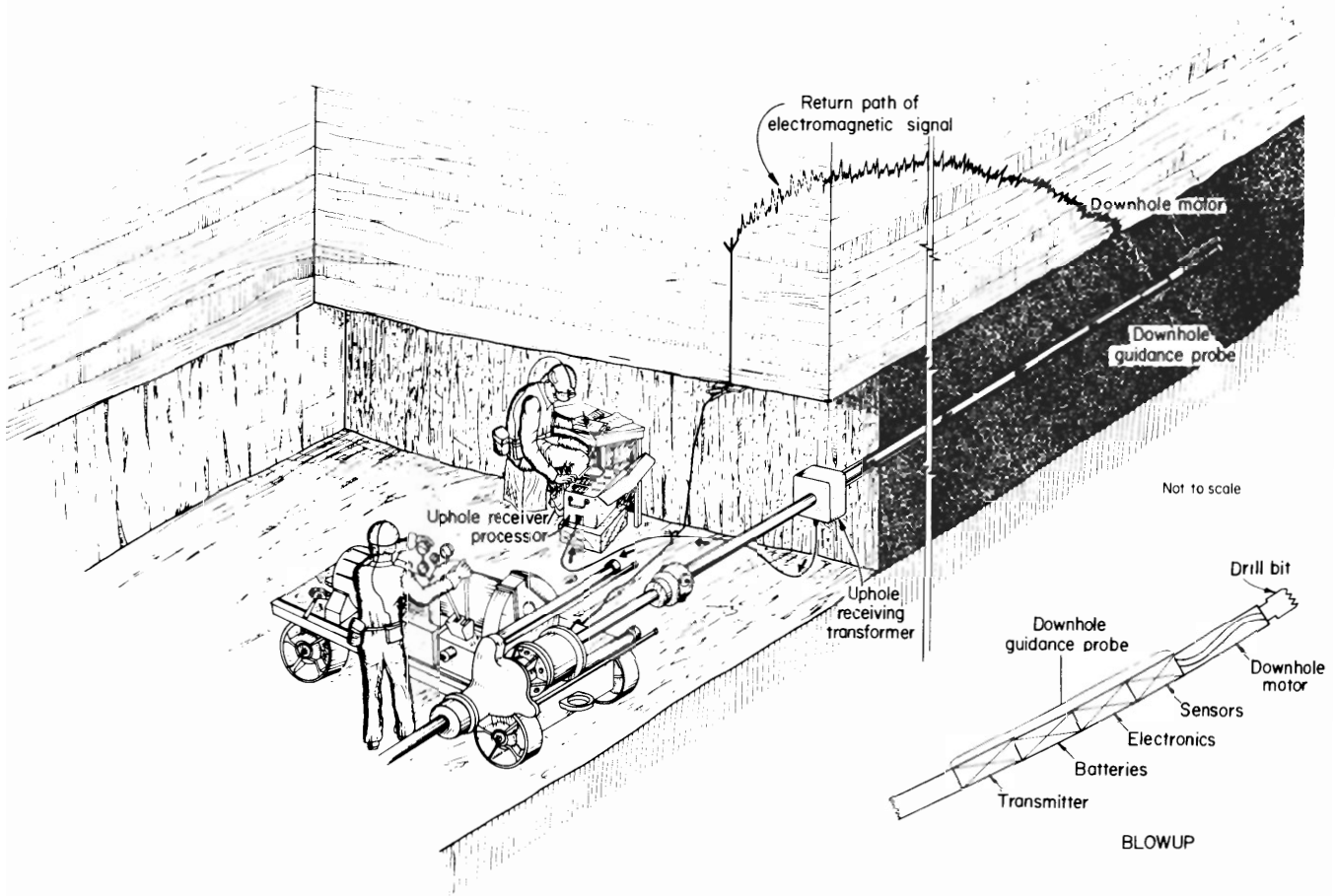

Figure 4.-WSS operational schematic.

WIRELESS SURVEY SYSTEM IN-MINE TEST

TEST SITE

The test site was the B-Left longwall gate road development of BethEnergy Mines, Inc., Eighty-Four Complex. The mining complex is located approximately 2 miles south of Eighty Four, PA, and operates in the Pittsburgh Coalbed, which is approximately 5.5-ft thick. A horizontal methane drainage borehole was drilled in advance of B-Left longwall gate road development to intercept gas cells created by numerous clay veins. Polyethylene pipeline was used to safely transport the methane produced by the horizontal borehole to the return air shaft where it was vented to the surface atmosphere.

DIRECTIONAL DRILLING EQUIPMENT

A Longyear hydraulic drill and a 2.88-in-OD high-torque, nonmagnetic downhole motor manufactured by Slimdril International, Inc., Houston, TX, were used to directionally drill the horizontal methane drainage borehole (fig. 5). The downhole motor was equipped with a 1° bent housing and a Longyear 3.5-in-OD polycrystalline diamond cutter bit (fig. 6).

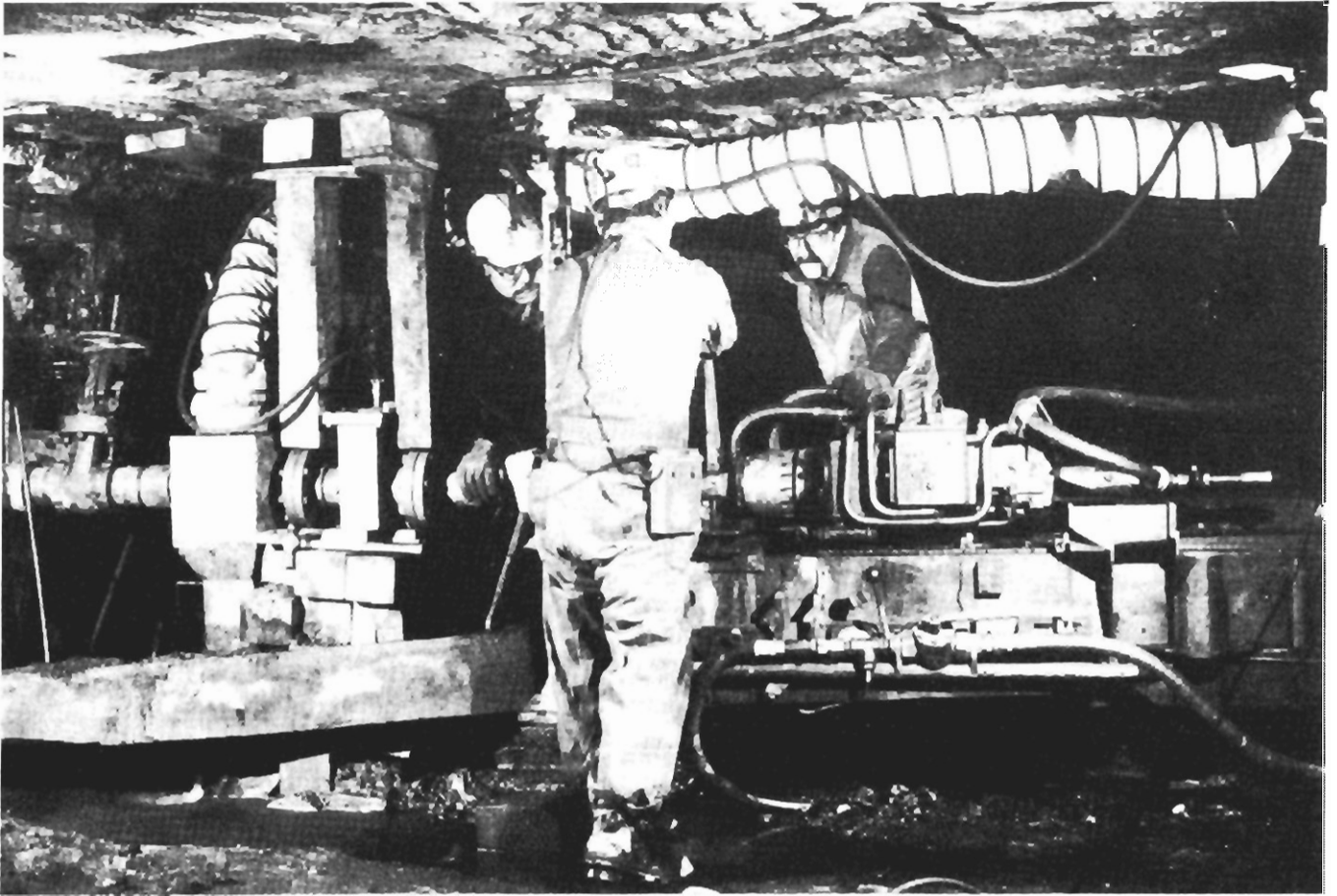

Figure 5.—Hydraulic drill feed frame.

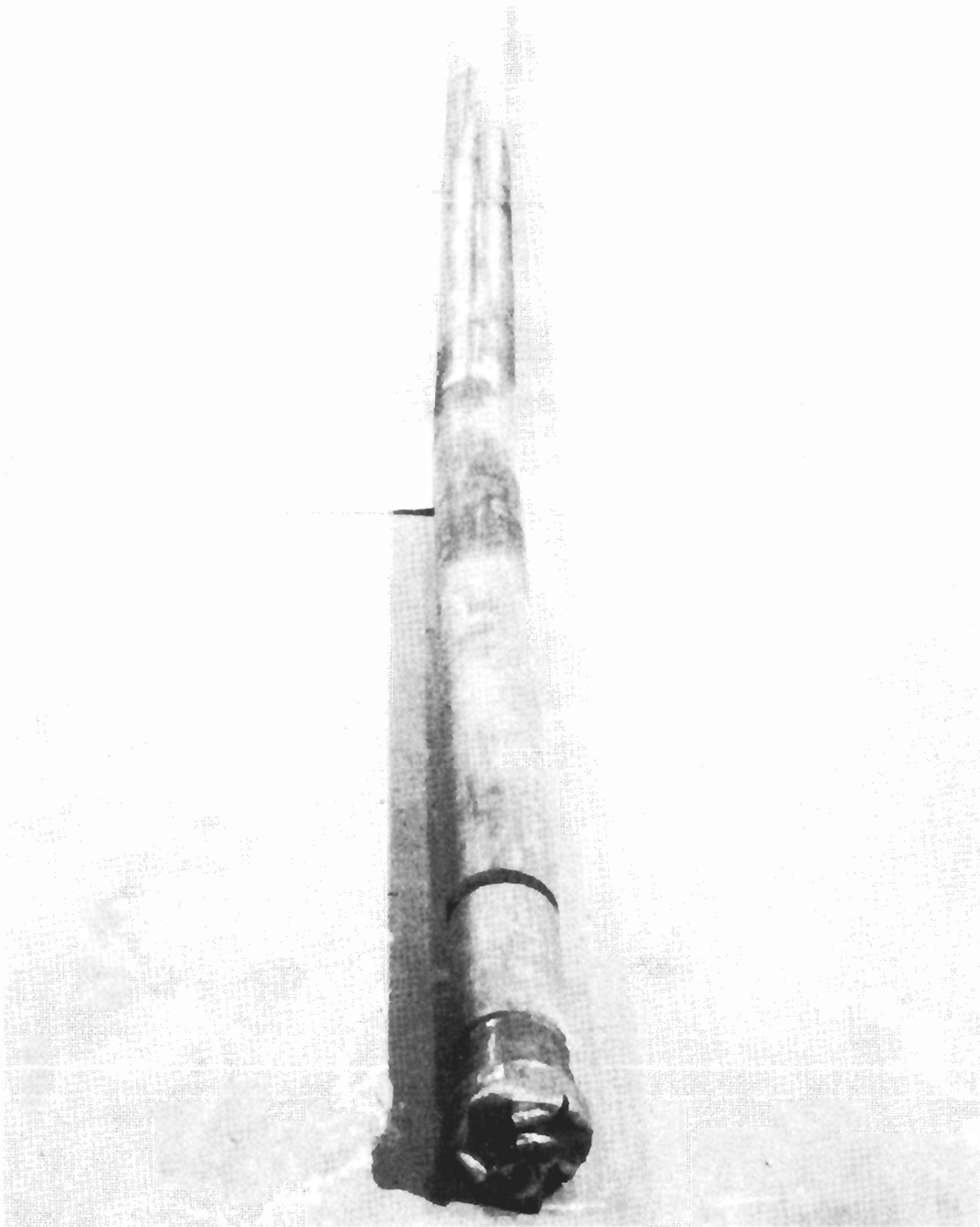

Figure 6.-Downhole motor (shown equipped with 2° bent housing and polycrystalline diamond cutter bit, although 1° bent housing used during in-mine test).

Hydraulic Drill

The main components of the Longyear drill are the drill feed frame-control panel and power unit. The power unit is equipped with two hydraulic radial piston pumps, one for thrust and one for rotation, both powered by a single 40-hp, 440-V ac electric motor. The hydraulic drill was used to maintain hydraulic pressure or thrust on the drill string including drill rod, WSS, and downhole motor equipped with a polycrystalline diamond cutter bit.

Downhole Motor

The downhole motor is a positive displacement hydraulic motor that rotates the drill bit without rotating the drill string. The hydraulic horsepower generated by the flow of the drilling fluid (water) under pressure (65 to 70 gpm, 500 to 1,000 psig) is converted by the downhole motor into torque and rotational speed or mechanical power that

drives the drill bit (fig. 7) (7). Desired vertical horizontal trajectories of the horizontal borehole were maintained by simply aiming the bent housing in the desired orientation measured by the WSS along with inclination and azimuth. A description of the Slimdril components and their operation (7) along with directional drilling procedures for horizontal boreholes have previously been published (6, 8).

WIRELESS SURVEY SYSTEM TIME STUDY

The preproduction WSS provided borehole positional information during the directional drilling of a 2,538-ft horizontal methane drainage borehole. The horizontal borehole was used to shield a longwall gate road development from methane emissions. Figures 8 and 9 illustrate the plan view and vertical section, respectively, of the completed borehole. The in-mine test took 33 shifts to complete, including hydraulic drill downtime, working with one crew, and one 8-h shift per day.

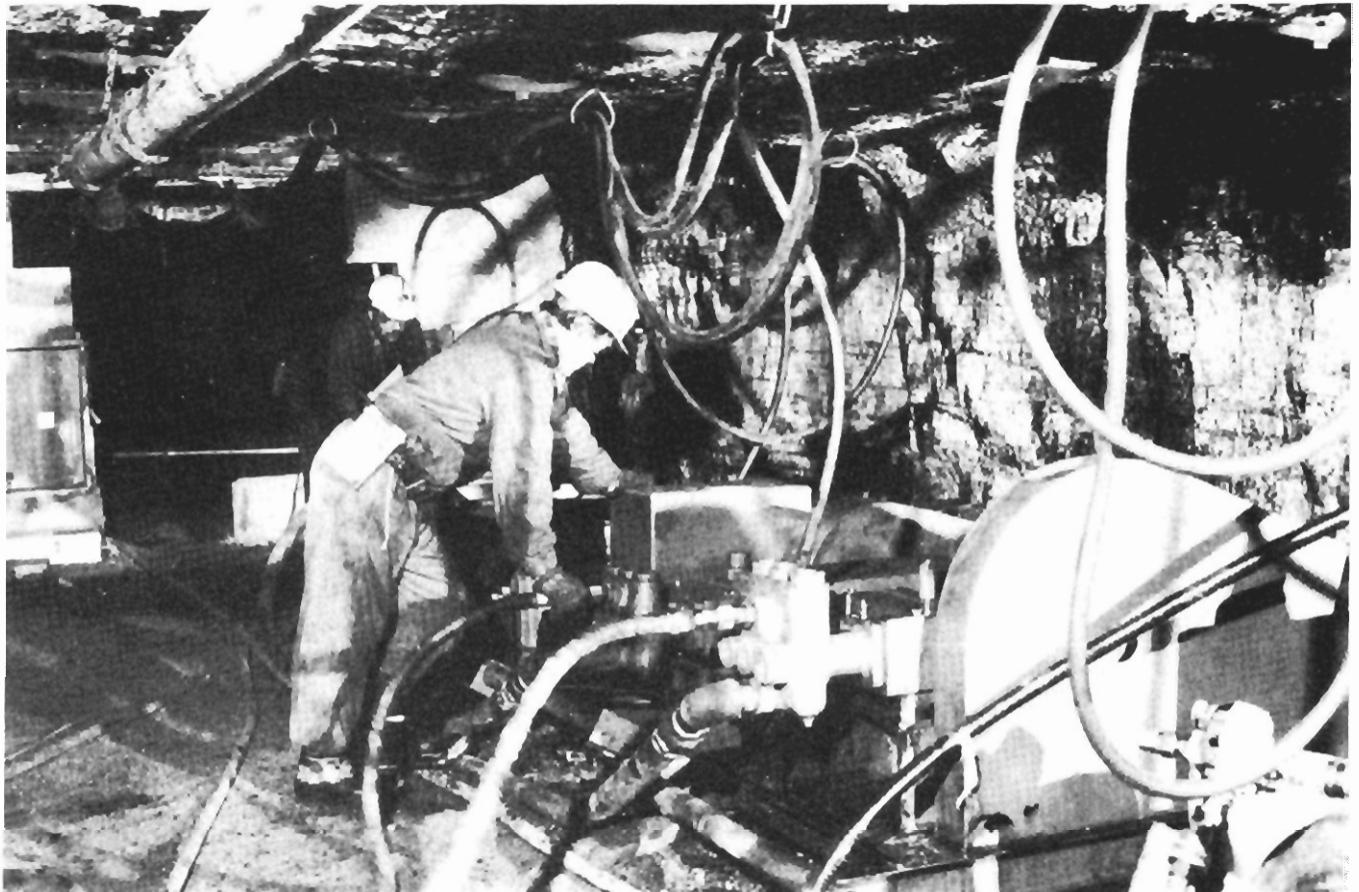

Figure 7.—Triple piston pumps used to supply water flow of 60-70 gpm at 500 to 1,000 psig to power the downhole motor.

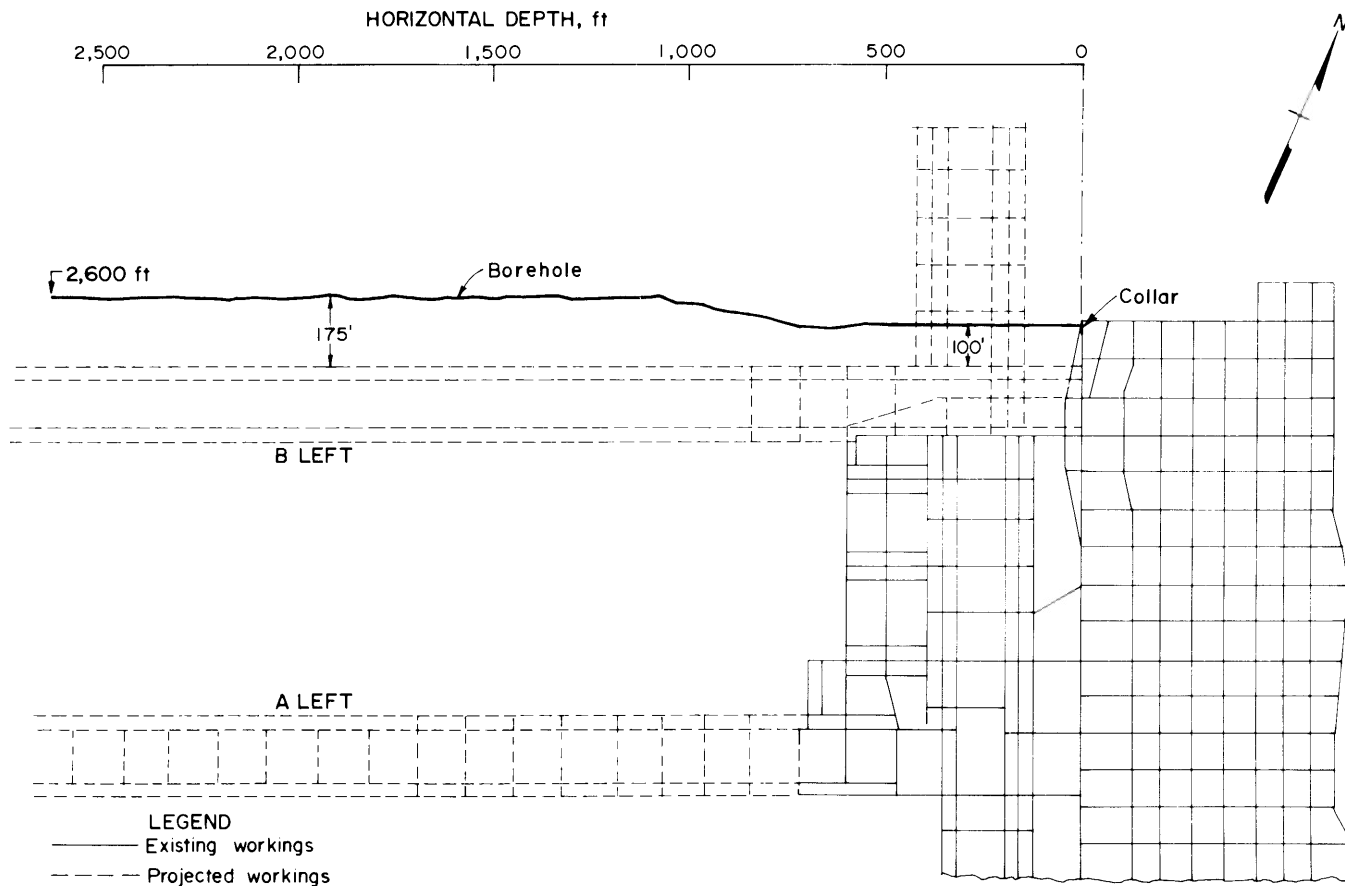

Figure 8.-Plan view of horizontal borehole.

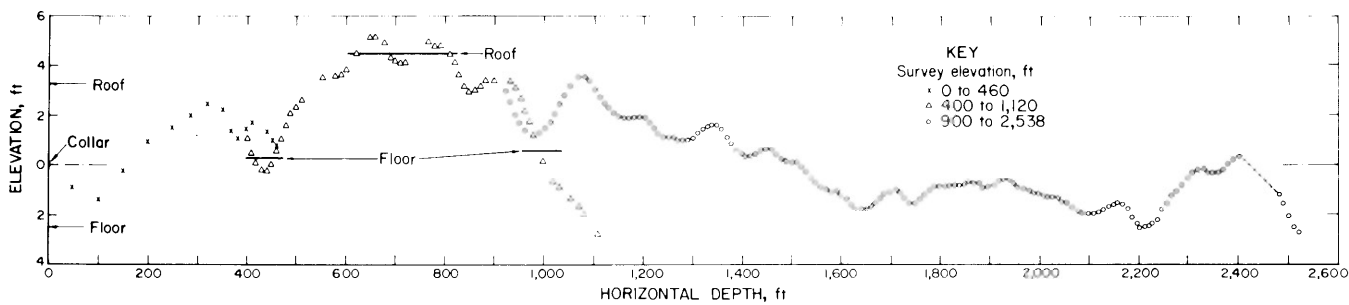

Figure 9.-Vertical section of horizontal borehole.

Table 1 indicates the breakdown of the in-mine test including drilling, surveying, etc. A typical drilling-surveying sequence includes drilling a 10-ft length drill rod, flushing the borehole clean of cuttings, surveying, adding a new drill rod, and reestablishing water circulation to resume drilling. Of the total 33 shifts to complete the borehole, 9 shifts were spent drilling. The WSS downhole guidance probe was designed to be activated when the drilling water pressure is shut off after the completion of a 10-ft drill rod and the borehole has been flushed clean of cuttings.

Table 1.-WSS time study

Operation	8-h, shifts
Drilling	9
Adding drill rod ¹	5
Surveying	1
WSS maintenance:	
Charging batteries ²	6
Downtime	3
Hydraulic drill downtime	9
<u>Total shifts</u>	<u>33</u>

¹Includes flushing borehole clean of cuttings and reestablishing water circulation after new drill rod has been added.

²Includes time spent to pull drill string from borehole to charge downhole guidance probe batteries and time to reinstall downhole guidance probe in borehole.

During the study, a total of 2,898 ft of horizontal borehole was drilled, including 290 ft of sidetracks (fig. 9). Consequently, over 350 WSS surveys were conducted including bad transmissions. A total time of less than one shift was occupied conducting WSS borehole surveys.

Cumulatively, five shifts were required to flush the borehole clean of cuttings after the completion of a drill rod, add a drill rod after a survey was completed, and reestablish water circulation to resume drilling. Regardless of the survey system employed, the borehole must be adequately flushed clean of cuttings after the completion of a drill rod to prevent blockage of cuttings and the drill string getting stuck. However, when using the WSS, extra time and attention was made to ensure that the drill cuttings were removed from the borehole. Coal cuttings in the borehole will couple the drill string and the coalbed, weakening and possibly shorting the data signal transmitted via the drill rod. Of the five shifts spent flushing the borehole, adding a drill rod, etc., two were estimated as required to ensure that the cuttings were removed from the borehole. Consequently, these two shifts were included as WSS surveying time. Maintenance of the WSS occupied a total of nine shifts, six shifts charging the downhole guidance probe batteries and three shifts repairing the steel conduit, which provides access from the sensor package to the downhole electronics.

The downhole guidance probe's battery pack consisted of 14 2.5 A·h, 2.1 V capacity, sealed lead acid batteries. By considering the current draw of a normal day of 0.49 A·h, working one shift per day, the downhole guidance probe had to be pulled out of the borehole about

every 5 days for recharging, or a total of six times during the in-mine test (details concerning current draw of the downhole guidance probe, etc. are discussed in the appendix). The time spent pulling the downhole guidance probe out of the borehole and putting the probe back in the borehole after recharging occupied six shifts. Furthermore, during the six 5-day periods (one shift per day worked) that the downhole guidance probe was operational in the borehole, the hydraulic drill averaged 3.33 days of the 5-day periods, before it needed repair. If the hydraulic drill was not operational, the WSS could not be used even if the WSS worked. Consequently, although the downhole guidance probe was operational in the borehole, it was not used 10 shifts because of hydraulic drill downtime.

The WSS failed only once when a 0.19-in-ID steel conduit (fig. A-3) providing access from the sensor package to the electronics in the downhole guidance probe developed a small crack allowing water to enter the sensor and electronics canisters. Replacing the steel conduit and Develco sensor package that suffered water damage, and making minor repairs to the downhole electronics, took three shifts.

Available drilling time is considered the time available for drilling, not included are hydraulic drill downtime and the time spent traveling portal to portal. To provide a valid comparison between the WSS and the commercially available, permissible wire-run survey instrument, the nine shifts spent maintaining the WSS (six shifts charging downhole batteries and three shifts WSS downtime) and the two shifts required to adequately flush the borehole clean of cuttings, will be considered as surveying time.

Figure 10 illustrates a surveying and drilling comparison of surveying with the WSS and wire-run survey tool while drilling a 2,538-ft horizontal methane drainage borehole. Twelve shifts or 50 pct of the available drilling time, were spent surveying (combining shifts, one surveying, nine maintaining WSS, and two adequately flushing borehole); while 38 shifts or 76 pct were required surveying with the wire-run tool. Therefore, surveying with the WSS was 217 pct more efficient than the wire-run tool. Twenty-four shifts of available drilling time were required to complete the borehole using the WSS compared with 50 shifts with the wire-run tool. Consequently, drilling efficiency or productivity increased 108 pct as a result of surveying with the WSS.

PROBLEMS ENCOUNTERED

To conduct a WSS survey at the completion of a 10-ft drill rod, the borehole must be flushed clean of cuttings. As mentioned earlier, if not flushed adequately, the likelihood of a missed survey or bad data transmission, increases. When the time and difficulty to adequately flush cuttings from the borehole increased with depth, the frequency of bad data transmissions or no transmission of any data, increased, especially from a depth of 2,300 ft to borehole completion.

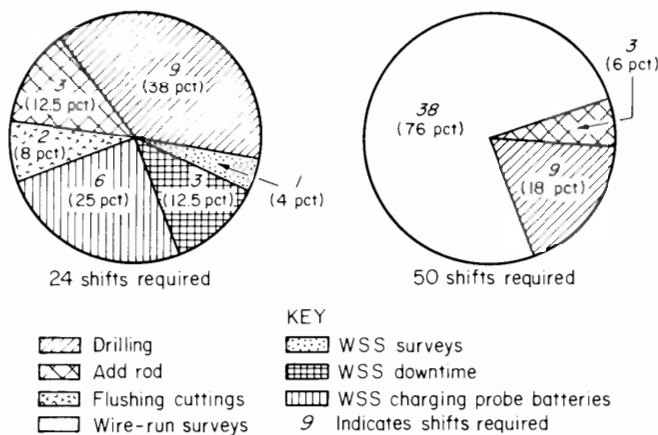

Figure 10.—Comparison of available drilling time with WSS (left) and wire-run survey instrument (right).

Raw data are transmitted, picked up by the uphole receiving transformer, accepted by the uphole receiver, processed by the uphole processor, and displayed. If the calculated data does not make any sense, it is usually considered bad data. For example, reasonable changes between a 10-ft survey interval, might be $\pm 2^\circ$ in azimuth and $\pm 1^\circ$ in inclination, depending on the bent housing used on the downhole motor and its set orientation. If changes greater than expected occur, e.g., $\pm 4^\circ$ occur in azimuth or inclination, the data are suspect or bad. Furthermore, in the processor menus, which are described in the appendix, raw data and system status can be observed to determine the integrity of the raw data transmitted including sensor outputs, the downhole guidance probe's analog to digital (A-D) reference voltage, the downhole guidance probe's battery voltages, etc. This information indicates whether

the data transmitted were bad and whether a survey should be tried again or if maintenance is required. When no data are transmitted, the uphole receiver indicates that it never received a transmission. If the downhole guidance probe and uphole system are assumed to be operational, and batteries sufficiently charged, conditions in the borehole prevented the downhole guidance probe from sending a signal that the uphole receiver could recognize or pickup.

Flushing cuttings from the borehole from depths greater than 2,300 ft became very difficult, several times taking as long as 30 min. A total decrease in elevation of about 7 ft from the beginning of the borehole to 2,300 ft could have contributed to the difficulty flushing cuttings. Also, approximately six large clay veins were intercepted from 2,300 ft to borehole completion. Because clay veins are relatively conductive, the signal current could have been coupled from the drill string to the clay veins, contributing to the number of unsuccessful surveys experienced. A summary of WSS surveys attempted from 2,300 ft to borehole completion follows.

At a borehole depth of 2,298 ft, the downhole guidance probe was installed in the borehole for the last time after recharging the batteries. A total of 307 surveys had been attempted surveying to this depth, 82 pct (253) of which were successful while 18 pct (54) were not. Of the 54 unsuccessful transmissions, bad data were transmitted 52 times with no data being transmitted twice. From 2,279 to 2,519 ft survey depth, 42 surveys were attempted, of which 21 (50 pct) were successful and 21 were not. No data were transmitted 18 of the 21 unsuccessful surveys while drilling from 2,399 to 2,479 ft. The WSS did transmit survey data from depths of 2,479 to 2,519 ft. WSS surveys were attempted from 2,519 to 2,608 ft, but were unsuccessful because the downhole guidance probe had been in the borehole for 5.5 days and needed to be recharged.

CONCLUSIONS

The preproduction Wireless Survey System (WSS) provided the borehole survey data, on a near real-time basis, necessary to navigate a 2,538 ft directionally drilled horizontal methane drainage borehole drilled in the Pittsburgh Coalbed. WSS surveys were conducted on 10 ft drilling intervals, taking less than 1 min for each survey transmission, regardless of borehole depth. The WSS operated reliably to a borehole depth of 2,300 ft with 82 pct of the surveys attempted successful. From 2,300 ft to borehole completion, only 50 pct of the WSS surveys attempted were successful. Difficulty in adequately flushing the drill cuttings from the borehole and the interception of several clay veins is believed to have caused or contributed to short circuiting of the signal current.

By considering available drilling time, which does not include hydraulic drill downtime or the time spent

traveling portal to portal, 24, 8-h shifts were needed to complete the 2,538 ft borehole. Fifty percent of the available drilling time was spent drilling and 50 pct surveying. Of the 50 pct surveying time, 4 pct was occupied transmitting survey data, 13 pct WSS downtime, 25 pct charging the downhole guidance probe's batteries, and 8 pct additional time required to ensure adequate flushing of cuttings from the borehole. By comparison, using a commercially available, wire-run permissible directional survey tool would have taken 217 pct more surveying time to complete the 2,538 ft borehole surveying at 10 ft drilling intervals. Consequently, drilling efficiency was increased 108 pct because of the WSS, in comparison with using the wire-run directional survey tool.

REFERENCES

1. Hagood, D. W., R. C. Pate, and J. W. Stevenson. Methane Control in an Advancing Section of an Underground Coal Mine (contract S0395033, Jim Walters Resourc., Inc.). BuMines OFR 94-84, 1983, 39 pp.; NTIS: PB 84-185057.
2. Finfinger, G. L., and J. Cervik. Review of Horizontal Drilling Technology for Methane Drainage From U.S. Coalbeds. BuMines IC 8829, 1980, 20 pp.
3. Deul, M., and J. Cervik. Methane Drainage in the Pittsburgh Coalbed. Paper in XVII International Conference of Mining Safety Research (Varna, Bulgaria, Oct. 3-7, 1977), pp. 9-15.
4. Cervik, J., H. H. Fields, and G. N. Aul. Rotary Drilling Holes in Coalbeds for Degasification. BuMines RI 8097, 1975, 21 pp.
5. Prosser, L. J., Jr., G. L. Finfinger, and J. Cervik. Methane Draining Study Using an Underground Pipeline, Marianna Mine 58. BuMines RI 8577, 1981, 29 pp.
6. Kravits, S. J., A. Sainato, and G. L. Finfinger. Comparison of Rotary and In-Hole Motor Techniques for Drilling Horizontal Boreholes in Coal. BuMines RI 8933, 1985, 33 pp.
7. Pittard, F. 2-7/8 Inch High-Torque Slimdril Motor Performance Data. Slimdril, Inc., Houston, TX, 1984, 21 pp.
8. Kravits, S. J., A. Sainato, and G. L. Finfinger. Accurate Directional Borehole Drilling: A Case Study at Navajo Dam, New Mexico. BuMines RI 9102, 1987, 25 pp.
9. Sammarco, J. J. Intrinsically Safe 5-V, 4-A Rechargeable Power Supply. BuMines IC 9223, 1989, 11 pp.
10. Marsh, J. L. Hand-Held Calculator Assists in Directional Drilling Control, Part 2 - Calculating Borehole Sensor Outputs. Pct. Eng. Int., July 1982, pp. 79-88.

APPENDIX.—ELECTRONIC DESIGN, MECHANICAL DESIGN, OPERATION OF WIRELESS SURVEY SYSTEM, AND RECOMMENDATIONS

The following appendix explains in detail the WSS's electronic design, mechanical design, operation, and recommends design modifications for a production model WSS. The Mine Safety and Health Administration (MSHA) granted the Bureau Experimental Permit No. EP-569-0 for use of the WSS by the Bureau in BethEnergy Mines, Inc., Mine No. 60. The downhole guidance probe was evaluated as explosion proof and the uphole receiving transformer and uphole receiver processor intrinsically safe.

WIRELESS SURVEY SYSTEM DOWNHOLE GUIDANCE PROBE

The WSS's downhole guidance probe is positioned directly behind the downhole motor as shown by figures 4 and A-1. The downhole guidance probe consists of sensors, electronics, batteries, and transmitter. Figure A-2 is a block diagram of the downhole guidance probe.

Downhole Guidance Probe's Sensors

The Develco MWD (Measurement While Drilling) Sensor, Model 106470, was selected as the sensor package for the WSS's downhole guidance probe because of its off-the-shelf availability, inherently precise alignment, and

small size of 1.5-in-OD by 24.5 in. in length (figs. 2 and A-3). The Develco sensor package comprises three single axis flux gate magnetometers, three single axis servo accelerometers, and a temperature sensor. Within the sensor package, the axis of each magnetometer and accelerometer are precisely aligned to be mutually orthogonal to each other. Consequently, when the sensor package is placed within its aluminum canister and assembled in the copper beryllium outer collar (assembly and mechanical design of the downhole guidance probe are discussed later), one magnetometer and accelerometer are aligned with the axial direction of the probe and two magnetometers and accelerometers are aligned radially.

The Develco sensor package is used to accurately measure the orientation of the downhole guidance probe with respect to the Earth's magnetic and gravitational field vectors. In addition to the three magnetometers and accelerometers, the Develco package is equipped with a temperature sensor. When surveying deep vertical wells drilled for oil and gas exploration or production, which is a more typical application of the Develco package, monitoring the temperature is essential so that sensor errors caused by extreme temperatures (100° C plus) can be corrected. Although the output of the temperature sensor is transmitted, extreme temperatures are not encountered when drilling horizontal methane drainage borcholes in coal. The manufacturer specifications of the Develco sensor package are provided in table A-1.

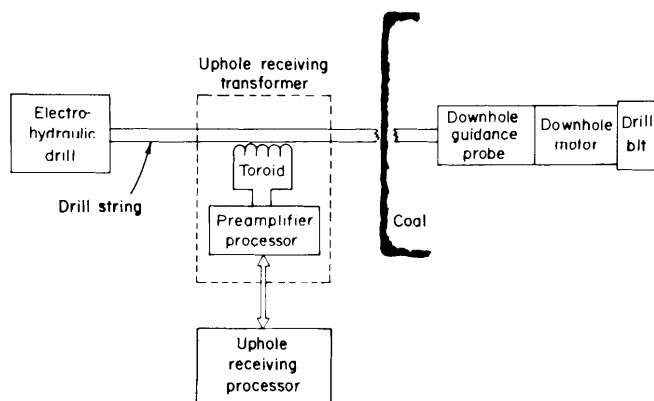

Figure A-1.—WSS block diagram.

Table A-1.—Specifications of Develco Model 106470 sensor package

Each axis magnetometer:

Output: 5 V/G (Earth's field typically 0.7 G)
 Alignment: $\pm 0.2^\circ$
 Offset: ± 0.003 G
 Linearity: ± 0.2 pct full scale

Each axis accelerometer:

Output: ± 4.5 V/G (Earth's field typically 1 G)
 Alignment: $\pm 0.2^\circ$
 Offset: ± 0.003 G
 Linearity: ± 0.1 pct

Power: 20-30 V dc at 100 mA (max)

Dimensions: 24.5 in. in length by 1.5-in-OD

Weight: 4 lb

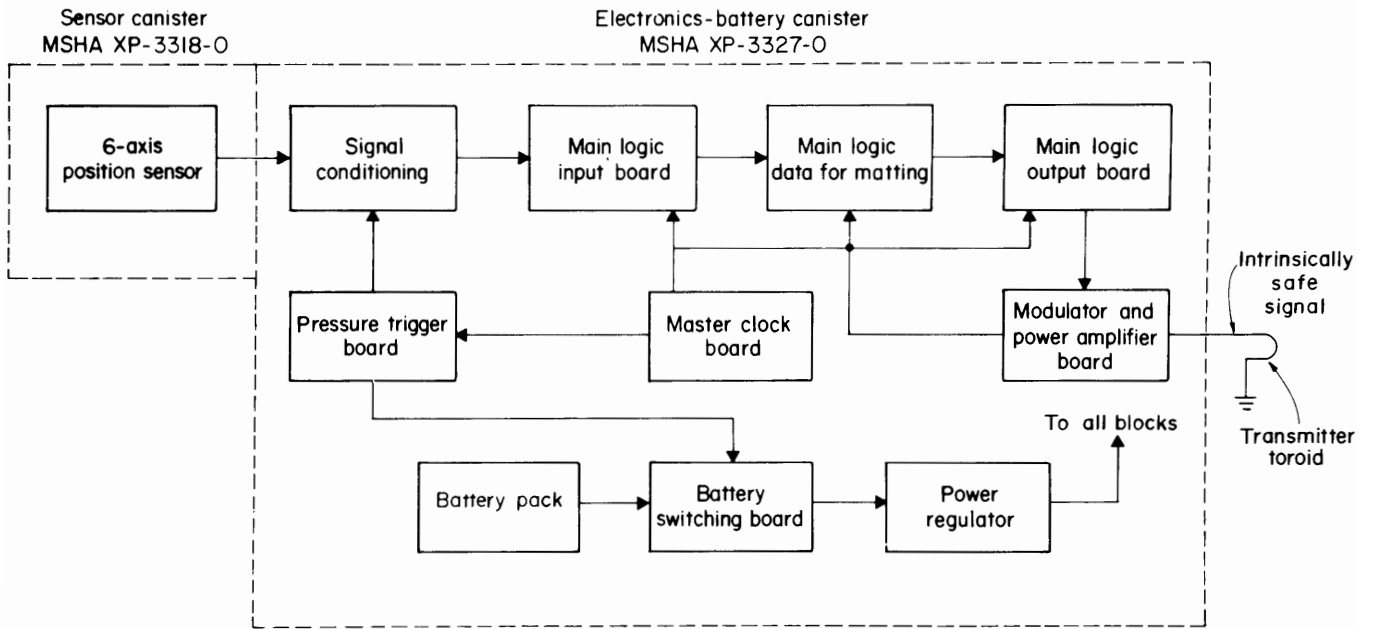

Figure A-2.-Downhole guidance probe block diagram.

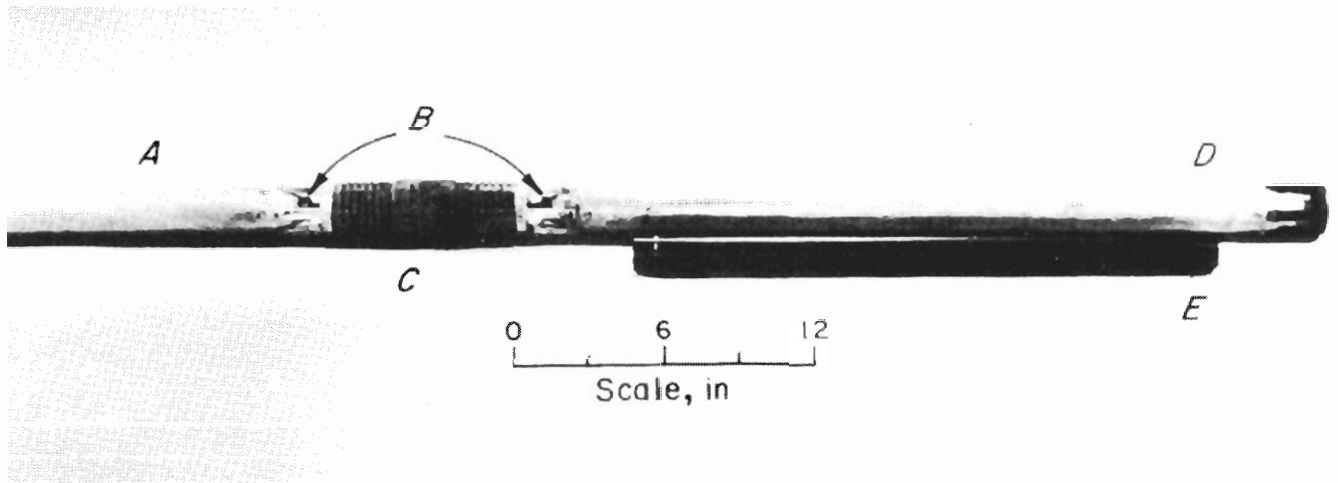

Figure A-3.-Sensor package and canister. A, Electronics; B, 3/16-in-OD steel conduit; C, sensor-electronics transition piece; D, sensor canister; E, sensor.

The Develco sensor package is mounted inside an aluminum canister evaluated and certified by MSHA, as explosion proof, XP-3318-0 (figs. 2 and A-3). The sensor wires are fed through a steel 0.19-in-ID conduit that is fastened to the second explosion-proof canister containing the signal processing and transmission circuitry (fig. A-4). This second explosion-proof canister, MSHA XP-3327-0, is the electronics-battery canister.

Downhole Guidance Probe's Electronics

Referring to figure A-2, the first block that will be discussed is the battery switching circuits. These circuits are used to switch downhole battery power on to all circuits during a survey-transmission cycle as dictated by the pressure trigger printed circuit board (the downhole batteries will be discussed later). In addition, the battery switching printed circuit board contains two very low power, voltage regulators, that provide full-time ± 12 V regulated power to the master clock and the pressure trigger printed circuit boards.

To explain the functions of the remaining circuitry in the downhole electronics, a survey-transmission cycle will be discussed starting with the master clock board. The majority of the master clock board's circuits operate full time containing the master clock for the entire system. The master clock contains a crystal controlled oscillator operating at 4.0 MHz that is counted by a low-power complementary metal oxide silicon (CMOS) counter to form the various frequencies needed to operate the system. One output is used to command the pressure trigger circuit to take a sample of the drilling water pressure every 8.4 s. The remainder of the master clock outputs are disabled until a survey is initiated.

The pressure trigger circuitry consists of a strain gauge pressure transducer, signal conditioning circuits, and a peak detection and threshold comparator. The pressure transducer has a measurement range of 0-1,000 psi that is converted by the signal conditioning circuits calibrated to produce 5 V at 1,000 psi. Every 8.4 s the transducer bridge, signal conditioner, and peak detector are activated for 100 ms to measure and store the current value of the drilling water pressure. Whenever the current value is less than 10 pct of the peak stored value, a signal is generated to trigger or activate power to the entire downhole guidance probe including measuring and transmitting the position of the probe uphole via the drill string. This design was based on the assumption that after drilling a 10-ft drill rod, the water pumps supplying drilling water are shut off to add another drill rod. After a survey has been completed taking about 1 min, a drill rod is added and drilling is resumed. The stored value in the peak detector is reset to zero at the completion of each survey to begin a new search cycle for peak and 10 pct of peak pressure. The pressure trigger circuitry and the downhole guidance probe remain inactive until pressure is applied and released.

Upon activation, power and the master clock are applied to the remaining circuitry in the downhole electronics. The Develco sensor outputs are digitized by a 12-bit A-D converter and stored serially in a 256-bit long shift register. The data that are digitized comes from the signal conditioning printed circuit board comprised of several analog operational amplifiers that amplify and filter the 11 data channels to the proper scale factors. Table A-2 indicates downhole guidance probe channel assignment while table A-3 describes proper A-D converter analog to digital scale factors.

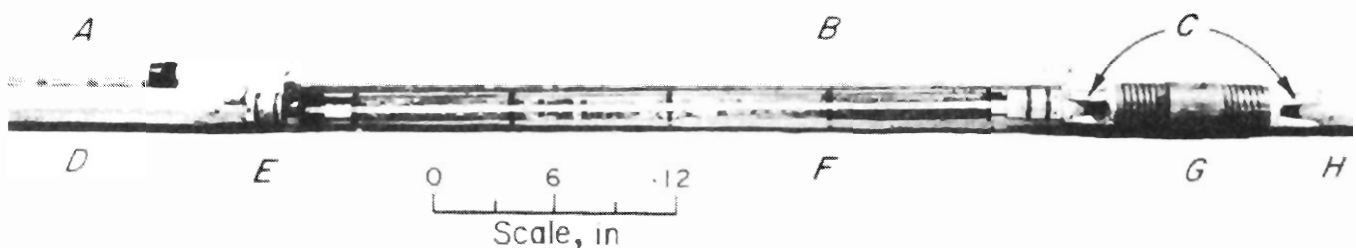

Figure A-4.—Signal processing and transmission circuitry. A, Batteries; B, electronics canister; C, steel conduit for sensor wires; D, battery canister; E, battery end plug with O-rings; F, electronics; G, sensor-electronics transition piece; H, sensors.

Table A-2.-Downhole guidance probe channel assignment

Channel ¹	Assignment
1	Magnetometer X axis, ±1.0 G ±5 V.
2	Magnetometer Y axis, ±1.0 G ±5 V.
3	Magnetometer Z axis, ±1.0 G ±5 V.
4	Accelerometer single axis, Z axis lg = ±4.5 V.
5	Accelerometer biaxial X axis lg = ±4.5 V.
6	Accelerometer biaxial Y axis lg = ±4.5 V.
7	Temperature, 0° to 50° C = 0 to 5 V.
8	Reference voltage, +2.500 V, for A-D converter.
9	Negative battery voltage monitor, -2.25 V nominal.
10	Positive battery voltage monitor, +2.25 V nominal.
11	Peak pressure drilling fluid, 5 V per 1,000 psi.

¹Channels 12 through 16 not used.

Table A-3.-A-D converter scaling factors

Bit	Scaling factor
¹ 1 2 3 4 5 6 7 8 9 10 11 ² 12	
0 0 0 0 0 0 0 0 0 0 0 0	Plus full scale, plus 5.0 V.
0 0 0 0 0 0 0 0 0 0 0 1	Plus full scale, minus 1 count, minus 4.9976 V.
0 1 1 1 1 1 1 1 1 1 1 1	Plus 1 count, plus 0.0024 V.
1 0 0 0 0 0 0 0 0 0 0 0	Zero.
1 0 0 0 0 0 0 0 0 0 0 1	Minus 1 count, minus 0.0024 V.
1 1 1 1 1 1 1 1 1 1 1 0	Minus full scale, plus 1 count, minus 4.0076 V.
1 1 1 1 1 1 1 1 1 1 1 1	Minus full scale, minus 4.9976 V.

¹Most significant bit.

²Least significant bit.

While data are being transmitted, the power amplifier is being fed with a 5.028 kHz carrier designated as the 0° carrier. This carrier operates for 16.4 s allowing time for the uphole receiver to perform automatic gain range and phase lock functions on the stable carrier. Immediately after the 16.4 s, the logic switches to all binary ones data modulation for 4.2 s so that the uphole receiver can establish a phase lock on the 40.6875 Hz data clock. After the 4.2 s of all ones have been transmitted, a 32-bit preamble is sent. The 32-bit code is hardwired into the uphole receiver and is continuously monitored for bit pattern match. Once match is found, the receiver will open its data and clock lines to the uphole processor and begin handing the received data to the processor. Three bits of random data, not used, followed by 143 bits (11, 12-bit channels plus 1-bit parity per channel) are then sent to the processor. The following is the transmission sequence:

1. Upon activating the downhole guidance probe, the probe transmits 16.8 s of 0° phase shift carrier (no modulation) used by the uphole receiver to establish carrier phase lock and auto gain range.

2. The carrier is followed with 4.2 s of all one's data used by the uphole receiver to establish data clock and phase lock.

3. All one's data are followed by the 32-bit preamble used by the uphole receiver to acknowledge that the upcoming data are real to prepare to alert the uphole processor.

4. The preamble code is
10110000110111001011000011011100.

5. If the exact code is not recognized, the uphole receiver will ignore the remainder of the transmission.

6. The next three bits of data transmitted are sent to the uphole processor, but are thrown away as meaningless.

7. The last 208 bits are transmitted and received by the uphole receiver representing 16 channels of 12-bit offset binary data plus one parity bit per channel. Only 11 channels of data, 143 bits, are used by the processor.

As stated earlier the output of the power amplifier is coupled to the drill string by the downhole transmitter through which an electric current is induced (fig. 2 and fig. A-5 and table A-4). Once all the data has been transmitted to the uphole receiver, the downhole guidance probe signals itself to shutdown and returns to the dormant status.

Table A-4.-Power amplifier and downhole guidance probe output

Carrier frequency . . .	5.2028 kHz ±0.005 pct crystal controlled.
Modulation	4 W nominal to input of downhole transmitter, varies with coupling conditions. Also note that the output signal of the downhole transmitter was evaluated as intrinsically safe by MSHA.

Downhole Guidance Probe's Batteries

The battery pack original design, consisted of 14 X cells of a sealed lead acid-starved electrolyte battery manufactured by Gates Energy, Denver, CO (figs. A-6-A-7). The cells each have a nominal capacity of 5 A·h with a cell voltage of 2 V. The 14 cells were daisy chained together to provide ±14 V to the downhole electronics. Flat printed ribbon tape was used to interconnect the daisy chain of 14 cells before installing them into the explosion-proof battery canister. The life of the battery pack using X cells was expected to be adequate enough to drill a 2,000-ft horizontal methane drainage borehole without requiring recharge. Recharging the battery pack is an operation that would require retrieval of the downhole guidance probe from the borehole, removal of the downhole guidance probe's outer beryllium collar, and transporting the downhole guidance probe to the fresh air environment to charge the downhole batteries as required by MSHA.

Unfortunately, the battery packs original design did not prove to be reliable. During lab testing and calibration at the surface, the flat ribbon tape connecting the X cell batteries failed several times.

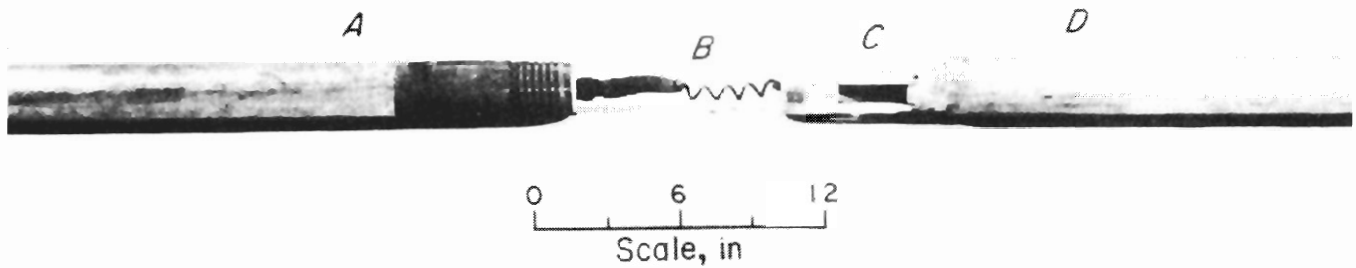

Figure A-5.—Current inducing transmitter. A, Transmitter; B, battery-transmitter cable; C, battery pack; D, outer copper beryllium collar.

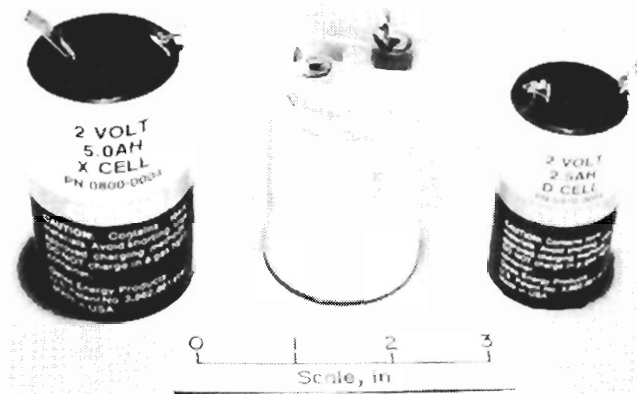

Figure A-6.—Sealed lead acid batteries. X cell (left), X cell without outer case (center), D cell (right).

The outer case of each battery had already been removed (fig. A-6), while the inner diameter of the battery canister could not be increased because reducing the wall thickness would have prevented the canister from being explosion proof. Considering the critical timing of the problem, it was decided to replace the X cells with smaller D size sealed lead acid batteries, 2.5 A·h, 2.1 V, interconnected with larger diameter conventional wire. Obviously, the trade-off using the smaller 2.5 A·h batteries would result in one-half less surveying time or life in the borehole because the downhole guidance probe would need to be pulled from the borehole twice as often to recharge the batteries.

The calculation for determining the battery capacity needed was based on several factors and assumptions. First, there is a continuous current drain of approximately

13 mA to power the pressure sensing and command logic circuitry or 0.3125 A·h/d. Second, the current draw during an actual survey and data transmission is approximately 1 A.

Each 1 A transmission consumes 7.5 mA·h based on the calculation of 27 s per transmission divided by 3,600 s/h multiplied by 1 A. Assuming that during a typical drilling shift 200 ft would be drilled resulting in conducting 25 surveys including 5 unsuccessful transmissions. Survey current draw would then consume 0.1875 A·h/d. Therefore, considering standby and survey current draw, 0.49 A·h would be consumed per day, which would require recharging the downhole guidance probe batteries about every 5 days.

Assembly of the Downhole Guidance Probe

The downhole guidance probe's sensors, electronics, and batteries are contained within or housed by explosion-proof, aluminum, 2-in-OD canisters (figs. A-3-A-4). The sensor and electronics canisters are joined by a copper beryllium transition piece while the electronics and batteries are joined by an aluminum gland with O-rings. The battery pack must be installed into the electronics in fresh air. The total assembled length of the sensor and electronics-battery canisters is about 11 ft with an approximate weight of 40 lb. Once the inner canisters have been assembled, they can be carried to the drill site in preparation for final assembly of the downhole transmitter and the outer copper beryllium collars. Final assembly begins by installing the section of the copper beryllium collar, 2.62-in-OD, 2.25-in-ID, 6.6 ft in length, over the sensor canister and threading it onto the copper beryllium transition piece using pipewrenches (fig. A-8). Keeping the transmitter cable tucked inside the delrin centralizer belonging to the battery package, the copper beryllium collar with the same diameter as the collar already used, but 9.6 ft in length, is fit over the electronics-battery canister and threaded onto

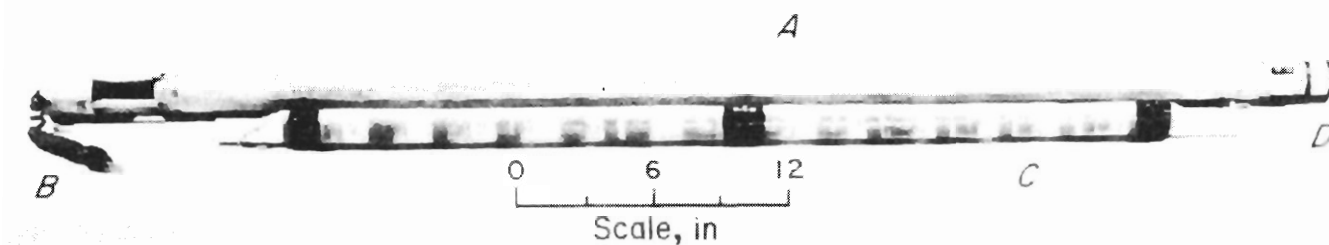

Figure A-7.—Battery pack. A, Battery canister; B, battery-transmitter cable; C, D cell battery string; D, battery pack and plug.

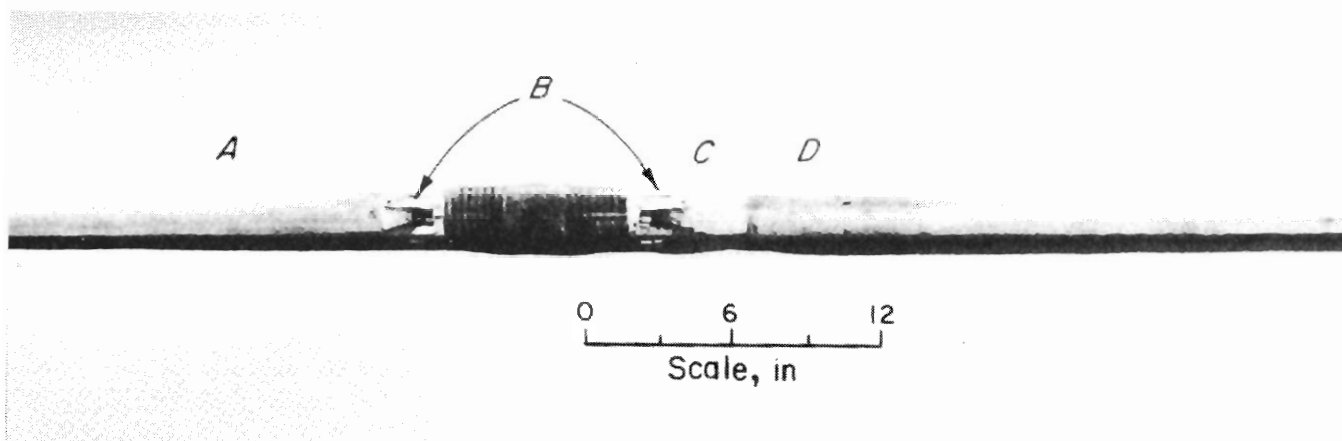

Figure A-8.—Sensor canister and outer collar. A, Battery canister; B, steel conduit; C, sensor canister; D, outer collar.

the electronics sensor transition piece (fig. A-4). Finally, the transmitter cable is threaded into the downhole transmitter, followed by threading the transmitter into the outer collar. Assembling the downhole guidance probe's outer collar over the sensor and electronics-battery canisters takes about 1 h.

Waterflow to the downhole motor and drill bit passes through the downhole transmitter to the 0.25-in annular space between the outer wall of the inner canisters and inner wall of the outer copper beryllium collar. The total weight of the assembled downhole guidance probe is about 200 lb with a length of 21 ft.

UPHOLE RECEIVING TRANSFORMER AND RECEIVER PROCESSOR

Uphole Receiving Transformer

The signal current transmitted by the downhole guidance probe induced onto the drill string is detected by the uphole receiving transformer (figs. 3, A-9, and A-10). In addition to the high sensitivity current toroidal transformer, the uphole receiving transformer contains a 30 dB gain preamp and high Q or very selective passive filter with a centering frequency of 5.208 kHz. The preamp gain can

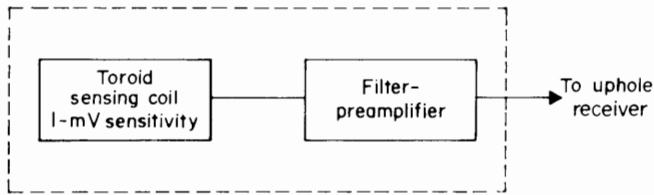

Figure A-9.—Uphole receiving transformer block diagram.

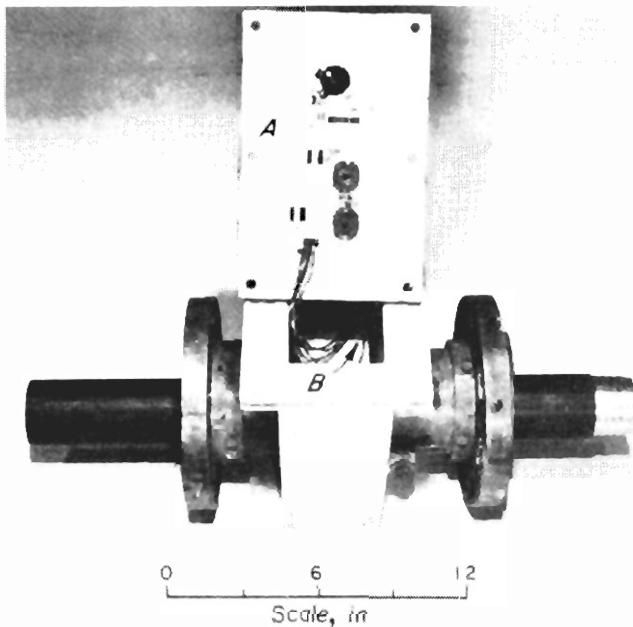

Figure A-10.—Uphole receiving transformer. A, Filter-preamp circuit board; B, current toroidal transformer.

be switched between 0 and 30 dB as needed by the automatic gain control circuitry of the uphole receiver to be discussed later.

The uphole receiving transformer is contained within a watertight aluminum housing fitted onto a 4-in-ID plastic polyvinyl chloride (PVC) pipe and flanges that are used to fasten it in-line with the gas handling equipment (fig. A-11).

Uphole Receiver

The final component of the WSS is the uphole receiver processor (figs. A-12-A-13). As indicated by figure A-13, there are five major blocks that make up the receiver processor.

The uphole receiver is comprised of an automatic gain amplifier section, phase lock loop, data demodulator, and

status register. The automatic gain amplifier consists of two stages of low noise operational amplifiers with multiplying digital to analog (D-A) converter elements connected in their feedback loop. The gain is adjusted by incrementing or decrementing an 8-bit digital register to increase or decrease the gain. The overflow or underflow of the register is used to select the gain, 30 dB or 0 dB, of the preamplifier in the uphole receiving transformer.

The output of the variable gain amplifier is fed to both the phase lock loop and demodulator. The purpose of the phase lock loop is to establish both a carrier and data clocks in precise phase relationship to the downhole guidance probe. These clocks are used to demodulate the $\pm 60^\circ$ phase modulated carrier. Manchester coding is used with the $\pm 60^\circ$ phase modulation because it offers one of the best immunities to interference from noise. Manchester coding has additional requirements compared with standard non return to zero (NRZ) coding whereby the direction of a transition as well as the transition itself be decoded to determine presence of a one or zero.

When the uphole receiver detects a valid 32-bit preamble code, it makes a serial data string and data clock available to the processor. Unlike the downhole guidance probe, which transmits 208-bit data string from 16 channels, of data, the receiver cuts the string short at the end of the 11 channel. At that point, the contents of an internal 12-bit receiver status register are handed to the processor. The data contained in this register include the values of the 8-bit gain register, the overflow underflow status of the gain register, and bit to warn if the +8 V receiver battery is nearing the end of its capacity.

All of the electronic components of the uphole receiver are CMOS technology to take advantage of its good noise immunity and low power consumption.

Uphole Processor

An Intel ISBC 80/24 single board computer was used as the WSS uphole processor (figs. A-13-A-14). All software was written using program language machine (PLM) language primarily to expedite the construction of a system with in-house technology and development system. Initially, a CMOS version, off-the-shelf processor was planned to be used to reduce the power requirements. However, a CMOS version processor or equivalent was not off-the-shelf available and operational in time for the project. This created problems with respect to the required battery levels to power the transistor transistor logic (TTL) version processor maintaining intrinsic safety. A permissible high-current +8 V battery pack was developed solely for the processor printed circuit board containing active integrated circuitry that would limit power levels in the event of fault conditions (9).¹

¹Italic numbers in parentheses refer to items in the list of references preceding the appendix.

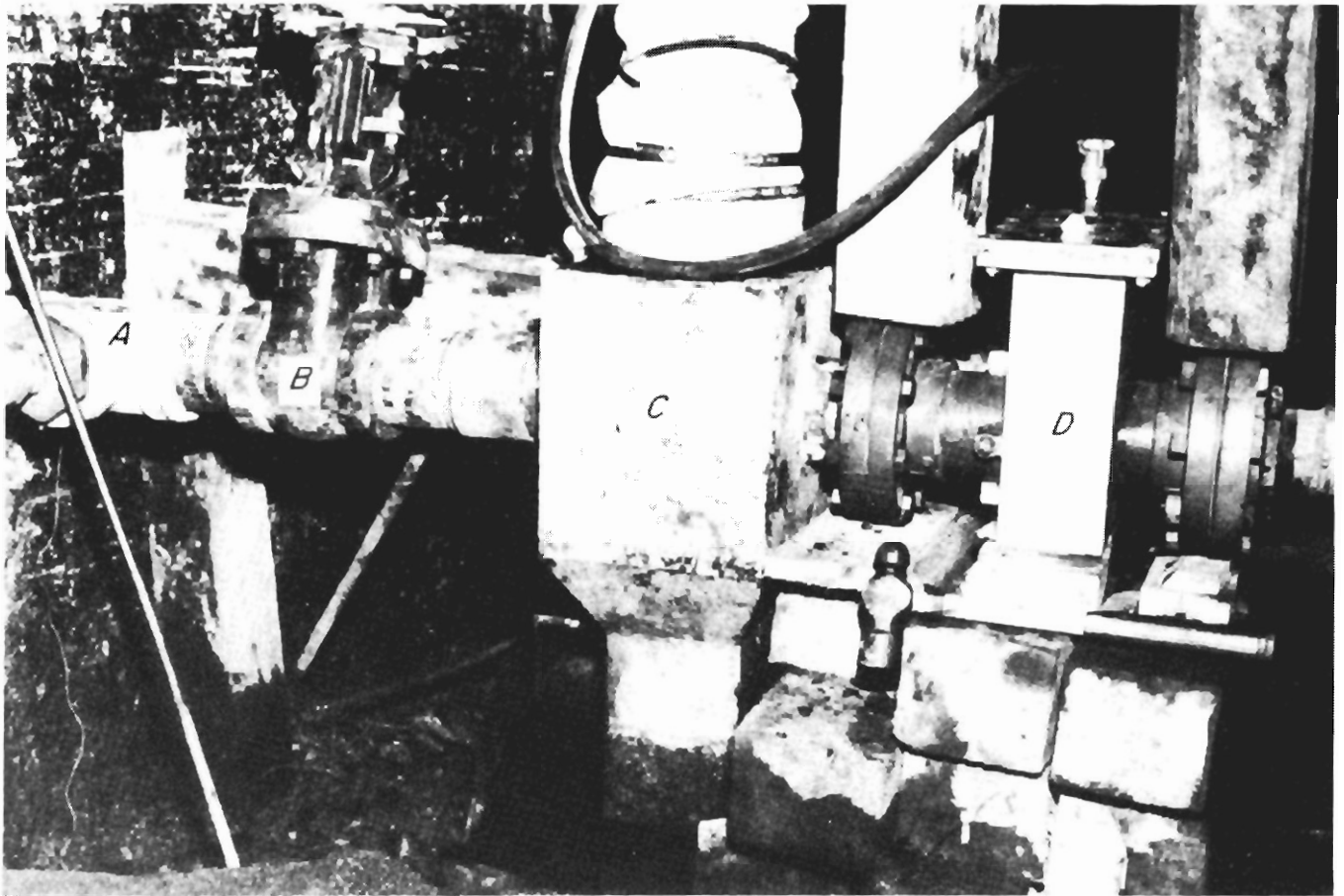

Figure A-11.—Uphole receiving transformer and gas handling equipment. A, Collar or standpipe; B, manual shut-in valve; C, gas-water separator; D, uphole receiving transformer.

As stated earlier, due to time constraints, the software was implemented in the PLM language. Under this system, many subroutines for specific tasks already existed in the PLM library and could be easily used. The disadvantage of this software method with respect to an operational production system is the amount of memory overhead required to contain the PLM library.

The algorithms used to process the raw survey data into positional information were essentially the same as those provided by Develco (10). One change was made in the calculation of inclination. Because the WSS was designed primarily to survey horizontal methane drainage boreholes, only the Z-axis accelerometer output was used to calculate inclination. The equation used was $\phi = \sin^{-1}(V/G)$ where ϕ is the angle of inclination with 0° as horizontal, V is the voltage of the Z-axis accelerometer, and G is full-scale voltage for 1 G acceleration. This method was chosen over using the outputs of the X- and Y-accelerometers to eliminate the error of two sensors by only having the error of one. Also as suggested by Marsh (10), in order to eliminate the errors due to different absolute values of the Earth's magnetic and gravitational fields from one location

to another, all data signals were normalized to a full-scale value of 1. Therefore, all equations work only on values of 0 to 1.

Once the processor calculates all values for the survey depth, including inclination, azimuth, and orientation of the bent housing, it stores the data in a small portable Termiflex HT 1000 terminal, which is a stock item. To make it intrinsically safe (evaluated as part of the processor), the lithium inorganic thionyl chloride battery was replaced with a lithium solid electrolyte, 2.4 V Saft battery.

The Termiflex is used as a system control device, menu driven, in addition to storing and displaying data. Three menus are available including: (1) raw data, (2) calculated data, i.e., inclination, azimuth, and orientation of downhole motor's bent housing, and (3) control. The first menu provides all 11 channels of raw data as indicated by table A-2. Calculated data are made available through menu two. Inclination, azimuth, and survey depth were entered into a Hewlett Packard 15C calculator programmed with a radius of curvature program to determine borehole coordinates and elevation. Menu three is a control menu consisting of: message entering capability, system status

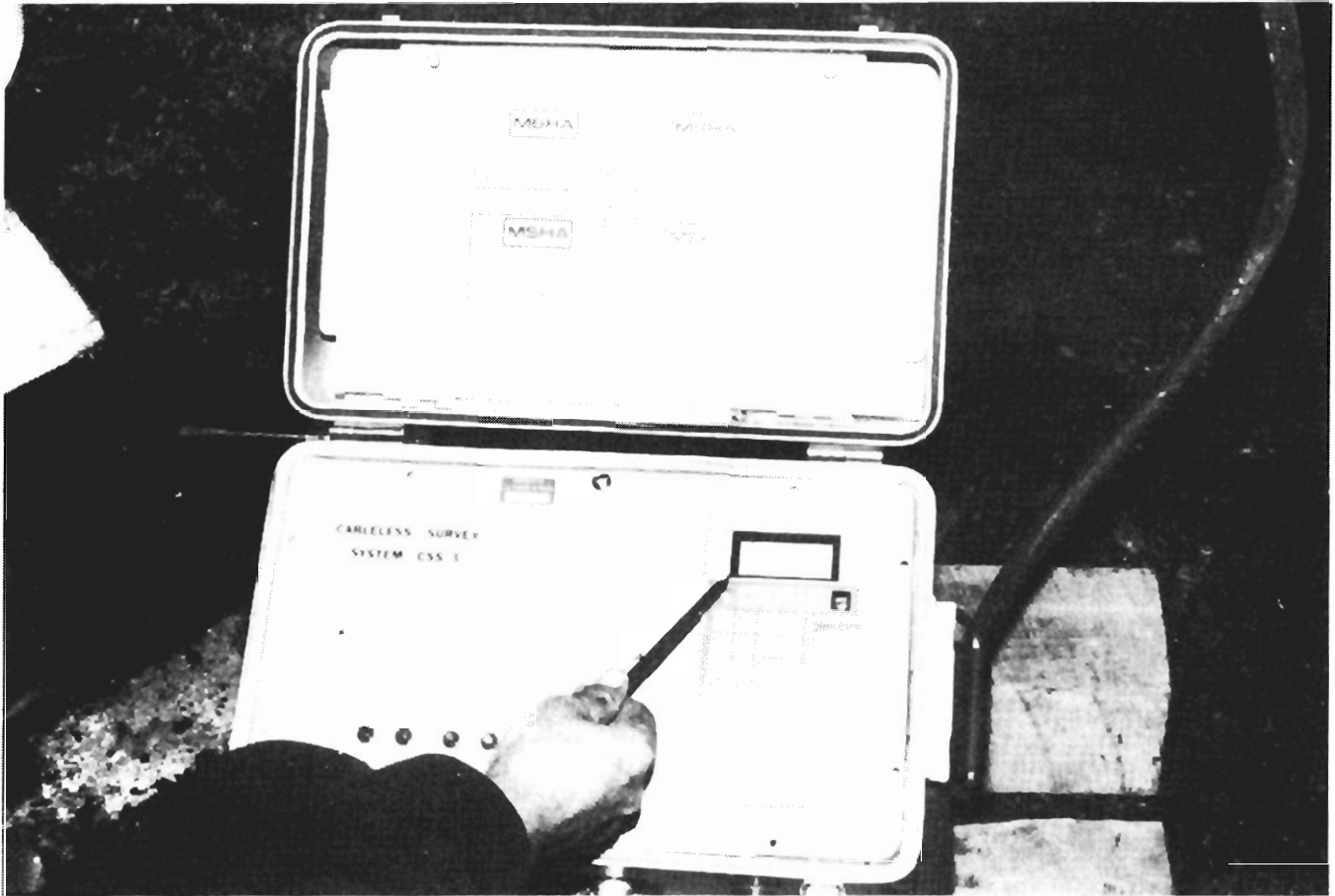

Figure A-12.-Uphole receiver processor showing operating display and MSHA experimental permit labels.

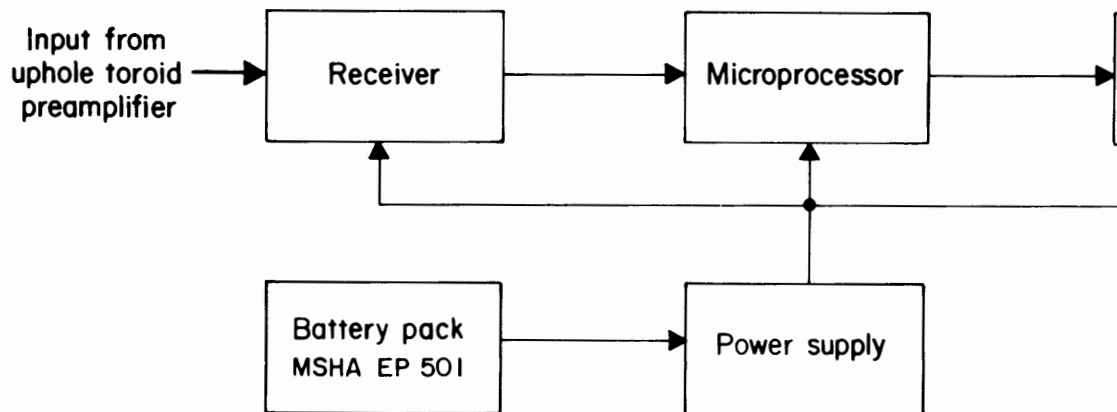

Figure A-13.-Uphole receiver processor block diagram.

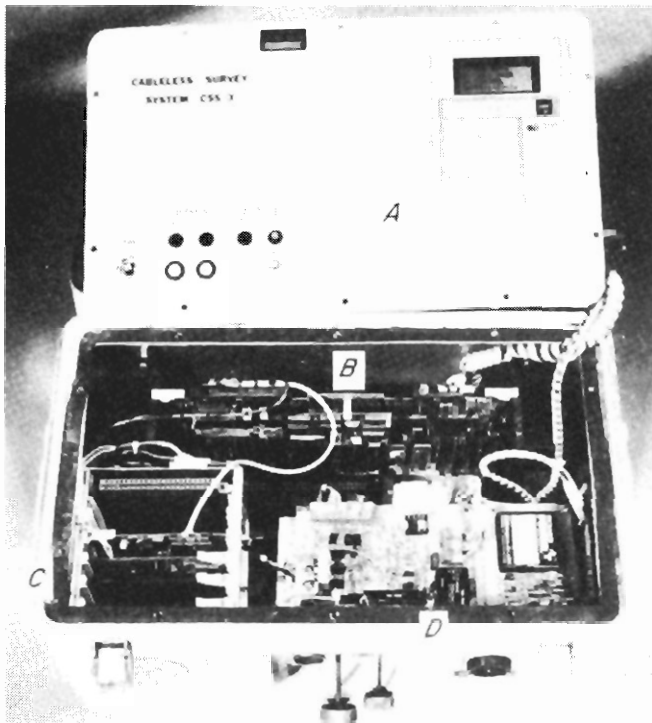

Figure A-14.—Uphole receiver processor. A, Display; B, processor board; C, receiver; D, power supply board.

providing uphole receiver gain, a monitor of the number of set floating bits, capability of entering a new number set of floating bits, and warning for low receiver batteries.

RECOMMENDATIONS

The preproduction WSS performed reliably during the in-mine test. However, the preproduction WSS would be in need of considerable modifications in electronic and mechanical design primarily in the downhole guidance probe, if it were made into a production model.

In order to reduce the amount of discrete circuitry and the space it occupies, new advances in large-scale integration circuits (LSI) could be utilized. Off-the-shelf, small low-power LSI circuits could be used to replace the function of 10 to 15 circuits with a single package that would occupy the space of two or three of the existing circuits. For example, the use of a 80C85 CMOS processor would perform the entire control and sequencing functions currently done discretely. This family of microprocessors has

units that contain times, registers, small amounts of random access memory (RAM), and a processor, all in one device.

Increases in reliability and space reductions could also be realized by using one of the new complete analog to digital data acquisition models to replace the entire data gathering, conditioning and digital conversion portion of the circuitry. Units such as the BurrBrown SDM857 are completely self-contained data acquisition units. When microprocessor controlled, the unit can do scaling and gain ranging allowing each analog sensor to be scaled and adjusted prior to digitizing.

Recent advances in digital data transmission used by the telecommunications industry has also brought forth numerous LSI circuits that cannot only reduce circuitry in the downhole guidance probe, but also in the uphole receiver. These new devices would permit the application of new technologies that offer excellent immunity to noise interference. Use of the devices would reduce the number of components resulting in size reductions and increases in reliability, and because they are off-the-shelf components less customizing of both hardware and software to acquire and process the data would be required.

The most significant problem with the preproduction WSS was not having adequate battery power to keep the downhole guidance probe in the borehole until completion. A solution to this problem would be to install a small rare earth magnet alternator and small turbine to drive the alternator to keep the batteries fully charged. While drilling, waterflow to the downhole motor and drill bit would turn the turbine powering the alternator, which in turn would keep the batteries charged. These turbines and alternators do exist for 6-in-ID equipment used in the MWD industry, for oil and gas exploration, and would need to be scaled down.

One other possible system improvement would be the addition of an uphole to downhole communication link. This link would only be used to activate the downhole guidance probe to conduct a survey. To integrate an uphole to downhole activation link, an uphole transmitter and coupling transducer to induce a signal into the drill string would be required. An additional transducer would not be required downhole because the existing transmitter would be used to receive the signal, only receive circuitry would be required.

In the uphole receiver, LSI CMOS circuitry could also be employed in the receiver demodulation. The processor should be replaced with a CMOS version to reduce power consumption. The software could be written in machine or assembly language to reduce the large memory overhead required with high-level languages, which would reduce the power requirements.