

**DEPARTMENT OF HEALTH AND HUMAN SERVICES**

**Public Health Service**

**42 CFR Part 84**

**RIN 0905-AB58**

**Respiratory Protective Devices**

**AGENCY:** National Institute for Occupational Safety and Health (NIOSH), Centers for Disease Control and Prevention, Public Health Service, HHS.

**ACTION:** Final rule.

**SUMMARY:** This final rule addresses NIOSH and the Department of Labor/Mine Safety and Health Administration (MSHA) certification requirements for respiratory protective devices. Specifically, the rule replaces MSHA regulations with new public health regulations, while also upgrading testing requirements for particulate filters.

This action is the first of a series of modules that will incrementally upgrade current respirator approval requirements. This modular approach will allow improvements to be implemented on a safety and health priority basis as well as facilitate adaptation to new requirements by the manufacturers and users of respirators. It will also expedite the incorporation of technological advancements and will allow for the expeditious response to emerging hazards.

Except for the particulate-filter requirements, most requirements of the existing regulations are incorporated

into the new regulations without change. The revised testing requirements for particulate filters significantly improve the effectiveness of evaluating air-purifying filters to remove toxic particulates from the ambient air. These requirements are consistent with two decades of advances in respiratory protection technology.

The certification of air-purifying respirators under the final rule will also enable respirator users to select from a broader range of certified respirators that meet the performance criteria recommended by CDC for respiratory devices used in health-care settings for protection against *Mycobacterium tuberculosis* (Mtb), the infectious agent that causes tuberculosis (TB).

Elsewhere in this separate part of the **Federal Register**, MSHA is publishing a final rule to remove existing regulations which are made obsolete by this final rule.

**EFFECTIVE DATES:** This final rule is effective on July 10, 1995. The incorporation by reference of certain publications used in the regulations is approved by the Director of the Federal Register as of July 10, 1995.

**FOR FURTHER INFORMATION CONTACT:** Richard W. Metzler, NIOSH, 1095 Willowdale Road, Morgantown, West Virginia 26505-2888. The telephone number is (304) 285-5907.

**SUPPLEMENTARY INFORMATION:**

**I. Availability of Copies and Access to Final Rule**

Additional copies of this final rule can be obtained by calling the NIOSH

toll-free information number (1-800-35-**NIOSH**, option 5, 9:00 AM-4:00 PM ET). Arrangements have also been made for this final rule to be listed on the electronic bulletin boards of the Government Printing Office and of the Department of Labor; the telephone numbers are (202) 512-1387 and (202) 219-4784, respectively. This final rule may also be obtained from the NIOSH Home Page on the World-Wide Web. The location for the NIOSH Home Page is <http://www.cdc.gov/niosh/homepage.html>.

**II. Paperwork Reduction Act**

This final rule contains information collections that have been approved by the Office of Management and Budget under the Paperwork Reduction Act of 1980 and assigned control Number 0920-0109. The title, description, and respondent description of the information collection are shown below with an estimate of the annual reporting and recordkeeping burden. Included in the estimate is the time for reviewing instructions, searching existing data sources, gathering and maintaining the data needed, and completing and reviewing the collection of information.

*Title:* Respiratory Protective Devices.

*Description:* This rule prescribes requirements and procedures which must be met in filing applications for approval by NIOSH of respirators and modifications of respirators.

*Description of Respondents:* Businesses and other for-profits.

*Estimated Annual Reporting and Recordkeeping Burden:*

Section	Annual number of respondents	Annual frequency	Average burden per response	Annual burden hours
84.35 .....	56	10.5	79.45 hr .....	46,716 hr.
84.41 .....	56	10.5	22.70 hr .....	13,347 hr.
84.43 .....	56	10.5	56.75 hr .....	33,369 hr.
Total .....	.....	.....	.....	130,805 hr.

The above citations are currently cleared under 30 CFR Part 11 as OMB control Number 0920-0109.

A Paperwork Reduction package is being submitted to OMB, requesting approval of the requirement for labeling to be effected by § 84.33. A document will be published in the **Federal Register** when such approval has been obtained.

**III. Background**

NIOSH published a proposed rule (59 FR 26850) to establish a new 42 CFR part 84, on May 24, 1994. On May 26, 1994, NIOSH published a notice in the

**Federal Register** (59 FR 27257) for an extension of the public comment period and a rescheduling of a public meeting. A public meeting was held to obtain comments on the proposal in Washington, D.C. on June 23-24, 1994.

The proposal and public meeting received response from the full complement of affected parties in the public. Commenters included safety professionals, respirator manufacturers, representatives of industrial and health-care facilities, and workers' associations. Three hundred and three commenters responded to the proposed

rule. One hundred twenty six commenters represented health-care workers. Ninety six commenters represented health-care facilities. Fifteen commenters represented associations of health-care professionals. Fifteen commenters represented associations of health-care facilities. Seventeen commenters represented respirator manufacturers. Eight commenters represented trade or manufacturers' associations. Eight individuals commented as private citizens. Six commenters represented regulatory agencies (federal, state,



county). Five commenters represented respiratory protection experts. Three commenters represented workers' organizations. Two commenters represented test instrument manufacturers. One commenter represented industrial hygiene professionals. One commenter represented a Federal Advisory Committee. These figures include the 18 presenters at the Public Meeting held in Washington, D.C. on June 23 and 24, 1994.

#### IV. Summary of Major Changes in Response to Comments

The requirements of the final rule differ from those proposed (59 FR 26850) in 8 major areas. These changes, discussed in sections V. Administrative and Procedural Matters of Final Rule and VI. Discussion of Final Rule, are summarized as follows:

1. Three categories (series) of particulate filters (N-, R-, and P-series) are included rather than two (solid and liquid and solid);
2. Maximum allowable inhalation and exhalation airflow resistance values have been slightly increased and labelling changes are included to identify the certified efficiency level to users;
3. The new certification categories apply only to non-powered air-purifying respirators. Powered air-purifying particulate respirators (PAPRs) will be approved only with filters meeting the requirements for 30 CFR part 11 high-efficiency filters;
4. A new subpart KK has been added for the issuance of extensions of existing 30 CFR part 11 approvals to address respirator non-conformances when there is a demonstrated safety or health need during the transition period and for the approval of PAPRs;
5. Fit testing during the certification process is not included for particulate respirators;
6. The number of tested units has been reduced and the test data will no longer be treated statistically;
7. The period for sale and shipment of 30 CFR part 11 certified particulate respirators has been increased. The period for processing part 11 applications has been eliminated, except for demonstrated need; and
8. Testing parameters are stated more explicitly.

A summary listing of the section-by-section changes from the proposal to this final rule is provided in Appendix A—Comparison of Technical Requirements Final Rule to Proposed Rule. Each of these changes is discussed in detail in the following preamble.

#### V. Administrative and Procedural Matters of Final Rule

##### A. Modular Approach

The proposed rule explained the intent to promulgate modifications to the requirements of 30 CFR part 11 in a series of modules. There are numerous benefits to utilizing a modular approach to promulgate changes to the existing requirements. Among these are the following considerations:

1. Improvements can be implemented on a priority basis, assuring that those expected to contribute most to improving worker protection are implemented first;

2. Incremental promulgation of improvements should facilitate adaptation to new requirements by the respirator manufacturer and user communities, minimizing the potential for any disruption in the supply of certified respirators;

3. Public participation in the rulemaking process will be facilitated by proposing important regulatory changes in individual segments of separate rulemaking; and

4. Improvements made to limited segments of the rule can be implemented in a much shorter time period than comprehensive revisions to the entire rule. Therefore implementation of technological advancements and response to emerging hazards will be expedited.

Comments overwhelmingly endorsed the concept of the modular approach with only two comments specifically opposed to this approach. More than 250 comments supported the proposal's approach and approximately 40 specifically endorsed and offered recommendations for changes in the modular scheduling. Some commenters expressed concerns about this new rulemaking procedure. These predominantly questioned the interaction of modules and implementation schedules. Module interaction concerns included added costs, confusion, transition periods (grandfathering) of interrelated modules, and redesign of respirators due to effects of multiple modules. Concerns of scheduling included the priority of modules, additional module topics, transition periods for products to meet prior requirements, timetable for completion of revisions, and availability of NIOSH resources to support work on multiple modules simultaneously.

The modular approach represents a continuous improvement strategy for rulemaking. With this process, NIOSH expects regulations and products to be incrementally improved and updated to address worker health concerns and

prevent any disruption in the supply of respirators. Each module will constitute a separate rulemaking activity. The modular approach undertaken by NIOSH provides clear advantages over the comprehensive approach to rulemaking. No specific time period has been identified in which all certification standards will be revised. The Institute recognizes that a predetermined revision cycle could ensure the periodic re-examination of standards. However, a requirement of this type would also diminish the capability of the Institute, with its limited resources, to address priority respiratory protection needs. The Institute has determined that a flexible approach is required that will permit expeditious responses to emerging respiratory protection priorities. These can change rapidly as technological advancements, international harmonization, changed working conditions, or the emergence of new hazards make current standards obsolete. As discussed below the Institute will balance industry's need for planning and adjustment time associated with future modules by having ample public involvement in setting the priorities for module selection and with judicious selection of transition periods.

NIOSH is aware of the needs of the respirator community to be able to plan future production and purchasing needs. This is true for consumers as well as manufacturers of respirators. NIOSH announced at the informal public meeting its intention to hold ample public meetings in advance of any proposed future modules so that these concerns could be addressed. The concerns expressed in the comments can be addressed in these informal public meetings and with the use of appropriate transition periods.

NIOSH intends to establish transition periods for implementing the requirements of each module. These transition periods will be determined by an assessment of the industry's ability to adopt the new requirements, ongoing transition periods from prior modules, and the public health implications of the changes.

Anticipated subjects and sequence of the NIOSH rulemaking were outlined in the proposed rule. Numerous comments were received providing suggestions for additional module subjects and their priority. Suggested additional subjects included powered air-purifying respirators, smoke masks, fit testing, supplied air respirators, gas masks, and combination respirators. Suggestions on scheduling priorities indicated a diversity in perceived needs. Based on the public interest in the future module



subject areas and timetable, NIOSH will conduct a public meeting to further develop the schedule with input from all interested parties. The location and date for this meeting will be announced in the **Federal Register**, *Morbidity and Mortality Weekly Report* (MMWR), and other media.

The Institute coordinated the development and implementation of the modular approach with OSHA and MSHA. The specific requirements of this first module were reviewed and accepted by both agencies to ensure that 42 CFR part 84 properly links with OSHA and MSHA respirator use regulations. Both agencies will participate in the development by NIOSH of appropriate user guidelines. NIOSH and MSHA developed a Memorandum of Understanding to delineate roles for the continuing joint approval under 42 CFR part 84 of respirators used for mine emergencies and mine rescue. The Institute will continue to collaborate with MSHA and OSHA as future modules are developed.

#### B. User's Guide

The proposal stated the intent to develop a user's notice or guide to explain the use of respirators certified for protection against particulate exposures under the new 42 CFR part 84 that would replace the existing filter respirators certified under 30 CFR part 11 subparts K and M. Commenters indicated that this user's guide should be developed in a public forum with public involvement. One commenter stated that the user's guide should be issued prior to the finalization of part 84. Another believed that its availability should coincide with the publication of the final rule. Constraints on releasing specific information as to the contents of the final rule prior to its publication limits the availability of information needed for development of a user's guide, thus making its development with public input prior to or concurrent with this rule impossible. NIOSH agrees with the commenters that public input into the user's guide will result in a better product. An informational respirator user's guide for part 84 respirators will be developed with public involvement.

The user's guide will address both the use of part 11 and part 84 respirators during the transition period. Assigned Protection Factor (APF) values are used in the respirator selection process to indicate the expected protection level for the respirator wearer. NIOSH recommends APFs for respirators certified under 30 CFR part 11 in its *Guide to Industrial Respiratory Protection* and in the *Respirator*

*Decision Logic*. The future user's guide will recommend APFs appropriate for use with the part 84 particulate respirators until APFs can be addressed through future rulemaking. It will also provide information and recommendations on a variety of other respirator use issues associated with this current rulemaking.

During review of this rule, both OSHA and MSHA expressed strong interest in the APF values for the new part 84 particulate filter classifications. Both agencies agreed with NIOSH that APFs could not be addressed properly in this first module. They therefore urged NIOSH to develop a subsequent module defining APFs for all respirators. In the interim, OSHA regulations under Title 29 and the MSHA regulations under Title 30 will allow the use of the new part 84 particulate classifications with the APFs to be established by NIOSH in the users' guide. OSHA is in the process of updating its respirator use regulations, and the current proposal specifies acceptance of APFs developed and promulgated under part 84.

#### C. Use of Particulate Respirators for Protection Against TB

While the requirements in this final rule were not developed specifically to certify respirators against biological agents, this rule will address the important public health need to control the transmission of *Mycobacterium tuberculosis*, the causative agent of TB, in health-care and other facilities through the use of respiratory protective devices.

In response to the recognized risk of TB transmission in health-care facilities, increases in TB in many areas, and recent outbreaks of multidrug-resistant TB, CDC published "Guidelines for Preventing the Transmission of *Mycobacterium tuberculosis* in Health-Care Facilities, 1994", in the **Federal Register** (59 FR 54242) and *MMWR* (Volume 43, No. RR-13) on October 28, 1994. These guidelines enumerate four performance criteria that CDC has determined are necessary for respiratory protective devices used in health-care settings for protection against TB. The only currently certified air-purifying respirator class that meets all the respiratory protection performance criteria in the CDC Guidelines is a respirator with a high efficiency (HEPA) filter. Many comments were received from the health-care community supporting the positive impact of the proposed rule on compliance with the CDC Guidelines.

All nine classes of air-purifying, particulate respirators to be certified under the provisions of the new

particulate filter tests (filter efficiency) in part 84 meet or exceed the performance recommendations contained in the CDC Guidelines. Several of these new classes of air-purifying, particulate respirators are expected to be less expensive than respirators with HEPA filters. Consequently, implementation of the modifications included in this rule should promote a substantial increase in respiratory protection provided to health-care and other workers potentially exposed to the *M. tuberculosis* droplet nuclei in health-care and other occupational settings.

#### D. Conversion From 30 CFR Part 11 to 42 CFR Part 84

Since 1974, the Mine Enforcement and Safety Administration (MESA), MSHA, and the Occupational Safety and Health Administration (OSHA) have regulated the selection, use, and maintenance of respirators in the workplace under their respective enforcement authorities. NIOSH is not including the requirements of §§ 11.2 and 11.2-1 with this redesignation to 42 CFR part 84. Sections 11.2(a) and 11.2-1 refer to respirator use and selection criteria that since have been superseded by OSHA and MSHA respirator regulations.

Section 11.2(b) allows for the continued manufacture and sale of gas masks approved under the former U.S. Bureau of Mines (BOM) Schedule 14F (dated April 23, 1955). This Schedule was replaced by the requirements in Subpart I of 30 CFR part 11 in 1972. Gas masks approved under Subpart I of 30 CFR part 11 (14G canisters) are widely available and only a limited number of types of 14F canisters are marketed. MSHA experience indicates that few of the 14F respirators are currently sold or used. MSHA also indicated that removal of the provisions in § 11.2(b) would remove the authority to market these respirators as approved devices.

NIOSH is not transferring the requirements of § 11.2(b) to 42 CFR Part 84 since NIOSH does not have the capability to process applications for these respirators. The approval records on these BOM-approved respirators no longer exist and therefore NIOSH has no way of monitoring the production of these respirators to assure that they continue to meet the approved design. Thus, NIOSH will not authorize the sale and shipment of the Schedule 14F respirators under this part 84.

In addition, the codification of the redesignated sections into a non-hyphenated numbering system results in several general heading sections that contained no substantive requirements



not being included in this redesignation. These include §§ 11.85, 11.102, 11.124, 11.140, and 11.162.

NIOSH is making a limited revision to the existing requirements of 30 CFR part 11 in this first module, requiring updated particulate filter tests. This revision eliminates the need for unique tests for particulate respirators used for different types of aerosols, such as dust/mist, dust/fume/mist, paint spray, and pesticides. The new certification tests use the most penetrating aerosol size, 0.3 $\mu$ m, and either a non-degrading particulate, sodium chloride, or a highly degrading oil, dioctylphthalate. Consequently, particulate filters certified under these new procedures can be used without regard to aerosol size, taking into consideration only the degrading or nondegrading nature of particulates and the APF required by exposure concentrations. To revise respirator nomenclature to be consistent with this fundamental change in certification philosophy, the words dust, fume and mist are replaced with particulate in the final rule.

Existing subpart M of part 11 (§§ 11.170 through 11.183-7) addresses the requirements for pesticide respirators. The requirements of subpart M are not included in this redesignation to 42 CFR part 84. This rule eliminates this category and the tests specific to it, leaving subpart M reserved. All references to subpart M and pesticides as a classification for approval are eliminated. NIOSH will discontinue issuance of certifications that classify these respirators as suitable for use against a specific particulate.

The existing test requirements in §§ 11.124-21 through 11.124-24 specify that a test subject wearing the respirator be exposed to an abrasive blasting environment in which the blasting agent is composed of 99+ percent free silica (SiO<sub>2</sub>). This requirement is not included in this redesignation to 42 CFR part 84. The purpose of this requirement was to determine the adequacy of protection provided in such environments. NIOSH administratively suspended such tests over 20 years ago because they placed test subjects at risk of exposure to fractured crystalline silica. These tests are not included in this final rule. Requirements for abrasive blasting and other atmosphere supplying respirators as well as fit testing for all respirator types will be addressed in a future module. In the interim, NIOSH will continue the administrative policy of the past two decades of conducting quantitative fit testing in lieu of the tests stipulated in §§ 11.124-21 through 11.124-24.

Two comments recommended the inclusion of administrative policies to the rule. One commenter suggested that §§ 11.124-21 through 11.124-24 (referring to air-line respirators) be restored or replaced with the current administrative policy of quantitative fit testing. Another commenter was concerned that the NIOSH policy of allowing a mixed-gas Self Contained Breathing Apparatus for fire fighting was not included in the proposed rule. NIOSH agrees with these commenters that administrative policies related to specific changes in a module should be incorporated. However, the topics of concern to these commenters addressed administrative policies in subject areas that were not proposed to be changed in this module, therefore, they have not been incorporated.

NIOSH has not included the test procedures of §§ 11.124-21 through 11.124-24 due to NIOSH's concern of health risks to test subjects during pre-submission testing performed by a manufacturer seeking approval of a respirator intended for use in an abrasive blasting environment. Although no Type AE or BE respirators have ever been certified, Type AE, BE, and CE respirators may be certified for use in an abrasive blasting environment. These respirators will be tested using Air-supplied Respirator Section Test Procedure Number 23 Abrasive-Blast, Type CE. Copies of this procedure are available from the Certification and Quality Assurance Branch, 1095 Willowdale Road, Morgantown, West Virginia, 26505-2888.

#### *E. MSHA's Regulatory Role*

The final 42 CFR part 84 regulation is consistent with the current MSHA and NIOSH respirator approval program, placing responsibility for certifying most respirators with NIOSH. MSHA and NIOSH will continue to jointly review and approve respirators used for mine emergencies, mine rescue, and the associated service-life plans, user's manuals, and other documentation. Among the types of devices for which this role is particularly important are self-contained self-rescue devices. The final rule preserves MSHA's current role in the certification of such respirators whose unique use in mining is an important part of safeguarding the health and safety of miners. In addition, MSHA will continue to test electrical and electronic components of respirators for use in potentially explosive atmospheres in gassy underground mines and issue a separate MSHA approval under 30 CFR part 18 for the electrical components of such respirators.

In implementing the final regulation, NIOSH and MSHA have developed a new Memorandum of Understanding (MOU) that reflects administrative matters related to respirator approval, including immediate notification to MSHA of field complaints and identified deficiencies concerning approved respirators. Three commenters recommended that the public be allowed to review and comment on the MSHA/NIOSH Memorandum of Understanding. It was indicated by an agency representative that such comments on the contents of the MOU would be welcomed. Two of these commenters were concerned that the responsibilities and accountability, specifically MSHA's involvement in the certification of mining-specific respiratory protective devices, be maintained in the Memorandum of Understanding. The third commenter was unsure if the Memorandum of Understanding would have an effect on the notice of public rulemaking. Comments submitted subsequent to the public meeting reiterated the concerns stated at the meeting. These comments were considered in the MOU's development and have subsequently been addressed. Copies of the MOU will be available from NIOSH and MSHA.

The new Memorandum of Understanding between MSHA and NIOSH delineates the interaction between the agencies in carrying out the responsibilities and authorities provided for in the Mine Safety and Health Act of 1977 (30 USC § 801 et seq) and this final rule. It defines the method of implementation of the regulation and has no effect on its content. The agency has determined that this MOU is most appropriately developed between the two agencies and thus, commenters did not directly participate in the development of the MOU. As indicated above, public comments on the MOU are welcome.

#### *F. Transition Period*

The proposal included provisions for phasing out part 11 particulate respirators. Specifically, no applications were to be accepted after the effective date of part 84, with a maximum of 6 months for processing in-house applications. Sale and shipment (distribution) of part 11 particulate respirators would have been allowed for only 2 years from the effective date of part 84.

Several commenters indicated that these transition periods were much shorter than the 5-year phase-out period proposed by NIOSH in 1987. Some comments on the proposed schedule stated that there must be an appropriate



time to develop new products, receive certification, and initiate production of the new respirators. Commenters were also concerned the use of the term distribution implied manufacturer control of the distributor system and the resale market. Several commenters recommended 4 years for NIOSH-processing of part 11 applications, and for sale and shipment of part 11 respirators. NIOSH is expanding the phase-out period from two to three years to address these concerns.

With the effective date of part 84, MSHA and NIOSH will no longer accept applications for new approvals or extensions of approval of respirators under part 11 provisions. All applications received after the effective date of part 84 will be considered as applications for a new or extension of approval under part 84. Valid part 11 applications that were received prior to the effective date of part 84 will be processed for approval under part 11 provisions. A subpart KK containing the part 11 requirements for particulate respirators has been added to the final rule to provide continued authority for NIOSH to issue extensions of approvals needed to address respirator recall and retrofit matters that are associated with health and safety issues for workers. Respirators listed as certified under the provisions of 30 CFR part 11, subparts K or M, may not be sold or shipped by the approval holder as NIOSH/MSHA certified respirators effective July 10, 1998. Continued use of distributed particulate respirators is under the jurisdiction of OSHA and MSHA and therefore is not affected by this rule. Because certifications will not be revoked for part 11 devices sold and shipped by the approval holder prior July 10, 1998, NIOSH anticipates that OSHA and MSHA would permit continued use of those part 11 respirators.

This 3 year period was selected to ensure the timely replacement of the part 11 respirators that exhibit low initial efficiency levels while allowing an ample supply of respirators to remain available for use. This timeframe will provide sufficient time for manufacturers to have respirators approved and manufactured in quantities to meet demand. Manufacturers' comments to the proposed rule support this timeframe, as some manufacturers appear ready to provide part 84 respirators immediately. At least one commenter stated, without reservation, preparedness to submit applications to meet the new requirements. Several commenters requested that NIOSH accept applications for part 84 respirators upon

publication, rather than the effective date of part 84. One manufacturer commented that NIOSH should anticipate at least 10 applications from each manufacturer upon part 84 becoming effective. NIOSH also expects a significant number of presently certified particulate respirators, in addition to new designs, to meet the requirements of this rule. Therefore, a high initial application rate for approval of part 84 particulate respirators is expected.

Some commenters expressed concern that NIOSH would not be able to expeditiously process the part 84 applications, thereby delaying introduction of the new respirators to the marketplace. Delays in processing the part 84 applications would prolong the time needed for transition to these new respirators. Division of the NIOSH staff and resources between processing part 84 applications and pending part 11 applications, along with routine extensions of existing part 11 particulate respirator certifications, may initially slow the certification and availability of part 84 respirators. However, the Institute has determined that it cannot reject without action part 11 applications that were validly prepared and submitted while the provisions of part 11 remain in effect. NIOSH therefore will process all valid part 11 applications that were received by NIOSH before the effective date of part 84. The authority for the approval holder to sell and ship particulate respirators under any part 11 certification issued under these conditions will expire along with the other part 11 certifications on July 10, 1998.

The new technical requirements of part 84 only address air-purifying respirators. Other classes of respirators, such as self-contained breathing apparatus, gas masks, etc., are not affected by the new filter penetration test requirements. Therefore, NIOSH intends to continue issuing new and extension of approval numbers in the same format designation (TC number) as issued under existing part 11 for those respirator types whose technical requirements for approval under part 84 have not been modified from existing part 11. A new approval number series will be initiated for the products whose technical requirements have been upgraded under part 84. By checking the approval number, respirator users will be able to quickly and easily distinguish those products that have demonstrated the improved performance requirements of the new part 84 from those that have demonstrated compliance with only the

existing part 11 standards that are transferred to part 84. NIOSH further intends to issue public notices of the new approval designations to be used for products demonstrating performance to the improved standards.

## VI. Discussion of Final Rule

### A. Certification Fit Testing

The proposal contained two sections (§§ 84.181 and 84.182) that would have retained the existing Part 11 particulate respirator fit test protocols using isoamyl acetate. These tests were proposed to redesignate the existing §§ 11.140-1 and 11.140-2 with the tests unchanged to minimize the scope of the changes proposed in the first module.

The currently required particulate respirator facepiece fit tests of part 11 use isoamyl acetate, an organic vapor, as the test agent. Under existing part 11, such tests are required for high efficiency (HEPA) and dust, fume, and mist (DFM) respirators, but not dust/mist (DM) respirators. Since particulate filters are not intended to filter organic vapors, the tested respirators must often be modified by the addition of an activated charcoal layer. This added charcoal layer prevents penetration of the isoamyl acetate through the filter so that the respirator-to-face fit can be evaluated. As a result, the certification program tests surrogate respirators that may have fitting characteristics that differ from the marketed (certified) respirators.

Numerous and varied comments were provided on these sections. A number of commenters suggested that NIOSH eliminate fit testing as a condition of certification. Two commenters recommended that the rule should require manufacturers to submit test data showing good fit characteristics in lieu of NIOSH conducting fit testing. Other commenters requested that NIOSH test the respirator-to-face fit, or otherwise assure that proper fitting characteristics were provided by every certified respirator. Several other commenters requested that fit testing be made a meaningful test. Several others suggested that a quantitative protocol rather than a qualitative fit protocol should be used. Two commenters stated support for the fit tests as proposed.

Several of the reasons given for eliminating fit testing were that fitting respirators to individuals in the certification program does not predict the fit of an individual wearer; fit testing of individual workers at the worksite is required by OSHA and that is the appropriate setting for fit testing; the isoamyl acetate test has not been validated; and, the isoamyl acetate test



has to be performed on modified respirators.

The comments requesting that fit testing be made a meaningful test were based on reasoning similar to those suggesting elimination of the test. In lieu of elimination, they suggested that some inadequacies could be resolved with modification of the test protocol to use a particulate aerosol, such as Bitrex, as the test agent. Changing the test protocol to test with a particulate would at least permit the tested respirator filters to be as certified, thereby eliminating specially-made surrogates.

Commenters endorsing NIOSH continuation of fit testing believed that the present certification process provides an assurance that the respirator will properly fit a given worker when use of the respirator is needed in the workplace.

The problems associated with testing the facepiece-fit in a certification program have been recognized for years. Efforts have been made to seek more meaningful test results; nevertheless, the validity of the test results remain questionable.

Successful fit testing in the certification process provides no assurance that the respirator will properly fit a given worker when used in the workplace. The only means presently available to assess the fit achieved on the worker is a respirator-to-face fit test conducted on that individual with the chosen respirator. Even this test procedure, conducted on the individual, cannot assure that the respirator will maintain a proper fit when use of the respirator is needed in the workplace. This concern is compounded when the fit is determined with a surrogate respirator.

During review of this rule, both OSHA and MSHA favored inclusion of respirator fit testing and fit checking procedures as part of NIOSH respirator certifications under the new part 84 particulate filter classifications. Both agencies accepted the determination by NIOSH that these issues cannot be properly addressed in this first module. Both agencies therefore urged NIOSH to develop a face fit module to include respirator fit testing and fit checking procedures for all respirators.

The purpose of face fit testing in the certification program has been to assure that respirators have generally good face fitting characteristics. However, at this time NIOSH does not have studies that define the effectiveness of either the isoamyl acetate or American National Standards Institute (ANSI)/OSHA accepted fit tests in predicting actual workplace protection provided to workers. NIOSH is presently conducting

research for this purpose. In the interim, lacking validation and correlation of testing protocols, workers' health concerns are best served through the application of fit-testing and fit-checking procedures on individual workers in a quality respirator program. Therefore, the isoamyl acetate fit tests proposed in §§ 84.181 and 84.182 are not included in this final rule. NIOSH will address issues associated with face-fit efficacy in a separate module upon completion of the necessary research.

#### *B. Powered Air-purifying Particulate Respirators*

The proposed regulation included filter efficiency requirements for powered air-purifying respirators (PAPRs). The solid and liquid and solid categories were to be tested with sodium chloride (NaCl) and dioctyl phthalate (DOP), respectively. The classes to be certified were the 99.97 and 99% efficiency levels. The remaining design and test parameters for PAPRs were retained from part 11 without change.

Commenters questioned why the efficiency levels proposed for PAPRs were not the same as non-powered respirators. The proposal specified three efficiency levels for non-powered (95, 99, 99.97) and only two levels for PAPRs (99 and 99.97). Commenters indicated many present filter cartridges are interchangeable between the non-powered and PAPR units, recommending corresponding filter efficiencies between the non-powered and PAPR units to retain this broader market for a filter design.

Numerous commenters stated a concern that the proposed requirements of subpart K did not adequately address PAPRs. These commenters indicated that the respiratory protection provided by PAPRs is dependent on the respirator components working together as a system. The proposed rule, focusing on filter efficiency, did not address the system requirements for these respirators. These commenters reasoned that the performance of these complicated respirator systems deserves special consideration because of unique problems addressing airflow, filter efficiency, and fit. These commenters suggested that the requirements for powered units be removed from subpart K, to be addressed in a separate module.

Other commenters addressing PAPR requirements stated concerns over sodium chloride (NaCl) filter test instrumentation capabilities. With the present state-of-the-art capabilities, the proposed PAPR loading requirements are difficult to achieve. This leads to a number of testing difficulties including instrumentation availability, time

consuming tests, reproducibility of results, and system costs. NIOSH agrees with these concerns and will address them in the forthcoming module.

Commenters to the proposal also acknowledged that the resultant part 84 filters would be a significant improvement over those currently certified and marketed under part 11. Two commenters recognized the concern over the performance of part 11 powered dust, fume, mist respirators. They indicated that this concern could be addressed by incorporating only part 11 high-efficiency filter requirements for PAPRs approved under part 84. NIOSH agrees and has revised the rule to permit the continued use of part 11 high efficiency filters for PAPRs approved under part 84.

NIOSH also agrees with commenters that the proposed filter efficiency requirements alone do not adequately address the operational parameters of PAPRs that should be revised. The sections of subpart K have therefore been modified to be applicable only to non-powered air-purifying particulate respirators. The requirements for the powered units will be addressed in a forthcoming module. In the interim, powered air-purifying particulate respirators equipped with HEPA filters will be approved under the provisions of subpart KK.

#### *C. Filter Classification*

The proposal provided for six classes of filters in a filter classification system with three filter efficiency levels and two categories of filter degradation resistance. The three efficiency levels (99.97, 99, and 95%) were determined by testing with the most penetrating aerosol size until a maximum loading of 200 mg was reached. The two degradation resistance categories were established by the choice of either NaCl or DOP as the test challenge aerosol. Sodium Chloride is only mildly degrading to filter media while DOP is a liquid oil that is highly degrading. Accordingly, filters tested with the NaCl aerosol were recognized as not highly resistant to degradation and only appropriate for use with solid aerosols in the workplace. Filters tested with the liquid DOP oil were recognized as highly resistant to degradation and considered appropriate for both liquid and solid workplace aerosols.

The categories and classes of filters that would have been certified under the proposal are summarized below:

Category	Class	Efficiency	Test agent
Solid and liquid .....	A	99.97	DOP



Category	Class	Efficiency	Test agent
Solid .....	A	99.97	NaCl
Solid and liquid .....	B	99	DOP
Solid .....	B	99	NaCl
Solid and liquid .....	C	95	DOP
Solid .....	C	95	NaCl

The behavior of filters to challenge by each of the two test aerosols depends on the filter type. Mechanical filters and electrostatic filters are the two fundamental types of particulate filters on the market. Mechanical filters' efficiencies are determined by mechanical features such as the diameter, orientation, and arrangement of the fibers that comprise the filter. Electrostatic filters have a static electric charge on the filter fibers to enhance the attraction and retention of the aerosolized particles. The enhanced efficiency due to the electrical charge means that an electrostatic filter generally offers lower breathing resistance than a mechanical filter with the same initial efficiency. This occurs because fewer fibers are needed in the electrostatic filter to achieve the same level of efficiency as a mechanical filter. However, the efficiency of electrostatic filters can be significantly reduced by exposure to certain aerosols while mechanical filters are generally more resistant to degradation.

Comments concerning resistance of filters to degradation were generally of two conflicting schools of thought. One school favored replacing the two proposed tests with a single, more severe test. The other favored retaining the two proposed tests at the same or reduced level of severity.

Commenters opposing the proposed classification system stated it was not a severe enough test of resistance to filter degradation because it did not represent a worst-case test. They recommended testing all filters with a DOP aerosol with the test continued until there was no further decrease in filter efficiency. Those supporting this position argued that the proposed filter classification system could result in overexposure of workers as workplace aerosols degrade some filters to a level below the certified efficiency level. It was indicated that various workplace contaminants can cause the beneficial filtering effects of the charge on electrostatic filters to become partially or totally ineffective without indication to the wearer. As the electrostatic charge on the filter fibers is masked by the deposition of aerosol, the efficiency of the filter can be reduced to below the anticipated level of protection, based on the certified efficiency level. Further, these

contaminants have been identified as solids as well as liquids. With no warning to alert the wearer of a decrease in the performance level of the filter, these commenters believed that the proposed tests to determine filter efficiency should be modified to assure that the filters are tested until the minimum level of efficiency is achieved. The stated advantage of such an approach is that filters could be used with any aerosol for indefinite time periods without concern of filter degradation.

The other school argued that the two proposed categories were either appropriate or too severe. They suggested continuing with the two categories either as proposed or with a reduction in the amount of filter loading (to reduce the severity of the test). They argued that the two proposed filter tests, being a combination of worst-case and severe test parameters, would assure adequate filter performance in the workplace.

Several commenters stated that the great majority of respirator applications are in worksites with aerosols that do not significantly diminish the efficiency level of the electrostatic filters. Workplace studies were submitted to support the conclusion that, because of the highly degrading nature of DOP and the proposed high loading level, the proposed test were many times more severe than conditions realistically encountered by workers. These commenters recommended, not only the certification of two categories as proposed, but that the proposed test loading levels for both the NaCl and DOP aerosols be reduced to more closely simulate workplace exposures.

The advantage of the proposed tests was the benefit of potentially lower breathing resistance, with the resulting increased comfort, of electrostatic filters for the great majority of respirator wearers who are not exposed to highly degrading workplace aerosols. Further, the electrostatic filter types were reported by commenters to have a potentially lower cost than their mechanical filter counterparts.

This final rule provides for the needs of both the majority workers with no need for filters highly resistant to degradation and workers needing filters most resistant to degradation. To that end, this rule provides for a third category of filters added to the two categories provided for in the proposal. The new filter category is tested with the highly degrading DOP until no further decrease in filter efficiency is observed.

As discussed under VI. Discussion of Final Rule, D. Section-by-Section

Discussion, § 84.170, NIOSH is introducing a new terminology for the three filter categories. The solid only filters in the proposal are labeled N-series filters in this final rule. The proposal's solid or liquid filters are now labeled R-series filters. Filters of the new, third category are labeled P-series filters. The three categories, therefore, provide filters for a complete range of applications.

Further, to address concerns about the use of A, B, and C in the proposal to indicate the efficiency level, the final rule uses numerical notations of 100, 99, or 95 to indicate filter efficiency. The rationale for retaining the proposed efficiency levels of 99.97, 99, and 95% is discussed in VI. Discussion of Final Rule, D. Section-by-Section Discussion, § 84.170(c)(3). The terminology of this final rule is related to that of the proposal as follows:

Final	Proposal
N100 .....	Solid only/type A.
N99 .....	Solid only/type B.
N95 .....	Solid only/type C.
R100 .....	Solid & Liquid/type A.
R99 .....	Solid & Liquid/type B.
R95 .....	Solid & Liquid/type C.
P100 .....	(Not included in proposal).
P99 .....	(Not included in proposal).
P95 .....	(Not included in proposal).

As stated in the proposal, NIOSH selected the test criteria to be a combination of worst-case and very severe test conditions. The N- and R-series filters will be tested to a specified maximum loading level as in the proposal. Performance of these two filter classes at loadings beyond that maximum will not be evaluated. Furthermore, NIOSH is aware that few data are available to assess the performance of these respirators in workplace settings over an extended period of time. Therefore, the N- and R-series filters will be certified with the recognition that in some settings time-use limitations should be applied. A single shift limitation, for example, may be appropriate to guard against possible degradation of performance below the efficiency certified by NIOSH. In addition to possible time-use restrictions, the N-series filters should be restricted to use in those workplaces free of oil aerosols because the N-series certification tests will involve challenge with non-degrading sodium chloride aerosols. The R-series filters should require no such aerosol-use restrictions because R-series certification tests will involve challenge with highly degrading dioctylphthalate aerosols. Because the P-series certification tests will involve challenge with this highly degrading



aerosol that will continue until the filter efficiency declines to its lowest level, the P-series may require neither aerosol-use nor time-use limitations. As for any filter, service time will be limited by considerations of hygiene and increased breathing resistance due to filter loading.

Guidelines for the use and selection of part 84 particulate respirators, as described in V. Administrative and Procedural Matters of Final Rule, B. User's Guide, are to be developed with public input. The user's guide will include detailed guidance concerning use limitations for these three filter series.

#### D. Section-by-Section Discussion.

All sections redesignated to 42 CFR part 84 without modification from 30 CFR part 11 are excluded in this discussion of the final rule. The sections redesignated without modification will be revised, where appropriate, to:

- (1) remove references to MSHA, except for those related to certain mining applications,
- (2) update the NIOSH certifying organization to the Certification and Quality Assurance Branch, Division of Safety Research, NIOSH, 1095 Willowdale Road, Morgantown, West Virginia 26505-2888,
- (3) remove references to subpart M, pesticide respirators, and tests for protection during abrasive blasting,
- (4) correct nonsubstantive typographical errors and reference the new part 84 section designations, and
- (5) update references to incorporation-by-reference documents.

The sections redesignated without modification are as follows:

84.1, 84.11, 84.12, 84.21, 84.22, 84.30, 84.31, 84.32, 84.34, 84.35, 84.36, 84.40, 84.41, 84.42, 84.43, 84.50, 84.51, 84.53, 84.60, 84.62, 84.63, 84.64, 84.65, 84.66, 84.70, 84.71, 84.72, 84.73, 84.74, 84.75, 84.76, 84.77, 84.78, 84.79, 84.80, 84.81, 84.82, 84.83, 84.84, 84.85, 84.86, 84.87, 84.88, 84.89, 84.90, 84.91, 84.92, 84.93, 84.94, 84.95, 84.96, 84.97, 84.98, 84.99, 84.100, 84.101, 84.102, 84.103, 84.104, 84.110, 84.111, 84.112, 84.113, 84.114, 84.115, 84.116, 84.117, 84.118, 84.119, 84.120, 84.121, 84.122, 84.123, 84.124, 84.126, 84.130, 84.131, 84.132, 84.133, 84.134, 84.135, 84.136, 84.137, 84.138, 84.139, 84.140, 84.141, 84.142, 84.143, 84.144, 84.145, 84.146, 84.147, 84.148, 84.149, 84.150, 84.151, 84.152, 84.153, 84.154, 84.155, 84.156, 84.157, 84.158, 84.159, 84.160, 84.161, 84.162, 84.163, 84.172, 84.173, 84.174, 84.175, 84.176, 84.178, 84.182, 84.190, 84.191, 84.192, 84.193, 84.194, 84.195, 84.196, 84.197, 84.198, 84.199, 84.200, 84.201, 84.202, 84.204, 84.205, 84.207, 84.250, 84.251,

84.252, 84.253, 84.254, 84.255, 84.256, 84.257, and 84.258.

The following section-by-section analysis discusses each new or revised section to 42 CFR part 84. All part and section references for part 11 are to Title 30 of the Code of Federal Regulations (30 CFR). All part and section references for part 84 are to Title 42 of the Code of Federal Regulations (42 CFR).

### Subpart A—General Provisions

#### Section 84.2—Definitions

This section is redesignated and revised from § 11.3. This section is unmodified from the proposal.

The existing definitions for air contamination level, Bureau, concentration limits for radionuclides, DOP, MESA, pesticide, radionuclides, and smoke are deleted. These terms are used in provisions that are modified or deleted as a result of the filter penetration test changes included in this final rule. These definitions have, therefore, become unnecessary.

The existing definition for Testing and Certification Laboratory is modified to reflect the present name of the organization as the Certification and Quality Assurance Branch. One commenter suggested the definition of respirator be modified to require a respirator to have one-way airflow with inspiratory and expiratory valves, able to be properly positive and negative fit-checked under usual working conditions. Additionally, this commenter recommended adding a definition for mask as any device that protects the wearer against inhalation of a hazardous atmosphere.

The primary purpose of a respirator is to provide respiratory protection for the wearer. Neither requiring inhalation and exhalation valves nor reclassifying respirators as masks would enhance worker protection. Thus NIOSH retained the current definition.

#### Section 84.3 Respirators For Mine Rescue or Other Emergency Use In Mines

This section is new and maintains MSHA's role in the approval of respirators designed for mine rescue or other mine emergency use. This section is unmodified from the proposal. Under this provision, MSHA and NIOSH will conduct joint review and certification of respirators used for mine emergencies and mine rescue. This provision recognizes MSHA's expertise in identifying the special needs and considerations for respirators used in the mining environment. This role replaces MSHA's existing role as a joint approver of all respirators. Several

commenters, while endorsing the transfer of the authority for the regulation, recognized MSHA's unique expertise relating to mine-specific respiratory protective devices. These commenters strongly supported MSHA's continued close involvement in this equipment including, but is not limited to, filter self-rescuers, self-contained self-rescuers, and emergency rescue equipment.

Paragraph (a) specifies that NIOSH and MSHA will jointly certify any respirator designed for mine emergencies, mine rescue or other emergency use in mines. This joint review and certification includes any associated service-life plans, user's manuals, and other supporting documentation. This paragraph further specifies that certifications for these respirators include any identified use limitations related to mine safety and health as a condition of certification.

Paragraph (b) specifies NIOSH and MSHA will jointly address recall and retrofit matters arising from field complaints or identified deficiencies concerning any respirators used in the mining environment. A new Memorandum of Understanding is to further delineate MSHA's role in such matters, including participation in any related field or manufacturing site audits.

### Subpart B—Application for Approval

#### Section 84.10 Application Procedures

This section is redesignated from existing § 11.10 with only paragraph (e) modified. This section is unmodified from the proposal. Paragraph (e) retains the existing requirement for inspection, examination, and testing by MSHA of electrical and electronic components to be permissible in accordance with 30 CFR part 18 for respirators intended for use in mining environments and having permissible electrical or electronic components. MSHA will continue to conduct this testing and issue a separate MSHA approval number for those respirators found acceptable. The process for conducting the permissibility evaluation of these components and their identification remains unchanged from the existing policies and practices.

### Subpart C—Fees

#### Section 84.20 Examination, Inspection, and Testing of Complete Respirator Assemblies; Fees

This section is redesignated from existing § 11.20, and modified only to reflect the new particulate filter classification scheme. This section is unmodified from the proposal.



**Subpart D—Approval and Disapproval***Section 84.33 Approval Labels and Markings; Approval of Contents; Use*

This section is redesignated from existing § 11.33. This section is unmodified from the proposal.

Paragraph (b) specifies the use of the NIOSH emblem on the approval label, replacing the MSHA emblem.

Paragraph (e) of this section is modified to identify the existing dust, fume, and mist class of respirator as a particulate respirator. The new designation is consistent with the testing criteria under which these respirators are certified. The table in paragraph (e) identifying the approval label requirements is modified by the removal of references specific to paint spray and pesticide respirators, also consistent with the changes associated with the non-powered air-purifying particulate filter efficiency level determination test.

**Subpart F—Classification of Approved Respirators; Scope of Approval; Atmospheric Hazards; Service Time***Section 84.52 Respiratory Hazards; Classification*

This section is redesignated from existing § 11.52. This section is unmodified from the proposal.

It is modified only to delete paragraph (d). Reference to the pesticide classification is no longer appropriate with the introduction of the particulates classification.

**Subpart G—General Construction and Performance Requirements***Section 84.61 General Construction Requirements*

This section is redesignated from § 11.61. This section is unmodified from the proposal.

The provision for respirator components to meet the permissibility requirements of 30 CFR part 18 [paragraph (e)] has been deleted because MSHA's workplace regulations separately and independently establish this requirement for certain mining applications. This change is consistent with existing practice, whereby, MSHA conducts the evaluation and testing of these components and issues a separate approval to cover this aspect of respirator design.

**Subpart I—Gas Masks***Section 84.125 Particulate Tests; Canisters Containing Particulate Filters; Minimum Requirements.*

This section is redesignated from existing § 11.102-4, without modification except to specify the new

requirements that respirators for protection against particulates (dusts, fumes, mists, and smokes) in combination with gases, vapors, or gases and vapors, must meet. Except for reference to the redesignated section numbers of subpart K, this section is unmodified from the proposal. With the exception of the airflow resistance test of § 84.181, these respirators are required to meet the requirements specified in §§ 84.170 through 84.183.

**Subpart K—Non-Powered Air-Purifying Particulate Respirators***Section 84.170 Non-Powered Air-Purifying Particulate Respirators; Description*

This section, derived from § 11.130, is revised to define non-powered air-purifying particulate respirators in a more concise way than previously provided for respirators designed for protection against dusts, fumes, mists, paint sprays, and pesticides. An essential benefit to filter-mask purchasers of new certifications under this part is that they will no longer have to be knowledgeable about the contaminant particle sizes. Under the provisions of this part, NIOSH will certify filter performance with a test aerosol size chosen so that filter performance for essentially all other aerosol sizes will be higher than that certified by NIOSH.

Paragraph (a) describes non-powered air-purifying particulate respirators as those with air drawn through the air purifying filter as a result of the negative pressure generated with the inhalation of the wearer. Non-powered respirators include respirators that depend solely on the inhalation and exhalation of the wearer to provide an adequate supply of purified breathing air to the wearer. These respirators are designed with filters to provide respiratory protection against atmospheres that contain adequate oxygen to support life and are contaminated with particulates not immediately dangerous to life or health. Particulates for which these respirators provide protection include contaminants such as dusts, fumes, mists and smoke.

Paragraph (b) establishes three series of non-powered air-purifying particulate respirators designated as N-series, R-series, and P-series. The N-series respirators are intended for use in those workplaces free of oil aerosols. The R-series and P-series respirators are intended for removal of any particulate that includes oil-based liquid particulates.

Paragraph (c) establishes the classification of non-powered air-

purifying particulate respirators according to the efficiency level of the filter(s) when tested to the requirements of part 84.

Paragraph (c)(1) requires N100, R100, and P100 filters to demonstrate a minimum efficiency level of 99.97 percent.

Paragraph (c)(2) requires N99, R99, and P99 filters to demonstrate a minimum efficiency level of 99 percent.

Paragraph (c)(3) requires N95, R95, and P95 filters to demonstrate a minimum efficiency level of 95 percent.

As discussed previously, some commenters supported the two-classification system that was proposed while others stated only one class was needed. NIOSH agrees with commenters that a class of respirators should be available for use in environments where the filter efficiency level is not diminished by the worksite aerosol (N-series). Insufficient studies have been conducted to definitively characterize workplace aerosols and their effect upon filter efficiencies. Therefore, NIOSH will certify the new filter categories recognizing potential aerosol-use and time-use limitations as discussed above and in VI. Discussion of Final Rule, C. Filter Classification.

Many commenters expressed concerns of confusion in the selection of the proposed new particulate respirators. Various commenters pointed to the proposed multiple (two) classes, class nomenclatures (Solid Only and Liquid and Solid), type nomenclature (A, B, and C), and filter color requirements as sources for this confusion.

Several commenters recommended that the designations (A, B, and C) for the types be changed to eliminate confusion of the particulate respirator classes with other approved respirator types. Some of these commenters suggested nomenclatures similar to P3, P2, and P1 used for particulate filters in the European community. Another of these commenters recommended a further delineation of the alphabetic notation with each type and class designated by a unique letter (A, B, C, D, E, and F) for clarification. Still another commenter suggested that the nomenclatures be changed but made no specific suggestion.

To address concerns about confusion in the selection of respirators under part 84, NIOSH has developed new category classifications and will develop a user's guide, as discussed in V. Administrative and Procedural Matters of Final Rule, B. User's Guide.

Numerous comments were also received regarding the proposed efficiency levels. Many commenters



supported the three efficiency levels as proposed, while others suggested levels different than proposed. A 90% filter efficiency level was the most frequently recommended alternative, sometimes suggested as a fourth class.

NIOSH recognizes that the efficiency requirements contained in the proposed rule are to some extent technology-forcing. However, HEPA-level respirators that perform at an efficiency level proposed under part 84 have been available for years. One commenter (a manufacturer) stated that the technology for producing 95% (Class C) efficiency level respirator is practical, reasonable, and available. This commenter further stated that a Class C respirator could be marketed at a price not exceeding the price of a 30 CFR part 11 disposable DFM respirator.

The principal advantage of a 90% efficiency class would be to permit a larger percentage of filters certified under part 11 to be certified without modification under the new part 84 tests. The best performing of the current DM and DFM respirators are expected to meet the requirements of a 95% class, but a significant number of DM respirators would not be expected to meet the requirements even of a 90% class. Limiting the minimum filter efficiency to 95% will minimize worker exposure to airborne contaminants from filter penetration. This is important because it is the most controllable element of protection afforded by respiratory protection programs. The human variables in these programs are more difficult to guarantee: that workers are provided the appropriate class of respirator; that the workers are effectively fit tested; that they achieve and maintain an effective face seal each time they wear a respirator; and that they replace disposable respirators and filters before their effectiveness is diminished. Some commenters urged, for these reasons, that all filters should have greater than 99% efficiency. Such high filter efficiency poses technologic challenges, increases costs to manufacturers and users, and increases breathing difficulty for respirator wearers. NIOSH believes that a 95% minimum efficiency best balances the public health concern and these competing considerations.

Although a number of manufacturers have indicated they are prepared now to submit filters for certification under these new test procedures, there may be some who are not. These manufacturers will have three years to develop this capacity while they continue to market their existing products.

#### *Section 84.171 Non-powered Air-purifying Particulate Respirators; Required Components*

This section is redesignated from existing § 11.131, modified only to incorporate the new terminology of particulates to describe dusts, fumes and mists. This section is unmodified from the proposal, except for the title change.

#### *Section 84.177 Inhalation and Exhalation Valves; Minimum Requirements*

This section is redesignated from existing § 11.137, modified only to delete reference to the silica dust tests for single-use respirators of § 11.140-5. This section is unmodified from the proposal. The respirator performance requirements of these tests are replaced by the non-powered air-purifying particulate filter efficiency level determination test contained in this rule.

#### *Section 84.179 Non-powered Air-purifying Particulate Respirators; Filter Identification*

This section requires the identification of non-powered air-purifying particulate respirators by labeling with a new classification system for the series and efficiency of the filters. The new terminology of non-powered air-purifying particulate respirator replaces the existing dust, fume, and mist respirator, as discussed previously.

The requirement for the manufacturer to specify the filter-series and efficiency level classification in the certification application is contained in paragraph (a). This classification would include the series of the filter and the expected efficiency of the filter based on the test requirements specified in § 84.182.

The information to be included on the label of a filter for a certified non-powered air-purifying particulate respirator is specified in paragraphs (b)(1) through (b)(9). This labeling defines the efficiency level achieved in the performance testing (i.e., 99.97%, 99%, or 95%) and the series of the filter (i.e., N, R, or P). This information is necessary to allow the user to make an informed decision on selecting the appropriate respiratory protection.

To facilitate this selection process, the P100 filters are color coded magenta to allow them to be easily distinguished from the other filter types. The filters other than the P100 can be of any color except magenta. This color coding is consistent with the present universally accepted color code convention which identifies the best performing filters (HEPAs) by their magenta color.

NIOSH has modified these labeling requirements from the proposal in agreement with the commenters who stated that the labelling should clearly state the certified efficiency rating numerically and include the series on the filter, filter package, or respirator box.

One commenter suggested that all classes of certified respirators should be color coded for user identification; another stated that the high efficiency filters of each series should be magenta. It was also requested that color coding as well as letter designation be specified for all respirators. A more complex color-coding system may add confusion to the respirator selection process. With the more descriptive classification identifying labels required by this final rule, the potential for confusion in selection of the appropriate respirator has been reduced. Therefore, NIOSH has not adopted these suggestions.

#### *Section 84.180 Airflow Resistance Tests*

Section 84.180 is derived from § 11.140-9. It is modified to delete the final inhalation resistance requirements. The non-powered air-purifying particulate filter efficiency level determination tests are not designed to simulate loading of the filter at the worksite. Therefore, these requirements are not appropriate with the introduction of these new tests.

Paragraph (a) provides for determining the inhalation-resistance of the complete non-powered air-purifying particulate respirator. This value corresponds to the pressure drop across the complete respirator mounted on a test fixture with air drawn inward through it at a continuous rate of 85±2 liters per minute. Tolerance limits have been added to the test flow rates as suggested by commenters.

The final rule does not include final breathing resistance limits as requested in some comments. The final breathing resistances previously included in the 30 CFR part 11 requirements were based on filters loading and clogging with a silica dust. The loading experienced at actual worksites is not represented by such a test. The inclusion of final breathing resistances as part of a certification would primarily address two concerns. The first is that the breathing resistance does not exceed physiological limits or pose undue discomfort on the wearer. Wearers will replace filters before breathing resistances reach such levels. The second concern is that the filter efficiency is still at an acceptable level at the certification final resistance value. The filter efficiency level determination



and respirator classifications provided for in this rule are sufficiently severe to alleviate this concern.

One commenter questioned NIOSH's intent for restricting final inhalation resistance for particulate filters used in conjunction with chemical cartridges. This commenter pointed to § 84.203 requirements which specify maximum allowable final inhalation resistances for these combinations. The final inhalation value is to be measured at the end of the service life tests for the chemical cartridge portion of the combination. NIOSH will continue to measure the initial and final inhalation and exhalation resistances of the combination in conjunction with the service life test of the chemical cartridge. The inhalation and exhalation resistances need not be measured for these combinations in conjunction with the particulate efficiency level determination tests.

Paragraph (b) states the inhalation resistance of the complete respirator is not to exceed 35 millimeters of water-column height. The exhalation resistance of the complete respirator is not to exceed 25 millimeters of water-column height.

The proposed rule would have limited the inhalation and exhalation resistances to 30 and 20 millimeters of water-column height, respectively. Several commenters requested that the values be increased. Increased breathing resistance values will permit the effective use of presently available filter material in respirators re-designed to meet the efficiency level determination tests at a reasonable cost. Others expressed a concern that respirators with higher breathing resistances are less likely to be fitted properly, often intentionally due to the discomfort. Commenters expressed that this may be true in the health-care profession where the use of certified respirators is new.

The final rule has increased the maximum acceptable breathing resistance values slightly from the proposed levels to those suggested by commenters. The proposed resistance levels of 30 and 20 millimeters of water-column height corresponded to the maximum allowable resistance values in part 11 for any particulate respirator. The new resistance levels remain below the acceptable limits for some non-particulate respirator classes under the existing part 11 provision. For example, chemical cartridge respirators, which have use patterns similar to particulate filter respirators, have a maximum initial inhalation resistance of 40 millimeters water-column height. This increase in acceptable breathing resistance for particulate respirators will

enable manufacturers to produce respirators meeting the new requirements more expeditiously and at lower cost than the proposal would have allowed. This small increase in maximum allowable breathing resistance for particulate respirators does not add substantially to physiologic burden for respirator users, and will be compensated by increased worker protection provided by the new filter efficiency tests and classification system. The acceptable breathing resistance levels for the non-particulate respirator classes are not affected.

#### *Section 84.181 Non-powered Air-Purifying Particulate Filter Efficiency Level Determination*

This section is new and specifies the test criteria and acceptable performance criteria for the new non-powered air-purifying particulate filter efficiency level determination. This section has been retitled from particulate instantaneous-penetration-filter test in response to a comment. The new title more appropriately represents the intent of the tests in this section to determine the efficiency level of the filters.

Paragraph (a) requires the filter efficiency testing of 20 filters of each non-powered air-purifying particulate respirator model. Testing is conducted using a solid sodium chloride or equivalent particulate aerosol for N-series certification or a dioctyl phthalate or equivalent liquid particulate aerosol for R-series and P-series certification.

Paragraph (b) requires the filters, including holders and gaskets; when separable, to be tested mounted on a test fixture in the manner as used on the respirator. This provides for testing of the assembly in a configuration as it will be actually used.

Paragraph (c) describes preconditioning requirements for the 20 N-series filters to be tested. After removal from their packaging, the 20 filters are placed in an environment of 85±5 percent relative humidity at 38±2.5 °C for 25±1 hours. The filters shall be stored in a gas-tight container until tested. Testing for the filter efficiencies must be performed within 10 hours following preconditioning. These preconditioning requirements apply only to N-series filters differing from the proposal which would have had filters of each series subjected to preconditioning.

Paragraph (d) provides for blocking the exhalation valves to ensure that any valve leakage is not included in the filter efficiency level evaluation. This only applies when the filters do not have separable holders and gaskets.

Paragraph (e) specifies the continuous test aerosol flow rates for the filter efficiency testing. Single filters are tested at a rate of 85±4 liters per minute; filters used in pairs are tested at a rate of 42.5 ± 2 liters per minute through each filter.

Paragraph (f) describes the penetration test aerosols and the test criteria to be used. A sodium chloride or equivalent solid aerosol is used when testing for filter efficiency for N-series filters. A neutralized-dioctyl phthalate (DOP), or equivalent oil, liquid aerosol is specified as the testing agent when testing for filter efficiency of R- and P-series filters. For P-series filters, the filter efficiency test will be continued until minimum efficiency is obtained. However, for N- and R-series respirators it will be terminated when an aerosol mass of 200±5 mg has contacted the filter unit, if minimum efficiency has not been obtained.

Paragraph (f)(1) identifies the test conditions for the sodium chloride or equivalent solid aerosol to be at 25±5 °C and relative humidity of 30±10 percent. The aerosol specified to be used in these tests will be neutralized to the Boltzmann equilibrium state, and the maximum concentration will not exceed 200 mg/m<sup>3</sup>. The relative humidity of the sodium chloride aerosol has been changed from the proposal in response to a comment. This change, a small increase in the relative humidity of the aerosol, allows testing at the values normally encountered with the test instruments commonly used.

Paragraph (f)(2) specifies the DOP or equivalent oil liquid particulate aerosol. The test conditions for the liquid aerosol are specified to be at 25±5 °C. The aerosol specified to be used in these tests will be neutralized to the Boltzmann equilibrium state, and the maximum concentration will not exceed 200 mg/m<sup>3</sup>.

Paragraph (g) specifies the particle size limitations at the test conditions for the filter efficiency test aerosols. The sodium chloride aerosol will have a particle size distribution with count median diameter between 0.075±0.020 micrometer and a standard geometric deviation not exceeding 1.86. The liquid particulate aerosol has a particle size distribution with count median diameter between 0.185±0.020 micrometer and a standard geometric deviation not exceeding 1.60. NIOSH will make these particle size distribution determinations at the specified test conditions with a scanning mobility particle sizer (SMPS) or equivalent. The specification of a scanning mobility particle sizer represents newer technology than the



differential mobility particle sizer that was specified in the proposal. This reference to the newer technology was added in response to comments from the public. NIOSH will accept manufacturer's size verification data determined by SPMS or an equivalent particle sizing instrument that provides particle sizing information consistent with an SPMS.

Paragraph (h) requires the efficiency of the filter (i.e., the amount of aerosol particles that pass through the filter) to be monitored and recorded throughout the test period by a suitable forward-light-scattering photometer or equivalent instrumentation.

Paragraph (i) requires the minimum filter efficiency for each of the 20 filters to be determined and recorded. The minimum efficiency of each tested filter is to be greater than or equal to 99.97% for P100, R100 and N100 filters; 99% for P99, R99 and N99 filters; and 95% for P95, R95 and N95 filters.

Many comments were received on all aspects of the testing requirements. Comments were received regarding the proposed loading levels, test agents, preconditioning requirements, number of filters to be tested, and test equipment specifications.

The proposal included a statistical treatment of the filter efficiency test results (U statistic). Thirty filter samples were to be tested for each certification application. The number of samples tested and the test statistic used in the treatment of the data was intended to provide a 95% confidence interval of 95% conformance (95% tolerance interval) of manufacturers' product to the certification criterion. These methods rely on the applicability of the "normal" or Gaussian distribution for test data. A similar statistical treatment of the test data was included in the 1987 NIOSH proposal.

A number of commenters expressed concern with the use of a NIOSH proposed U statistic (based on a 95% tolerance interval for the 95th percentile) to determine if the performance of filters submitted by manufacturers meet the requirements for requested classification (type). Comments concerned the use of the constant 2.22 for the calculation of the U statistic, suggesting that this is too strict a criterion for manufacturers to meet and implying that 95% tolerance intervals based on some lower percentile (e.g., 90th) would be more appropriate. Other comments concerned the distribution assumptions inherent in the calculation of the U statistic. Commenters expressed concern that the assumption that test data represent a sample from a Gaussian distribution is

incorrect and that the application of tolerance interval methods for this data is inappropriate.

Other commenters questioned NIOSH's justification to "knowingly" allow the certification of respirators that do not meet the performance requirements. They interpreted the statistical criterion as NIOSH accepting up to 5% of the distributed respirators to be less than the stated class minimum. This analysis of the data would imply that some of the distributed certified respirators perform below the inferred minimum performance level of its class. The commenters expressed concern that this would cause an unacceptably large number of workers to have inadequate respirator protection.

One commenter pointed out that the use of the U statistic was an attempt to predict future production variability. This commenter further asserted that respirators submitted for certification testing do not constitute a random sample of a manufacturer's product. Production variability, this commenter continued, is to be controlled by the separate quality control program.

NIOSH concurs with the commenter that the proposed statistical approach addressing pre-market production samples is inconsistent with determining product quality in a controlled process. NIOSH further agrees that the samples submitted for certification testing are not random samples. Therefore, the final rule does not include an acceptance criterion based upon the statistical treatment of test data.

A significant portion of the cost attributed to the proposed regulations (25 to 30% of the cost, by one estimate) resulted from the statistical treatment of data. Manufacturers stated that this cost impact would be reduced if a 95% tolerance interval based on a 90th percentile (i.e., 95% confidence of 90% conformance) were used. Manufacturers and others suggested that a pass/fail criterion should be offered. Several commenters suggested reducing the number of test samples and using a pass/fail criterion.

A pass/fail criterion is consistent with the current respirator acceptance criterion, and is generally accepted as appropriate for a certification program with testing of pre-production units. The pass/fail criterion presents another advantage in that it establishes the minimum acceptable performance level consistent with the class definition. A member of a 95% class will not be in compliance with the certification if it has an efficiency below that level when tested. The statistical test criterion

could allow some individual units to have performance test measurements below 95% but still meet certification requirements.

Based on these comments, NIOSH has reconsidered the use of the tolerance interval approach for the analysis of respirator performance data. NIOSH agrees that the application of the tolerance interval approach is inconsistent with type approval and recognizes that respirators submitted for certification do not constitute a random sample of a manufacturer's product. Consequently, the final rule has been modified to test 20 respirators for laboratory performance, with certification if all 20 units meet the specifications.

The proposal specified both sodium chloride (NaCl) as the solid test aerosol and dioctyl phthalate (DOP) as the liquid test aerosol. Although DOP is a suspected carcinogen, the set up of the test instruments precludes laboratory personnel exposure to the aerosol. Sodium chloride does not pose a suspected health hazard. Dioctyl phthalate is the most severe liquid, or degrading test aerosol known. It has been used for decades as the test aerosol for certification of the best (HEPA) part 11 filters. Sodium chloride is a solid test aerosol that provides some degrading characteristics. Sodium chloride has also been used for years as the solid test agent in the European (CEN) certification standards.

No comments were received against the use of NaCl as the solid test aerosol for non-powered respirators. One commenter, a former employee of the Department of Defense, questioned its use because the military does not use it in their mask testing. Another commenter, accepting the use of NaCl, stated that part 84 should allow equivalent test aerosols as well. The only negative comments received to the NaCl test aerosol were due to the difficulties associated with the testing of powered air-purifying respirators (PAPRs). The requirements for PAPRs was discussed previously in V. Discussion of Final Rule, B. Powered Air-Purifying Particulate Respirators.

Commenters interested in the use of certified respirators for protection against TB suggested the use of biological agents (bioaerosols) for the certification testing. It is not necessary to subject filter respirators to a bioaerosol as a condition of certification. By using test aerosols of the most penetrating size range, the efficiency-level determination of the certification testing will be the lowest obtainable for any size aerosol. Therefore, the efficiency level against



any bioaerosol for any certified respirator will meet or exceed the certified efficiency level.

Comments concerning the choice of liquid test aerosols were varied. Several different test agents were suggested including paraffin oil, Emery 3004, and hydrofluoric acid. Paraffin oil was suggested because it is consistent with the European (CEN) standards. The U.S. military has adopted Emery 3004 as a DOP replacement in instantaneous testing of filter efficiency. A commenter suggested that because hydrofluoric acid aerosol is common in many industries, it would be a more realistic test agent.

Each of the suggested alternative liquid aerosols would provide essentially the same initial or lightly loaded filter efficiency levels. The initial efficiency level of a filter is defined primarily by the particle size of the aerosol, not its degrading ability. The CEN standards use paraffin oil as the liquid test aerosol, but the filters are not loaded to a significant level. Emery 3004 has been adopted as a replacement for DOP by the military in initial efficiency testing as performed for the part 11 HEPA filters. Unlike DOP, none of the recommended alternative test aerosols provide severe degrading effects of the filters. This severity is an integral part of the part 84 testing, and addressing the uncertainties of the effects of actual workplace aerosols.

In considering these options, NIOSH is aware that no single test agent is used by every prominent standard-setting agency or organization. The CEN standard uses NaCl as a solid test aerosol. The current draft for revising the ANSI Z88.8 standard proposes NaCl and DOP as the test aerosols. No choice of test aerosol would provide consistency with all other standards, as sought by commenters. A fundamental purpose of the new testing standards is to assure that at least one class of filters is highly resistant to degradation by workplace aerosols. The DOP aerosol was selected for this purpose specifically because of its severe effect on filter efficiency level. The proposed alternatives demonstrate less severe effects on the filter media; therefore, they have been considered inappropriate for the evaluation intended by NIOSH.

The generation method of dioctyl phthalate aerosol was a concern to many commenters. Commenters questioned the particle size distribution for this test aerosol specified in the proposal being greater than that specified in the existing part 11 requirements. Commenters also questioned differences in test results based on the use of thermally generated (hot) or cold-

nebulized DOP aerosol. Although the proposal did not specify any aerosol generation technique to be used for DOP testing, much of NIOSH's research used as a basis for the proposal was performed with cold-nebulized DOP and NIOSH testing has demonstrated that correlation in results obtained between the two aerosol generation techniques is possible. Some commenters believed that the DOP aerosol generation method must be specified to ensure reproducible test results. These commenters used data from Industrial Safety Equipment Association-sponsored "round robin" testing of mechanical and electrostatic filter material. Complete data and specifics of the round robin testing were not provided to NIOSH. These tests were conducted among the majority of the air-purifying respirator manufacturers that are ISEA members. The test results indicated excellent correlation between the two aerosol generation methods for efficiency of standardized mechanical filter media. For standardized electrostatic media, a divergence in efficiency with increased filter loading was reported between the two aerosol generation methods. These commenters also reported that both the initial and stabilized efficiencies of the electrostatic media correlated well between the two aerosol generation methods. The divergence reported appears to be a different degradation rate between the two aerosols.

Moreover, several of the participants provided some additional insights into the circumstances of the testing. A significant portion of the manufacturers had recently acquired the cold-nebulized test instruments. The reproducibility problems reported, they admitted, could have resulted from operator inexperience. One of the participants with extensive experience with both aerosol generation methods related some of the experience gained by that manufacturer. Excellent correlation is maintained between this commenter's numerous cold-nebulized DOP instruments in use world-wide. Also, the commenter reported having encountered no reproducibility problems between thermally-generated and cold-nebulized instruments in testing electrostatic media when new DOP is used.

In NIOSH testing, some tests have provided good correlation of results between the two aerosol generation methods, while others have not. DOP changes chemically as it ages, becoming less pure. The thermal-generation method induces a similar chemical change, simulating accelerated aging of the DOP. Recent NIOSH testing

indicates that the chemically-changed DOP may cause the test instruments to fluctuate from the stated testing parameters. If monitored closely, and kept within the specified parameters, equivalent results are obtained with either aerosol generation method. Therefore, to accommodate these concerns, the final rule specifies a test using a neat cold-nebulized DOP test, or equivalent test. Allowing equivalent test methods permits the use of tests that respirator manufacturers may have already developed. As part of the established certification process, NIOSH evaluates the test results submitted by the applicant by comparing them to the results of NIOSH testing. Any test method yielding results equivalent to the NIOSH testing will be acceptable.

To further address the testing reproducibility concerns expressed by commenters, NIOSH is initiating a program whereby a standard mechanical and electrostatic filter media sample will be made available upon request for applicant correlation testing. NIOSH will run characterization tests on these standardized media and send a data sheet showing the test results with the samples. NIOSH has traditionally conducted correlation testing for applicants requesting such testing to document the agreement of their test instruments and procedures and those of NIOSH. This new procedure will continue the service provided to the applicants of assuring that the results they obtain on their instruments and with their procedures provide results comparable with NIOSH's certification tests. This new process will reduce the NIOSH resource requirements for corroborating the test results of the large number of applicants that NIOSH anticipates will be requesting this service and expedite the correlation process.

Several comments were received on the humidity preconditioning requirement for filters. One commenter stated that the proposed preconditioning time (24 hours) was inadequate to have much of an effect on the performance of electrostatic filter media. The commenter suggested a thirty-day preconditioning period. Information provided regarding the ISEA round-robin testing stated that the effects of the preconditioning were insignificant when testing with the DOP aerosol. This assessment agrees with NIOSH testing experience. The other commenters had concerns that the proposal did not provide: detail regarding uniform preconditioning, the size of the container, the allowable time after conditioning at which filter media must be placed within the container and



the allowable time for the filter to remain within the container until tested.

The final rule has been modified to require only N-series filters be taken out of their packaging and humidity preconditioned prior to filter efficiency level testing at 85±5 percent relative humidity at 38±2.5 °C for 25±1 hours. The final rule states that following the preconditioning, the filters shall be sealed in a gas-tight container and tested within 10 hours. R- and P-series filters do not have to be preconditioned because they are tested against DOP which is much more severe than humidity in regard to reducing filter efficiency. The preconditioning requirement is retained for the N-series filters to address the effect of humidity on the filter's efficiency because the sodium chloride aerosol is less severe than DOP in reducing filter efficiency. The 10-hour limitation on storage of the filters before efficiency testing will eliminate the variability concerns.

The final rule has been modified to specify a scanning mobility particle sizer (SMPS) or equivalent, as recommended by commenters, to be consistent with the latest technology. One commenter suggested a flame photometer be allowed for measurement of sodium chloride. The same commenter also stated that other sizing devices such as the Tyndall Owl have been used for years and should be an acceptable measuring instrument. NIOSH is aware that other instrumentation can provide sizing information that can equate to the values specified in the rule. In specifying the particle size, it is important to identify the technology used in its determination. The differential mobility particle sizer (DMPS) was specified in the proposed rule because this is the technology traditionally used by NIOSH to determine the particle sizes of this test. The use of these other instruments is acceptable and all other such equipment does not have to be specified in the final rule. To make size verification measurements manufacturers may use any particle sizing instrument that provides particle sizing information consistent with an SPMS.

**Subpart L—Chemical Cartridge Respirators**

*Section 84.203 Breathing Resistance Tests; Minimum Requirements*

This section is redesignated from existing § 11.162-1. This section is unmodified from the proposal.

It is modified only to delete reference to various classifications, such as paints and pneumoconiosis and fibrous

producing dusts, that are no longer appropriate with the introduction of the particulates classification with the new instantaneous-penetration test.

*Section 84.206 Particulate Tests; Respirators With Filters; Minimum Requirements; General*

This section is redesignated from existing § 11.162-7. This section is unmodified from the proposal. It is modified only to delete reference to various classifications, such as paints and pneumoconiosis and fibrous producing dusts, that are no longer appropriate with the introduction of the particulates classification with the new instantaneous-penetration test.

**Subpart KK—Dust, Fume, and Mist; Pesticide; Paint Spray Respirators and Combination Gas Masks**

This subpart has been added to continue the part 11 requirements for the existing dust, fume, and mist; pesticide; paint spray respirators and combination gas masks during the transition period to part 84.

These sections are derived from existing 30 CFR part 11, subpart K. They are modified to update them to part 84 section numbers.

This subpart also included the upgraded requirements for PAPRs to include only high efficiency filters (HEPA).

*Derivation Table*

The following derivation table lists (1) each section number of the final rule (New Section); and (2) the section number of the existing standard from which the proposed standard is derived (Old Section).

DERIVATION TABLE

New section	Old section
42 CFR	30 CFR
84.1 .....	11.1
84.2 .....	11.3
84.3 .....	11.4
84.4 .....	New.
84.10 .....	11.10
84.11 .....	11.11
84.12 .....	11.12
84.20 .....	11.20
84.21 .....	11.21
84.22 .....	11.22
84.30 .....	11.30
84.31 .....	11.31
84.32 .....	11.32
84.33 .....	11.33
84.34 .....	11.34
84.35 .....	11.35
84.36 .....	11.36
84.40 .....	11.40
84.41 .....	11.41
84.42 .....	11.42
84.43 .....	11.43

DERIVATION TABLE—Continued

New section	Old section
84.50 .....	11.50
84.51 .....	11.51
84.52 .....	11.52
84.53 .....	11.53
84.60 .....	11.60
84.61 .....	11.61
84.62 .....	11.62
84.63 .....	11.63
84.64 .....	11.64
84.65 .....	11.65
84.66 .....	11.66
84.70 .....	11.70
84.71 .....	11.71
84.72 .....	11.72
84.73 .....	11.73
84.74 .....	11.74
84.75 .....	11.75
84.76 .....	11.76
84.77 .....	11.77
84.78 .....	11.78
84.79 .....	11.79
84.80 .....	11.79-1
84.81 .....	11.80
84.82 .....	11.81
84.83 .....	11.82
84.84 .....	11.83
84.85 .....	11.84
84.86 .....	11.85-1
84.87 .....	11.85-2
84.88 .....	11.85-3
84.89 .....	11.85-4
84.90 .....	11.85-5
84.91 .....	11.85-6
84.92 .....	11.85-7
84.93 .....	11.85-8
84.94 .....	11.85-9
84.95 .....	11.85-10
84.96 .....	11.85-11
84.97 .....	11.85-12
84.98 .....	11.85-13
84.99 .....	11.85-14
84.100 .....	11.85-15
84.101 .....	11.85-16
84.102 .....	11.85-17
84.103 .....	11.85-18
84.104 .....	11.85-19
84.110 .....	11.90
84.111 .....	11.91
84.112 .....	11.92
84.113 .....	11.93
84.114 .....	11.94
84.115 .....	11.95
84.116 .....	11.96
84.117 .....	11.97
84.118 .....	11.98
84.119 .....	11.99
84.120 .....	11.100
84.121 .....	11.101
84.122 .....	11.102-1
84.123 .....	11.102-2
84.124 .....	11.102-3
84.125 .....	11.102-4
84.126 .....	11.102-5
84.130 .....	11.110
84.131 .....	11.111
84.132 .....	11.112
84.133 .....	11.113
84.134 .....	11.114
84.135 .....	11.115
84.136 .....	11.116
84.137 .....	11.117
84.138 .....	11.118



DERIVATION TABLE—Continued

DERIVATION TABLE—Continued

DISTRIBUTION TABLE—Continued

New section	Old section
84.139	11.119
84.140	11.120
84.141	11.121
84.142	11.122
84.143	11.123
84.144	11.124-1
84.145	11.124-2
84.146	11.124-3
84.147	11.124-4
84.148	11.124-5
84.149	11.124-6
84.150	11.124-7
84.151	11.124-8
84.152	11.124-9
84.153	11.124-10
84.154	11.124-11
84.155	11.124-12
84.156	11.124-13
84.157	11.124-14
84.158	11.124-15
84.159	11.124-16
84.160	11.124-17
84.161	11.124-18
84.162	11.124-19
84.163	11.124-20
84.170	11.130
84.171	11.131
84.172	11.132
84.173	11.133
84.174	11.134
84.175	11.135
84.176	11.136
84.177	11.137
84.178	11.138
84.179	New.
84.180	11.140-9
84.181	New.
84.182	11.140-10
84.190	11.150
84.191	11.151
84.192	11.152
84.193	11.153
84.194	11.154
84.195	11.155
84.196	11.156
84.197	11.157
84.198	11.158
84.199	11.158-1
84.200	11.159
84.201	11.160
84.202	11.161
84.203	11.162-1
84.204	11.162-2
84.205	11.162-3
84.206	11.162-7
84.207	11.162-8
84.250	11.200
84.251	11.201
84.252	11.202
84.253	11.203
84.254	11.204
84.255	11.205
84.256	11.206
84.257	11.207
84.258	11.208
84.1100	New.
84.1101	11.3
84.1102	11.20
84.1103	11.33
84.1130	11.102-4, 11.130, 11.170
84.1131	11.91, 11.131, 11.171

New section	Old section
84.1132	11.95, 11.132, 11.175
84.1133	11.96, 11.133, 11.176
84.1134	11.97, 11.134, 11.177
84.1135	11.98, 11.135, 11.178
84.1136	11.99, 11.136, 11.179
84.1137	11.100, 11.137, 11.180
84.1138	11.101, 11.138, 11.181
84.1139	11.139, 11.182
84.1140	11.140
84.1141	11.140-1
84.1142	11.140-2
84.1143	11.140-3
84.1144	11.140-4
84.1145	11.140-5
84.1146	11.140-6
84.1147	11.140-7
84.1148	11.140-8
84.1149	11.140-9
84.1150	11.140-10
84.1151	11.140-11
84.1152	11.140-12
84.1153	11.102-4
84.1154	11.172, 11.173
84.1155	11.174
84.1156	11.183, 11.183-1, 11.183-3, 11.183- 4, 11.183-5, 11.183-6, 11.183- 7
84.1157	11.162, 11.162-1, 11.162-4, 11.162- 5, 11.162-6, 11.162-8
84.1158	11.162-7

Old section	New section
11.35	84.35
11.36	84.36
11.40	84.40
11.41	84.41
11.42	84.42
11.43	84.43
11.50	84.50
11.51	84.51
11.52	84.52
11.53	84.53
11.60	84.60
11.61	84.61
11.62	84.62
11.63	84.63
11.64	84.64
11.65	84.65
11.66	84.66
11.70	84.70
11.71	84.71
11.72	84.72
11.73	84.73
11.74	84.74
11.75	84.75
11.76	84.76
11.77	84.77
11.78	84.78
11.79	84.79
11.79-1	84.80
11.80	84.81
11.81	84.82
11.82	84.83
11.83	84.84
11.84	84.85
11.85	Removed.
11.85-1	84.86
11.85-2	84.87
11.85-3	84.88
11.85-4	84.89
11.85-5	84.90
11.85-6	84.91
11.85-7	84.92
11.85-8	84.93
11.85-9	84.94
11.85-10	84.95
11.85-11	84.96
11.85-12	84.97
11.85-13	84.98
11.85-14	84.99
11.85-15	84.100
11.85-16	84.101
11.85-17	84.102
11.85-18	84.103
11.85-19	84.104
11.90	84.110
11.91	84.111, 84.1131
11.92	84.112
11.93	84.113
11.94	84.114
11.95	84.115, 84.1132
11.96	84.116, 84.1133
11.97	84.117, 84.1134
11.98	84.118, 84.1135
11.99	84.119, 84.1136
11.100	84.120, 84.1137
11.101	84.121, 84.1138
11.102	Removed.
11.102-1	84.122
11.102-2	84.123
11.102-3	84.124
11.102-4	84.125, 84.1130, 84.1153
11.102-5	84.126

Distribution Table

The following distribution table lists (1) the section number of the existing part 11 standard (Old Section); and (2) each section number of the final rule (New Section).

DISTRIBUTION TABLE

Old section	New section
30 CFR	42 CFR
11.1	84.1
11.2	Removed.
11.2-1	Removed.
11.3	84.2, 84.1101
11.4	84.3
11.10	84.10
11.11	84.11
11.12	84.12
11.20	84.20, 84.1102
11.21	84.21
11.22	84.22
11.30	84.30
11.31	84.31
11.32	84.32
11.33	84.33, 84.1103
11.34	84.34



DISTRIBUTION TABLE—Continued

Old section	New section
11.110	84.130
11.111	84.131
11.112	84.132
11.113	84.133
11.114	84.134
11.115	84.135
11.116	84.136
11.117	84.137
11.118	84.138
11.119	84.139
11.120	84.140
11.121	84.141
11.122	84.142
11.123	84.143
11.124	Removed.
11.124-1	84.144
11.124-2	84.145
11.124-3	84.146
11.124-4	84.147
11.124-5	84.148
11.124-6	84.149
11.124-7	84.150
11.124-8	84.151
11.124-9	84.152
11.124-10	84.153
11.124-11	84.154
11.124-12	84.155
11.124-13	84.156
11.124-14	84.157
11.124-15	84.158
11.124-16	84.159
11.124-17	84.160
11.124-18	84.161
11.124-19	84.162
11.124-20	84.163
11.124-21	Removed.
11.124-22	Removed.
11.124-23	Removed.
11.124-24	Removed.
11.130	84.170, 84.1130
11.131	84.171, 84.1131
11.132	84.172, 84.1132
11.133	84.173, 84.1133
11.134	84.174, 84.1134
11.135	84.175, 84.1135
11.136	84.176, 84.1136
11.137	84.177, 84.1137
11.138	84.178, 84.1138
11.139	84.1139
11.140	84.1140
11.140-1	84.1141
11.140-2	84.1142
11.140-3	84.1143
11.140-4	84.1144
11.140-5	84.1145
11.140-6	84.1146
11.140-7	84.1147
11.140-8	84.1148
11.140-9	84.180, 84.1149
11.140-10	84.182, 84.1150
11.140-11	84.1151
11.140-12	84.1152
11.150	84.190
11.151	84.191
11.152	84.192
11.153	84.193
11.154	84.194
11.155	84.195
11.156	84.196
11.157	84.197
11.158	84.198
11.158-1	84.199

DISTRIBUTION TABLE—Continued

Old section	New section
11.159	84.200
11.160	84.201
11.161	84.202
11.162	84.1157
11.162-1	84.203, 84.1157
11.162-2	84.204
11.162-3	84.205
11.162-4	84.1157
11.162-5	84.1157
11.162-6	84.1157
11.162-7	84.206, 84.1158
11.162-8	84.207, 84.1157
11.170	84.1130
11.171	84.1131
11.172	84.1154
11.173	84.1154
11.174	84.1155
11.175	84.1132
11.176	84.1133
11.177	84.1134
11.178	84.1135
11.179	84.1136
11.180	84.1137
11.181	84.1138
11.182	84.1139
11.183	84.1156
11.183-1	84.1156
11.183-2	Removed.
11.183-3	84.1156
11.183-4	84.1156
11.183-5	84.1156
11.183-6	84.1156
11.183-7	84.1156
11.200	84.250
11.201	84.251
11.202	84.252
11.203	84.253
11.204	84.254
11.205	84.255
11.206	84.256
11.207	84.257
11.208	84.258

### VII. Executive Order 12866 and Regulatory Flexibility Act

Section 1 of Executive Order 12866 requires that before promulgating a new regulation, an agency must weigh many competing factors. In particular, the agency must assess the need for the regulation, identify and assess alternatives, determine whether the regulation is designed to achieve the agency's objectives in the most cost-effective manner, and, to the extent feasible, use performance standards. In addition, Section 5 of the Order requires an assessment of the burden imposed by existing regulations, to identify those that have become unjustified or unnecessary as a result of changed circumstances. The Regulatory Flexibility Act (the Act) also requires that the agency periodically review existing regulations and consider reforming those that burden small entities, taking into account the degree to which technology or other factors have changed in the area affected by the

rule. NIOSH is promulgating these regulatory changes in compliance with both sections of the Executive Order and the Act.

Dose-response data are inadequate to permit a quantitative description of the risks that would be faced by American workers if respirators were not used. Neither are there dose-response data that can support a quantitative description of the risk reduction that will be achieved by the revised filter performance standards in 42 CFR part 84. Employers frequently lack the economic means or the technical expertise to make detailed workplace hazard assessments. For the great majority of occupational settings, environmental data on the airborne concentrations of toxic materials are completely lacking. When exposure data are available, they tend to be limited at best. Consequently, it is difficult to establish quantitative exposure-response relationships. Most often, occupational exposure data demonstrate the association between exposure and response, but do not support a precise exposure-response curve. Extrapolation from exposure to dose is subject to even greater uncertainty. The variability in exposure between and within workplaces, exposures over long working lifetimes, possibly inconsistent or improper use of respiratory protection, and undetected episodes of substandard respirator performance, among other factors, all make it very difficult to determine what a worker's dose may be even if there are measured exposure levels.

Employers, both large and small, rely upon respirators to protect their employees from airborne toxic contaminants. The preferred and most effective means of protecting workers is to prevent hazards entering their breathing zone in the first place, but it is not technologically or economically feasible in all instances to reduce airborne concentrations to safe levels. In those workplaces, respiratory protection is required to minimize workers' risks of acute and chronic health effects.

Although the incremental risk reduction associated with this rulemaking cannot be quantified, it is evident that increased filtering efficiency and enhanced filter reliability must increase the margin of safety for respirator users.

As the last, and occasionally the only, defense against some acute and chronic health hazards at work it is important that respirators be reliable and that they perform in the manner and to the extent the user and employer expect. If respirators fail to perform as expected, the user will be at greatly increased risk of suffering serious, sometimes fatal,



occupational disease or injury. In most circumstances the respirator user has no way of knowing if respirator performance is substandard. Except for the most acute responses to substandard respirator performance, it is not possible to attribute health effects to a failure of respiratory protection. Most of the serious occupational diseases have long latency periods, so respirator users typically would not know if they used an inferior device. Even the relationship to workplace exposures can be obscured because of the presumption that respirators provide effective protection.

Respirator purchasers and users expect and deserve to be able to select respirators with complete confidence that they will perform with a specific efficiency for a specific purpose. They rely on the NIOSH, formerly MSHA/NIOSH, performance standards and certification program to assure them that they can have that confidence.

These new particulate filter efficiency tests are needed to reduce potential health risks that may result from leakage of small particulates through some filters certified under the current regulations (30 CFR part 11). For over a decade the filter penetration tests contained in 30 CFR part 11 have been known to be deficient. Leakage of small aerosols has been recognized as a problem that could be corrected only by revising that regulation.

The magnitude of the filter leakage problem came into sharper focus in the early 1990's when NIOSH and other researchers used modern methods not available under the provisions of part 11 to measure performance over a range of particle sizes. For certain models, leakages higher than 50% were found. Not all respirator models exhibit this high level of leakage, but 30 CFR part 11 testing does not distinguish adequately from inadequate filters.

The respirator community acknowledges filter leakage to be a problem. The American National Standards Institute (ANSI) Z88.2-1992 national standard, for example, states that 2 of the 3 types of particulate respirators certified under 30 CFR part 11 should be used only when the workplace particulate contaminant is known to have a mass median aerodynamic diameter (MMAD) greater than 2 micrometer.

Compliance with aerosol size limitations such as those of the ANSI Z88.2 would represent a major technologic and economic burden for respirator users. Those burdens are great even for the largest employers and exceed the capacity of smaller employers. Adequate worker protection with DM and DFM respirators certified

under 30 CFR part 11 can be assured only if employers conduct sophisticated and expensive measurements of the size distribution of the aerosol in each workplace. This is simply too expensive for the great majority of respirator users, who may elect to use DM or DFM respirators without evaluating aerosols in their workplaces, thereby placing their workers at increased risk of occupational disease or disability. The only alternative at present is for those employers to provide costly high efficiency (HEPA) filters. The difficult and costly aerosol size measurements are not needed when HEPA filters are used because they are tested with the most penetrating size of aerosol. HEPA filters are therefore known to be effective against any aerosol regardless of size.

The new 42 CFR part 84 filter efficiency tests use only the most penetrating aerosol size, so all filters certified under these new procedures will be effective against any size aerosol. This new rule thereby corrects an acknowledged deficiency in existing filter efficiency tests, removes from the workplace respirators that fail to deliver the expected degree of worker protection, relieves employers of the need to perform costly and difficult measurements of aerosol size distribution, and provides alternatives to the expensive HEPA filters in workplaces where the aerosol size is either unknown or is known to be small.

This new rule continues to limit, as does the current 30 CFR part 11, the breathing resistance (inhalation and exhalation resistance) of the respirator. Breathing resistance is significant to respirator wearers in three ways. First, higher breathing resistance increases leakage at the face seal of the respirator. Face seal leakage is directly proportional to breathing resistance, other factors being equal. Second, respirators with lower breathing resistance are more comfortable and more acceptable to wearers. If a respirator is uncomfortable to wear, workers are less inclined to use their respirator as often as they should. Third, high breathing resistance can be an unacceptable physiological burden on some workers. For a worker with impaired pulmonary or cardiovascular function, high breathing resistance may make respirator use impossible. In this rule, NIOSH has increased the allowable inhalation and exhalation resistance in consideration of minimizing economic impact, but NIOSH has maintained the breathing resistance at a level that still will minimize adverse impacts on the respirator user.

E.O. 12866 further requires the agency to determine whether the proposed rule is "economically significant" (e.g., it does not have an annual effect on the economy of \$100 million). NIOSH generally prepares a regulatory flexibility analysis, in accordance with the Act, if the rule is expected to have a significant impact on a substantial number of small entities. NIOSH does not believe that this final rule will have an annual impact on the economy of \$100 million, nor does NIOSH believe that the rule will have a significant impact on a substantial number of small firms.

This regulatory change affects only particulate respirators. A total of 56 manufacturers hold respirator approvals, and 33 of these hold approvals for particulate respirators. Based on inquiries received, NIOSH believes that several additional manufacturers are planning to submit applications for particulate filter products under this new regulation.

Data are not available to define company size, market share, or diversity of products for the current approval-holders. Projections of impact are based on an understanding of manufacturers—dependence on existing approved particulate respirators. Of the 33 manufacturers that have particulate filter approvals, 24 hold additional approvals for devices other than particulate respirators, and nine have only particulate filter approvals. One of these manufacturer holds approvals for DM, DFM and HEPA respirators, while the remaining eight each hold only a single particulate filter approval. Because all existing HEPA filters are expected to pass the new certification tests, it appears that only eight of 56 respirator manufacturers might be dependent upon particulate filter respirators possibly at risk of not passing the new certification tests without redesign. At least one of these eight manufacturers commented favorably on this proposed rule, indicating readiness to meet these new criteria.

Any manufacturer that cannot meet the new criteria immediately will have three years in which to develop new products or face removal from the approved respirator market. However, loss of approved respirator status does not prohibit sales of the devices as non-approved units. The non-approved respirator market appears to be very lucrative, with several of the larger manufacturers participating. Non-approved respirators are sold in many retail outlets including hardware, auto supply, and department stores. Consumers purchase these devices for use against nuisance dusts while



performing various home and hobby-related activities.

While some current respirator manufacturers may experience negative impacts, other manufacturers that are not now approval holders have indicated an intention to enter this market. The new rule thus will stimulate competition as new technologies are introduced and new markets are developed. Furthermore, this rule enhances the ability of domestic manufacturers to compete globally, especially in the European Community. NIOSH expects to see more new approval holders develop as a result of the new rule.

A high percentage of the respirator manufacturers are large corporations or subsidiaries and are international in nature, although several employ 100 or fewer persons. NIOSH does not have an estimate of the total number employed by the 33 manufacturers of particulate respirators. Neither does NIOSH have any indication of how many employees are engaged solely in the manufacture of particulate respirators. However, the respirator manufacturing industry in general is mature and stable. A 1982 survey of the industry performed for NIOSH covered 29 firms that were active at that time, the majority of which continue to manufacture respirators in 1995. Of these, 12 were subsidiaries of larger firms. Median total employment was 375. A large portion of these workers were believed to be engaged in activities unrelated to particulate respirator manufacturing. Sales figures indicated respirator sales ranged from less than 1% to 10-15% of total corporate sales.

NIOSH believes the industry profile remains basically the same it was in 1982. That is, respirators do not represent the primary source of sales income for any of the manufacturers that will be affected. Because respirators represent a low percentage of overall sales, the percentage of total employees involved in the manufacture of respirators is believed also to be low. Therefore, few employees are likely to be severely impacted by the new rule. Indeed, the increased competition and opening of markets expected to result from the rule may well enhance aggregate employment for both current and new approval holders.

Most employers rely on government standards to determine acceptable levels of respirator performance. It would be inefficient and unreasonably costly for each of millions of occasional purchasers of these inexpensive devices to independently attempt to determine which devices operate effectively to filter out submicron toxic particles.

This rule removes a regulatory impediment to the improved design of respirators by substituting a performance standard for an obsolete specifications standard. The practical effect of this will be to enable firms to substitute a more effective and efficient filter material in lower-cost respirators. Respirators already using high efficiency filters meeting 30 CFR part 11 requirements will not be affected by this proposal. These respirators will not require modification to be certified under this final rule, although the certification may not be at the new P100 efficiency level. Although the category of performance may be reduced from the previous HEPA rating, no design or development costs are associated with the certification of these products.

NIOSH received limited responses to its request for comments and data for projected estimates of cost for materials and labor for these improved respirators. Several respirator manufacturers referred to a survey conducted by their trade association as suggesting that costs of this module would exceed \$100 million, but specific cost estimates for this module were not provided. The trade association reported that their estimate was based largely on the surveyed manufacturers' projections of procuring new equipment, procuring new materials, plant retooling, and the like. The largest manufacturer of respirators did not project the same cost impact on its products, even though that manufacturer recommended changing the proposed rule to eliminate the least costly class of proposed respirators and to increase the severity of two testing parameters. Another manufacturer stated that the "projected increased user cost for disposables of 42 CFR part 84 would be between \$440 and \$990 million," based solely on impacts to that manufacturer's products. This manufacturer forecast that prices to end users would rise by 1.7- to 2.9-fold or 9- to 16-fold depending on filter type.

Very limited data were submitted in support of any of these estimates, but it appears that the large discrepancy between NIOSH and industry cost estimates are attributable to 3 principal factors:

(1) Cost estimates by industry included many capital investment costs rather than recurring annual costs, inclusion of which improperly inflated the annual cost projections.

(2) An erroneous assumption made by the manufacturer projecting the greatest cost impact. That manufacturer assumed that the proposed fit test would require all disposable respirators to have an elastomeric flange. Additional costs

attributed to consumer reaction to this assumption were:

- (a) expensive reusable elastomeric cartridge respirators replacing inexpensive disposable models, and
- (b) costly respirator maintenance and training programs associated with reusable respirators.

Neither NIOSH nor other manufacturers projected either of these as a consequence of the fit testing. In any event, the requirement for fit testing was eliminated from the final rule. That represents a cost saving in itself but this change also renders moot the question of elastomeric flanges for disposable respirators.

(3) Two additional elements of the proposed rule were identified as having significant cost impact: statistical evaluation of certification test results and limitations on inhalation/exhalation resistance. These were changed in the final rule to eliminate the statistical criterion and to adopt the inhalation/exhalation resistance levels requested by the manufacturers. As a result and as discussed below under specific topics, NIOSH does not believe that this rule will approach the \$100 million threshold. In fact, NIOSH believes that over time manufacturers' costs and prices to users will fall.

Commenters stated that the statistical treatment of test data as included in the proposal would "add greatly to the cost of filters and respirators." One commenter estimated that the added manufacturing and waste costs attributable to this provision would be 25-30% of the costs attributable to the proposal. According to the commenters, the replacement of the proposed statistical treatment of test data with the less stringent statistical treatment proposed by NIOSH in 1987 or a pass/fail criterion would remove the added cost implications of the proposed rule.

As discussed previously, NIOSH has replaced the proposed requirement for the statistical treatment of test data with the recommended pass-fail criterion. Twenty filters are to be tested, reduced from 30 to be required under the proposal. This change in the final rule, based on technical concerns discussed previously, will significantly reduce the cost implications of the final rule from the estimated costs of the proposal.

The fit test requirements proposed under §§ 84.181 and 84.182 were identified as another source of a significant portion of the costs attributed to the proposed rule. The increased costs resulted from the interpretation that the isoamyl acetate testing would necessitate elastomeric inner flanges to be added to all certified disposable respirators in all categories.



This interpretation led to two conclusions that increased the cost estimates. The first conclusion was that all disposable filter respirators would need to be redesigned to include a costly elastomeric facepiece. The estimated increased costs of disposable respirators led to the second conclusion that the currently inexpensive and widely used disposable particulate respirators would be replaced by costly reusable elastomeric cartridge masks. This increased use of reusable masks was estimated to increase users' costs of respirator maintenance and training programs not associated with disposable respirators. The costs associated with the use of an isoamyl acetate represented a substantial portion of the projected cost impact of the proposed rule.

As discussed earlier, NIOSH has reconsidered the proposed requirement for isoamyl acetate fit-testing of these respirators. Based on technical considerations, the isoamyl acetate tests have not been included in the final rule. NIOSH anticipates that currently accepted, fit-testing procedures will continue to be used to assure a proper respirator-to-face seal for each respirator user. Based on prior experience with currently certified disposable respirators using these procedures, no redesign of the facepiece seal of disposable respirators will be required as a result of this final rule. Therefore, the cost implications attributed to the isoamyl acetate fit tests are not applicable to this final rule.

It is our understanding that substituting better filter material will have negligible effects on the costs of filters, over the long run. The material costs may be slightly increased, but are relatively small compared to those estimates for statistical evaluation and fit testing. The costs associated with these latter two have been greatly reduced by the requirements in the final rule.

The demonstrated level of performance for filters will be substantially more effective. Instead of an efficiency rate of 95 percent for removing particles sized at 1 to 2 micrometers in diameter, they will demonstrate the ability to remove particles of less than 1 micrometer in diameter at a typical efficiency rate of 95 to 99.97 percent. The importance of this change will vary considerably from workplace setting to setting. However, in at least some settings the benefits will be considerable.

For example, the classes of particulate filter respirators certified under this rule will meet or exceed the recommendations for respiratory

protective devices used for M. tuberculosis. Of the currently NIOSH-certified respirators, only high-efficiency particulate air (HEPA) filters meet or exceed these recommendations. The certification to an enhanced performance level will create options for the choice of respirators that adhere to the recommendations at reduced expense. A disposable (one-time use) HEPA filter respirator generally sells for around \$7 to \$10 and replaceable respirators equipped with HEPA filters can cost \$20 or more, with replacement filters costing about \$5 each. Replacement non-HEPA filters cost about \$1 to \$2 each. Disposable non-HEPA filters cost about \$1 to \$8 each when purchased in bulk. Costs for a N95 filter are expected to be less than those of a current HEPA filter. Applications of new filter technologies and market competition is expected to generally have the impact of reducing the cost of the new respirators. At least one commenter has already indicated that the 95% efficiency level respirators will be priced not exceeding the cost of 30 CFR part 11 disposable DFM respirators, \$5 to \$8 each.

NIOSH would expect similar effects—both improved health and cost avoidance—in many other settings. NIOSH estimates that as many as seven million workers use respirators at some time each year. NIOSH estimates that employers annually purchase over 110 million disposable respirators.

There are approximately 35 manufacturers of these respiratory devices. Most of these already possess or have access to test equipment needed to perform the new filter tests. As is currently required under 30 CFR part 11, NIOSH will continue to require that applicants conduct or have conducted examinations, inspections, and tests of respirator performance at least equivalent to those set by the respirator certification tests. This is to assure that all necessary research and development is conducted by the applicant prior to submitting an application to the Federal Government for testing of the respirator by NIOSH. For those manufacturers that do not currently possess this capability, NIOSH estimates that the purchase of this equipment represents an investment of approximately \$60,000. Amortized over time, this would not represent a significant cost for most manufacturers.

Commenters indicated that the projected costs of new, updated test instruments for the filter efficiency testing contributed significantly to the costs reported to be attributable to the proposed rule. NIOSH agrees that if manufacturers opt to purchase newly

developed instruments, this represents a significant investment. As discussed previously, the filter efficiency tests of this final rule can be conducted using the instrumentation previously specified for the testing of high efficiency filters under 30 CFR part 11. Therefore, the purchase of new test instruments is not required for most manufacturers. Further, the purchase of test instruments represents a capital investment amortized over time, not an annual recurring cost.

Filter materials are currently available that can be substituted into present filter designs with minimal redesign (if any) to meet the performance requirements of the new tests. Some currently NIOSH-certified respirators have, when tested using the new standards, demonstrated acceptable performance. Therefore, little or no cost will be needed to develop suitable filtration materials or redesign existing devices. However, NIOSH does realize that additional development and redesign costs may be incurred to augment the presently available products. NIOSH specifically requested relevant data and comments on projected costs of redesign of respirators.

One commenter cited the cost of commercially available filter media to meet the proposed standards as dramatically increased over the present cost of the existing 30 CFR part 11 disposable dust/mist requirements. The cost of present dust/mist media was stated as between 60 cents and one dollar per square yard, whereas the cost of commercially available filter media to meet the proposed 42 CFR part 84 requirements is between 12 dollars and 17 dollars per square yard, depending on the type (A, B, or C), and whether it is for the "solids" or "liquid/solids" category. Two other commenters indicated the availability of prototype respirators and filters that could be marketed for little or no cost increase from existing dust/fume/mist respirators and filters.

Several comments were received stating that the combination of proposed initial inhalation and exhalation resistance limits and efficiency levels might require increasing the surface area of filters. It was asserted that an increase in filter surface area to meet these requirements would "increase substantially the raw material and manufacturing costs of respirator protection." For the technical reasons discussed previously, the initial inhalation and exhalation resistances have been increased in the final rule to the values recommended by these commenters. Adoption of these values will allow "latitude to develop filters at



a reasonable cost without compromising safety or comfort to the user," according to the comments.

In summary, NIOSH did not believe the proposed rule change was "economically significant" within the definition of E.O. 12866 based on the cost projections attributable to the proposal that were provided to NIOSH and those modifications incorporated into the final rule.

Notwithstanding these general conclusions, there may be some manufacturers that will find it financially difficult, or a poor investment, to meet the new standards. NIOSH expects such problems to result from free market competition rather than the specific standards of these final regulations. That is, most knowledgeable employers would purchase more cost-effective respirators voluntarily and force major changes in the market if the present regulatory barriers were removed.

#### List of Subjects in 42 CFR Part 84

Administrative practice and procedure, Incorporation by reference, Labeling, Mine safety and health, Occupational safety and health, Personal protective equipment, Reporting and recordkeeping requirements, Respirators.

Dated: April 14, 1995.

**Philip R. Lee,**

*Assistant Secretary for Health.*

Dated: April 14, 1995.

**Donna E. Shalala,**

*Secretary.*

For the reasons set out in the preamble, 42 CFR part 84 is added to read as follows:

### PART 84—APPROVAL OF RESPIRATORY PROTECTIVE DEVICES

#### Subpart A—General Provisions

Sec.

84.1 Purpose.

84.2 Definitions.

84.3 Respirators for mine rescue or other emergency use in mines.

#### Subpart B—Application for Approval

84.10 Application procedures.

84.11 Contents of application.

84.12 Delivery of respirators and components by applicant; requirements.

#### Subpart C—Fees

84.20 Examination, inspection, and testing of complete respirator assemblies; fees.

84.21 Examination, inspection, and testing of respirator components or subassemblies; fees.

84.22 Unlisted fees; additional fees; payment by applicant prior to approval.

#### Subpart D—Approval and Disapproval

84.30 Certificates of approval; scope of approval.

84.31 Certificates of approval; contents.

84.32 Notice of disapproval.

84.33 Approval labels and markings; approval of contents; use.

84.34 Revocation of certificates of approval.

84.35 Changes or modifications of approved respirators; issuance of modification of certificate of approval.

84.36 Delivery of changed or modified approved respirator.

#### Subpart E—Quality Control

84.40 Quality control plans; filing requirements.

84.41 Quality control plans; contents.

84.42 Proposed quality control plans; approval by the Institute.

84.43 Quality control records; review by the Institute; revocation of approval.

#### Subpart F—Classification of Approved Respirators; Scope of Approval; Atmospheric Hazards; Service Time

84.50 Types of respirators to be approved; scope of approval.

84.51 Entry and escape, or escape only; classification.

84.52 Respiratory hazards; classification.

84.53 Service time; classification.

#### Subpart G—General Construction and Performance Requirements

84.60 Construction and performance requirements; general.

84.61 General construction requirements.

84.62 Component parts; minimum requirements.

84.63 Test requirements; general.

84.64 Pretesting by applicant; approval of test methods.

84.65 Conduct of examinations, inspections, and tests by the Institute; assistance by applicant; observers; recorded data; public demonstrations.

84.66 Withdrawal of applications; refund of fees.

#### Subpart H—Self-Contained Breathing Apparatus

84.70 Self-contained breathing apparatus; description.

84.71 Self-contained breathing apparatus; required components.

84.72 Breathing tubes; minimum requirements.

84.73 Harnesses; installation and construction; minimum requirements.

84.74 Apparatus containers; minimum requirements.

84.75 Half-mask facepieces, full facepieces, mouthpieces; fit; minimum requirements.

84.76 Facepieces; eyepieces; minimum requirements.

84.77 Inhalation and exhalation valves; minimum requirements.

84.78 Head harnesses; minimum requirements.

84.79 Breathing gas; minimum requirements.

84.80 Interchangeability of oxygen and air prohibited.

84.81 Compressed breathing gas and liquefied breathing gas containers; minimum requirements.

84.82 Gas pressure gages; minimum requirements.

84.83 Timers; elapsed time indicators; remaining service life indicators; minimum requirements.

84.84 Hand-operated valves; minimum requirements.

84.85 Breathing bags; minimum requirements.

84.86 Component parts exposed to oxygen pressures; minimum requirements.

84.87 Compressed gas filters; minimum requirements.

84.88 Breathing-bag test.

84.89 Weight requirement.

84.90 Breathing resistance test; inhalation.

84.91 Breathing resistance test; exhalation.

84.92 Exhalation valve leakage test.

84.93 Gas flow test; open circuit apparatus.

84.94 Gas flow test; closed circuit apparatus.

84.95 Service-time test; open circuit apparatus.

84.96 Service-time test; closed circuit apparatus.

84.97 Test for carbon dioxide in inspired gas; open- and closed-circuit apparatus; maximum allowable limits.

84.98 Tests during low temperature operation.

84.99 Man tests; testing conditions; general requirements.

84.100 Man tests 1, 2, 3, and 4; requirements.

84.101 Man test 5; requirements.

84.102 Man test 6; requirements.

84.103 Man tests; performance requirements.

84.104 Gas tightness test; minimum requirements.

#### Tables to Subpart H of Part 84

##### Subpart I—Gas Masks

84.110 Gas masks; description.

84.111 Gas masks; required components.

84.112 Canisters and cartridges in parallel; resistance requirements.

84.113 Canisters and cartridges; color and markings; requirements.

84.114 Filters used with canisters and cartridges; location; replacement.

84.115 Breathing tubes; minimum requirements.

84.116 Harnesses; installation and construction; minimum requirements.

84.117 Gas mask containers; minimum requirements.

84.118 Half-mask facepieces, full facepieces, and mouthpieces; fit; minimum requirements.

84.119 Facepieces; eyepieces; minimum requirements.

84.120 Inhalation and exhalation valves; minimum requirements.

84.121 Head harnesses; minimum requirements.

84.122 Breathing resistance test; minimum requirements.

84.123 Exhalation valve leakage test.

84.124 Facepiece tests; minimum requirements.



- 84.125 Particulate tests; canisters containing particulate filters; minimum requirements.
- 84.126 Canister bench tests; minimum requirements.

#### Tables to Subpart I of Part 84

##### Subpart J—Supplied-Air Respirators

- 84.130 Supplied-air respirators; description.
- 84.131 Supplied-air respirators; required components.
- 84.132 Breathing tubes; minimum requirements.
- 84.133 Harnesses; installation and construction; minimum requirements.
- 84.134 Respirator containers; minimum requirements.
- 84.135 Half-mask facepieces, full facepieces, hoods, and helmets; fit; minimum requirements.
- 84.136 Facepieces, hoods, and helmets; eyepieces; minimum requirements.
- 84.137 Inhalation and exhalation valves; check valves; minimum requirements.
- 84.138 Head harnesses; minimum requirements.
- 84.139 Head and neck protection; supplied-air respirators; minimum requirements.
- 84.140 Air velocity and noise levels; hoods and helmets; minimum requirements.
- 84.141 Breathing gas; minimum requirements.
- 84.142 Air supply source; hand-operated or motor driven air blowers; Type A supplied-air respirators; minimum requirements.
- 84.143 Terminal fittings or chambers; Type B supplied-air respirators; minimum requirements.
- 84.144 Hand-operated blower test; minimum requirements.
- 84.145 Motor-operated blower test; minimum requirements.
- 84.146 Method of measuring the power and torque required to operate blowers.
- 84.147 Type B supplied-air respirator; minimum requirements.
- 84.148 Type C supplied-air respirator, continuous-flow class; minimum requirements.
- 84.149 Type C supplied-air respirator, demand and pressure demand class; minimum requirements.
- 84.150 Air-supply line tests; minimum requirements.
- 84.151 Harness test; minimum requirements.
- 84.152 Breathing tube test; minimum requirements.
- 84.153 Airflow resistance test, Type A and Type AE supplied-air respirators; minimum requirements.
- 84.154 Airflow resistance test; Type B and Type BE supplied-air respirators; minimum requirements.
- 84.155 Airflow resistance test; Type C supplied-air respirator, continuous flow class and Type CE supplied-air respirator; minimum requirements.
- 84.156 Airflow resistance test; Type C supplied-air respirator, demand class; minimum requirements.
- 84.157 Airflow resistance test; Type C supplied-air respirator, pressure-demand class; minimum requirements.

- 84.158 Exhalation valve leakage test.
- 84.159 Man tests for gases and vapors; supplied-air respirators; general performance requirements.
- 84.160 Man tests for gases and vapors; Type A and Type AE respirators; test requirements.
- 84.161 Man tests for gases and vapors; Type B and Type BE respirators; test requirements.
- 84.162 Man test for gases and vapors; Type C respirators, continuous-flow class and Type CE supplied-air respirators; test requirements.
- 84.163 Man test for gases and vapors; Type C supplied-air respirators, demand and pressure-demand classes; test requirements.

#### Tables to Subpart J of Part 84

##### Subpart K—Non-Powered Air-Purifying Particulate Respirators

- 84.170 Non-powered air-purifying particulate respirators; description.
- 84.171 Non-powered air-purifying particulate respirators; required components.
- 84.172 Breathing tubes; minimum requirements.
- 84.173 Harnesses; installation and construction; minimum requirements.
- 84.174 Respirator containers; minimum requirements.
- 84.175 Half-mask facepieces, full facepieces, hoods, helmets, and mouthpieces; fit; minimum requirements.
- 84.176 Facepieces, hoods, and helmets; eyepieces; minimum requirements.
- 84.177 Inhalation and exhalation valves; minimum requirements.
- 84.178 Head harnesses; minimum requirements.
- 84.179 Non-powered air-purifying particulate respirators; filter identification.
- 84.180 Airflow resistance tests.
- 84.181 Non-powered air-purifying particulate filter efficiency level determination.
- 84.182 Exhalation valve leakage test; minimum requirements.

##### Subpart L—Chemical Cartridge Respirators

- 84.190 Chemical cartridge respirators; description.
- 84.191 Chemical cartridge respirators; required components.
- 84.192 Cartridges in parallel; resistance requirements.
- 84.193 Cartridges; color and markings; requirements.
- 84.194 Filters used with chemical cartridges; location; replacement.
- 84.195 Breathing tubes; minimum requirements.
- 84.196 Harnesses; installation and construction; minimum requirements.
- 84.197 Respirator containers; minimum requirements.
- 84.198 Half-mask facepieces, full facepieces, mouthpieces, hoods, and helmets; fit; minimum requirements.
- 84.199 Facepieces, hoods, and helmets; eyepieces; minimum requirements.
- 84.200 Inhalation and exhalation valves; minimum requirements.

- 84.201 Head harnesses; minimum requirements.
- 84.202 Air velocity and noise levels; hoods and helmets; minimum requirements.
- 84.203 Breathing resistance test; minimum requirements.
- 84.204 Exhalation valve leakage test; minimum requirements.
- 84.205 Facepiece test; minimum requirements.
- 84.206 Particulate tests; respirators with filters; minimum requirements; general.
- 84.207 Bench tests; gas and vapor tests; minimum requirements; general.

#### Tables to Subpart L of Part 84

##### Subpart M—[Reserved]

##### Subpart N—Special Use Respirators

- 84.250 Vinyl chloride respirators; description.
- 84.251 Required components.
- 84.252 Gas masks; requirements and tests.
- 84.253 Chemical-cartridge respirators; requirements and tests.
- 84.254 Powered air-purifying respirators; requirements and tests.
- 84.255 Requirements for end-of-service-life indicator.
- 84.256 Quality control requirements.
- 84.257 Labeling requirements.
- 84.258 Fees.

#### Subparts O through JJ [Reserved]

##### Subpart KK—Dust, Fume, and Mist; Pesticide; Paint Spray; Powered Air-Purifying High Efficiency Respirators and Combination Gas Masks

- 84.1100 Scope and effective dates.
- 84.1101 Definitions.
- 84.1102 Examination, inspection and testing of complete respirator assemblies; fees.
- 84.1103 Approval labels and markings; approval of contents; use.
- 84.1130 Respirators; description.
- 84.1131 Respirators; required components.
- 84.1132 Breathing tubes; minimum requirements.
- 84.1133 Harnesses; installation and construction; minimum requirements.
- 84.1134 Respirator containers; minimum requirements.
- 84.1135 Half-mask facepieces, full facepieces, hoods, helmets, and mouthpieces; fit; minimum requirements.
- 84.1136 Facepieces, hoods, and helmets; eyepieces; minimum requirements.
- 84.1137 Inhalation and exhalation valves; minimum requirements.
- 84.1138 Head harnesses; minimum requirements.
- 84.1139 Air velocity and noise levels; hoods and helmets; minimum requirements.
- 84.1140 Dust, fume, and mist respirators; performance requirements; general.
- 84.1141 Isoamyl acetate tightness test; dust, fume, and mist respirators designed for respiratory protection against fumes of various metals having an air contamination level not less than 0.05 milligram per cubic meter; minimum requirements.



- 84.1142 Isoamyl acetate tightness test; respirators designed for respiratory protection against dusts, fumes, and mists having an air contamination level less than 0.05 milligram per cubic meter, or against radionuclides; minimum requirements.
- 84.1143 Dust, fume, and mist air-purifying filter tests; performance requirements; general.
- 84.1144 Silica dust test for dust, fume, and mist respirators; single-use or reusable filters; minimum requirements.
- 84.1145 Silica dust test; non-powered single-use dust respirators; minimum requirements.
- 84.1146 Lead fume test for dust, fume, and mist respirators; minimum requirements.
- 84.1147 Silica mist test for dust, fume, and mist respirators; minimum requirements.
- 84.1148 Tests for respirators designed for respiratory protection against more than one type of dispersoid; minimum requirements.
- 84.1149 Airflow resistance tests; all dust, fume, and mist respirators; minimum requirements.
- 84.1150 Exhalation valve leakage test; minimum requirements.
- 84.1151 DOP filter test; respirators designed as respiratory protection against dusts, fumes, and mists having an air contamination level less than 0.05 milligram per cubic meter and against radionuclides; minimum requirements.
- 84.1152 Silica dust loading test; respirators designed as protection against dusts, fumes, and mists having an air contamination level less than 0.05 milligram per cubic meter and against radionuclides; minimum requirements.
- 84.1153 Dust, fume, mist, and smoke tests; canister bench tests; gas mask canisters containing filters; minimum requirements.
- 84.1154 Canister and cartridge requirements.
- 84.1155 Filters used with canisters and cartridges; location; replacement.
- 84.1156 Pesticide respirators; performance requirements; general.
- 84.1157 Chemical cartridge respirators with particulate filters; performance requirements; general.
- 84.1158 Dust, fume, and mist tests; respirators with filters; minimum requirements; general.

#### Tables to Subpart KK of Part 84

Authority: 29 U.S.C. 577a, 651 et seq., and 657(g); 30 U.S.C. 3, 5, 7, 811, 842(h), 844.

#### Subpart A—General Provisions

##### § 84.1 Purpose.

The purpose of the regulations contained in this part 84 is:

(a) To establish procedures and prescribe requirements which must be met in filing applications for approval by the National Institute for Occupational Safety and Health of respirators or changes or modifications of approved respirators;

(b) To establish a schedule of fees to be charged each applicant for the inspections, examinations, and testing conducted by the Institute under the provisions of this part;

(c) To provide for the issuance of certificates of approval or modifications of certificates of approval for respirators which have met the applicable construction, performance, and respiratory protection requirements set forth in this part; and

(d) To specify minimum requirements and to prescribe methods to be employed by the Institute and by the applicant in conducting inspections, examinations, and tests to determine the effectiveness of respirators used during entry into or escape from hazardous atmospheres.

##### § 84.2 Definitions.

As used in this part—

(a) *Applicant* means an individual, partnership, company, corporation, association, or other organization that designs, manufactures, assembles, or controls the assembly of a respirator and who seeks to obtain a certificate of approval for such respirator.

(b) *Approval* means a certificate or formal document issued by the Institute stating that an individual respirator or combination of respirators has met the minimum requirements of this part, and that the applicant is authorized to use and attach an approval label to any respirator, respirator container, or instruction card for any respirator manufactured or assembled in conformance with the plans and specifications upon which the approval was based, as evidence of such approval.

(c) *Approved* means conforming to the minimum requirements of this part.

(d) *Auxiliary equipment* means a self-contained breathing apparatus, the use of which is limited in underground mine rescue and recovery operations to situations where the wearer has ready access to fresh air and at least one crew equipped with approved self-contained breathing apparatus of 2 hours or longer rating, is in reserve at a fresh-air base.

(e) *Certification and Quality Assurance Branch* means the Certification and Quality Assurance Branch, Division of Safety Research, Appalachian Laboratory for Occupational Safety and Health, National Institute for Occupational Safety and Health, 1095 Willowdale Road, Morgantown, West Virginia 26505-2888.

(f) *Compressed-breathing gas* means oxygen or air stored in a compressed state and supplied to the wearer in gaseous form.

(g) *dBA* means sound pressure levels in decibels, as measured with the A-weighted network of a standard sound level meter using slow response.

(h) *Dust* means a solid mechanically produced particle with a size ranging from submicroscopic to macroscopic.

(i) *Respirators for entry into and escape from* means respiratory devices providing protection during entry into and escape from hazardous atmospheres.

(j) *Respirators for escape only* means respiratory devices providing protection only during escape from hazardous atmospheres.

(k) A *facepiece* or *mouthpiece* is a respirator component designed to provide a gas-tight or dust-tight fit with the face and may include headbands, valves, and connections for canisters, cartridges, filters, or respirable gas source.

(l) *Final inspection* means that activity carried out on a product after all manufacturing and assembly operations are completed to insure completeness and adherence to performance or other specifications, including satisfactory appearance.

(m) *Fume* means a solid condensation particle, generally less than 1 micrometer in diameter.

(n) *Gas* means an aeriform fluid which is in a gaseous state at ordinary temperature and pressure.

(o) *Hazardous atmosphere* means:

(1) Any atmosphere containing a toxic or disease producing gas, vapor, dust, fume, mist, or pesticide, either immediately or not immediately dangerous to life or health; or

(2) Any oxygen-deficient atmosphere.

(p) A *hood* or *helmet* is a respirator component which covers the wearer's head and neck, or head, neck, and shoulders, and is supplied with incoming respirable air for the wearer to breathe. It may include a headharness and connection for a breathing tube.

(q) *Immediately dangerous to life or health* means conditions that pose an immediate threat to life or health or conditions that pose an immediate threat of severe exposure to contaminants, such as radioactive materials, which are likely to have adverse cumulative or delayed effects on health.

(r) *Incoming inspection* means the activity of receiving, examining, and accepting only those materials and parts whose quality conforms to specification requirements.

(s) *In-process inspection* means the control of products at the source of production and at each step of the manufacturing process, so that departures from specifications can be



corrected before defective components or materials are assembled into the finished product.

(t) *Institute* means the National Institute for Occupational Safety and Health, Department of Health and Human Services.

(u) *Liquefied-breathing gas* means oxygen or air stored in liquid form and supplied to the wearer in a gaseous form.

(v) *Mist* means a liquid condensation particle with a size ranging from submicroscopic to macroscopic.

(w) *MSHA* means the Mine Safety and Health Administration, U.S. Department of Labor.

(x) *Not immediately dangerous to life or health* means any hazardous atmosphere which may produce physical discomfort immediately, chronic poisoning after repeated exposure, or acute adverse physiological symptoms after prolonged exposure.

(y) *Oxygen-deficient atmosphere* means an atmosphere which contains an oxygen partial pressure of less than 148 millimeters of mercury (19.5 percent by volume at sea level).

(z) *Powered air-purifying respirator* means a device equipped with a facepiece, hood, or helmet, breathing tube, canister, cartridge, filter, canister with filter, or cartridge with filter, and a blower.

(aa) *Respirator* means any device designed to provide the wearer with respiratory protection against inhalation of a hazardous atmosphere.

(bb) *Single-use respirator* means a respirator that is entirely discarded after excessive resistance, sorbent exhaustion, or physical damage renders it unsuitable for further use.

(cc) *Vapor* means the gaseous state of a substance that is solid or liquid at ordinary temperature and pressure.

#### § 84.3 Respirators for mine rescue or other emergency use in mines.

(a)(1) NIOSH and the Mine Safety and Health Administration (MSHA), U.S. Department of Labor, shall jointly review and issue certifications for respirators used for mine emergencies and mine rescue, including any associated service-life plans, users' manuals and other supporting documentation.

(2) Each certification for a respirator designed for mine rescue or other emergency use in mines shall include, as a condition of approval, any use limitations related to mine safety and health.

(b) NIOSH and MSHA shall jointly determine appropriate recall and retrofit remedies for field complaints or identified deficiencies involving any

respirators used in the mining environment.

### Subpart B—Application for Approval

#### § 84.10 Application procedures.

(a) Inspection, examination, and testing leading to the approval of the types of respirators classified in subpart F of this part shall be undertaken by the Institute only pursuant to written applications which meet the minimum requirements set forth in this subpart B.

(b) Applications shall be submitted to the Certification and Quality Assurance Branch, and shall be accompanied by a check, bank draft, or money order in the amount specified in subpart C of this part, payable to the order of the National Institute for Occupational Safety and Health.

(c) Except as provided in § 84.64, the examination, inspection, and testing of all respirators shall be conducted by the Certification and Quality Assurance Branch.

(d) Applicants, manufacturers, or their representatives may visit or communicate with the Certification and Quality Assurance Branch in order to discuss the requirements for approval of any respirator or the proposed designs thereof. No charge shall be made for such consultation and no written report shall be issued to applicants, manufacturers, or their representatives by the Institute as a result of such consultation.

(e) Respirators having electrical or electronic components that are required to be permissible under chapter I of title 30 shall be tested in accordance with 30 CFR part 18. Applications for approval of such respirators by MSHA shall be submitted in writing to: MSHA, Approval and Certification Center, Box 251, Industrial Park Road, Triadelphia, West Virginia 26059.

#### § 84.11 Contents of application.

(a) Each application for approval shall contain a complete written description of the respirator for which approval is requested together with drawings and specifications (and lists thereof) showing full details of construction of the respirator and of the materials used.

(b) Drawings shall be titled, numbered, and dated; any revision dates shall be shown on the drawings, and the purpose of each revision being sought shall be shown on the drawing or described on an attachment to the drawing to which it applies.

(c) Each application for approval shall contain a proposed plan for quality control which meets the minimum requirements set forth in subpart E of this part.

(d) Each application shall contain a statement that the respirator has been pretested by the applicant as prescribed in § 84.64, and shall include the results of such tests.

(e) Each application for approval shall contain a statement that the respirator and component parts submitted for approval are either prototypes, or made on regular production tooling, with no operation included which will not be incorporated in regular production processing.

(The information collections contained in this section are approved under OMB control number 0920-0109)

#### § 84.12 Delivery of respirators and components by applicant; requirements.

(a) Each applicant shall, when an application is filed pursuant to § 84.10, be advised by the Institute of the total number of respirators and component parts required for testing.

(b) The applicant shall deliver, at his own expense, the number of completely assembled respirators and component parts required for testing, to the Certification and Quality Assurance Branch.

(c) Respirators and component parts submitted for approval must be made from materials specified in the application.

(d) One completely assembled respirator approved under the provisions of this part may be retained by the Institute as a laboratory exhibit, the remaining respirators may be returned to the applicant at his own expense, upon written request within 30 days after notice of approval. If no such request is made, the respirators will be disposed of by the Institute in such manner as it deems appropriate.

(e) Where a respirator fails to meet the requirements for approval set forth in this part, all respirators and components delivered in accordance with this section may be returned to the applicant at his own expense, upon written request within 30 days after notice of disapproval. If no such request is made, the respirators will be disposed of by the Institute in such manner as it deems appropriate.

### Subpart C—Fees

#### § 84.20 Examination, inspection, and testing of complete respirator assemblies; fees.

Except as provided in § 84.22, the following fees shall be charged by the Institute for the examination, inspection and testing of complete respirator assemblies:

Self-contained breathing apparatus:  
Entry and escape, 1 hour or more \$3,500



Entry and escape, less than 1 hour .....	2,750
Escape only .....	2,000
Gas masks:	
Single hazard .....	1,100
Type N .....	4,100
Supplied-air respirators .....	750
Particulate respirators .....	1,250
Chemical cartridge respirators .....	1,150

**§ 84.21 Examination, inspection, and testing of respirator components or subassemblies; fees.**

Except as provided in § 84.22, the following fees shall be charged by the Institute for the examination, inspection and testing of the individual respirator components or subassemblies:

Facepieces .....	\$450
Canisters .....	900
Cartridges .....	600
Filters .....	650
Hoses .....	250
Blowers .....	250
Harnesses .....	100

**§ 84.22 Unlisted fees; additional fees; payment by applicant prior to approval.**

(a) Applications for the examination, inspection and testing of complete respirator assemblies which are not listed in § 84.20, or for the examination, inspection, and testing of respirator components or subassemblies which are not listed in § 84.21, shall be accompanied by the following deposits:

Complete respirator assembly .....	\$1,500
Each individual component or sub-assembly .....	500

(b) The Institute reserves the right to conduct any examination, inspection, or test it deems necessary to determine the quality and effectiveness of any listed or unlisted respirator assembly or respirator component or subassembly, and to assess the cost of such examinations, inspections, or tests against the applicant prior to the issuance of any approval for such assembly, component, or subassembly.

(c) The fees charged for the examination, inspection, and testing of unlisted respirator assemblies, unlisted individual respirator components or subassemblies, and for the additional examination, inspection, and testing of listed respirator assemblies and components or subassemblies shall be at the rate of \$100 per day for each man-day required to be expended by the Institute.

(d) Upon completion of all examinations, inspections, and tests of unlisted respirator assemblies or components, or following the completion of any additional examination, inspections, or tests of listed assemblies, or components or subassemblies, including retesting

subsequent to disapproval, the Institute shall advise the applicant in writing of the total cost assessed and the additional amount, if any, which must be paid to the Institute as a condition of approval.

(e) In the event the amount assessed by the Institute for unlisted assemblies, or components or subassemblies is less than the amount of the deposit submitted in accordance with paragraph (a) of this section, the Institute shall refund the overpayment upon the issuance of any approval or notice of disapproval.

**Subpart D—Approval and Disapproval**

**§ 84.30 Certificates of approval; scope of approval.**

(a) The Institute shall issue certificates of approval pursuant to the provisions of this subpart only for individual, completely assembled respirators which have been examined, inspected, and tested, and which meet the minimum requirements set forth in subparts H through L of this part, as applicable.

(b) The Institute will not issue certificates of approval for any respirator component or for any respirator subassembly.

(c) The Institute shall not issue an informal notification of approval. However, if the application for approval, submitted in accordance with § 84.11, states that the submitted respirator and component parts are only prototypes, the Institute will examine, inspect, and test such respirator and component parts in accordance with the provisions of this part. If, upon completion of such examinations, inspections and tests, it is found that the prototype meets the minimum requirements set forth in this part, the Institute may inform the applicant, in writing, of the results of the examinations, inspections, and tests, and may require him to resubmit respirators and component parts made on regular production tooling, with no operations included which will not be incorporated in regular production processing, for further examination, inspection, and testing, prior to issuance of the certificate of approval.

(d) Applicants required to resubmit respirators and component parts made on regular production tooling, with no operation included which will not be incorporated in regular production processing, shall be charged fees in accordance with subpart C of this part.

**§ 84.31 Certificates of approval; contents.**

(a) The certificate of approval shall contain a classification and a

description of the respirator or combination of respirators for which it is issued, as provided in this part.

(b) The certificate of approval shall specifically set forth any restrictions or limitations on the respirator's use in hazardous atmospheres.

(c) Each certificate of approval shall be accompanied by the drawings and specifications (and lists thereof) submitted by the applicant in accordance with § 84.11. These drawings and specifications shall be referenced in the certificate of approval, and shall be maintained by the applicant. The drawings and specifications listed in each certificate of approval shall set forth in detail the design and construction requirements which shall be met by the applicant during commercial production of the respirator.

(d) Each certificate of approval shall be accompanied by a reproduction of the approval label design to be employed by the applicant with each approved respirator, as provided in § 84.33.

(e) No test data or specific laboratory findings will accompany any certificate of approval, however, the Institute will release pertinent test data and specific findings upon written request by the applicant, or as required by statute or regulation.

(f) Each certificate of approval shall also contain the approved quality control plan as specified in § 84.42.

**§ 84.32 Notice of disapproval.**

(a) If, upon the completion of the examinations, inspections, and tests required to be conducted in accordance with the provisions of this part, it is found that the respirator does not meet the minimum requirements set forth in this part, the Institute shall issue a written notice of disapproval to the applicant.

(b) Each notice of disapproval shall be accompanied by all pertinent data or findings with respect to the defects of the respirator for which approval was sought with a view to the possible correction of any such defects.

(c) The Institute shall not disclose, except to the applicant or as required by statute or regulation, any data, findings, or other information with respect to any respirator for which a notice of disapproval is issued.

**§ 84.33 Approval labels and markings; approval of contents; use.**

(a) Full-scale reproductions of approval labels and markings, and a sketch or description of the method of application and position on the harness, container, canister, cartridge, filter, or



other component, together with instructions for the use and maintenance of the respirator shall be submitted to the Institute for approval.

(b) Approval labels shall bear the emblem of the National Institute for Occupational Safety and Health and the seal of the Department of Health and Human Services, the applicant's name and address, an approval number

assigned by the Institute and, where appropriate, restrictions or limitations placed upon the use of the respirator by the Institute. The approval number assigned by the Institute shall be designated by the prefix TC and a serial number.

(c) The Institute shall, where necessary, notify the applicant when

additional labels, markings, or instructions will be required.

(d) Approval labels and markings shall only be used by the applicant to whom they were issued.

(e) Legible reproductions or abbreviated forms of the label approved by the Institute for use on each respirator shall be attached to or printed at the following locations:

Respirator type	Label type	Location
Self-contained breathing apparatus	Entire .....	Harness assembly and canister (where applicable).
Gas mask .....	Entire .....	Mask container and canister.
Supplied air respirator .....	.....do .....	Respirator container or instruction card.
Particulate respirator .....	.....do .....	Respirator container and filter container.
	Abbreviated .....	Filters.
Chemical-cartridge respirator .....	Entire .....	Respirator container, cartridge container, and filter containers (where applicable).
	Abbreviated .....	Cartridges and filters and filter containers.

(f) The use of any Institute approval label obligates the applicant to whom it is issued to maintain or cause to be maintained the approved quality control sampling schedule and the acceptable quality level for each characteristic tested, and to assure that it is manufactured according to the drawings and specifications upon which the certificate of approval is based.

(g) Each respirator, respirator component, and respirator container shall, as required by the Institute to assure quality control and proper use of the respirator, be labeled distinctly to show the name of the applicant, and the name and letters or numbers by which the respirator or respirator component is designated for trade purposes, and the lot number, serial number, or approximate date of manufacture.

**§ 84.34 Revocation of certificates of approval.**

The Institute reserves the right to revoke, for cause, any certificate of approval issued pursuant to the provisions of this part. Such causes include, but are not limited to, misuse of approval labels and markings, misleading advertising, and failure to maintain or cause to be maintained the quality control requirements of the certificate of approval.

**§ 84.35 Changes or modifications of approved respirators; issuance of modification of certificate of approval.**

(a) Each applicant may, if he desires to change any feature of an approved respirator, request a modification of the original certificate of approval issued by the Institute for such respirator by filing an application for such modification in accordance with the provisions of this section.

(b) Applications shall be submitted as for an original certificate of approval, with a request for a modification of the existing certificate to cover any proposed change.

(c) The application shall be accompanied by appropriate drawings and specifications, and by a proposed quality control plan which meets the requirements of subpart E of this part.

(d) The application for modification, together with the accompanying material, shall be examined by the Institute to determine whether testing will be required.

(e) The Institute shall inform the applicant of the fee required for any additional testing and the applicant will be charged for the actual cost of any examination, inspection, or test required, and such fees shall be submitted in accordance with the provisions of subpart C of this part.

(f) If the proposed change or modification meets the requirements of this part, a formal certificate of modification will be issued, accompanied, where necessary, by a list of new and revised drawings and specifications covering the change(s) and reproductions of revised approval labels.

(The information collections contained in this section are approved under OMB control number 0920-0109.)

**§ 84.36 Delivery of changed or modified approved respirator.**

An approved respirator for which a formal certificate of modification has been issued shall be delivered, with proper markings and containers, by the applicant to the Certification and Quality Assurance Branch, as soon as it is commercially produced.

**Subpart E—Quality Control**

**§ 84.40 Quality control plans; filing requirements.**

As a part of each application for approval or modification of approval submitted pursuant to this part, each applicant shall file with the Institute a proposed quality control plan which shall be designed to assure the quality of respiratory protection provided by the respirator for which approval is sought.

**§ 84.41 Quality control plans; contents.**

(a) Each quality control plan shall contain provisions for the management of quality, including:

(1) Requirements for the production of quality data and the use of quality control records;

(2) Control of engineering drawings, documentations, and changes;

(3) Control and calibration of measuring and test equipment;

(4) Control of purchased material to include incoming inspection;

(5) Lot identification, control of processes, manufacturing, fabrication, and assembly work conducted in the applicant's plant;

(6) Audit of final inspection of the completed product; and

(7) The organizational structure necessary to carry out these provisions.

(b) Each provision for incoming and final inspection in the quality control plan shall include a procedure for the selection of a sample of respirators and the components thereof for testing, in accordance with procedures set forth in Military Standard MIL-STD-414, 11 June 1957, including Change Notice No. 1, "Sampling Procedures and Tables for Inspection by Variables for Percent Defective," or an approved equivalent sampling procedure, or an approved



combination of sampling procedures. The procedure of Military Standard MIL-STD-105D, 29 April 1963, "Sampling Procedures and Tables for Inspection by Attributes," is an example of an equivalent sampling procedure. MIL-STD-414 is incorporated by reference and has been approved by the Director of the Federal Register in accordance with 5 U.S.C. 552(a) and 1 CFR part 51. Copies may be obtained from DODSSP, Standardization Document Order Desk, 700 Robbins Avenue, Bldg. 4D, Philadelphia, PA 19111-5094. Copies may be inspected at the NIOSH, Certification and Quality Assurance Branch, 1095 Willowdale Road, Morgantown, WV 26505-2888, or at the Office of the Federal Register, 800 North Capitol Street NW., suite 700, Washington, DC. Copies of MIL-STD-105D may be inspected or obtained from the NIOSH, Certification and Quality Assurance Branch, 1095 Willowdale Road, Morgantown, WV 26505-2888. Incoming bulk raw material inspection or verification of specification, and in-process inspection shall be sufficient to ensure control of product quality through the manufacturing cycle.

(c) The sampling procedure shall include a list of the characteristics to be tested by the applicant or his agent.

(d) The characteristics listed in accordance with paragraph (c) of this section shall be classified according to the potential effect of such defect and grouped into the following classes:

(1) *Critical*. A defect that judgment and experience indicate is likely to result in a condition immediately hazardous to life or health for individuals using or depending upon the respirator;

(2) *Major A*. A defect, other than critical, that is likely to result in failure to the degree that the respirator does not provide any respiratory protection, or a defect that reduces protection and is not detectable by the user;

(3) *Major B*. A defect, other than Major A or critical, that is likely to result in reduced respiratory protection, and is detectable by the user; and

(4) *Minor*. A defect that is not likely to materially reduce the usability of the respirator for its intended purpose, or a defect that is a departure from established standards and has little bearing on the effective use or operation of the respirator.

(e) The quality control inspection test method to be used by the applicant or his agent for each characteristic required to be tested shall be described in detail.

(f) Each item manufactured shall be 100 percent inspected for defects in all critical characteristics and all defective items shall be rejected.

(g) The Acceptable Quality Level (AQL) for each major or minor defect so classified by the applicant shall be:

- (1) *Major A*. 1.0 percent;
- (2) *Major B*. 2.5 percent; and
- (3) *Minor*. 4.0 percent.

(h) Except as provided in paragraph (i) of this section, inspection level IV as described in MIL-STD-414, 11 June 1957, including Change Notice No. 1, "Sampling Procedures and Tables for Inspection by Variables for Percent Defective," or an equivalent procedure, shall be used for major and minor characteristics and 100 percent inspection for critical characteristics. Inspection level II as described in MIL-STD-105D, 29 April 1963, "Sampling Procedures and Tables for Inspection by Attributes," is an example of an equivalent procedure.

(i) Subject to the approval of the Institute, where the quality control plan provisions for raw material, processes, manufacturing, and fabrication, inspections are adequate to ensure control of finished article quality, destructive testing of finished articles may be conducted at a lower level of inspection than that specified in paragraph (h) of this section.

(The information collections contained in this section are approved under OMB control number 0920-0109)

#### **§ 84.42 Proposed quality control plans; approval by the Institute.**

(a) Each proposed quality control plan submitted in accordance with this subpart shall be reviewed by the Institute to determine its effectiveness in ensuring the quality of respiratory protection provided by the respirator for which an approval is sought.

(b) If the Institute determines that the proposed quality control plan submitted by the applicant will not ensure adequate quality control, the Institute shall require the applicant to modify the procedures and testing requirements of the plan prior to approval of the plan and issuance of any certificate of approval.

(c) Approved quality control plans shall constitute a part of and be incorporated into any certificate of approval issued by the Institute, and compliance with such plans by the applicant shall be a condition of approval.

#### **§ 84.43 Quality control records; review by the Institute; revocation of approval.**

(a) The applicant shall keep quality control inspection records sufficient to carry out the procedures required in MIL-STD-414, 11 June 1957, including Change Notice No. 1, "Sampling Procedures and Tables for Inspection by

Variables for Percent Defective," or an approved equivalent sampling procedure. MIL-STD-105D, 29 April 1963, "Sampling Procedures and Tables for Inspection by Attributes," is an example of an approved equivalent sampling procedure. MIL-STD-414 is incorporated by reference and has been approved by the Director of the Federal Register in accordance with 5 U.S.C. 552(a) and 1 CFR part 51. Copies may be obtained from DODSSP, Standardization Document Order Desk, 700 Robbins Avenue, Bldg. 4D, Philadelphia, Pa. 19111-5094. Copies may be inspected at the NIOSH, Certification and Quality Assurance Branch, 1095 Willowdale Road, Morgantown, WV 26505-2888, or at the Office of the Federal Register, 800 North Capitol Street, NW., suite 700, Washington, DC. Copies of MIL-STD-105D may be inspected or obtained from the NIOSH, Certification and Quality Assurance Branch, 1095 Willowdale Road, Morgantown, WV 26505-2888.

(b) The Institute reserves the right to have its representatives inspect the applicant's quality control test methods, equipment, and records, and to interview any employee or agent of the applicant in regard to quality control test methods, equipment, and records.

(c) The Institute reserves the right to revoke, for cause, any certificate of approval where it is found that the applicant's quality control test methods, equipment, or records do not ensure effective quality control over the respirator for which the approval was issued.

(The information collections contained in this section are approved under OMB control number 0920-0109)

### **Subpart F—Classification of Approved Respirators; Scope of Approval; Atmospheric Hazards; Service Time**

#### **§ 84.50 Types of respirators to be approved; scope of approval.**

Approvals shall be issued for the types of respirators which have been classified pursuant to this subpart F, have been inspected, examined and tested by the Institute, in accordance with the provisions of subparts G through L of this part, and have been found to provide respiratory protection for fixed periods of time against the hazards specified in such approval.

#### **§ 84.51 Entry and escape, or escape only; classification.**

Respirators described in subparts H through L of this part shall be classified for use as follows:

(a) *Entry and escape*. Respirators designed and approved for use during



entry into a hazardous atmosphere, and for escape from a hazardous atmosphere; or

(b) *Escape only.* Respirators designed and approved for use only during escape from a hazardous atmosphere.

**§ 84.52 Respiratory hazards; classification.**

Respirators described in subparts H through L of this part shall be classified as approved for use against any or all of the following respiratory hazards:

- (a) Oxygen deficiency;
- (b) Gases and vapors; and
- (c) Particles, including dusts, fumes and mists.

**§ 84.53 Service time; classification.**

(a) Respirators described in subparts H through L of this part shall be classified, where applicable, as approved for use during the following prescribed service times:

- (1) Four hours;
- (2) Three hours;
- (3) Two hours;
- (4) One hour;
- (5) Forty-five minutes;
- (6) Thirty minutes;
- (7) Fifteen minutes;
- (8) Ten minutes;
- (9) Five minutes; or
- (10) Three minutes.

(b) Other service times may be prescribed by the Institute.

**Subpart G—General Construction and Performance Requirements**

**§ 84.60 Construction and performance requirements; general.**

(a) The Institute shall issue approvals for the types of respirators described in subparts H through L of this part which have met the minimum requirements set forth for such respirators in this part.

(b) In addition to the types of respirators specified in subparts H through L of this part, the Institute shall issue approvals for other respiratory protective devices not specifically described in this part subject to such additional requirements as may be imposed in accordance with § 84.63(c).

**§ 84.61 General construction requirements.**

(a) Respirators will not be accepted by the Institute for examination, inspection and testing unless they are designed on sound engineering and scientific principles, constructed of suitable materials and evidence good workmanship.

(b) Respirator components which come into contact with the wearer's skin shall be made of nonirritating materials.

(c) Components replaced during or after use shall be constructed of

materials which will not be damaged by normal handling.

(d) Mouthpieces, hoods, helmets, and facepieces, except those employed in single-use respirators, shall be constructed of materials which will withstand repeated disinfection as recommended by the applicant in his instructions for use of the device.

**§ 84.62 Component parts; minimum requirements.**

(a) The component parts of each respirator shall be:

(1) Designed, constructed, and fitted to insure against creation of any hazard to the wearer;

(2) Assembled to permit easy access for inspection and repair of functional parts; and

(3) Assembled to permit easy access to parts which require periodic cleaning and disinfecting.

(b) Replacement parts shall be designed and constructed to permit easy installation and to maintain the effectiveness of the respirator.

**§ 84.63 Test requirements; general.**

(a) Each respirator and respirator component shall when tested by the applicant and by the Institute, and meet the applicable requirements set forth in subparts H through L of this part.

(b) Where a combination respirator is assembled from two or more types of respirators, as described in this part, each of the individual respirator types which have been combined shall, as applicable, meet the minimum requirements for such respirators set forth in subparts H through L of this part, and such combination respirators, except as specified in § 84.70(b)(2), will be classified by the type of respirator in the combination which provides the least protection to the user.

(c) In addition to the minimum requirements set forth in subparts H through L of this part, the Institute reserves the right to require, as a further condition of approval, any additional requirements deemed necessary to establish the quality, effectiveness, and safety of any respirator used as protection against hazardous atmospheres.

(d) Where it is determined after receipt of an application that additional requirements will be required for approval, the Institute will notify the applicant in writing of these additional requirements, and necessary examinations, inspections, or tests, stating generally the reasons for such requirements, examinations, inspections, or tests.

**§ 84.64 Pretesting by applicant; approval of test methods.**

(a) Prior to making or filing any application for approval or modification of approval, the applicant shall conduct, or cause to be conducted, examinations, inspections, and tests of respirator performance which are equal to or exceed the severity of those prescribed in this part.

(b) With the application, the applicant shall provide a statement to the Institute showing the types and results of the examinations, inspections, and tests required under paragraph (a) of this section and state that the respirator meets the minimum requirements of subparts H through L of this part, as applicable. Complete examination, inspection, and test data shall be retained on file by the applicant and be submitted, upon request, to the Institute.

(c) The Institute may, upon written request by the applicant, provide drawings and descriptions of its test equipment and otherwise assist the applicant in establishing a test laboratory or securing the services of a testing agency.

(d) No approval will be issued until the Institute has validated the applicant's test results.

**§ 84.65 Conduct of examinations, inspections, and tests by the Institute; assistance by applicant; observers; recorded data; public demonstrations.**

(a) All examinations, inspections, and tests conducted pursuant to subparts H through L of this part will be under the sole direction and control of the Institute.

(b) The Institute may, as a condition of approval, require the assistance of the applicant or agents of the applicant during the assembly, disassembly, or preparation of any respirator or respirator component prior to testing or in the operation of such equipment during testing.

(c) Only Institute personnel, persons assisting the Institute pursuant to paragraph (b) of this section, and such other persons as are requested by the Institute or the applicant to be observers, shall be present during any examination, inspection, or test conducted prior to the issuance of an approval by the Institute for the equipment under consideration.

(d) The Institute shall hold as confidential any analyses, drawings, specifications, or materials submitted by the applicant and shall not disclose any principles or patentable features of such equipment, except as required by statute or regulation.

(e) As a condition of each approval issued for any respirator, the Institute



reserves the right, following the issuance of such approval, to conduct such public tests and demonstrations of the approved respiratory equipment as is deemed appropriate.

**§ 84.66 Withdrawal of applications; refund of fees.**

(a) Any applicant may, upon a written request submitted to the Institute, withdraw any application for approval of any respirator.

(b) Upon receipt of a written request for the withdrawal of an application, the Institute shall determine the total man-days expended and the amount due for services already performed during the course of any examinations, inspections, or tests conducted pursuant to such application. The total amount due shall be determined in accordance with the provisions of § 84.22 and assessed against the fees submitted by the applicant. If the total amount assessed is less than the fees submitted, the Institute shall refund the balance together with a statement of the charges made for services rendered.

**Subpart H—Self-Contained Breathing Apparatus**

**§ 84.70 Self-contained breathing apparatus; description.**

(a) Self-contained breathing apparatus, including all completely assembled, portable, self-contained devices designed for use as respiratory protection during entry into and escape from or escape only from hazardous atmospheres, are described as follows:

(1) *Closed-circuit apparatus.* An apparatus of the type in which the exhalation is rebreathed by the wearer after the carbon dioxide has been effectively removed and a suitable oxygen concentration restored from sources composed of:

- (i) Compressed oxygen; or
- (ii) Chemical oxygen; or
- (iii) Liquid-oxygen.

(2) *Open-circuit apparatus.* An apparatus of the following types from which exhalation is vented to the atmosphere and not rebreathed:

(i) *Demand-type apparatus.* An apparatus in which the pressure inside the facepiece in relation to the immediate environment is positive during exhalation and negative during inhalation; or

(ii) *Pressure-demand-type apparatus.* An apparatus in which the pressure inside the facepiece in relation to the immediate environment is positive during both inhalation and exhalation.

(b) The following respirators may be classified as designed and approved for use during emergency entry into a hazardous atmosphere:

(1) A combination respirator which includes a self-contained breathing apparatus; and

(2) A Type "C" or Type "CE" supplied air respirator, where—

(i) The self-contained breathing apparatus is classified for 3-, 5-, or 10-minute service time and the air line supply is used during entry; or

(ii) The self-contained breathing apparatus is classified for 15 minutes or longer service time and not more than 20 percent of the rated capacity of the air supply is used during entry.

(c) Self-contained breathing apparatus classified for less than 1 hour service time will not be approved for use during underground mine rescue and recovery operations except as auxiliary equipment.

(d) Self-contained breathing apparatus classified for less than 30 minutes' service time will not be approved for use as auxiliary equipment during underground mine rescue and recovery operations.

**§ 84.71 Self-contained breathing apparatus; required components.**

(a) Each self-contained breathing apparatus described in § 84.70 shall, where its design requires, contain the following component parts:

- (1) Facepiece or mouthpiece, and noseclip;
- (2) Respirable breathing gas container;
- (3) Supply of respirable breathing gas;
- (4) Gas pressure or liquid level gages;
- (5) Timer;
- (6) Remaining service life indicator or warning device;
- (7) Hand-operated valves;
- (8) Breathing bag;
- (9) Safety relief valve or safety relief system; and
- (10) Harness.

(b) The components of each self-contained breathing apparatus shall meet the minimum construction requirements set forth in subpart G of this part.

**§ 84.72 Breathing tubes; minimum requirements. Flexible breathing tubes used in conjunction with breathing apparatus shall be designed and constructed to prevent:**

- (a) Restriction of free head movement;
- (b) Disturbance of the fit of facepieces and mouthpieces;
- (c) Interference with the wearer's activities; and
- (d) Shutoff of airflow due to kinking, or from chin or arm pressure.

**§ 84.73 Harnesses; installation and construction; minimum requirements.**

(a) Each apparatus shall, where necessary, be equipped with a suitable harness designed and constructed to

hold the components of the apparatus in position against the wearer's body.

(b) Harnesses shall be designed and constructed to permit easy removal and replacement of apparatus parts and, where applicable, provide for holding a full facepiece in the ready position when not in use.

**§ 84.74 Apparatus containers; minimum requirements.**

(a) Apparatus may be equipped with a substantial, durable container bearing markings which show the applicant's name, the type and commercial designation of the respirator it contains, and all appropriate approval labels.

(b) Containers supplied by the applicant for carrying or storing self-contained breathing apparatus will be inspected, examined, and tested as components of the respirator for which approval is sought.

(c) Containers for self-contained breathing apparatus shall be designed and constructed to permit easy removal of the apparatus.

**§ 84.75 Half-mask facepieces, full facepieces, mouthpieces; fit; minimum requirements.**

(a) Half-mask facepieces and full facepieces shall be designed and constructed to fit persons with various facial shapes and sizes, either:

- (1) By providing more than one facepiece size; or
- (2) By providing one facepiece size which will fit varying facial shapes and sizes.

(b) Full facepieces shall provide for the optional use of corrective spectacles or lenses which shall not reduce the respiratory protective qualities of the apparatus.

(c) Apparatus with mouthpieces shall be equipped with noseclips which are securely attached to the mouthpiece or apparatus and provide an airtight seal.

(d) Facepieces shall be designed to prevent eyepiece, spectacle, and lens fogging.

**§ 84.76 Facepieces; eyepieces; minimum requirements.**

(a) Facepieces shall be designed and constructed to provide adequate vision which is not distorted by the eyepiece.

(b) All eyepieces shall be designed and constructed to be impact and penetration resistant. Federal Specification, Mask, Air Line: and Respirator, Air Filtering, Industrial, GGG-M-125d, October 11, 1965 with interim amendment-1, July 30, 1969, is an example of an appropriate standard for determining impact and penetration resistance. Copies of GGG-M-125d may be obtained from the NIOSH, Certification and Quality Assurance



Branch, 1095 Willowdale Road, Morgantown, WV 26505-2888.

**§ 84.77 Inhalation and exhalation valves; minimum requirements.**

(a) Inhalation and exhalation valves shall be provided where necessary and protected against damage and distortion.

(b) Exhalation valves shall be—

- (1) Protected against external influence; and
- (2) Designed and constructed to prevent inward leakage of contaminated air.

**§ 84.78 Head harnesses; minimum requirements.**

(a) Facepieces shall be equipped with adjustable and replaceable head harnesses designed and constructed to provide adequate tension during suspension and an even distribution of pressure over the entire area in contact with the face.

(b) Mouthpieces shall be equipped, where applicable, with adjustable and replaceable harnesses designed and constructed to hold the mouthpiece in place.

**§ 84.79 Breathing gas; minimum requirements.**

(a) Breathing gas used to supply apparatus shall be respirable and contain no less than 19.5 (dry atmosphere) volume percent of oxygen.

(b) Oxygen, including liquid oxygen, shall contain not less than 99.0 percent, by volume, of pure O<sub>2</sub>, not more than 0.03%, by volume, carbon dioxide, and not more than 0.001%, by volume, carbon monoxide. Methods for making these determinations can be found in the U.S. Pharmacopeia National Formulary. Containers used for oxygen must not be treated with any toxic, sleep-inducing, narcosis-producing, or respiratory tract irritating compounds.

(c) Compressed, gaseous breathing air shall meet the applicable minimum grade requirements for Type I gaseous air set forth in the Compressed Gas Association Commodity Specification for Air, G-7.1, 1966 (Grade D or higher quality). G-7.1 is incorporated by reference and has been approved by the Director of the Federal Register in accordance with 5 U.S.C. 552(a) and 1 CFR part 51. Copies may be obtained from American National Standards Institute, Inc., 1430 Broadway, New York, NY 10018. Copies may be inspected at the NIOSH, Certification and Quality Assurance Branch, 1095 Willowdale Road, Morgantown, WV 26505-2888, or at the Office of the Federal Register, 800 North Capitol Street, NW., suite 700, Washington, DC.

(d) Compressed, liquefied breathing air shall meet the applicable minimum

grade requirements for Type II liquid air set forth in the Compressed Gas Association Commodity Specification for Air, G-7.1, 1966 (Grade B or higher quality). G-7.1 is incorporated by reference and has been approved by the Director of the Federal Register in accordance with 5 U.S.C. 552(a) and 1 CFR part 51. Copies may be obtained from American National Standards Institute, Inc., 1430 Broadway, New York, NY 10018. Copies may be inspected at the NIOSH, Certification and Quality Assurance Branch, 1095 Willowdale Road, Morgantown, WV 26505-2888, or at the Office of the Federal Register, 800 North Capitol Street, NW., suite 700, Washington, DC.

**§ 84.80 Interchangeability of oxygen and air prohibited.**

Approvals shall not be issued by the Institute for any apparatus, combination of respirator assemblies, or any apparatus or respirator component which is designed or constructed to permit the interchangeable use of oxygen and air.

**§ 84.81 Compressed breathing gas and liquefied breathing gas containers; minimum requirements.**

(a) Compressed breathing gas and liquefied breathing gas containers shall meet the minimum requirements of the Department of Transportation for interstate shipment of such containers when fully charged.

(b) Such containers shall be permanently and legibly marked to identify their contents, e.g., compressed breathing air, compressed breathing oxygen, liquefied breathing air, or liquefied breathing oxygen.

(c) Containers normally removed from apparatus for refilling shall be equipped with a dial indicating gage which shows the pressure in the container.

(d) Compressed breathing gas contained valves or a separate charging system or adapter provided with each apparatus shall be equipped with outlet threads specified for the service by the American Standards Association, Compressed Gas Cylinder Valve Outlet and Inlet Connections, B57.1-1965. B57.1-1965 is incorporated by reference and has been approved by the Director of the Federal Register in accordance with 5 U.S.C. 552(a) and 1 CFR part 51. Copies may be obtained from American National Standards Institute, Inc., 1430 Broadway, New York, NY. Copies may be inspected at the NIOSH, Certification and Quality Assurance Branch, 1095 Willowdale Road, Morgantown, WV 26505-2888, or at the Office of the Federal Register, 800 North Capitol Street, NW., suite 700, Washington, DC.

**§ 84.82 Gas pressure gages; minimum requirements.**

(a) Gas pressure gages employed on compressed breathing gas containers shall be calibrated in pounds per square inch.

(b) Liquid-level gages shall be calibrated in fractions of total container capacity, or in units of liquid volume.

(c) Gas pressure gages other than those specified in paragraphs (a) and (b) of this section shall be calibrated in:

- (1) Pounds per square inch; or
- (2) In fractions of total container capacity; or
- (3) Both in pounds per square inch and fractions of total container capacity.

(d)(1) Dial-indicating gages shall be reliable to within  $\pm 5$  percent of full scale when tested both up and down the scale at each of 5 equal intervals.

(2) The full-scale graduation of dial-indicating gages shall not exceed 150 percent of the maximum rated cylinder pressures specified for the container in applicable Department of Transportation specifications or permits.

(e)(1) Stem-type gages shall be readable by sight and by touch and shall have a stem travel distance of not less than one-fourth inch between each graduation.

(2) A minimum of five graduations shall be engraved on the stem of each gage and these graduations shall include readings for empty, one-quarter, one-half, three-quarters, and full.

(3) Stem gage readings shall not vary from true readings by more than one-sixteenth inch per inch of stem travel.

(f) The loss of gas through a broken gage or severed gage connection shall not exceed 70 liters per minute when the cylinder pressure is 6,900 kN/m<sup>2</sup> (1,000 pounds per square inch gage) or when the liquid level is at one-half.

(g) Where gages are connected to the apparatus through a gage line, the gage and line shall be capable of being isolated from the apparatus except where the failure of the gage or line would not impair the performance or service life of the apparatus.

(h) Oxygen pressure gages shall have the words "Oxygen" and "Use No Oil" marked prominently on the gage.

(i)(1) Apparatus using compressed breathing gas, except apparatus classified for escape only, shall be equipped with gages visible to the wearer which indicate the remaining gas content in the container.

(2) Apparatus using liquefied breathing gas, except apparatus classified for escape only, shall be equipped with gages visible to the wearer which indicate the remaining liquid content in the container;



however, where the liquid content cannot be rapidly vented, and the service time of the device begins immediately after filling, a timer shall be provided in place of a visible gage.

**§ 84.83 Timers; elapsed time indicators; remaining service life indicators; minimum requirements.**

(a) Elapsed time indicators shall be provided for apparatus with a chemical oxygen source, except:

(1) Apparatus used for escape only; or  
(2) Liquefied breathing gas apparatus equipped with gages visible to the wearer which indicate the remaining liquid content in the container.

(b) The timer or other indicator shall be accurately calibrated in minutes of remaining service life.

(c) Timers shall be readable by sight and by touch during use by the wearer.

(d) Timers shall be equipped with automatically preset alarms which will warn the wearer for a period of 7 seconds or more after the preset time has elapsed.

(e) Remaining service-life indicators or warning devices shall be provided in addition to a pressure gage on compressed gas self-contained breathing apparatus, except apparatus used for escape only, and shall operate automatically without preadjustment by the wearer.

(f) Each remaining service-life indicator or warning device shall give an alarm when the remaining service life of the apparatus is reduced within a range of 20 to 25 percent of its rated service time.

**§ 84.84 Hand-operated valves; minimum requirements.**

(a) Hand-operated valves shall be designed and constructed to prevent removal of the stem from the valve body during normal usage to insure against a sudden release of the full pressure of the container when the valve is opened.

(b) Valves shall be designed or positioned to prevent accidental opening and closing, and damage from external forces.

(c) Valves operated during use of the apparatus shall be installed in locations where they can be readily adjusted by the wearer.

(d) Main-line valves, designed and constructed to conserve gas in the event of a regulator or demand valve failure, shall be provided in addition to gas container valves, except when such failure will not affect performance.

(e) Hand-operated bypass systems designed and constructed to permit the wearer to breathe and to conserve his gas supply in the event of a regulator or demand valve failure, shall be provided where necessary.

(f) Valves installed on apparatus shall be clearly distinguishable from one another by sight and touch.

(g) The bypass system valve control shall be colored red.

(h) A main-line or bypass valve or system will not be required on apparatus for escape only.

(i) Safety relief valves or systems, designed and constructed to release excess pressure in the breathing circuit, shall be provided on closed-circuit apparatus, and shall meet the following requirements:

(1) The relief valve or system shall operate automatically when the pressure in the breathing circuit on the inhalation side of the breathing bag reaches 13 mm. (one-half inch) water-column height of pressure above the minimum pressure required to fill the breathing bag, within the breathing resistance requirements for the apparatus.

(2) The relief valve or system shall be designed to prevent external atmospheres from entering the breathing circuit.

(3) The relief valve or system shall be designed to permit manual overriding for test purposes and in the event of a failure in the valve or system.

**§ 84.85 Breathing bags; minimum requirements.**

(a) Breathing bags shall have sufficient volume to prevent gas waste during exhalation and to provide an adequate reserve for inhalation.

(b) Breathing bags shall be constructed of materials which are flexible and resistant to gasoline vapors.

(c) Breathing bags shall be installed in a location which will protect them from damage or collapse by external forces, except on apparatus classified for escape only.

**§ 84.86 Component parts exposed to oxygen pressures; minimum requirements.**

Each applicant shall certify that the materials employed in the construction of component parts exposed to oxygen pressures above atmospheric pressure are safe and compatible for their intended use.

**§ 84.87 Compressed gas filters; minimum requirements.**

All self-contained breathing apparatus using compressed gas shall have a filter downstream of the gas source to effectively remove particles from the gas stream.

**§ 84.88 Breathing bag test.**

(a) Breathing bags will be tested in an air atmosphere saturated with gasoline vapor at room temperature (24–30 °C./ 75–85 °F.) for a continuous period of

twice the rated time of the apparatus (except for apparatus for escape only where the test period shall be the rated time of the apparatus).

(b) The bag will be operated during this test by a breathing machine with 24 respirations per minute and a minute-volume of 40 liters.

(c) A breathing machine cam with a work rate of 622 kp.-m./min. will be used. The dimensions of a suitable breathing machine cam are available from the Institute upon request.

(d) The air within the bag(s) shall not contain more than 100 parts per million of gasoline vapor at the end of the test.

**§ 84.89 Weight requirement.**

(a) The completely assembled and fully charged apparatus shall not weigh more than 16 kg. (35 pounds); however, where the weight decreases by more than 25 percent of its initial charge weight during its rated service life, the maximum allowable weight of a completely assembled and fully charged apparatus shall be 18 kg. (40 pounds).

(b) Where an apparatus employs equipment which contributes materially to the wearer's comfort, e.g., a cooling system, the completely assembled and fully charged apparatus shall not weigh more than 18 kg. (40 pounds) regardless of the decrease in weight during use.

**§ 84.90 Breathing resistance test; inhalation.**

(a) Resistance to inhalation airflow will be measured in the facepiece or mouthpiece while the apparatus is operated by a breathing machine as described in § 84.88.

(b) The inhalation resistance of open-circuit apparatus shall not exceed 32 mm. (1.25 inch) water-column height (at a flow rate of 120 liters per minute).

(c) The inhalation resistance of closed-circuit apparatus shall not exceed the difference between exhalation resistance (§ 84.91(e)) and 10 cm. (4 inches) water-column height.

**§ 84.91 Breathing resistance test; exhalation.**

(a) Resistance to exhalation airflow will be measured in the facepiece or mouthpiece of open-circuit apparatus with air flowing at a continuous rate of 85 liters per minute.

(b) The exhalation resistance of demand apparatus shall not exceed 25 mm. (1 inch) water-column height.

(c) The exhalation resistance of pressure-demand apparatus shall not exceed the static pressure in the facepiece by more than 51 mm. (2 inches) water-column height.

(d) The static pressure (at zero flow) in the facepiece shall not exceed 38 mm. (1.5 inches) water-column height.



(e) Resistance to exhalation airflow will be measured in the facepiece or mouthpiece of closed-circuit apparatus with a breathing machine as described in § 84.88, and the exhalation resistance shall not exceed 51 mm. (2 inches) water-column height.

**§ 84.92 Exhalation valve leakage test.**

(a) Dry exhalation valves and valve seats will be subjected to a suction of 25 mm. (1 inch) water-column height while in a normal operating position.

(b) Leakage between the valve and the valve seat shall not exceed 30 milliliters per minute.

**§ 84.93 Gas flow test; open-circuit apparatus.**

(a) A static-flow test will be performed on all open-circuit apparatus.

(b) The flow from the apparatus shall be greater than 200 liters per minute when the pressure in the facepiece of demand-apparatus is lowered by 51 mm. (2 inches) water-column height when full container pressure is applied.

(c) Where pressure demand apparatus are tested, the flow will be measured at zero gage pressure in the facepiece.

(d) Where apparatus with compressed-breathing-gas containers are tested, the flow test shall also be made with 3,450 kN/m.<sup>2</sup> (500 p.s.i.g.) container pressure applied.

**§ 84.94 Gas flow test; closed-circuit apparatus.**

(a) Where oxygen is supplied by a constant-flow device only, the rate of flow shall be at least 3 liters per minute for the entire rated service time of the apparatus.

(b) Where constant flow is used in conjunction with demand flow, the constant flow shall be greater than 1.5 liters per minute for the entire rated service time.

(c) All demand-flow devices shall provide at least 30 liters of oxygen per minute when in the fully open position.

**§ 84.95 Service time test; open-circuit apparatus.**

(a) Service time will be measured with a breathing machine as described in § 84.88.

(b) The open-circuit apparatus will be classified according to the length of time it supplies air or oxygen to the breathing machine.

(c) The service time obtained on this test will be used to classify the open-circuit apparatus in accordance with § 84.53.

**§ 84.96 Service time test; closed-circuit apparatus.**

(a) The closed-circuit apparatus will be classified according to the length of

time it supplies adequate breathing gas to the wearer during man test No. 4 described in Table 4 of this subpart.

(b) The service time obtained on man test No. 4 will be used to classify the closed-circuit apparatus in accordance with § 84.53.

**§ 84.97 Test for carbon dioxide in inspired gas; open- and closed-circuit apparatus; maximum allowable limits.**

(a) Open-circuit apparatus:

(1) The concentration of carbon dioxide in inspired gas in open-circuit apparatus will be measured at the mouth while the apparatus mounted on a dummy head is operated by a breathing machine. An acceptable method for measuring the concentration of carbon dioxide is described in Bureau of Mines Report of Investigations 6865, A Machine-Test Method for Measuring Carbon Dioxide in the Inspired Air of Self-Contained Breathing Apparatus, 1966. Copies of Report of Investigations 6865 may be inspected or obtained from the NIOSH, Certification and Quality Assurance Branch, 1095 Willowdale Road, Morgantown, WV. 26505-2888.

(2) The breathing rate will be 14.5 respirations per minute with a minute-volume of 10.5 liters.

(3) A sedentary breathing machine cam will be used.

(4) The apparatus will be tested at a temperature of 27 ± 2° C. (80 ± 5° F.).

(5) A concentration of 5 percent carbon dioxide in air will be exhaled into the facepiece.

(b) Closed-circuit apparatus. The concentration of carbon dioxide in inspired gas in closed-circuit apparatus will be measured at the mouth while the parts of the apparatus contributing to dead-air space are mounted on a dummy head and operated by the breathing machine as in paragraphs (a) (1) through (5) of this section.

(c) During the testing required by paragraphs (a) and (b) of this section, the concentration of carbon dioxide in inspired gas at the mouth will be continuously recorded, and the maximum average concentration during the inhalation portion of the breathing cycle shall not exceed the following limits:

Where the service time is	Maximum allowable average concentration of carbon dioxide in inspired air percent by volume
Not more than 30 minutes .....	2.5
1 hour .....	2.0
2 hours .....	1.5
3 hours .....	1.0
4 hours .....	1.0

(d) In addition to the test requirements for closed-circuit apparatus set forth in paragraph (b) of this section, gas samples will be taken during the course of the man tests described in Tables 1, 2, 3, and 4 of this subpart. These gas samples will be taken from the closed-circuit apparatus at a point downstream of the carbon dioxide sorbent, and they shall not contain more than 0.5 percent carbon dioxide at any time, except on apparatus for escape only, using a mouthpiece only, the sample shall not contain more than 1.5 percent carbon dioxide at any time.

**§ 84.98 Tests during low temperature operation.**

(a) The applicant shall specify the minimum temperature for safe operation and two persons will perform the tests described in paragraphs (c) and (d) of this section, wearing the apparatus according to applicant's directions. At the specified temperature, the apparatus shall meet all the requirements described in paragraph (e) of this section.

(b) The apparatus will be precooled at the specified minimum temperature for 4 hours.

(c) The apparatus will be worn in the low temperature chamber for 30 minutes, or for the service time of the apparatus, whichever is less.

(d) During the test period, alternate 1-minute periods of exercise and rest will be required with the exercise periods consisting of stepping onto and off a box 21.5 cm. (8½ inches) high at a rate of 30 cycles per minute.

(e)(1) The apparatus shall function satisfactorily at the specified minimum temperature on duplicate tests.

(2) The wearer shall have sufficient unobscured vision to perform the work.

(3) The wearer shall not experience undue discomfort because of airflow restriction or other physical or chemical changes in the operation of the apparatus.

(f) Auxiliary low-temperature parts which are commercially available to the user may be used on the apparatus to meet the requirements described in paragraph (e) of this section.

**§ 84.99 Man tests; testing conditions; general requirements.**

(a) The man tests described in Tables 1, 2, 3, and 4 of this subpart represent the workload performed in the mining, mineral, or allied industries by a person wearing the apparatus tested.

(b) The apparatus tested will be worn by Institute personnel trained in the use of self-contained breathing apparatus, and the wearer will, before participating in these tests, pass a physical



examination conducted by a qualified physician.  
 (c) All man tests will be conducted by the Institute.  
 (d) The apparatus will be examined before each man test to ensure that it is in proper working order.  
 (e) Breathing resistance will be measured within the facepiece or mouthpiece and the wearer's pulse and respiration rate will be recorded during each 2 minute sample period prescribed in tests 1, 2, 3, and 4.  
 (f) Man tests 1, 2, 3, 4, 5, and 6 will be conducted in duplicate.  
 (g) If man tests are not completed through no fault of the apparatus, the test will be repeated.

**§ 84.100 Man tests 1, 2, 3, and 4; requirements.**

Man tests 1, 2, 3, and 4, set forth in Tables 1, 2, 3, and 4 of this subpart, respectively, prescribe the duration and sequence of specific activities. These tests will be conducted to—  
 (a) Familiarize the wearer with the apparatus during use;  
 (b) Provide for a gradual increase in activity;  
 (c) Evaluate the apparatus under different types of work and physical orientation; and

(d) Provide information on the operating and breathing characteristics of the apparatus during actual use.

**§ 84.101 Man test 5; requirements.**

(a) Test 5 will be conducted to determine the maximum length of time the apparatus will supply the respiratory needs of the wearer while he is sitting at rest.  
 (b) The wearer will manipulate the devices controlling the supply of breathing gas to the advantage of the apparatus.  
 (c) Samples of inspiration from within the apparatus facepiece or mouthpiece shall be taken once every 15 minutes, and shall meet the minimum requirement for oxygen specified in § 84.79(a), and the maximum allowable average concentration of carbon dioxide specified in § 84.97(c).  
 (d) One sample of inspiration will be taken in the case of 3-, 5-, and 10-minute apparatus.

**§ 84.102 Man test 6; requirements.**

(a) Man test 6 will be conducted with respect to liquefied breathing gas apparatus only.

(b) This test will be conducted to evaluate operation of the apparatus in other than vertical positions.  
 (c) The wearer will lie face downward for one-fourth the service life of the apparatus with a full charge of liquefied breathing gas, and then a one-quarter full charge of liquefied breathing gas.  
 (d) The test will be repeated with the wearer lying on each side and on his back.  
 (e) The oxygen content of the gas supplied to the wearer by the apparatus will be continuously measured.

**§ 84.103 Man tests; performance requirements.**

(a) The apparatus shall satisfy the respiratory requirements of the wearer for the classified service time.  
 (b) Fogging of the eyepiece shall not obscure the wearer's vision, and the wearer shall not experience undue discomfort because of fit or other characteristics of the apparatus.  
 (c) When the ambient temperature during testing is 24±6 °C. (75±10 °F.), the maximum temperature of inspired air recorded during man tests shall not exceed the following, after correction for deviation from 24 °C. (75 °F.):

Where service life of apparatus is—	Where percent relative humidity of inspired air is—	Maximum permissible temperature of inspired air shall not exceed—	
		°F.	°C.
¼ hour or less .....	0–100	135	57
¼ hour to ¾ hour .....	0–50	125	52
	50–100	110	43
1 to 2 hours .....	0–50	115	46
	50–100	105	41
3 hours .....	0–50	110	43
	50–100	100	38
4 hours .....	0–50	105	41
	50–100	95	35

<sup>1</sup> Where percent relative humidity is 50–100 and apparatus is designed for escape only, these maximum permissible temperatures will be increased by 5°C (10°F).

**§ 84.104 Gas tightness test; minimum requirements.**

(a) Each apparatus will be tested for tightness by persons wearing it in an

atmosphere of 1,000 p.p.m. isoamyl acetate.

(b) Six persons will each wear the apparatus in the test concentrations

specified in paragraph (a) of this section for 2 minutes and none shall detect the odor or taste of the test vapor.

**Tables to Subpart H of Part 84**

TABLE 1.—DURATION AND SEQUENCE OF SPECIFIC ACTIVITIES FOR TEST 1, IN MINUTES  
 [42 CFR part 84, subpart H]

Activity	Service time—							
	3 minutes	5 minutes	10 minutes	15 minutes	30 minutes	45 minutes	1 hour	2, 3, and 4 hours
Sampling and readings ..	.....	.....	.....	2	2	2	2	Perform 1 hour test 2, 3, or 4 times respectively.



TABLE 1.—DURATION AND SEQUENCE OF SPECIFIC ACTIVITIES FOR TEST 1, IN MINUTES—Continued  
[42 CFR part 84, subpart H]

Activity	Service time—							
	3 minutes	5 minutes	10 minutes	15 minutes	30 minutes	45 minutes	1 hour	2, 3, and 4 hours
Walks at 4.8 km. (3 miles) per hour.	3	5	3	4	8	12	18	
Sampling and readings ..			2	2	2	2	2	
Walks at 4.8 km. (3 miles) per hour.			3	5	8	12	18	
Sampling and readings ..			2	2	2	2	2	
Walks at 4.8 km. (3 miles) per hour.					6	13	16	
Sampling and readings ..					2	2	2	

TABLE 2.—DURATION AND SEQUENCE OF SPECIFIC ACTIVITIES FOR TEST 2, IN MINUTES  
[42 CFR part 84, subpart H]

Activity	Service time—							
	3 minutes	5 minutes	10 minutes	15 minutes	30 minutes	45 minutes	1 hour	2, 3 and 4 hours <sup>1</sup>
Sampling and readings .....				2	2	2	2	2
Walks at 4.8 km. (3 miles) per hour.			1	1	3	4	6	10.
Carries 23 kg. (50 pound) weight over overcast.			1 time in 2 minutes.	1 time in 2 minutes.	2 times in 4 minutes.	3 times in 6 minutes.	4 times in 8 minutes.	5 times in 10 minutes.
Walks at 4.8 km. (3 miles) per hour.				1	3	3	3	5.
Climbs vertical treadmill <sup>2</sup> (or equivalent).	1		1	1	1	1	1	1.
Walks at 4.8 km. (3 miles) per hour.			1	1		2	3	5
Climbs vertical treadmill (or equivalent).			1			1	1	1.
Sampling and readings .....					2	2	2	2.
Walks at 4.8 km. (3 miles) per hour.				2	2	3	5	11.
Climbs vertical treadmill (or equivalent).				1	1	1	1	1.
Carries 23 kg. (50 pound) weight over overcast.				1 time in 2 minutes.	3 times in 6 minutes.	4 times in 8 minutes.	5 times in 10 minutes.	5 times in 10 minutes.
Sampling and readings .....			2			2	2	2.
Walks at 4.8 km. (3 miles) per hour.				1	3	3	3	
Climbs vertical treadmill (or equivalent).			1	1	1	1	1	Then repeat above activities once.
Walks at 4.8 km. (3 miles) per hour.			2			2	3	
Climbs vertical treadmill (or equivalent).						1	1	
Carries 20 kg. (45 pound) weight and walks at 4.8 km. (3 miles) per hour.	1						2	
Walks at 4.8 km. (3 miles) per hour.	1	2				1	4	
Sampling and readings .....				2	2	2	2	

<sup>1</sup> Total test time for Test 2 for 2-hour, 3-hour, and 4-hour apparatus is 2 hours.

<sup>2</sup> Treadmill shall be inclined 15° from vertical and operated at a speed of 1 foot per second.



TABLE 3.—DURATION AND SEQUENCE OF SPECIFIC ACTIVITIES FOR TEST 3, IN MINUTES  
[42 CFR part 84, subpart H]

Activity	Service time—							
	3 minutes	5 minutes	10 minutes	15 minutes	30 minutes	45 minutes	1 hour	2, 3 and 4 hours <sup>1</sup>
Sampling and readings .....				2 .....	2 .....	2 .....	2 .....	( <sup>2</sup> )
Walks at 4.8 km. (3 miles) per hour. ....			1 .....	1 .....	2 .....	2 .....	3 .....	
Runs at 9.7 km. (6 miles) per hour. ....	1	1 .....	1 .....	1 .....	1 .....	1 .....	1 .....	
Pulls 20 kg. (45 pound) weight to 5 feet. ....		15 times in 1 minute.		30 times in 2 minutes.	30 times in 2 minutes.	30 times in 2 minutes.	60 times in 6 minutes.	
Lies on side .....	1/2	1 .....	1 .....	2 .....	3 .....	4 .....	5 .....	
Lies on back .....	1/2	1 .....	1 .....	2 .....	2 .....	3 .....	3 .....	
Crawls on hands and knees .....	1	1 .....	1 .....	2 .....	2 .....	2 .....	2 .....	
Sampling and readings .....			2 .....		2 .....	2 .....	2 .....	
Runs at 9.7 km. (6 miles) per hour. ....				1 .....	1 .....	1 .....	1 .....	
Walks at 4.8 km. (3 miles) per hour. ....					2 .....	8 .....	10 .....	
Pulls 20 kg. (45 pound) weight to 5 feet. ....			30 times in 2 minutes.		60 times in 6 minutes.	60 times in 6 minutes.	60 times in 6 minutes.	
Sampling and readings .....				2 .....		2 .....	2 .....	
Walks at 4.8 km. (3 miles) per hour. ....			1 .....		3 .....	4 .....	10 .....	
Lies on side .....						2 .....	4 .....	
Lies on back .....						2 .....	1 .....	
Sampling and readings .....					2 .....	2 .....	2 .....	

<sup>1</sup> Total test time for Test 3 for 2-hour, 3-hour, and 4-hour apparatus is 2 hours.

<sup>2</sup> Perform test No. 3 for 1 hr. apparatus; then perform test No. 1 for 1 hour apparatus.



TABLE 4.—DURATION AND SEQUENCE OF SPECIFIC ACTIVITIES FOR TEST 4, IN MINUTES  
[42 CFR part 84, subpart H]

Activity	Service time—									
	3 minutes	5 minutes	10 minutes	15 minutes	30 minutes	45 minutes	1 hour	2 hours	3 hours	4 hours
Sampling and readings .....	.....	.....	.....	.....	.....	.....	.....	.....	.....	.....
Walks at 4.8 km. (3 miles) per hour .....	.....	.....	.....	.....	.....	.....	.....	.....	.....	.....
Climbs vertical treadmill <sup>1</sup> (or equivalent) .....	1	1	1	1	1	1	1	1	1	1
Walks at 4.8 km. (3 miles) per hour .....	.....	.....	.....	.....	.....	.....	.....	.....	.....	.....
Pulls 20 kg. (45 pound) weight to 5 feet .....	.....	30 times in 2 min- utes.	30 times in 2 min- utes.	30 times in 2 min- utes.	60 times in 5 min- utes.	60 times in 5 min- utes.	60 times in 5 min- utes.	60 times in 5 min- utes.	60 times in 5 min- utes.	60 times in 5 min- utes.
Walks at 4.8 km. (3 miles) per hour .....	.....	.....	.....	.....	.....	.....	.....	.....	.....	.....
Carries 23 kg. (50 pound) weight over overcast .....	.....	.....	.....	1 time in 1 minute.	1 time in 1 minute.	1 time in 1 minute.	2 times in 3 min- utes.	2 times in 3 min- utes.	2 times in 3 min- utes.	2 times in 3 min- utes.
Sampling and readings .....	.....	.....	.....	.....	.....	.....	.....	.....	.....	.....
Walks at 4.8 km. (3 miles) per hour .....	.....	.....	.....	.....	.....	.....	.....	.....	.....	.....
Runs at 9.7 km. (6 miles) per hour .....	.....	.....	.....	.....	.....	.....	.....	.....	.....	.....
Carries 23 kg. (50 pound) weight over overcast .....	.....	.....	.....	.....	.....	.....	.....	.....	.....	.....
Pulls 20 kg (45 pound) weight to 5 feet .....	15 times in 1 minute.	.....	.....	.....	.....	.....	.....	.....	.....	.....
Sampling and readings .....	.....	.....	.....	.....	.....	.....	.....	.....	.....	.....
Walks at 4.8 km. (3 miles) per hour .....	1	.....	.....	.....	.....	.....	.....	.....	.....	.....
Pulls 20 kg. (45 pound) weight to 5 feet .....	.....	.....	.....	.....	.....	.....	.....	.....	.....	.....
Carries 20 kg. (45 pound) weight and walks at 4.8 km. (3 miles) per hour .....	.....	.....	.....	.....	.....	.....	.....	.....	.....	.....
Sampling and readings .....	.....	.....	.....	.....	.....	.....	.....	.....	.....	.....

<sup>1</sup> Treadmill shall be inclined 15° from vertical and operated at a speed of 30 cm. (1 foot) per second.  
<sup>2</sup> Perform test No. 1 for 30-minute apparatus; then perform test No. 4 for 1-hour apparatus; then perform test No. 1 for 30-minute apparatus.  
<sup>3</sup> Perform test No. 1 for 1-hour apparatus; then perform test No. 4 for 1-hour apparatus; then perform test No. 1 for 1-hour apparatus.  
<sup>4</sup> Perform test No. 1 for 1-hour apparatus; then perform test No. 4 for 1-hour apparatus; then perform test No. 1 for 1-hour apparatus twice (i.e., two one-hour tests).



**Subpart I—Gas Masks****§ 84.110 Gas masks; description.**

(a) Gas masks including all completely assembled air purifying masks designed for use as respiratory protection during entry into atmospheres not immediately dangerous to life or health or escape only from hazardous atmospheres containing adequate oxygen to support life are described as follows:

(1) *Front-mounted or back-mounted gas mask.* A gas mask which consists of a full facepiece, a breathing tube, a canister at the front or back, a canister harness, and associated connections.

(2) *Chin-style gas mask.* A gas mask which consists of a full facepiece, a canister which is usually attached to the facepiece, and associated connections.

(3) *Escape gas mask.* A gas mask designed for use during escape only from hazardous atmospheres which consists of a facepiece or mouthpiece, a canister, and associated connections.

(b) Gas masks shall be further described according to the types of gases or vapors against which they are designed to provide respiratory protection, as follows:

Type of front-mounted or back-mounted gas mask:

- Acid gas<sup>1 2 3</sup>
- Ammonia
- Carbon monoxide
- Organic Vapor<sup>1 2 3</sup>
- Other gas(es) and vapor(s)<sup>1 2 3</sup>
- Combination of two or more of the above gases and vapors.<sup>1 2 3</sup>
- Combination of acid gas, ammonia, carbon monoxide, and organic vapors.<sup>1 2 3</sup>

Type of chin-style gas mask:

- Acid gas<sup>1 2 3</sup>
- Ammonia
- Carbon monoxide
- Organic vapor<sup>1 2 3</sup>
- Other gas(es) and vapor<sup>1 2 3</sup>
- Combination of two or more of the above gases and vapors.<sup>1 2 3</sup>

Type of escape gas mask:

- Acid gas<sup>1 2 3 4</sup>
- Ammonia<sup>4</sup>
- Carbon monoxide
- Organic vapor<sup>1 2 3 4</sup>
- Other gas(s) and vapor(s)<sup>1 2 3 4</sup>
- Combination of two or more of the above gases and vapors.<sup>1 2 3 4</sup>

<sup>1</sup> Approval may be for acid gases or organic vapors as a class or for specific acid gases or organic vapors.

<sup>2</sup> Not for use against gases or vapors with poor warning properties (except where MSHA or Occupational Safety and Health Administration standards permit such use for a specific gas or vapor), or those which generate high heats or reaction with sorbent materials in the canister.

<sup>3</sup> Use of the gas mask may be limited by factors such as lower explosive limit, toxicological effects, and facepiece fit. Limitations on gas mask service life and sorbent capacity limitations shall be specified by the applicant in instructions for selection, use and maintenance of the gas mask.

<sup>4</sup> Eye protection may be required in certain concentrations of gases and vapors.

(c) Gas masks for respiratory protection against gases and vapors other than those specified in paragraph (b) of this section, may be approved upon submittal of an application in writing for approval to the Certification and Quality Assurance Branch listing the gas or vapor and suggested maximum use concentration for the specific type of gas mask. The Institute will consider the application and accept or reject it on the basis of effect on the wearer's health and safety and any field experience in use of gas masks for such exposures. If the application is accepted, the Institute will test such masks in accordance with the requirements of this subpart.

**§ 84.111 Gas masks; required components.**

(a) Each gas mask described in § 84.110 shall, where its design requires, contain the following component parts:

- (1) Facepiece or mouthpiece and noseclip;
  - (2) Canister or cartridge;
  - (3) Canister harness;
  - (4) External check valve; and
  - (5) Breathing tube.
- (b) The components of each gas mask shall meet the minimum construction requirements set forth in subpart G of this part.

**§ 84.112 Canisters and cartridges in parallel; resistance requirements.**

Where two or more canisters or cartridges are used in parallel, their resistance to airflow shall be essentially equal.

**§ 84.113 Canisters and cartridges; color and markings; requirements.**

The color and markings of all canisters and cartridges or labels shall conform with the requirements of the American National Standards Institute, American National Standard for Identification of Air-Purifying Respirator Canisters and Cartridges, ANSI K13.1-1973. ANSI K13.1 is incorporated by reference and has been approved by the Director of the Federal Register in accordance with 5 U.S.C. 552(a) and 1 CFR part 51. Copies may be obtained from American National Standards Institute, Inc., 1430 Broadway, New York, NY 10018. Copies may be inspected at the NIOSH, Certification and Quality Assurance Branch, 1095 Willowdale Road,

Morgantown, WV 26505-2888, or at the Office of the Federal Register, 800 North Capitol Street, NW., suite 700, Washington, DC.

**§ 84.114 Filters used with canisters and cartridges; location; replacement.**

(a) Particulate matter filters used in conjunction with a canister or cartridge shall be located on the inlet side of the canister or cartridge.

(b) Filters shall be incorporated in or firmly attached to the canister or cartridge and each filter assembly shall, where applicable, be designed to permit its easy removal from and replacement in the canister or cartridge.

**§ 84.115 Breathing tubes; minimum requirements.**

Flexible breathing tubes used in conjunction with gas masks shall be designed and constructed to prevent:

- (a) Restriction of free head movement;
- (b) Disturbance of the fit of facepieces or mouthpieces;
- (c) Interference with the wearer's activities; and
- (d) Shutoff of airflow due to kinking, or from chin or arm pressure.

**§ 84.116 Harnesses; installation and construction; minimum requirements.**

(a) Each gas mask shall, where necessary, be equipped with a suitable harness designed and constructed to hold the components of the gas mask in position against the wearer's body.

(b) Harnesses shall be designed and constructed to permit easy removal and replacement of gas mask parts, and where applicable, provide for holding a full facepiece in the ready position when not in use.

**§ 84.117 Gas mask containers; minimum requirements.**

(a) Gas masks shall be equipped with a substantial, durable container bearing markings which show the applicant's name, the type and commercial designation of mask it contains and all appropriate approval labels.

(b) Containers for gas masks shall be designed and constructed to permit easy removal of the mask.

**§ 84.118 Half-mask facepieces, full facepieces, and mouthpieces; fit; minimum requirements.**

(a) Half-mask facepieces and full facepieces shall be designed and constructed to fit persons with various facial shapes and sizes either:

- (1) By providing more than one facepiece size; or
- (2) By providing one facepiece size which will fit varying facial shapes and sizes.

(b) Full facepieces shall provide for optional use of corrective spectacles or



lenses, which shall not reduce the respiratory protective qualities of the gas mask.

(c) Half-mask facepieces shall not interfere with the fit of common industrial safety spectacles, as determined by the Institute's facepiece tests in § 84.124.

(d) Gas masks with mouthpieces shall be equipped with noseclips which are securely attached to the mouthpiece or gas mask and provide an airtight seal.

(e) Facepieces shall be designed to prevent eyepiece fogging.

**§ 84.119 Facepieces; eyepieces; minimum requirements.**

(a) Full facepieces shall be designed and constructed to provide adequate vision which is not distorted by the eye.

(b) All eyepieces shall be designed and constructed to be impact and penetration resistant. Federal Specification, Mask, Air Line: and Respirator, Air Filtering, Industrial, GGG-M-125d, October 11, 1965 with interim amendment-1, July 30, 1969, is

an example of an appropriate standard for determining impact and penetration resistance. Copies of GGG-M-125d may be obtained from the NIOSH, Certification and Quality Assurance Branch, 1095 Willowdale Road, Morgantown, WV 26505-2888.

**§ 84.120 Inhalation and exhalation valves; minimum requirements.**

(a) Inhalation and exhalation valves shall be provided where necessary and protected against damage and distortion.

(b) Inhalation valves shall be designed and constructed to prevent excessive exhaled air from adversely affecting cartridges, canisters, and filters.

(c) Exhalation valves shall be protected against external influence, and designed and constructed to prevent inward leakage of contaminated air.

**§ 84.121 Head harnesses; minimum requirements.**

(a) Facepieces shall be equipped with adjustable and replaceable head

harnesses, designed and constructed to provide adequate tension during use and an even distribution of pressure over the entire area in contact with the face.

(b) Mouthpieces shall be equipped, where applicable, with adjustable and replaceable harnesses designed and constructed to hold the mouthpiece in place.

**§ 84.122 Breathing resistance test; minimum requirements.**

(a) Resistance to airflow will be measured in the facepiece or mouthpiece of a gas mask mounted on a breathing machine both before and after each test conducted in accordance with §§ 84.124, 84.125, and 84.126, with air flowing at a continuous rate of 85 liters per minute.

(b) The maximum allowable resistance requirements for gas masks are as follows:

**MAXIMUM RESISTANCE**  
[mm. water-column height]

Type of gas mask	Inhalation		Exhalation
	Initial	Final <sup>1</sup>	
Front-mounted or back-mounted (without particulate filter) .....	60	75	20
Front-mounted or back-mounted (with approved particulate filter) .....	70	85	20
Chin-style (without particulate filter) .....	40	55	20
Chin-style (with approved particulate filter) .....	65	80	20
Escape (without particulate filter) .....	60	75	20
Escape (with approved particulate filter) .....	70	85	20

<sup>1</sup> Measured at end of the service life specified in Tables 5, 6, and 7 of this subpart.

**§ 84.123 Exhalation valve leakage test.**

(a) Dry exhalation valves and valve seats will be subjected to a suction of 25 mm. water-column height while in a normal operating position.

(b) Leakage between the valve and valve seat shall not exceed 30 milliliters per minute.

**§ 84.124 Facepiece tests; minimum requirements.**

(a) The complete gas mask will be fitted to the faces of persons having varying facial shapes and sizes.

(b) Where the applicant specifies a facepiece size or sizes for the gas mask, together with the approximate measurements of faces they are designed to fit, the Institute will insure that test subjects suit such facial measurements.

(c) Any gas mask parts which must be removed to perform the facepiece or mouthpiece fit test shall be replaceable without special tools and without disturbing the facepiece or mouthpiece fit.

(d) The facepiece or mouthpiece fit test, using positive or negative pressure recommended by the applicant and described in his instructions will be used before each test specified in paragraph (e) of this section, and in § 84.125.

(e)(1) Each wearer will enter a chamber containing 100 p.p.m. isoamyl acetate vapor for a half-mask facepiece and 1,000 p.p.m. isoamyl acetate vapor for a full facepiece or mouthpiece.

(2) The facepiece or mouthpiece may be adjusted, if necessary, in the test chamber before starting the tests.

(3) Each wearer will remain in the chamber for 8 minutes while performing the following activities:

- (i) Two minutes, nodding and turning head;
- (ii) Two minutes, calisthenic arm movements;
- (iii) Two minutes, running in place; and

(iv) Two minutes, pumping with a tire pump into a 28 liter (1 cubic foot) container.

(4) Each wearer shall not detect the odor of isoamyl acetate during the test.

**§ 84.125 Particulate tests; canisters containing particulate filters; minimum requirements.**

Gas mask canisters containing filters for protection against particulates (e.g. dusts, fumes, mists, and smokes) in combination with gases, vapors, or gases and vapors, shall also comply with the requirements as prescribed in §§ 84.170 through 84.183, except for the airflow resistance test of § 84.181.

**§ 84.126 Canister bench tests; minimum requirements.**

(a)(1) Bench tests, except for carbon monoxide tests, will be made on an apparatus that allows the test atmosphere at 50±5 percent relative humidity and room temperature (25±2.5 °C.) to enter the canister continuously at concentrations and rates of flow



specified in Tables 5, 6, and 7 of this subpart.

(2) Three canisters will be removed from containers and tested as received from the applicant.

(3) Two canisters, other than those described in paragraph (a)(2) of this section, will be equilibrated at room temperature by passing 25 percent relative humidity air through them at 64 liters per minute for 6 hours.

(4) Two canisters, other than those described in paragraphs (a) (2) and (3) of this section, will be equilibrated at room temperature by passing 85 percent relative humidity air through them at 64 liters per minute for 6 hours.

(5) The equilibrated canisters will be resealed, kept in an upright position at

room temperature, and tested within 18 hours.

(b) Front-mounted and back-mounted gas mask canisters will be tested and shall meet the minimum requirements set forth in Table 5 of this subpart.

(c)(1) Front-mounted, and back-mounted, and chin-style canisters designated as providing respiratory protection against gases, ammonia, organic vapors, carbon monoxide and particulate contaminants shall have a window or other indicator to warn the gas mask wearer when the canister will no longer satisfactorily remove carbon monoxide from the inhaled air.

(2) Other types of front- and back-mounted canisters may also be

equipped with a window or other indicator to warn of imminent leakage of other gases or vapors.

(3) The window indicator canisters will be tested as regular canisters, but shall show a satisfactory indicator change or other warning before the allowable canister penetration has occurred.

(d) Chin-style gas mask canisters shall meet the minimum requirements set forth in Table 6 of this subpart.

(e) Escape gas mask canisters shall meet the minimum requirements set forth in Table 7 of this subpart.

**Tables to Subpart I of Part 84**

**TABLE 5.—CANISTER BENCH TESTS AND REQUIREMENTS FOR FRONT-MOUNTED AND BACK-MOUNTED GAS MASK CANISTERS**

[42 CFR part 84, subpart I]

Canister type	Test condition	Test atmosphere			Number of tests	Maximum allowable penetration (parts per million)	Minimum service life (minutes) <sup>1</sup>
		Gas or vapor	Concentration (parts per million)	Flow rate (liters per minute)			
Acid gas .....	As received	SO <sub>2</sub>	20,000	64	3	5	12
		Cl <sub>2</sub>	20,000	64	3	5	12
	Equilibrated	SO <sub>2</sub>	20,000	32	4	5	12
		Cl <sub>2</sub>	20,000	32	4	5	12
Organic vapor .....	As received	CCl <sub>4</sub>	20,000	64	3	5	12
		CCl <sub>4</sub>	20,000	32	4	5	12
Ammonia .....	As received	NH <sub>3</sub>	30,000	64	3	50	12
		NH <sub>3</sub>	30,000	32	4	50	12
Carbon monoxide .....	As received	CO	20,000	<sup>4</sup> 64	2	( <sup>3</sup> )	60
		CO	5,000	<sup>2</sup> 32	3	( <sup>3</sup> )	60
		CO	3,000	<sup>2</sup> 32	3	( <sup>3</sup> )	60
Combination of 2 or 3 of above types <sup>5</sup>							
Combination of all above types <sup>6</sup>							

<sup>1</sup> Minimum life will be determined at the indicated penetration.

<sup>2</sup> Relative humidity of test atmosphere will be 95±3pct; temperature of test atmosphere will be 25±2.5° C.

<sup>3</sup> Maximum allowable CO penetration will be 385 cm<sup>3</sup> during the minimum life. The penetration shall not exceed 500 p/m during this time.

<sup>4</sup> Relative humidity of test atmosphere will be 95±3pct; temperature of test atmosphere entering the test fixture will be 0±2.5°C - 0°C.

<sup>5</sup> Test conditions and requirements will be applicable as shown in this table.

<sup>6</sup> Test conditions and requirements will be applicable as shown in this table, except the minimum service lives for acid gas, organic vapor, and ammonia will be 6 min instead of 12 min.

**TABLE 6.—Canister Bench Tests and Requirements for Chin-Style Gas Mask Canisters**

[42 CFR part 84, subpart I]

Canister type	Test condition	Test atmosphere			Number of tests	Maximum allowable penetration (parts per million)	Minimum service life (minutes) <sup>1</sup>
		Gas or vapor	Concentration (parts per million)	Flow rate (liters per minute)			
Acid gas .....	As received	SO <sub>2</sub>	50,000	64	3	5	12
		Cl <sub>2</sub>	5,000	64	3	5	12
	Equilibrated	SO <sub>2</sub>	5,000	32	4	5	12
		Cl <sub>2</sub>	5,000	32	4	5	12
Organic vapor .....	As received	CCl <sub>4</sub>	5,000	64	3	5	12
		CCl <sub>4</sub>	5,000	32	4	5	12
Ammonia .....	As received	NH <sub>3</sub>	5,000	64	3	50	12
		NH <sub>3</sub>	5,000	32	4	50	12
Carbon monoxide .....	As received	CO	20,000	<sup>2</sup> 64	2	( <sup>3</sup> )	60
		CO	5,000	<sup>4</sup> 32	3	( <sup>3</sup> )	60



TABLE 6—Canister Bench Tests and Requirements for Chin-Style Gas Mask Canisters  
[42 CFR part 84, subpart I]

Canister type	Test condition	Test atmosphere			Number of tests	Maximum allowable penetration (parts per million)	Minimum service life (minutes) <sup>1</sup>
		Gas or vapor	Concentration (parts per million)	Flow rate (liters per minute)			
Combination of 2 or 3 of above types <sup>5</sup> Combination of all above types <sup>6</sup>		CO	3,000	<sup>2</sup> 32	3	( <sup>3</sup> )	60

<sup>1</sup> Minimum life will be determined at the indicated penetration.

<sup>2</sup> Relative humidity of test atmosphere will be 95 ± 3pct; temperature of test atmosphere will be 25 ± 2.5° C.

<sup>3</sup> Maximum allowable CO penetration will be 385 cm<sup>3</sup> during the minimum life. The penetration shall not exceed 500 p/m during this time.

<sup>4</sup> Relative humidity of test atmosphere will be 95 ± 3pct; temperature of test atmosphere entering the test fixture will be 0 ± 2.5° C - 0° C.

<sup>5</sup> Test conditions and requirements will be applicable as shown in this table.

<sup>6</sup> Test conditions and requirements will be applicable as shown in this table, except the minimum service lives for acid gas, organic vapor, and ammonia will be 6 min instead of 12 min.

TABLE 7.—CANISTER BENCH TESTS AND REQUIREMENTS FOR ESCAPE GAS MASK CANISTERS  
[42 CFR part 84, subpart I]

Canister type	Test condition	Test atmosphere			Number of tests	Maximum allowable penetration (parts per million)	Minimum service life (minutes) <sup>1</sup>
		Gas or vapor	Concentration (parts per million)	Flow rate (liters per minute)			
Acid gas .....	As received .....	SO <sub>2</sub>	5,000	64	3	5	12
	Equilibrated .....	Cl <sub>2</sub>	5,000	64	3	5	12
Organic vapor .....	As received .....	SO <sub>2</sub>	5,000	32	4	5	12
		Cl <sub>2</sub>	5,000	32	4	5	12
	Equilibrated .....	CCl <sub>4</sub>	5,000	64	3	5	12
		CCl <sub>4</sub>	5,000	32	4	5	12
Ammonia .....	As received .....	NH <sub>3</sub>	5,000	64	3	50	12
	Equilibrated .....	NH <sub>3</sub>	5,000	32	4	50	12
Carbon monoxide .....	As received .....	CO	10,000	<sup>2</sup> 32	2	( <sup>3</sup> )	<sup>4</sup> 60
		CO	5,000	<sup>5</sup> 32	3	( <sup>3</sup> )	60
		CO	3,000	<sup>2</sup> 32	3	( <sup>3</sup> )	60

<sup>1</sup> Minimum life will be determined at the indicated penetration.

<sup>2</sup> Relative humidity of test atmosphere will be 95 ± 3pct; temperature of test atmosphere will be 25 ± 2.5° C.

<sup>3</sup> Maximum allowable CO penetration will be 385 cm<sup>3</sup> during the minimum life. The penetration shall not exceed 500 p/m during this time.

<sup>4</sup> If effluent temperature exceeds 100° C during this test, the escape gas mask shall be equipped with an effective heat exchanger.

<sup>5</sup> Relative humidity of test atmosphere will be 95 ± 3 pct; temperature of test atmosphere entering the test fixture will be 0 ± 2.5° C - 0° C.

**Subpart J—Supplied-Air Respirators**

**§ 84.130 Supplied-air respirators; description.**

Supplied-air respirators, including all completely assembled respirators designed for use as respiratory protection during entry into and escape from atmospheres not immediately dangerous to life or health are described as follows:

(a) *Type "A" supplied-air respirators.* A hose mask respirator, for entry into and escape from atmospheres not immediately dangerous to life or health, which consists of a motor-driven or hand-operated blower that permits the free entrance of air when the blower is not operating, a strong large-diameter hose having a low resistance to airflow, a harness to which the hose and the life-line are attached and a tight-fitting facepiece.

(b) *Type "AE" supplied-air respirators.* A Type "A" supplied-air respirator equipped with additional devices designed to protect the wearer's head and neck against impact and abrasion from rebounding abrasive material, and with shielding material such as plastic, glass, woven wire, sheet metal, or other suitable material to protect the window(s) of facepieces, hoods, and helmets which do not unduly interfere with the wearer's vision and permit easy access to the external surface of such window(s) for cleaning.

(c) *Type "B" supplied-air respirators.* A hose mask respirator, for entry into and escape from atmospheres not immediately dangerous to life or health, which consists of a strong large-diameter hose with low resistance to airflow through which the user draws inspired air by means of his lungs alone,

a harness to which the hose is attached, and a tight-fitting facepiece.

(d) *Type "BE" supplied-air respirators.* A type "B" supplied-air respirator equipped with additional devices designed to protect the wearer's head and neck against impact and abrasion from rebounding abrasive material, and with shielding material such as plastic, glass, woven wire, sheet metal, or other suitable material to protect the window(s) of facepieces, hoods, and helmets which do not unduly interfere with the wearer's vision and permit easy access to the external surface of such window(s) for cleaning.

(e) *Type "C" supplied-air respirators.* An airline respirator, for entry into and escape from atmospheres not immediately dangerous to life or health, which consists of a source of respirable breathing air, a hose, a detachable coupling, a control valve, orifice, a



demand valve or pressure demand valve, an arrangement for attaching the hose to the wearer, and a facepiece, hood, or helmet.

(f) *Type "CE" supplied-air respirators.* A type "C" supplied-air respirator equipped with additional devices designed to protect the wearer's head and neck against impact and abrasion from rebounding abrasive material, and with shielding material such as plastic, glass, woven wire, sheet metal, or other suitable material to protect the window(s) of facepieces, hoods, and helmets which do not unduly interfere with the wearer's vision and permit easy access to the external surface of such window(s) for cleaning.

**§ 84.131 Supplied-air respirators; required components.**

(a) Each supplied-air respirator described in § 84.130 shall, where its design requires, contain the following component parts:

- (1) Facepiece, hood, or helmet;
- (2) Air supply valve, orifice, or demand or pressure-demand regulator;
- (3) Hand operated or motor driven air blower;
- (4) Air supply hose;
- (5) Detachable couplings;
- (6) Flexible breathing tube; and
- (7) Respirator harness.

(b) The component parts of each supplied-air respirator shall meet the minimum construction requirements set forth in subpart G of this part.

**§ 84.132 Breathing tubes; minimum requirements.**

Flexible breathing tubes used in conjunction with supplied-air respirators shall be designed and constructed to prevent:

- (a) Restriction of free head movement;
- (b) Disturbance of the fit of facepieces, mouthpieces, hoods, or helmets;
- (c) Interference with the wearer's activities; and
- (d) Shutoff of airflow due to kinking, or from chin or arm pressure.

**§ 84.133 Harnesses; installation and construction; minimum requirements.**

(a) Each supplied-air respirator shall, where necessary, be equipped with a suitable harness designed and constructed to hold the components of the respirator in position against the wearer's body.

(b) Harnesses shall be designed and constructed to permit easy removal and replacement of respirator parts, and where applicable, provide for holding a full facepiece in the ready position when not in use.

**§ 84.134 Respirator containers; minimum requirements.**

Supplied-air respirators shall be equipped with a substantial, durable container bearing markings which show the applicant's name, the type and commercial designation of the respirator it contains, and all appropriate approval labels.

**§ 84.135 Half-mask facepieces, full facepieces, hoods, and helmets; fit; minimum requirements.**

(a) Half-mask facepieces and full facepieces shall be designed and constructed to fit persons with various facial shapes and sizes either:

- (1) By providing more than one facepiece size; or
- (2) By providing one facepiece size which will fit varying facial shapes and sizes.

(b) Full facepieces shall provide for optional use of corrective spectacles or lenses, which shall not reduce the respiratory protective qualities of the respirator.

(c) Hoods and helmets shall be designed and constructed to fit persons with various head sizes, provide for the optional use of corrective spectacles or lenses, and insure against any restriction of movement by the wearer.

(d) Facepieces, hoods, and helmets shall be designed to prevent eyepiece fogging.

**§ 84.136 Facepieces, hoods, and helmets; eyepieces; minimum requirements.**

(a) Facepieces, hoods, and helmets shall be designed and constructed to provide adequate vision which is not distorted by the eyepiece.

(b) All eyepieces except those on Types B, BE, C, and CE supplied-air respirators shall be designed and constructed to be impact and penetration resistant. Federal Specification, Mask, Air Line: and Respirator, Air Filtering, Industrial, GGG-M-125d, October 11, 1965 with interim amendment-1, July 30, 1969, is an example of an appropriate standard for determining impact and penetration resistance. Copies of GGG-M-125d may be obtained from the NIOSH, Certification and Quality Assurance Branch, 1095 Willowdale Road, Morgantown, WV 26505-2888.

(c)(1) The eyepieces of AE, BE, and CE type supplied-air respirators shall be shielded by plastic, glass, woven wire, sheet metal, or other suitable material which does not interfere with the vision of the wearer.

(2) Shields shall be mounted and attached to the facepiece to provide easy access to the external surface of the eyepiece for cleaning.

**§ 84.137 Inhalation and exhalation valves; check valves; minimum requirements.**

(a) Inhalation and exhalation valves shall be provided where necessary and protected against distortion.

(b) Exhalation valves shall be:

- (1) Protected against damage and external influence; and
- (2) Designed and constructed to prevent inward leakage of contaminated air.

(c) Check valves designed and constructed to allow airflow toward the facepiece only shall be provided in the connections to the facepiece or in the hose fitting near the facepiece of all Type A, AE, B, and BE supplied-air respirators.

**§ 84.138 Head harnesses; minimum requirements.**

Facepieces shall be equipped with adjustable and replaceable head harnesses which are designed and constructed to provide adequate tension during use, and an even distribution of pressure over the entire area in contact with the face.

**§ 84.139 Head and neck protection; supplied-air respirators; minimum requirements.**

Type AE, BE, and CE supplied-air respirators shall be designed and constructed to provide protection against impact and abrasion from rebounding abrasive materials to the wearer's head and neck.

**§ 84.140 Air velocity and noise levels; hoods and helmets; minimum requirements.**

Noise levels generated by the respirator will be measured inside the hood or helmet at maximum airflow obtainable within pressure and hose length requirements and shall not exceed 80 dBA.

**§ 84.141 Breathing gas; minimum requirements.**

(a) Breathing gas used to supply supplied-air respirators shall be respirable breathing air and contain no less than 19.5 volume-percent of oxygen.

(b) Compressed, gaseous breathing air shall meet the applicable minimum grade requirements for Type I gaseous air set forth in the Compressed Gas Association Commodity Specification for Air, G-7.1, 1966 (Grade D or higher quality). G-7.1 is incorporated by reference and has been approved by the Director of the Federal Register in accordance with 5 U.S.C. 552(a) and 1 CFR part 51. Copies may be obtained from American National Standards Institute, Inc., 1430 Broadway, New York, NY 10018. Copies may be



inspected at the NIOSH, Certification and Quality Assurance Branch, 1095 Willowdale Road, Morgantown, WV 26505-2888, or at the Office of the Federal Register, 800 North Capitol Street, NW., suite 700, Washington, DC.

(c) Compressed, liquefied breathing air shall meet the applicable minimum grade requirements for Type II liquid air set forth in the Compressed Gas Association Commodity Specification for Air, G-7.1, 1966 (Grade B or higher quality). G-7.1 is incorporated by reference and has been approved by the Director of the Federal Register in accordance with 5 U.S.C. 552(a) and 1 CFR part 51. Copies may be obtained from American National Standards Institute, Inc., 1430 Broadway, New York, NY 10018. Copies may be inspected at the NIOSH, Certification and Quality Assurance Branch, 1095 Willowdale Road, Morgantown, WV 26505-2888, or at the Office of the Federal Register, 800 North Capitol Street, NW., suite 700, Washington, DC.

**§ 84.142 Air supply source; hand-operated or motor driven air blowers; Type A supplied-air respirators; minimum requirements.**

(a) Blowers shall be designed and constructed to deliver an adequate amount of air to the wearer with either direction of rotation, unless constructed to permit rotation in one direction only, and to permit the free entrance of air to the hose when the blower is not operated.

(b) No multiple systems, whereby more than one user is supplied by one blower, will be approved, unless each hose line is connected directly to a manifold at the blower.

**§ 84.143 Terminal fittings or chambers; Type B supplied-air respirators; minimum requirements.**

(a) Blowers or connections to air supplies providing positive pressures shall not be approved for use on Type B supplied-air respirators.

(b) Terminal fittings or chambers employed in Type B supplied-air respirators, shall be:

- (1) Installed in the inlet of the hose.
- (2) Designed and constructed to provide for the drawing of air through

corrosion resistant material arranged so as to be capable of removing material larger than 0.149 mm. in diameter (149 micrometers, 100-mesh, U.S. Standard sieve).

(3) Installed to provide a means for fastening or anchoring the fitting or chamber in a fixed position in a zone of respirable air.

**§ 84.144 Hand-operated blower test; minimum requirements.**

(a) Hand-operated blowers shall be tested by attaching them to a mechanical drive and operating them 6 to 8 hours daily for a period of 100 hours at a speed necessary to deliver 50 liters of air per minute through each completely assembled respirator. Each respirator shall be equipped with the maximum length of hose with which the device is to be approved and the hose shall be connected to each blower or manifold outlet designed for hose connections.

(b) The crank speed of the hand-operated blower shall not exceed 50 revolutions per minute in order to deliver the required 50 liters of air per minute to each facepiece.

(c) The power required to deliver 50 liters of air per minute to each wearer through the maximum length of hose shall not exceed one-fiftieth horsepower, and the torque shall not exceed a force of 2.3 kg. (5 pounds) on a 20 cm. (8-inch) crank, as defined in § 84.146.

(d) The blower shall operate throughout the period without failure or indication of excessive wear of bearings or other working parts.

**§ 84.145 Motor-operated blower test; minimum requirements.**

(a) Motor-operated blowers shall be tested by operating them at their specified running speed 6 to 8 hours daily for a period of 100 hours when assembled with the kind and maximum length of hose for which the device is to be approved and when connected to each blower or manifold outlet designed for hose connections.

(b) The connection between the motor and the blower shall be so constructed that the motor may be disengaged from

the blower when the blower is operated by hand.

(c) The blower shall operate throughout the period without failure or indication of excessive wear of bearings or other working parts.

(d) Where a blower, which is ordinarily motor driven, is operated by hand, the power required to deliver 50 liters of air per minute to each wearer through the maximum length of hose shall not exceed one-fiftieth horsepower, and the torque shall not exceed a force of 2.3 kg. (5 pounds) on a 20 cm. (8-inch) crank, as defined in § 84.146.

(e) Where the respirator is assembled with the facepiece and 15 m. (50 feet) of the hose for which it is to be approved, and when connected to one outlet with all other outlets closed and operated at a speed not exceeding 50 revolutions of the crank per minute, the amount of air delivered into the respiratory-inlet covering shall not exceed 150 liters per minute.

**§ 84.146 Method of measuring the power and torque required to operate blowers.**

As shown in Figure 1 of this section, the blower crank is replaced by a wooden drum, a (13 cm. (5 inches) in diameter is convenient). This drum is wound with about 12 m. (40 feet) of No. 2 picture cord, b. A weight, c, of sufficient mass to rotate the blower at the desired speed is suspended from this wire cord. A mark is made on the cord about 3 to 4.5 m. (10 to 15 feet) from the weight, c. Another mark is placed at a measured distance (6-9 m./20-30 feet is convenient) from the first. These are used to facilitate timing. To determine the torque or horsepower required to operate the blower, the drum is started in rotation manually at or slightly above the speed at which the power measurement is to be made. The blower is then permitted to assume constant speed, and then as the first mark on the wire leaves the drum, a stopwatch is started. The watch is stopped when the second mark leaves the drum. From these data the foot-pounds per minute and the torque may be calculated.

BILLING CODE 4160-19-P



Figure 1—Apparatus for measuring power required to operate blower. (42 CFR part 84, subpart J, § 84.146)

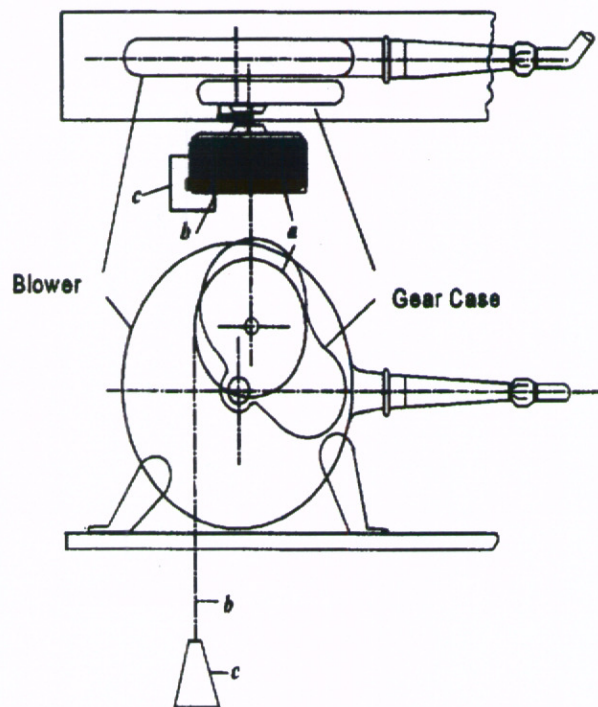

BILLING CODE 4160-19-C

**§ 84.147 Type B supplied-air respirator; minimum requirements.**

No Type B supplied-air respirator shall be approved for use with a blower or with connection to an air supply device at positive pressures.

**§ 84.148 Type C supplied-air respirator, continuous flow class; minimum requirements.**

(a) Respirators tested under this section shall be approved only when they supply respirable air at the pressures and quantities required.

(b) The pressure at the inlet of the hose connection shall not exceed 863 kN/m.<sup>2</sup> (125 pounds per square inch gage).

(c) Where the pressure at any point in the supply system exceeds 863 kN/m.<sup>2</sup> (125 pounds per square inch gage), the respirator shall be equipped with a pressure-release mechanism that will prevent the pressure at the hose connection from exceeding 863 kN/m.<sup>2</sup> (125 pounds per square inch gage) under any conditions.

**§ 84.149 Type C supplied-air respirator, demand and pressure demand class; minimum requirements.**

(a) Respirators tested under this section shall be approved only when used to supply respirable air at the pressures and quantities required.

(b) The manufacturer shall specify the range of air pressure at the point of

attachment of the air-supply hose to the air-supply system, and the range of hose length for the respirator. For example, he might specify that the respirator be used with compressed air at pressures ranging from 280–550 kN/m.<sup>2</sup> (40 to 80 pounds per square inch) with from 6 to 76 m. (15 to 250 feet) of air-supply hose.

(c) The specified air pressure at the point of attachment of the hose to the air-supply system shall not exceed 863 kN/m.<sup>2</sup> (125 pounds per square inch gage).

(d)(1) Where the pressure in the air-supply system exceeds 863 kN/m.<sup>2</sup> (125 pounds per square inch gage), the respirator shall be equipped with a pressure-release mechanism that will prevent the pressure at the point of attachment of the hose to the air-supply system from exceeding 863 kN/m.<sup>2</sup> (125 pounds per square inch gage).

(2) The pressure-release mechanism shall be set to operate at a pressure not more than 20 percent above the manufacturer's highest specified pressure. For example, if the highest specified pressure is 863 kN/m.<sup>2</sup> (125 pounds per square inch), the pressure-release mechanism would be set to operate at a maximum of 1,035 kN/m.<sup>2</sup> (150 pounds per square inch).

**§ 84.150 Air-supply line tests; minimum requirements.**

Air supply lines employed on Type A, Type B, and Type C supplied-air respirators shall meet the minimum test

requirements set forth in Table 8 of this subpart.

**§ 84.151 Harness test; minimum requirements.**

(a)(1) Shoulder straps employed on Type A supplied-air respirators shall be tested for strength of material, joints, and seams and must separately withstand a pull of 113 kg. (250 pounds) for 30 minutes without failure.

(2) Belts, rings, and attachments for life lines must withstand a pull of 136 kg. (300 pounds) for 30 minutes without failure.

(3) The hose shall be firmly attached to the harness so as to withstand a pull of 113 kg. (250 pounds) for 30 minutes without separating, and the hose attachments shall be arranged so that the pull or drag of the hose behind an advancing wearer does not disarrange the harness or exert pull upon the facepiece.

(4) The arrangement and suitability of all harness accessories and fittings will be considered.

(b)(1) The harness employed on Type B supplied-air respirators shall not be uncomfortable, disturbing, or interfere with the movements of the wearer.

(2) The harness shall be easily adjustable to various sizes.

(3) The hose shall be attached to the harness in a manner that will withstand a pull of 45 kg. (100 pounds) for 30 minutes without separating or showing signs of failure.



(4) The design of the harness and attachment of the line shall permit dragging the maximum length of hose considered for approval over a concrete floor without disarranging the harness or exerting a pull on the facepiece.

(5) The arrangement and suitability of all harness accessories and fittings will be considered.

(c) The harness employed on Type C respirators shall be similar to that required on the Type B respirator, or, it may consist of a simple arrangement for attaching the hose to a part of the wearer's clothing in a practical manner that prevents a pull equivalent to dragging the maximum length of the hose over a concrete floor from exerting pull upon the respiratory-inlet covering.

(d) Where supplied-air respirators have a rigid or partly rigid head covering, a suitable harness shall be required to assist in holding this covering in place.

**§ 84.152 Breathing tube test; minimum requirements.**

(a)(1) Type A and Type B supplied-air respirators shall employ one or two flexible breathing tubes of the nonkinking type which extend from the facepiece to a connecting hose coupling attached to the belt or harness.

(2) The breathing tubes employed shall permit free head movement, insure against closing off by kinking or by chin or arm pressure, and they shall not create a pull that will loosen the facepiece or disturb the wearer.

(b) Breathing tubes employed on Type C supplied-air respirators of the continuous flow class shall meet the minimum requirements set forth in paragraph (a) of this section, however, an extension of the connecting hose may be employed in lieu of the breathing tubes required.

(c)(1) A flexible, nonkinking type breathing tube shall:

(i) Be employed on Type C supplied-air respirators of the demand and pressure-demand class; and

(ii) Extend from the facepiece to the demand or pressure-demand valve, except where the valve is attached directly to the facepiece.

(2) The breathing tube shall permit free head movement, insure against closing off by kinking or by chin or arm pressure, and shall not create a pull that will loosen the facepiece or disturb the wearer.

**§ 84.153 Airflow resistance test, Type A and Type AE supplied-air respirators; minimum requirements.**

(a) Airflow resistance will be determined when the respirator is completely assembled with the respiratory-inlet covering, the air-supply device, and the maximum length of air-supply hose coiled for one-half its length in loops 1.5 to 2.1 m. (5 to 7 feet) in diameter.

(b) The inhalation resistance, drawn at the rate of 85 liters (3 cubic feet) per minute when the blower is not operating or under any practical condition of blower operation shall not exceed the following amounts:

Maximum length of hose for which respirator is approved		Maximum resistance, water column height	
Feet	Meters	Inches	Millimeters
75	23	1.5	38
150	46	2.5	64
250	76	3.5	89
300	91	4.0	102

(c) The exhalation resistance shall not exceed 25 mm. (1 inch) of water-column height at a flow rate of 85 liters (3 cubic feet) per minute when the blower is not operating or under any practical condition of blower operation.

**§ 84.154 Airflow resistance test; Type B and Type BE supplied-air respirators; minimum requirements.**

(a) Airflow resistance shall be determined when the respirator is completely assembled with the respiratory-inlet covering and the hose in the maximum length to be considered for approval, coiled in loops 1.5 to 2.1 m. (5 to 7 feet) in diameter.

(b) Airflow resistance shall not exceed 38 mm. (1.5 inches) of water-column height to air drawn at the flow rate of 85 liters (3 cubic feet) per minute.

(c) The exhalation resistance shall not exceed 25 mm. (1 inch) of water-column height at this flow rate.

**§ 84.155 Airflow resistance test; Type C supplied-air respirator, continuous flow class and Type CE supplied-air respirator; minimum requirements.**

The resistance to air flowing from the respirator shall not exceed 25 mm. (1

inch) of water-column height when the air flow into the respiratory-inlet covering is 115 liters (4 cubic feet) per minute.

**§ 84.156 Airflow resistance test; Type C supplied-air respirator, demand class; minimum requirements.**

(a) Inhalation resistance shall not exceed 50 millimeters (2 inches) of water at an air flow of 115 liters (4 cubic feet) per minute.

(b) The exhalation resistance to a flow of air at a rate of 85 liters (3 cubic feet) per minute shall not exceed 25 millimeters (1 inch) of water.

**§ 84.157 Airflow resistance test; Type C supplied-air respirator, pressure-demand class; minimum requirements.**

(a) The static pressure in the facepiece shall not exceed 38 mm. (1.5 inches) of water-column height.

(b) The pressure in the facepiece shall not fall below atmospheric at inhalation airflows less than 115 liters (4 cubic feet) per minute.

(c) The exhalation resistance to a flow of air at a rate of 85 liters (3 cubic feet) per minute shall not exceed the static pressure in the facepiece by more than

51 mm. (2 inches) of water-column height.

**§ 84.158 Exhalation valve leakage test.**

(a) Dry exhalation valves and valve seats will be subjected to a suction of 25 mm. water-column height while in a normal operating position.

(b) Leakage between the valve and valve seat shall not exceed 30 milliliters per minute.

**§ 84.159 Man tests for gases and vapors; supplied-air respirators; general performance requirements.**

(a) Wearers will enter a chamber containing a gas or vapor as prescribed in §§ 84.160, 84.161, 84.162, and 84.163.

(b) Each wearer will spend 10 minutes in work to provide observations on freedom of the device from leakage. The freedom and comfort allowed the wearer will also be considered.

(c) Time during the test period will be divided as follows:

(1) *Five minutes.* Walking, turning head, dipping chin; and

(2) *Five minutes.* Pumping air with a tire pump into a 28-liter (1 cubic foot) container, or equivalent work.



(d) No odor of the test gas or vapor shall be detected by the wearer in the air breathed during any such test, and the wearer shall not be subjected to any undue discomfort or encumbrance because of the fit, air delivery, or other features of the respirator during the testing period.

**§ 84.160 Man test for gases and vapors; Type A and Type AE respirators; test requirements.**

(a) The completely assembled respirator will be worn in a chamber containing 0.1±0.025 percent isoamyl acetate vapor, and the blower, the intake of the hose, and not more than 25 percent of the hose length will be located in isoamyl acetate-free air.

(b) The man in the isoamyl acetate atmosphere will draw his inspired air through the hose, connections, and all parts of the air device by means of his lungs alone (blower not operating).

(c) The 10-minute work test will be repeated with the blower in operation at any practical speed up to 50 revolutions of the crank per minute.

**§ 84.161 Man test for gases and vapors; Type B and Type BE respirators; test requirements.**

(a) The completely assembled respirator will be worn in a chamber containing 0.1±0.025 percent isoamyl acetate vapor, and the intake of the hose, and not more than 25 percent of the hose length will be located in isoamyl acetate-free air.

(b) The man in the isoamyl acetate atmosphere will draw his inspired air through the hose and connections by means of his lungs alone.

**§ 84.162 Man test for gases and vapors; Type C respirators, continuous-flow class and Type CE supplied-air respirators; test requirements.**

(a) The completely assembled respirator will be worn in a chamber containing 0.1±0.025 percent isoamyl acetate vapor, the intake of the hose will be connected to a suitable source of respirable air, and not more than 25 percent of the hose length will be located in isoamyl acetate-free air.

(b) The minimum flow of air required to maintain a positive pressure in the

respiratory-inlet covering throughout the entire breathing cycle will be supplied to the wearer, provided however, that airflow shall not be less than 115 liters per minute for tight-fitting and not less than 170 liters per minute for loose-fitting respiratory inlet-coverings.

(c) The test will be repeated with the maximum rate of flow attainable within specified operating pressures.

**§ 84.163 Man test for gases and vapors; Type C supplied-air respirators, demand and pressure-demand classes; test requirements.**

(a) The completely assembled respirator will be worn in a chamber containing 0.1±0.025 percent isoamyl acetate vapor, the intake of the hose will be connected to a suitable source of respirable air, and not more than 25 percent of the hose length will be located in isoamyl acetate-free air.

(b) The test will be conducted at the minimum pressure with the maximum hose length and will be repeated at the maximum pressure with the minimum hose length.

**Tables to Subpart J of Part 84**

**TABLE 8—AIR-SUPPLY-LINE REQUIREMENTS AND TESTS**  
[42 CFR part 84, subpart J]

Specific requirements	Requirements for the air-supply lines of the indicated type of supplied-air respirators		
	Type A	Type B	Type C
Length of hose .....	Maximum of 91 m. (300 feet), in multiples of 7.6 m. (25 feet).	Maximum of 23 m. (75 feet) in multiples of 7.6 m. (25 feet).	Maximum of 91 m. (300 feet) in multiples of 7.6 m. (25 feet). It will be permissible for the applicant to supply hose of the approved type of shorter length than 7.6 m. (25 feet) provided it meets the requirements of the part.
Air flow .....	None .....	None .....	The air-supply hose with air regulating valve or orifice shall permit a flow of not less than 115 liters (4 cubic feet) per minute to tight-fitting and 170 liters (6 cubic feet) per minute to loose-fitting respiratory-inlet coverings through the maximum length of hose for which approval is granted and at the minimum specified air-supply pressure. The maximum flow shall not exceed 425 liters (15 cubic feet) per minute at the maximum specified air-supply pressure with the minimum length of hose for which approval is granted.



TABLE 8—AIR-SUPPLY-LINE REQUIREMENTS AND TESTS—Continued  
[42 CFR part 84, subpart J]

Specific requirements	Requirements for the air-supply lines of the indicated type of supplied-air respirators		
	Type A	Type B	Type C
Air flow .....	.....do .....	.....do .....	The air-supply hose, detachable coupling, and demand valve of the demand class or pressure-demand valve of the pressure-demand class for Type C supplied-air respirators, demand and pressure-demand classes, shall be capable of delivering respirable air at a rate of not less than 115 liters (4 cubic feet) per minute to the respiratory-inlet covering at an inhalation resistance not exceeding 50 millimeters (2 inches) of water-column height measured in the respiratory-inlet covering with any combination of air-supply pressure and length of hose within the applicant's specified range of pressure and hose length. The air-flow rate and resistance to inhalation shall be measured while the demand or pressure-demand valve is actuated 20 times per minute by a source of intermittent suction. The maximum rate of flow to the respiratory-inlet covering shall not exceed 425 liters (15 cubic feet) per minute under the specified operating conditions.
Air-regulating valve .....	.....do .....	.....do .....	If an air-regulating valve is provided, it shall be so designed that it will remain at a specific adjustment, which will not be affected by the ordinary movement of the wearer. The valve must be so constructed that the air supply with the maximum length of hose and at the minimum specified air-supply pressure will not be less than 115 liters (4 cubic feet) of air per minute to tight-fitting and 170 liters (6 cubic feet) of air per minute of loose-fitting respiratory inlet coverings for any adjustment of the valve. If a demand or pressure-demand valve replaces the air-regulating valve, it shall be connected to the air-supply at the maximum air pressure for which approval is sought by means of the minimum length of air-supply hose for which approval is sought. The outlet of the demand or pressure-demand valve shall be connected to a source of intermittent suction so that the demand or pressure-demand valve is actuated approximately 20 times per minute for a total of 100,000 inhalations. To expedite this test, the rate of actuation may be increased if mutually agreeable to the applicant and NIOSH. During this test the valve shall function without failure and without excessive wear of the moving parts. The demand or pressure-demand valve shall not be damaged in any way when subjected at the outlet to a pressure or suction of 25 cm. (10 inches) of water gage for 2 minutes.
Noncollapsibility .....	The hose shall not collapse or exhibit permanent deformation when a force of 90 kg. (200 pounds) is applied for 5 minutes between 2 planes 7.6 cm. (3 inches) wide on opposite sides of the hose.	Same as Type A .....	None.



TABLE 8—AIR-SUPPLY-LINE REQUIREMENTS AND TESTS—Continued  
[42 CFR part 84, subpart J]

Specific requirements	Requirements for the air-supply lines of the indicated type of supplied-air respirators		
	Type A	Type B	Type C
Nonkinkability .....	None .....	None .....	A 7.6 m. (25 foot) section of the hose will be placed on a horizontal-plane surface and shaped into a one-loop coil with one end of the hose connected to an airflow meter and the other end of the hose supplied with air at the minimum specified supply pressure. The connection shall be in the plane of the loop. The other end of the hose will be pulled tangentially to the loop and in the plane of the loop until the hose straightens. To meet the requirements of this test the loop shall maintain a uniform near-circular shape and ultimately unfold as a spiral, without any localized deformation that decreases the flow of air to less than 90 percent of the flow when the hose is tested while remaining in a straight line.
Strength of hose and couplings.	Hose and couplings shall not separate or fail when tested with a pull of 113 kg. (250 pounds) for 5 minutes.	Same as Type A .....	Hose and couplings shall not exhibit any separation or failure when tested with a pull of 45 kg. (100 pounds) for 5 minutes and when tested by subjecting them to an internal air pressure of 2 times the maximum respirator-supply pressure that is specified by the applicant or at 173 kN/m. 2 (25 pounds per square inch) gage, whichever is higher.
Tightness .....	No air leakage shall occur when the hose and couplings are joined and the joint(s) are immersed in water and subjected to an internal air pressure of 35 kN/m. 2 (5 pounds per square inch) gage.	None .....	Leakage of air exceeding 50 cc. per minute at each coupling shall not be permitted when the hose and couplings are joined and are immersed in water, with air flowing through the respirator under a pressure of 173 kN/m. 2 (25 pounds per square inch) gage applied to the inlet end of the air-supply hose, or at twice the maximum respirator-supply pressure that is specified by the applicant, whichever is higher.
Permeation of hose by gasoline.	The permeation of the hose by gasoline will be tested by immersing 7.6 m. (25 feet) of hose and one coupling in gasoline, with air flowing through the hose at the rate of 8 liters per minute for 6 hours. The air from the hose shall not contain more than 0.01 percent by volume of gasoline vapor at the end of the test.	Same as for Type A .....	Same as for Type A, except the test period shall be 1 hour.
Detachable coupling .....	None .....	None .....	A hand-operated detachable coupling by which the wearer can readily attach or detach the connecting hose shall be provided at a convenient location. This coupling shall be durable, remain connected under all conditions of normal respirator use, and meet the prescribed tests for strength and tightness of hose and couplings.

**Subpart K—Non-Powered Air-Purifying Particulate Respirators**

**§ 84.170 Non-powered air-purifying particulate respirators; description.**

(a) Non-powered air-purifying particulate respirators utilize the wearer's negative inhalation pressure to draw the ambient air through the air-purifying filter elements (filters) to remove particulates from the ambient air. They are designed for use as respiratory protection against

atmospheres with particulate contaminants (e.g., dusts, fumes, mists) that are not immediately dangerous to life or health and that contain adequate oxygen to support life.

(b) Non-powered air-purifying particulate respirators are classified into three series, N-, R-, and P-series. The N-series filters are restricted to use in those workplaces free of oil aerosols. The R- and P-series filters are intended for removal of any particulate that includes oil-based liquid particulates.

(c) Non-powered air-purifying particulate respirators are classified according to the efficiency level of the filter(s) as tested according to the requirements of this part.

(1) N100, R100, and P100 filters shall demonstrate a minimum efficiency level of 99.97 percent.

(2) N99, R99, and P99 filters shall demonstrate a minimum efficiency level of 99 percent.



(3) N95, R95, and P95 filters shall demonstrate a minimum efficiency level of 95 percent.

**§ 84.171 Non-powered air-purifying particulate respirators; required components.**

(a) Each non-powered air-purifying particulate respirator described in § 84.170 shall, where its design requires, contain the following component parts:

- (1) Facepiece, mouthpiece with noseclip, hood, or helmet;
- (2) Filter unit;
- (3) Harness;
- (4) Attached blower; and
- (5) Breathing tube.

(b) The components of each non-powered air-purifying particulate respirator shall meet the minimum construction requirements set forth in subpart G of this part.

**§ 84.172 Breathing tubes; minimum requirements.**

Flexible breathing tubes used in conjunction with respirators shall be designed and constructed to prevent:

- (a) Restriction of free head movement;
- (b) Disturbance of the fit of facepieces, mouthpieces, hoods, or helmets;
- (c) Interference with the wearer's activities; and
- (d) Shutoff of airflow due to kinking, or from chin or arm pressure.

**§ 84.173 Harnesses; installation and construction; minimum requirements.**

(a) Each respirator shall, where necessary, be equipped with a suitable harness designed and constructed to hold the components of the respirator in position against the wearer's body.

(b) Harnesses shall be designed and constructed to permit easy removal and replacement of respirator parts, and, where applicable, provide for holding a full facepiece in the ready position when not in use.

**§ 84.174 Respirator containers; minimum requirements.**

(a) Except as provided in paragraph (b) of this section each respirator shall be equipped with a substantial, durable container bearing markings which show the applicant's name, the type of respirator it contains, and all appropriate approval labels.

(b) Containers for single-use respirators may provide for storage of more than one respirator, however, such containers shall be designed and constructed to prevent contamination of respirators which are not removed, and to prevent damage to respirators during transit.

**§ 84.175 Half-mask facepieces, full facepieces, hoods, helmets, and mouthpieces; fit; minimum requirements.**

(a) Half-mask facepieces and full facepieces shall be designed and constructed to fit persons with various facial shapes and sizes either:

- (1) By providing more than one facepiece size; or
- (2) By providing one facepiece size which will fit varying facial shapes and sizes.

(b) Full facepieces shall provide for optional use of corrective spectacles or lenses, which shall not reduce the respiratory protective qualities of the respirator.

(c) Hoods and helmets shall be designed and constructed to fit persons with various head sizes, provide for the optional use of corrective spectacles or lenses, and insure against any restriction of movement by the wearer.

(d) Mouthpieces shall be equipped with noseclips which are securely attached to the mouthpiece or respirator and provide an airtight seal.

(e) Facepieces, hoods, and helmets shall be designed to prevent eyepiece fogging.

(f) Half-mask facepieces shall not interfere with the fit of common industrial safety corrective spectacles.

**§ 84.176 Facepieces, hoods, and helmets; eyepieces; minimum requirements.**

Facepieces, hoods, and helmets shall be designed and constructed to provide adequate vision which is not distorted by the eyepieces.

**§ 84.177 Inhalation and exhalation valves; minimum requirements.**

(a) Inhalation and exhalation valves shall be protected against distortion.

(b) Inhalation valves shall be designed and constructed and provided where necessary to prevent excessive exhaled air from adversely affecting filters, except where filters are specifically designed to resist moisture.

- (c) Exhalation valves shall be:
  - (1) Provided where necessary;
  - (2) Protected against damage and external influence; and
  - (3) Designed and constructed to prevent inward leakage of contaminated air.

(3) Designed and constructed to prevent inward leakage of contaminated air.

**§ 84.178 Head harnesses; minimum requirements.**

(a) All facepieces shall be equipped with head harnesses designed and constructed to provide adequate tension during use and an even distribution of pressure over the entire area in contact with the face.

(b) Facepiece head harnesses, except those employed on single-use respirators, shall be adjustable and replaceable.

(c) Mouthpieces shall be equipped, where applicable, with adjustable and replaceable harnesses, designed and constructed to hold the mouthpiece in place.

**§ 84.179 Non-powered air-purifying particulate respirators; filter identification.**

(a) The respirator manufacturer, as part of the application for certification, shall specify the filter series and the filter efficiency level (i.e., "N95", "R95", "P95", "N99", "R99", "P99", "N100", "R100", or "P100") for which certification is being sought.

(b) Filters shall be prominently labeled as follows:

(1) N100 filters shall be labeled "N100 Particulate Filter (99.97% filter efficiency level)" and shall be a color other than magenta.

(2) R100 filters shall be labeled "R100 Particulate Filter (99.97% filter efficiency level)" and shall be a color other than magenta.

(3) P100 filters shall be labeled "P100 Particulate Filter (99.97% filter efficiency level)" and shall be color coded magenta.

(4) N99 filters shall be labeled "N99 Particulate Filter (99% filter efficiency level)" and shall be a color other than magenta.

(5) R99 filters shall be labeled "R99 Particulate Filter (99% filter efficiency level)" and shall be a color other than magenta.

(6) P99 filters shall be labeled "P99 Particulate Filter (99% filter efficiency level)" and shall be a color other than magenta.

(7) N95 filters shall be labeled as "N95 Particulate Filter (95% filter efficiency level)" and shall be a color other than magenta.

(8) R95 filters shall be labeled as "R95 Particulate Filter (95% filter efficiency level)" and shall be a color other than magenta.

(9) P95 filters shall be labeled as "P95 Particulate Filter (95% filter efficiency level)" and shall be a color other than magenta.

**§ 84.180 Airflow resistance tests.**

(a) Resistance to airflow will be measured in the facepiece, mouthpiece, hood, or helmet of a particulate respirator (complete respirator) mounted on a test fixture with air flowing at continuous rate of 85±2 liters per minute, before each test conducted in accordance with § 84.182.

(b) The resistances for particulate respirators upon initial inhalation shall not exceed 35 mm water column height pressure and upon initial exhalation shall not exceed 25 mm water column height pressure.



**§ 84.181 Non-powered air-purifying particulate filter efficiency level determination.**

(a) Twenty filters of each non-powered air-purifying particulate respirator model shall be tested for filter efficiency against:

(1) A solid sodium chloride particulate aerosol as per this section, if N-series certification is requested by the applicant.

(2) A dioctyl phthalate or equivalent liquid particulate aerosol as per this section, if R-series or P-series certification is requested by the applicant.

(b) Filters including holders and gaskets; when separable, shall be tested for filter efficiency level, as mounted on a test fixture in the manner as used on the respirator.

(c) Prior to filter efficiency testing of 20 N-series filters, the 20 to be tested shall be taken out of their packaging and placed in an environment of 85±5 percent relative humidity at 38±2.5 °C for 25±1 hours. Following the pre-conditioning, filters shall be sealed in a gas-tight container and tested within 10 hours.

(d) When the filters do not have separable holders and gaskets, the exhalation valves shall be blocked so as to ensure that leakage, if present, is not included in the filter efficiency level evaluation.

(e) For non-powered air-purifying particulate respirators with a single filter, filters shall be tested at a continuous airflow rate of 85±4 liters per minute. Where filters are to be used in pairs, the test-aerosol airflow rate shall be 42.5±2 liters per minute through each filter.

(f) Filter efficiency test aerosols.

(1) When testing N-series filters, a sodium chloride or equivalent solid aerosol at 25±5 °C and relative humidity of 30±10 percent that has been neutralized to the Boltzmann equilibrium state shall be used. Each filter shall be challenged with a concentration not exceeding 200 mg/m<sup>3</sup>.

(2) When testing R-series and P-series filters, a neat cold-nebulized dioctyl phthalate (DOP) or equivalent aerosol at 25±5 °C that has been neutralized to the Boltzmann equilibrium state shall be used. Each filter shall be challenged with a concentration not exceeding 200 mg/m<sup>3</sup>.

(3) The test shall continue until minimum efficiency is achieved or until an aerosol mass of at least 200±5 mg has contacted the filter. For P-series filters, if the filter efficiency is decreasing when the 200±5 mg challenge point is reached, the test shall be continued

until there is no further decrease in efficiency.

(g) The sodium chloride test aerosol shall have a particle size distribution with count median diameter of 0.075±0.020 micrometer and a standard geometric deviation not exceeding 1.86 at the specified test conditions as determined with a scanning mobility particle sizer or equivalent. The DOP aerosol shall have a particle size distribution with count median diameter of 0.185±0.020 micrometer and a standard geometric deviation not exceeding 1.60 at the specified test conditions as determined with a scanning mobility particle sizer or equivalent.

(h) The efficiency of the filter shall be monitored and recorded throughout the test period by a suitable forward-light-scattering photometer or equivalent instrumentation.

(i) The minimum efficiency for each of the 20 filters shall be determined and recorded and be equal to or greater than the filter efficiency criterion listed for each level as follows:

P100, R100 and N100: Efficiency ≥99.97%  
 P99, R99 and N99: Efficiency ≥99%  
 P95, R95 and N95: Efficiency ≥95%

**§ 84.182 Exhalation valve leakage test; minimum requirements.**

(a) Dry exhalation valves and valve seats will be subjected to a suction of 25 mm. water-column height while in a normal operating position.

(b) Leakage between the valve and valve seat shall not exceed 30 milliliters per minute.

**Subpart L—Chemical Cartridge Respirators**

**§ 84.190 Chemical cartridge respirators: description.**

(a) Chemical cartridge respirators including all completely assembled respirators which are designed for use as respiratory protection during entry into or escape from atmospheres not immediately dangerous to life and health, are described according to the specific gases or vapors against which they are designed to provide respiratory protection, as follows:

Type of chemical cartridge respirator <sup>1</sup>	Maximum use concentration, parts per million
Ammonia .....	300
Chlorine .....	10
Hydrogen chloride .....	50
Methyl amine .....	100
Organic vapor .....	≥ 1,000
Sulfur dioxide .....	50

Type of chemical cartridge respirator <sup>1</sup>	Maximum use concentration, parts per million
Vinyl chloride .....	10

<sup>1</sup> Not for use against gases or vapors with poor warning properties (except where MSHA or Occupational Safety and Health Administration standards may permit such use for a specific gas or vapor) or those which generate high heats of reaction with sorbent material in the cartridge.

<sup>2</sup> Maximum use concentrations are lower for organic vapors which produce atmospheres immediately hazardous to life or health at concentrations equal to or lower than this concentration.

(b) Chemical cartridge respirators for respiratory protection against gases or vapors, which are not specifically listed with their maximum use concentration, may be approved if the applicant submits a request for such approval, in writing, to the Institute. The Institute shall consider each such application and accept or reject the application after a review of the effects on the wearer's health and safety and in the light of any field experience in use of chemical cartridge respirators as protection against such hazards.

**§ 84.191 Chemical cartridge respirators; required components.**

(a) Each chemical cartridge respirator described in § 84.190 shall, where its design requires, contain the following component parts:

- (1) Facepiece, mouthpiece, and noseclip, hood, or helmet;
- (2) Cartridge;
- (3) Cartridge with filter;
- (4) Harness;
- (5) Breathing tube; and
- (6) Attached blower.

(b) The components of each chemical cartridge respirator shall meet the minimum construction requirements set forth in subpart G of this part.

**§ 84.192 Cartridges in parallel; resistance requirements.**

Where two or more cartridges are used in parallel, their resistance to airflow shall be essentially equal.

**§ 84.193 Cartridges; color and markings; requirements.**

The color and markings of all cartridges or labels shall conform with the requirements of the American National Standards Institute, American National Standard for Identification of Air-Purifying Respirator Canisters and Cartridges, ANSI K13.1-1973. ANSI K13.1 is incorporated by reference and has been approved by the Director of the Federal Register in accordance with 5 U.S.C. 552(a) and 1 CFR part 51. Copies may be obtained from American



National Standards Institute, Inc., 1430 Broadway, New York, NY 10018. Copies may be inspected at the NIOSH, Certification and Quality Assurance Branch, 1095 Willowdale Road, Morgantown, WV 26505-2888, or at the Office of the Federal Register, 800 North Capitol Street, NW., suite 700, Washington, DC.

**§ 84.194 Filters used with chemical cartridges; location; replacement.**

- (a) Particulate matter filters used in conjunction with a chemical cartridge shall be located on the inlet side of the cartridge.
- (b) Filters shall be incorporated in or firmly attached to the cartridge and each filter assembly shall, where applicable, be designed to permit its easy removal from and replacement on the cartridge.

**§ 84.195 Breathing tubes; minimum requirements.**

- Flexible breathing tubes used in conjunction with respirators shall be designed and constructed to prevent:
- (a) Restriction of free head movement;
  - (b) Disturbance of the fit of facepieces, mouthpieces, hoods, or helmets;
  - (c) Interference with the wearer's activities; and
  - (d) Shutoff of airflow due to kinking, or from chin or arm pressure.

**§ 84.196 Harnesses; installation and construction; minimum requirements.**

- (a) Each respirator shall, where necessary, be equipped with a suitable harness designed and constructed to hold the components of the respirator in position against the wearer's body.
- (b) Harnesses shall be designed and constructed to permit easy removal and replacement of respirator parts and, where applicable, provide for holding a full facepiece in the ready position when not in use.

**§ 84.197 Respirator containers; minimum requirements.**

Respirators shall be equipped with a substantial, durable container bearing

markings which show the applicant's name, the type and commercial designation of the respirator it contains and all appropriate approval labels.

**§ 84.198 Half-mask facepieces, full facepieces, mouthpieces, hoods, and helmets; fit; minimum requirements.**

- (a) Half-mask facepieces and full facepieces shall be designed and constructed to fit persons with various facial shapes and sizes either:
  - (1) By providing more than one facepiece size; or
  - (2) By providing one facepiece size which will fit varying facial shapes and sizes.
- (b) Hoods and helmets shall be designed and constructed to fit persons with various head sizes, provide for the optional use of corrective spectacles or lenses, and insure against any restriction of movement by the wearer.
- (c) Mouthpieces shall be equipped with noseclips which are securely attached to the mouthpiece or respirator and provide an airtight fit.
- (d) Full facepieces shall provide for optional use of corrective spectacles or lenses which shall not reduce the respiratory protective qualities of the respirator.
- (e) Facepieces, hoods, and helmets shall be designed to prevent eyepiece fogging.

**§ 84.199 Facepieces, hoods, and helmets; eyepieces; minimum requirements.**

Facepieces, hoods, and helmets shall be designed and constructed to provide adequate vision which is not distorted by the eyepieces.

**§ 84.200 Inhalation and exhalation valves; minimum requirements.**

- (a) Inhalation and exhalation valves shall be provided where necessary and protected against distortion.
- (b) Inhalation valves shall be designed and constructed to prevent excessive exhaled air from entering cartridges or adversely affecting canisters.
- (c) Exhalation valves shall be—

- (1) Protected against damage and external influence; and
- (2) Designed and constructed to prevent inward leakage of contaminated air.

**§ 84.201 Head harnesses; minimum requirements.**

- (a) (1) Facepieces for chemical cartridge respirators other than single-use vinyl chloride shall be equipped with adjustable and replaceable head harnesses designed and constructed to provide adequate tension during use and an even distribution of pressure over the entire area in contact with the face.
- (2) Facepieces for single-use vinyl chloride respirators shall be equipped with adjustable head harnesses designed and constructed to provide adequate tension during use and an even distribution of pressure over the entire area in contact with the face.

(b) Mouthpieces shall be equipped where applicable, with an adjustable and replaceable harness designed and constructed to hold the mouthpiece in place.

**§ 84.202 Air velocity and noise levels; hoods and helmets; minimum requirements.**

Noise levels generated by the respirator will be measured inside the hood or helmet at maximum airflow obtainable and shall not exceed 80 dBA.

**§ 84.203 Breathing resistance test; minimum requirements.**

- (a) Resistance to airflow will be measured in the facepiece, mouthpiece, hood, or helmet of a chemical cartridge respirator mounted on a test fixture with air flowing at a continuous rate of 85 liters per minute, both before and after each test conducted in accordance with §§ 84.206 through 84.207.
- (b) The maximum allowable resistance requirements for chemical cartridge respirators are as follows:

MAXIMUM RESISTANCE  
[Millimeter water column height]

Type of chemical-cartridge respirator	Inhalation		Exhalation
	Initial	Final <sup>1</sup>	
Other than single-use vinyl chloride respirators:			
For gases, vapors, or gases and vapors .....	40	45	20
For gases, vapors, or gases and vapors, and particulates .....	50	70	20
Single-use respirator with valves:			
For vinyl chloride .....	20	25	20
For vinyl chloride and particulates .....	30	45	2
Single-use respirator without valves:			
For vinyl chloride .....	15	20	( <sup>2</sup> )
For vinyl chloride and particulates .....	25	40	( <sup>2</sup> )

<sup>1</sup> Measured at end of service life specified in Table 11 of this subpart.



<sup>2</sup> Same as inhalation.

**§ 84.204 Exhalation valve leakage test; minimum requirements.**

(a) Dry exhalation valves and valve seats will be subjected to a suction of 25 mm. water-column height while in a normal operating position.

(b) Leakage between the valve and valve seat shall not exceed 30 milliliters per minute.

**§ 84.205 Facepiece test; minimum requirements.**

(a) The complete chemical cartridge respirator will be fitted to the faces of persons having varying facial shapes and sizes.

(b) Where the applicant specifies a facepiece size or sizes for the respirator together with the approximate measurement of faces they are designed to fit, the Institute will provide test subjects to suit such facial measurements.

(c) Any chemical cartridge respirator part which must be removed to perform the facepiece or mouthpiece fit test shall be replaceable without special tools and without disturbing facepiece or mouthpiece fit.

(d) The facepiece or mouthpiece fit test using the positive or negative pressure recommended by the applicant and described in his instructions will be used before each test.

(e) (1) Each wearer will enter a chamber containing 100 p.p.m. isoamyl acetate vapor for half-mask facepieces, and 1,000 p.p.m. for full facepieces, mouthpieces, hoods, and helmets.

(2) The facepiece or mouthpiece may be adjusted, if necessary, in the test chamber before starting the test.

(3) Each wearer will remain in the chamber for 8 minutes while performing the following activities:

(i) Two minutes, nodding and turning head;

(ii) Two minutes, calisthenic arm movements;

(iii) Two minutes, running in place; and

(iv) Two minutes, pumping with a tire pump into a 28-liter (1 cubic-foot) container.

(4) Each wearer shall not detect the odor of isoamyl-acetate vapor during the test.

**§ 84.206 Particulate tests; respirators with filters; minimum requirements; general.**

(a) Three respirators with cartridges containing, or having attached to them, filters for protection against particulates will be tested in accordance with the provisions of § 84.207.

(b) In addition to the test requirements set forth in paragraph (a) of this section, three such respirators will be tested, as appropriate, in accordance with the provisions of §§ 84.179 through 84.183; however, the maximum allowable resistance of complete particulate, and gas, vapor, or gas and vapor chemical cartridge respirators shall not exceed the maximum allowable limits set forth in § 84.203.

**§ 84.207 Bench tests; gas and vapor tests; minimum requirements; general.**

(a) Bench tests will be made on an apparatus that allows the test atmosphere at 50±5 percent relative humidity and room temperature,

approximately 25 °C, to enter the cartridges continuously at predetermined concentrations and rates of flow, and that has means for determining the test life of the cartridges.

(b) Where two cartridges are used in parallel on a chemical cartridge respirator, the bench test will be performed with the cartridges arranged in parallel, and the test requirements will apply to the combination rather than to the individual cartridges.

(c) Three cartridges or pairs of cartridges will be removed from containers and tested as received from the applicant.

(d) Two air purifying cartridges or pairs of cartridges will be equilibrated at room temperature by passing 25 percent relative humidity air through them at the flow rate of 25 liters per minute (l.p.m.) for 6 hours.

(e) Two air purifying cartridges or pairs of cartridges will be equilibrated by passing 85 percent relative humidity air through them at the flow rate of 25 l.p.m.

(f) All cartridges will be resealed, kept in an upright position, at room temperatures, and tested within 18 hours.

(g) Cartridges will be tested and shall meet the minimum requirements set forth in Table 11 of this subpart.

**Tables to Subpart L of Part 84**

**TABLES 9 AND 10 [RESERVED]**

**TABLE 11—CARTRIDGE BENCH TESTS AND REQUIREMENTS**

[42 CFR part 84, subpart L]

Cartridge	Test condition	Test atmosphere		Flowrate (l.p.m.)	Number of tests	Penetration <sup>1</sup> (p.p.m.)	Minimum life <sup>2</sup> (min.)
		Gas or vapor	Concentration (p.p.m.)				
Ammonia .....	As received .....	NH <sub>3</sub>	1000	64	3	50	50
Ammonia .....	Equilibrated .....	NH <sub>3</sub>	1000	32	4	50	50
Chlorine .....	As received .....	Cl <sub>2</sub>	500	64	3	5	35
Chlorine .....	Equilibrated .....	Cl <sub>2</sub>	500	32	4	5	35
Hydrogen chloride .....	As received .....	HCl	500	64	3	5	50
Hydrogen chloride .....	Equilibrated .....	HCl	500	32	4	5	50
Methylamine .....	As received .....	CH <sub>3</sub> NH <sub>2</sub>	1000	64	3	10	25
Methylamine .....	Equilibrated .....	CH <sub>3</sub> NH <sub>2</sub>	1000	32	4	10	25
Organic vapors .....	As received .....	CCl <sub>4</sub>	1000	64	3	5	50
Organic vapors .....	Equilibrated .....	CCl <sub>4</sub>	1000	32	4	5	50
Sulfur dioxide .....	As received .....	SO <sub>2</sub>	500	64	3	5	30
Sulfur dioxide .....	Equilibrated .....	SO <sub>2</sub>	500	32	4	5	30

<sup>1</sup> Minimum life will be determined at the indicated penetration.



<sup>2</sup> Where a respirator is designed for respiratory protection against more than one type of gas or vapor, as for use in ammonia and in chlorine, the minimum life shall be one-half that shown for each type of gas or vapor. Where a respirator is designed for respiratory protection against more than one gas of a type, as for use in chlorine and sulfur dioxide, the stated minimal life shall apply.

#### Subpart M—[Reserved]

#### Subpart N—Special Use Respirators

##### § 84.250 Vinyl chloride respirators; description.

Vinyl chloride respirators, including all completely assembled respirators which are designed for use as respiratory protection during entry into and escape from vinyl chloride atmospheres containing adequate oxygen to support life, are described according to their construction as follows:

- (a) Front-mounted or back-mounted gas masks;
- (b) Chin-style gas masks;
- (c) Chemical-cartridge respirators;
- (d) Powered air-purifying respirators; and
- (e) Other devices, including combination respirators.

##### § 84.251 Required components.

(a) Each vinyl chloride respirator described in § 84.250 shall, where its design requires, contain the following component parts:

- (1) Facepiece;
- (2) Canister with end-of-service-life indicator;
- (3) Cartridge with end-of-service-life indicator;
- (4) Harness;
- (5) Attached blower; and
- (6) Breathing tube.

(b) The components of each vinyl chloride respirator shall meet the minimum construction requirements set forth in Subpart G of this part.

##### § 84.252 Gas masks; requirements and tests.

(a) Except for the tests prescribed in § 84.126, the minimum requirements and performance tests for gas masks, prescribed in Subpart I of this part, are applicable to vinyl chloride gas masks.

(b) The following bench tests are applicable to canisters designed for use with gas masks for entry into and escape from vinyl chloride atmospheres containing adequate oxygen to support life:

- (1) Four canisters will be equilibrated at  $25\pm 5$  °C by passing  $85\pm 5$  percent relative humidity air through them at 64 liters per minute for six hours.
- (2) The equilibrated canisters will be resealed, kept in an upright position at room temperature, and tested according to paragraph (b)(3) of this section within 18 hours.
- (3) The canisters equilibrated and stored as described in paragraphs (b) (1)

and (2) of this section will be tested on an apparatus that allows the test atmosphere at  $85\pm 5$  percent relative humidity and  $25\pm 5$  °C to enter the canister continuously at a concentration of 25 ppm vinyl chloride monomer at a total flow rate of 64 liters per minute.

(4) The maximum allowable penetration after six hours of testing according to paragraph (b)(3) of this section shall not exceed 1 ppm vinyl chloride.

(c) Where canisters are submitted for testing and approval with a service life of more than four hours, the period of time for testing for vinyl chloride penetration will be performed at 150% of the service life specified in the manufacturer's application. (Example: If a manufacturer requests approval of a respirator for six hours use against exposure to vinyl chloride, the maximum allowable penetration after nine hours of testing shall not exceed 1 ppm vinyl chloride.)

##### § 84.253 Chemical-cartridge respirators; requirements and tests.

(a) Except for the tests prescribed in §§ 84.206 and 84.207, the minimum requirements and performance tests for chemical-cartridge respirators prescribed in Subpart L of this part are applicable to replaceable-cartridge and single-use vinyl chloride chemical-cartridge respirators.

(b) The following bench tests are applicable to cartridges designed for use with chemical-cartridge respirators for entry into and escape from vinyl chloride atmospheres containing adequate oxygen to support life:

- (1) Where two cartridges are used in parallel on a chemical-cartridge respirator, the bench test requirements will apply to the combination rather than the individual cartridges.
- (2) Four cartridges or pairs of cartridges will be equilibrated at  $25\pm 5$  °C by passing  $85\pm 5$  percent relative humidity air through them at 25 liters per minute for six hours.
- (3) The equilibrated cartridges will be resealed, kept in an upright position, at room temperature, and tested according to paragraphs (b)(4) and (b)(5) of this section for other than single-use respirators or according to paragraphs (b)(6) and (b)(7) of this section for single-use respirators within 18 hours.
- (4) The cartridges or pairs of cartridges for other than single-use respirators, equilibrated and stored as described in paragraphs (b)(1), (b)(2), and (b)(3) of this section, will be tested

on an apparatus that allows the test atmosphere at  $85\pm 5$  percent relative humidity and  $25\pm 5$  °C, to enter the cartridges or pairs of cartridges continuously at a concentration of 10 ppm vinyl chloride monomer at a total flowrate of 64 liters per minute.

(5) The maximum allowable penetration after 90 minutes testing of cartridges or pairs of cartridges for other than single-use respirators, according to paragraph (b)(4) of this section shall not exceed 1 ppm vinyl chloride.

(6) The single-use respirators, equilibrated and stored as described in paragraphs (b)(2) and (b)(3) of this section, will be tested on an apparatus that allows a test atmosphere at  $85\pm 5$  percent relative humidity and  $25\pm 5$  °C to be cycled through the respirator by a breathing machine at a concentration of 10 ppm vinyl chloride monomer at the rate of 24 respirations per minute at a minute volume of  $40\pm 0.6$  liters. Air exhaled through the respirator will be  $35\pm 2$  °C with  $94\pm 3$  percent relative humidity.

(7) The maximum allowable penetration after 144 minutes testing of respirators, according to paragraph (b)(6) of this section, shall not exceed 1 ppm vinyl chloride.

##### § 84.254 Powered air-purifying respirators; requirements and tests.

(a) Except for the tests prescribed in § 84.207, the minimum requirements and performance tests for powered air-purifying respirators prescribed in subpart L of this part are applicable to vinyl chloride powered air-purifying respirators.

(b) The following bench tests are applicable to cartridges designed for use with powered air-purifying respirators for entry into and escape from vinyl chloride atmospheres containing adequate oxygen to support life:

- (1) Four cartridges will be equilibrated at  $25\pm 5$  °C by passing  $85\pm 5$  percent relative humidity air through them at 115 liters per minute for tight-fitting facepieces and 170 liters per minute for loose-fitting hoods and helmets, for six hours.
- (2) The equilibrated cartridges will be resealed, kept in an upright position at room temperature and tested according to paragraph (b)(3) of this section within 18 hours.
- (3) The cartridges equilibrated and stored as described in paragraphs (b) (1) and (2) of this section will be tested on an apparatus that allows the test atmosphere at  $85\pm 5$  percent relative



humidity and 25±5 °C to enter the cartridge continuously at a concentration of 25 ppm vinyl chloride monomer at a total flow rate of 115 liters per minute for tight-fitting facepieces and 170 liters per minute for loose-fitting hoods and helmets.

(4) The maximum allowable penetration after six hours of testing according to paragraph (b)(3) of this section shall not exceed 1 ppm vinyl chloride.

**§ 84.255 Requirements for end-of-service-life indicator.**

(a) Each canister or cartridge submitted for testing and approval in accordance with §§ 84.252, 84.253, and 84.254 shall be equipped with a canister or cartridge end-of-service-life indicator which shows a satisfactory indicator change or other obvious warning before 1 ppm vinyl chloride penetration occurs. The indicator shall show such change or afford such warning at 80±10 percent of the total service life to 1 ppm leakage, as determined by continuing each test described in §§ 84.252(b), 84.253(b), and 84.254(b) until a 1 ppm leakage of vinyl chloride occurs.

(b) The applicant shall provide sufficient pretest data to verify the performance of the end-of-service-life indicator required in paragraph (a) of this section.

**§ 84.256 Quality control requirements.**

(a) In addition to the construction and performance requirements specified in §§ 84.251, 84.252, 84.253, 84.254, and 84.255, the quality control requirements in paragraphs (b), (c), and (d) of this section apply to approval of gas masks, chemical cartridge respirators, and powered air-purifying respirators for entry into and escape from vinyl chloride atmospheres containing adequate oxygen to support life.

(b) The respirators submitted for approval as described in paragraph (a) of this section shall be accompanied by a complete quality control plan meeting the requirements of subpart E of this part.

(c) (1) The applicant shall specify in the plan that a sufficient number of samples will be drawn from each bulk container of sorbent material and that where activated carbon is used, the following specific tests will be performed:

- (i) Apparent density;
- (ii) Iodine number;
- (iii) Moisture content;
- (iv) Carbon tetrachloride number; and
- (v) Mesh size.

(2) The tests in paragraph (c)(1) of this section shall be performed in a quantity necessary to assure continued

satisfactory conformance of the canisters and cartridges to the requirements of this subpart.

(d) Final performance quality control tests on the complete canisters and cartridges shall be accomplished using the bench tests and procedures prescribed in §§ 84.252, 84.253, 84.254, and 84.255.

**§ 84.257 Labeling requirements.**

(a) A warning shall be placed on the label of each gas mask, chemical-cartridge respirator, and powered air-purifying respirator, and on the label of each canister and cartridge, alerting the wearer to the need for a fitting test in accordance with the manufacturer's facepiece fitting instructions, providing service life information, providing specific instructions for disposal, and advising that the wearer may communicate to NIOSH any difficulties that may be experienced in the design and performance of any gas mask, chemical-cartridge respirator, or powered air-purifying respirator approved under the requirements of this subpart. The service lives of respirators meeting the test requirements of this subpart shall be specified as follows:

Chemical-cartridge respirator .....	1 hour.
Gas mask .....	4 hours.
Powered air-purifying respirator .....	4 hours.

(b) Where the service life of a respirator is approved for more than four hours, the service life for which the respirator has been approved will be specified.

**§ 84.258 Fees.**

The following fees shall be charged for the examination, inspection, and testing of complete assemblies and components of respirators described in §§ 84.250 and 84.251:

Complete gas mask.....	\$1,100
Complete chemical-cartridge respirator.....	1,150
Complete powered air-purifying respirator.....	1,500
Canister or cartridge only.....	750

**Subparts O through JJ [Reserved]**

**Subpart KK—Dust, Fume, and Mist; Pesticide; Paint Spray; Powered Air-Purifying High Efficiency Respirators and Combination Gas Masks**

**§ 84.1100 Scope and effective dates.**

The purpose of this subpart KK is to establish procedures and requirements for issuing extensions of approval of particulate respirators certified prior to July 10, 1995 under the provisions of 30 CFR part 11 (See 30 CFR part 11 edition, as revised July 1, 1994.), new approvals and extensions of approval of

particulate respirators for applications that are in NIOSH receipt on July 10, 1995, and approval of powered air-purifying respirators.

(a) Air-purifying respirators with particulate filters approved under the provisions of this subpart after July 10, 1995 will have a 30 CFR part 11 approval label.

(b) Only changes or modifications of non-powered air-purifying respirators with particulate filters approved under the provisions of subparts I, K, L, or M of 30 CFR part 11 or paragraph (a) of this section and deemed necessary by NIOSH to ensure the health and safety of the wearer will be approved until July 10, 1998 and will have a 30 CFR part 11 approval label.

(c) Only changes or modifications of powered air-purifying respirators with particulate filters approved under the provisions of subparts I, K, L, or M of 30 CFR part 11 or paragraph (a) of this section and deemed necessary by NIOSH to ensure the health and safety of the wearer will be approved under this subpart until July 10, 1998 and will have a 30 CFR part 11 label.

(d) Approval of powered air-purifying respirators will be issued under this subpart. Particulate filters for powered air-purifying respirators approved under the provisions of this subpart shall be only high-efficiency (HEPA) as described in § 84.1130(a)(4) and will carry a 42 CFR part 84 approval label. In addition, changes or modifications of powered HEPA air-purifying respirators approved under the provisions of this subpart KK will be approved under this subpart and will have a 42 CFR part 84 approval label.

**§ 84.1101 Definitions.**

As used in this subpart  
 (a) *Air Contamination Level* means the standards of contaminant levels prescribed by the Secretary of Labor in accordance with the provisions of the Occupational Safety and Health Act of 1970 (Pub. L. 91-596; 84 Stat. 1590).

(b) *DOP* means a homogenous liquid aerosol, having a particle diameter of 0.3 micrometer, which is generated by vaporization and condensation of dioctyl phthalate.

(c) *Pesticide* means:

(1) Any substance or mixture of substances (including solvents and impurities) intended to prevent, destroy, repel, or mitigate any insect, rodent, nematode, fungus, weed, or other form of plant or animal life or virus; and

(2) Any substance or mixture of substances (including solvents and impurities) intended for use as a plant regulator, defoliant, or desiccant, as defined in the Federal Insecticide,



Fungicide, and Rodenticide Act of 1947, as amended (7 U.S.C. 135-135k), excluding fumigants which are applied as gases or vapors or in a solid or liquid form as pellets or poured liquids for subsequent release as gases or vapors.

(d) *Radionuclide* means an atom identified by the constitution of its nucleus (specified by the number of protons Z, number of neutrons N, and energy, or, alternatively, by the atomic number Z, mass number A=(N+Z), and atomic mass) which exists for a measurable time; decays or disintegrates spontaneously, emits radiation, and results in the formation of new nuclides.

(e) *Smoke* means the products of incomplete combustion of organic substances in the form of solid and liquid particles and gaseous products in air, usually of sufficient concentration to perceptibly obscure vision.

**§ 84.1102 Examination, inspection and testing of complete respirator assemblies; fees.**

The following fees shall be charged by the Institute for the examination, inspection and testing of complete respirator assemblies approved under this subpart:

- (a) Gas masks with particulate filter, including pesticide gas masks—
  - (1) Single hazard—\$1,100.
  - (2) Type N—\$4,100.
- (b) Dust, fume and mist respirators—
  - (1) Single particulate hazard having an Air Contamination Level more than 0.05 mg./m.<sup>3</sup> or 2 million particles per cubic foot—\$500.

(2) Combination particulate hazards having an Air Contamination Level more than 0.05 mg./m.<sup>3</sup> or 2 million particles per cubic foot—\$750.

(3) Particulate hazards having an Air Contamination Level less than 0.05 mg./m.<sup>3</sup> or 2 million particles per cubic foot, radon daughters —\$1,250.

(4) All dusts, fumes and mists—\$2,000.

(c) Paint spray respirators—\$1,600.

(d) Pesticide respirators—\$1,600.

(e) Chemical cartridge respirators with particulate filter—\$1,150.

**§ 84.1103 Approval labels and markings; approval of contents; use.**

(a) Full-scale reproductions of approval labels and markings, and a sketch or description of the method of application and position on the harness, container, canister, cartridge, filter, or other component, together with instructions for the use and maintenance of the respirator shall be submitted to MSHA and the Institute for approval.

(b) Approval labels for non-powered and powered air-purifying dust, fume, mist respirators approved prior to July 10, 1995 under the provisions of subpart K of 30 CFR part 11 (See 30 CFR Part 11 edition, revised as of July 1, 1994.) shall bear the emblem of the Mine Safety and Health Administration and the seal of the Department of Health and Human Services, the applicant's name and address, an approval number assigned by the Institute, a statement

that the respirator was tested and approved under subpart K of 30 CFR part 11 and, where appropriate, restrictions or limitations placed upon the use of the respirator by the Institute. The approval number assigned by the Institute shall be designated by the prefix TC and a serial number.

(c) Approval labels for powered air-purifying respirators approved under the provisions of this subpart shall bear the emblem of the National Institute for Occupational Safety and Health and the seal of the Department of Health and Human Services, the applicant's name and address, an approval number assigned by the Institute, a statement stating the respirator was tested under the provisions of this subpart, and, where appropriate, restrictions or limitations placed upon the use of the respirator by the Institute. The approval number assigned by the Institute shall be designated by the prefix TC and a serial number.

(c) The Institute shall, where necessary, notify the applicant when additional labels, markings, or instructions will be required.

(d) Approval labels and markings shall only be used by the applicant to whom they were issued.

(e) Legible reproductions or abbreviated forms of the label approved by the Institute for use on each respirator shall be attached to or printed at the following locations:

Respirator type	Label type	Location
Gas mask with a particulate filter, including pesticide gas mask.	Entire .....	Mask and container.
Dust, fume, and mist respirators .....	Entire .....	Respirator container and filter container.
	Abbreviated .....	Filters.
Chemical-cartridge respirator with a particulate filter, including paint spray respirator.	Entire .....	Respirator container, cartridge container, and filter containers (where applicable).
	Abbreviated .....	Cartridges and filters and filter containers.
Pesticide respirator .....	Entire .....	Respirator container, and cartridge and filter containers.
	Abbreviated .....	Cartridges and filters.

(f) The use of any MSHA and Institute approval label obligates the applicant to whom it is issued to maintain or cause to be maintained the approved quality control sampling schedule and the acceptable quality level for each characteristic tested, and to assure that it is manufactured according to the drawings and specifications upon which the certificate of approval is based.

(g) Each respirator, respirator component, and respirator container shall, as required by the Institute to assure quality control and proper use of the respirator, be labeled distinctly to show the name of the applicant, and the

name and letters or numbers by which the respirator or respirator component is designated for trade purposes, and the lot number, serial number, or approximate date of manufacture.

**§ 84.1130 Respirators; description.**

(a) Dust, fume, and mist respirators, including all completely assembled respirators designed for use as respiratory protection during entry into and escape from atmospheres which contain adequate oxygen to support life and hazardous particulates, are described as follows:

(1) Air-purifying respirators, either with replaceable or reusable filters, designed as respiratory protection against dusts:

(i) Having an air contamination level not less than 0.05 milligram per cubic meter of air, including but not limited to coal, arsenic, cadmium, chromium, lead, and manganese; or

(ii) Having an air contamination level not less than 2 million particles per cubic foot of air, including but not limited to aluminum, flour, iron ore, and free silica, resulting principally from the disintegration of a solid, e.g., dust clouds produced in mining,



quarrying, and tunneling, and in dusts produced during industrial operations, such as grinding, crushing, and the general processing of minerals and other materials.

(2) Air-purifying respirators, with replaceable filters, designed as respiratory protection against fumes of various metals having an air contamination level not less than 0.05 milligram per cubic meter, including but not limited to aluminum, antimony, arsenic, cadmium, chromium, copper, iron, lead, magnesium, manganese, mercury (except mercury vapor), and zinc, which result from the sublimation or condensation of their respective vapors, or from the chemical reaction between their respective vapors and gases.

(3) Air-purifying respirators, with replaceable filters, designed as respiratory protection against mists of materials having an air contamination level not less than 0.05 milligram per cubic foot, e.g., mists produced by spray coating with vitreous enamels, chromic acid mist produced during chromium plating, and other mists of materials whose liquid vehicle does not produce harmful gases or vapors.

(4) Air-purifying respirators, with replaceable filters, designed as respiratory protection against dusts, fumes, and mists having an air contamination level less than 0.05 milligram per cubic meter, including but not limited to lithium hydride and beryllium, and against radionuclides.

(5) Air-purifying respirators, with replaceable filters, designed as respiratory protection against radon daughters, and radon daughters attached to dusts, fumes, and mists.

(6) Air-purifying respirators, with replaceable filters, designed as respiratory protection against asbestos-containing dusts and mists.

(7) Air-purifying respirators, with replaceable filters, designed as protection against various combinations of particulate matter.

(8) Air-purifying dust respirators designed as respiratory protection against pneumoconiosis- and fibrosis-producing dusts, or dusts and mists, including but not limited to aluminum, asbestos, coal, flour, iron ore, and free silica.

(b) Gas masks containing filters for protection against dusts, fumes, mists, and smokes in combination with gases, vapors, or gases and vapors. These respirators are not for use against gases or vapors with poor warning properties (except where MSHA or Occupational Safety and Health Administration standards may permit such use for a

specific gas or vapor) or those which generate high heats of reaction with sorbent material in the canister.

(c) Pesticide respirators, including all completely assembled respirators which are designed for use as respiratory protection during entry into and escape from atmospheres which contain pesticide hazards, are described according to their construction as follows:

(1) Front-mounted or back-mounted gas masks;

(2) Chin-style gas mask;

(3) Chemical cartridge;

(4) Air-purifying respirator with attached blower; and,

(5) Other devices, including combination respirators.

(d) Respirators with cartridges containing or having attached to them, filters for protection against mists of paints, lacquers, and enamels. These respirators are not for use against gases or vapors with poor warning properties (except where MSHA or Occupational Safety and Health Administration standards may permit such use for a specific gas or vapor) or those which generate high heats of reaction with sorbent material in the cartridge.

(e) Respirators with cartridges containing or having attached to them filters for protection against dusts, fumes, and mists, except the mists of paints, lacquers, and enamels. These respirators are not for use against gases or vapors with poor warning properties (except where MSHA or Occupational Safety and Health Administration standards may permit such use for a specific gas or vapor) or those which generate high heats of reaction with sorbent material in the cartridge.

**§ 84.1131 Respirators; required components.**

(a) Each respirator described in § 84.1130 shall, where its design requires, contain the following component parts:

(1) Facepiece, mouthpiece with noseclip, hood, or helmet;

(2) Filter unit, canister with filter, or cartridge with filter;

(3) Harness;

(4) Attached blower; and

(5) Breathing tube.

(b) The components of each respirator shall meet the minimum construction requirements set forth in Subpart G of this part.

**§ 84.1132 Breathing tubes; minimum requirements.**

(a) Flexible breathing tubes used in conjunction with respirators shall be designed and constructed to prevent:

(1) Restriction of free head movement;

(2) Disturbance of the fit of facepieces, mouthpieces, hoods, or helmets;

(3) Interference with the wearer's activities; and

(4) Shutoff of airflow due to kinking, or from chin or arm pressure.

**§ 84.1133 Harnesses; installation and construction; minimum requirements.**

(a) Each respirator shall, where necessary, be equipped with a suitable harness designed and constructed to hold the components of the respirator in position against the wearer's body.

(b) Harnesses shall be designed and constructed to permit easy removal and replacement of respirator parts, and, where applicable, provide for holding a full facepiece in the ready position when not in use.

**§ 84.1134 Respirator containers; minimum requirements.**

(a) Except as provided in paragraph (b) of this section each respirator shall be equipped with a substantial, durable container bearing markings which show the applicant's name, the type of respirator it contains, and all appropriate approval labels. Except for dust, fume, and mist respirators, the commercial designation of the respirator it contains shall be shown.

(b) Containers for single-use respirators may provide for storage of more than one respirator, however, such containers shall be designed and constructed to prevent contamination of respirators which are not removed, and to prevent damage to respirators during transit.

(c) Containers for gas masks combinations shall be designed and constructed to permit easy removal of the mask.

**§ 84.1135 Half-mask facepieces, full facepieces, hoods, helmets, and mouthpieces; fit; minimum requirements.**

(a) Half-mask facepieces and full facepieces shall be designed and constructed to fit persons with various facial shapes and sizes either:

(1) By providing more than one facepiece size; or

(2) By providing one facepiece size which will fit varying facial shapes and sizes.

(b) Full facepieces shall provide for optional use of corrective spectacles or lenses, which shall not reduce the respiratory protective qualities of the respirator.

(c) Hoods and helmets shall be designed and constructed to fit persons with various head sizes, provide for the optional use of corrective spectacles or lenses, and insure against any restriction of movement by the wearer.



(d) Mouthpieces shall be equipped with noseclips which are securely attached to the mouthpiece or respirator and provide an airtight seal.

(e) Facepieces, hoods, and helmets shall be designed to prevent eyepiece fogging.

(f) Half-mask facepieces shall not interfere with the fit of common industrial safety corrective spectacles, as determined by the Institute's facepiece tests in §§ 84.1141, 84.1142, and 84.1156(b).

**§ 84.1136 Facepieces, hoods, and helmets; eyepieces; minimum requirements.**

(a) Facepieces, hoods, and helmets shall be designed and constructed to provide adequate vision which is not distorted by the eyepieces.

(b) All eyepieces of gas masks combinations shall be designed and constructed to be impact and penetration resistant. Federal Specification, Mask, Air Line: and Respirator, Air Filtering, Industrial, GGG-M-125d, October 11, 1965, with interim amendment-1, July 30, 1969, is an example of an appropriate standard for determining impact and penetration resistance. Copies of GGG-M-125d may be obtained from the NIOSH, Certification and Quality Assurance Branch, 1095 Willowdale Road, Morgantown, WV 26505-2888.

**§ 84.1137 Inhalation and exhalation valves; minimum requirements.**

(a) Inhalation and exhalation valves shall be protected against distortion.

(b) Inhalation valves shall be designed and constructed and provided where necessary to prevent excessive exhaled air from adversely affecting filters, cartridges, and canisters, except where filters of dust, fume, and mist respirators are specifically designed to resist moisture as prescribed in § 84.1145.

(c) Exhalation valves shall be:

- (1) Provided where necessary;
- (2) Protected against damage and external influence; and
- (3) Designed and constructed to prevent inward leakage of contaminated air.

**§ 84.1138 Head harnesses; minimum requirements.**

(a) All facepieces shall be equipped with head harnesses designed and constructed to provide adequate tension during use and an even distribution of pressure over the entire area in contact with the face.

(b) Facepiece head harnesses, except those employed on single-use dust, fume, and mist respirators, shall be adjustable and replaceable.

(c) Mouthpieces shall be equipped, where applicable, with adjustable and replaceable harnesses, designed and constructed to hold the mouthpiece in place.

**§ 84.1139 Air velocity and noise levels; hoods and helmets; minimum requirements.**

Noise levels generated by the respirator will be measured inside the hood or helmet at maximum airflow obtainable and shall not exceed 80 dBA.

**§ 84.1140 Dust, fume, and mist respirators; performance requirements; general.**

Dust, fume, and mist respirators and the individual components of each such device shall, as appropriate, meet the requirements for performance and protection specified in the tests described in §§ 84.1141 through 84.1152 and prescribed in Tables 12 and 13.

**§ 84.1141 Isoamyl acetate tightness test; dust, fume, and mist respirators designed for respiratory protection against fumes of various metals having an air contamination level not less than 0.05 milligram per cubic meter; minimum requirements.**

(a) The respirator will be modified in such a manner that all of the air that normally would be inhaled through the inhalation port(s) is drawn through an efficient activated charcoal-filled canister, or cartridge(s), without interference with the face-contacting portion of the facepiece.

(b) The modified respirator will be worn by persons for at least 2 minutes each in a test chamber containing 100 parts (by volume) of isoamyl-acetate vapor per million parts of air.

(c) The odor of isoamyl-acetate shall not be detected by the wearers of the modified respirator while in the test atmosphere.

**§ 84.1142 Isoamyl acetate tightness test; respirators designed for respiratory protection against dusts, fumes, and mists having an air contamination level less than 0.05 milligram per cubic meter, or against radionuclides; minimum requirements.**

(a) The applicant shall provide a charcoal-filled canister or cartridge of a size and resistance similar to the filter unit with connectors which can be attached to the facepiece in the same manner as the filter unit.

(b)(1) The canister or cartridge will be used in place of the filter unit, and persons will each wear a modified half-mask facepiece for 5 minutes in a test chamber containing 100 parts (by volume) of isoamyl-acetate vapor per million parts of air.

(2) The following work schedule will be performed by each wearer in the test chamber:

(i) Two minutes walking, nodding, and shaking head in normal movements; and

(ii) Three minutes exercising and running in place.

(3) The facepiece shall be capable of adjustment, according to the applicant's instructions, to each wearer's face, and the odor of isoamyl-acetate shall not be detectable by any wearer during the test.

(c) Where the respirator is equipped with a full facepiece, hood, helmet, or mouthpiece, the canister or cartridge will be used in place of the filter unit, and persons will each wear the modified respiratory-inlet covering for 5 minutes in a test chamber containing 1,000 parts (by volume) of isoamyl-acetate vapor per million parts of air, performing the work schedule specified in paragraph (b)(2) of this section.

**§ 84.1143 Dust, fume, and mist air-purifying filter tests; performance requirements; general.**

Dust, fume, and mist respirators will be tested in accordance with the schedule set forth in Table 13 of this subpart to determine their effectiveness as protection against the particulate hazards specified in Table 13.

**§ 84.1144 Silica dust test for dust, fume, and mist respirators; single-use or reusable filters; minimum requirements.**

(a) Three non-powered respirators with single-use filters will be tested for periods of 90 minutes each at a continuous airflow rate of 32 liters per minute.

(b) The relative humidity in the test chamber will be 20-80 percent, and the room temperature approximately 25° C.

(c) The test suspension in the chamber will not be less than 50 nor more than 60 milligrams of flint (99+ percent free silica) per cubic meter of air.

(d) The flint in suspension will be ground to pass 99+ percent through a 270-mesh sieve.

(e) The particle-size distribution of the test suspension will have a geometric mean of 0.4 to 0.6 micrometer, and the standard geometric deviation will not exceed 2.

(f) The total amount of unretained test suspension in samples taken during testing shall not exceed 1.5 milligrams for a non-powered air-purifying respirator.

(g) Three non-powered respirators with reusable filters will be tested and shall meet the requirements specified in paragraphs (a) through (f) of this section; each filter shall be tested three times: Once as received; once after cleaning; and once after recleaning. The applicant's instructions shall be followed for each cleaning.



**§ 84.1145 Silica dust test; non-powered single-use dust respirators; minimum requirements.**

(a) Three respirators will be tested.  
 (b) As described in § 84.1144, airflow will be cycled through the respirator by a breathing machine at the rate of 24 respirations per minute with a minute volume of 40 liters; a breathing machine cam with a work rate of 622 kg.-m./minute shall be used.

(c) Air exhaled through the respirator will be 35° ±2° C. with 94 ±3 percent relative humidity. #

(d) Air inhaled through the respirator will be sampled and analyzed for respirator leakage.

(e) The total amount of unretained test suspension, after drying, in samples taken during testing, shall not exceed 1.8 milligrams for any single test.

**§ 84.1146 Lead fume test for dust, fume, and mist respirators; minimum requirements.**

(a) Three non-powered respirators will be tested for a period of 312 minutes each at a continuous airflow rate of 32 liters per minute.

(b) The relative humidity in the test chamber will be 20-80 percent, and the room temperature approximately 25° C.

(c) The test suspension in the test chamber will not be less than 15 nor more than 20 milligrams of freshly

generated lead-oxide fume, calculated as lead (Pb), per cubic meter of air.

(d) The fume will be generated by impinging an oxygen-gas flame on molten lead.

(e) Samples of the test suspension will be taken during each test period for analysis.

(f) The total amount of unretained test suspension in the samples taken during testing, which is analyzed and calculated as lead (Pb), shall not exceed 1.5 milligrams of lead for a non-powered air-purifying respirator.

**§ 84.1147 Silica mist test for dust, fume, and mist respirators; minimum requirements.**

(a) Three non-powered respirators will be tested for a period of 312 minutes each at a continuous airflow rate of 32 liters per minute.

(b) The room temperature in the test chamber will be approximately 25°C.

(c) The test suspension in the test chamber will not be less than 20 nor more than 25 milligrams of silica mist, weighed as silica dust, per cubic meter of air.

(d) Mist will be produced by spraying an aqueous suspension of flint (99+ percent free silica), and the flint shall be ground to pass 99+ percent through a 270-mesh sieve.

(e) Samples of the test suspension will be taken during each test period for analysis.

(f) The total amount of silica mist unretained in the samples taken during testing, weighed as silica dust, shall not exceed 2.5 milligrams for a non-powered air-purifying respirator.

**§ 84.1148 Tests for respirators designed for respiratory protection against more than one type of dispersoid; minimum requirements.**

Respirators designed as respiratory protection against more than one particulate hazard (dust, fume, or mist) shall comply with all the requirements of this part, with respect to each of the specific hazards involved.

**§ 84.1149 Airflow resistance tests; all dust, fume, and mist respirators; minimum requirements.**

(a) Resistance to airflow will be measured in the facepiece, mouthpiece, hood, or helmet of a dust, fume, or mist respirator mounted on a test fixture with air flowing at a continuous rate of 85 liters per minute, both before and after each test conducted in accordance with §§ 84.1144 through 84.1147.

(b) The maximum allowable resistance requirements for dust, fume, and mist respirators are as follows:

**MAXIMUM RESISTANCE**  
 [mm. water-column height]

Type of respirator	Initial inhalation	Final inhalation	Exhalation
Pneumoconiosis- and fibrosis-producing dusts, or dusts and mists .....	12	15	15
Dust, fume, and mist, with single-use filter .....	30	50	20
Dust, fume, and mist, with reusable filter .....	20	40	20
Radon daughter .....	18	25	15
Asbestos dust and mist .....	18	25	15

<sup>1</sup> Measured after silica dust test described in § 84.1144.

**§ 84.1150 Exhalation valve leakage test; minimum requirements.**

(a) Dry exhalation valves and valve seats will be subjected to a suction of 25 mm. water-column height while in a normal operating position.

(b) Leakage between the valve and valve seat shall not exceed 30 milliliters per minute.

**§ 84.1151 DOP filter test; respirators designed as respiratory protection against dusts, fumes, and mists having an air contamination level less than 0.05 milligram per cubic meter and against radionuclides; minimum requirements.**

(a) All single air-purifying respirator filter units will be tested in an atmosphere concentration of 100 micrograms of DOP per liter of air at continuous flow rates of 32 and 85 liters

per minute for a period of 5 to 10 seconds.

(b) Where filters are to be used in pairs, the flow rates will be 16 and 42.5 liters per minute, respectively, through each filter.

(c) The filter will be mounted on a connector in the same manner as used on the respirator, and the total leakage for the connector and filter shall not exceed 0.03 percent of the ambient DOP concentration at either flow rate.

**§ 84.1152 Silica dust loading test; respirators designed as protection against dusts, fumes, and mists having an air contamination level less than 0.05 milligram per cubic meter and against radionuclides; minimum requirements.**

(a) Three non-powered respirators will be tested in accordance with the

provisions of § 84.1144, or equivalent, and shall meet the minimum requirements of §§ 84.1144 and 84.1149.

(b) Three powered air-purifying respirators will be tested in accordance with the provisions of § 84.1144 except they will be tested for a period of 4 hours each at a flowrate not less than 115 liters per minute to tight-fitting facepieces, and not less than 170 liters per minute to loose-fitting hoods and helmets. The total amount of unretained test suspension in samples taken during testing shall not exceed 14.4 milligrams for a powered air-purifying respirator with tight-fitting facepiece, and 21.3 milligrams for a powered air-purifying respirator with loose-fitting hood or helmet. They shall meet the minimum requirements of § 84.1149.



**§ 84.1153 Dust, fume, mist, and smoke tests; canister bench tests; gas masks canisters containing filters; minimum requirements.**

(a) Gas mask canisters containing filters for protection against dusts, fumes, mists, and smokes in combination with gases, vapors, or gases and vapors, will be tested as prescribed in § 84.1140 except for the breathing resistance which will be in accordance with § 84.122.

(b) Gas mask canisters designed for protection against smokes will be tested in an atmospheric concentration of 100 micrograms of dioctyl phthalate per liter of air at continuous flow rates of 32 liters per minute and 85 liters per minute for a period of 5 to 10 seconds, and the DOP leakage through the canister shall not exceed 0.03 percent of the test concentration.

(c) Gas mask canisters containing filters for protection against dusts, fumes, mists, and smokes in combination with gases, vapors, or gases and vapors, will be tested as prescribed in § 84.126.

**§ 84.1154 Canister and cartridge requirements.**

(a) Where two or more canisters or cartridges are used in parallel, their resistance to airflow shall be essentially equal.

(b) The color and markings of all canisters and cartridges or labels shall conform with the requirements of the American National Standards Institute, American National Standard for Identification of Air-Purifying Respirator Canisters and Cartridges, ANSI K13.1-1973. ANSI K13.1 is incorporated by reference and has been approved by the Director of the Federal Register in accordance with 5 U.S.C. 552(a) and 1 CFR part 51. Copies may be obtained from American National Standards Institute, Inc., 1430 Broadway, New York, NY 10018. Copies may be inspected at the NIOSH, Certification and Quality Assurance Branch, 1095 Willowdale Road, Morgantown, WV 26505-2888, or at the Office of the Federal Register, 800 North Capitol Street, NW., suite 700, Washington, DC.

**§ 84.1155 Filters used with canisters and cartridges; location; replacement.**

(a) Particulate matter filters used in conjunction with a canister or cartridge shall be located on the inlet side of the canister or cartridge.

(b) Filters shall be incorporated into or firmly attached to the canister or cartridge and each filter assembly shall, where applicable, be designed to permit its easy removal from and replacement on the canister or cartridge.

**§ 84.1156 Pesticide respirators; performance requirements; general.**

Pesticide respirators and the individual components of each such device shall, as appropriate, meet the following minimum requirements for performance and protection:

(a) *Breathing resistance test.* (1) Airflow resistance will be measured in the facepiece, mouthpiece, hood, or helmet of a pesticide respirator mounted on a test fixture with air flowing at a continuous rate of 85 liters per minute, both before and after each test conducted in accordance with paragraphs (c) and (f) of this section.

(2) The maximum allowable resistance requirements for pesticide respirators are as follows:

**MAXIMUM RESISTANCE**  
[mm. water-column height]

Type of pesticide respirator	Inhalation		Exhalation
	Initial	Final <sup>1</sup>	
Front- or back-mounted gas mask .....	70	85	20
Chin-style gas mask .....	65	80	20
Powered air-purifying <sup>2</sup> .....	<sup>2</sup> 50	<sup>2</sup> 70	20
Chemical Cartridge .....	50	70	20

<sup>1</sup> Measured at end of the service life specified in Table 14 of this subpart.

<sup>2</sup> Resistance of filter(s), cartridge(s), and breathing tube(s) only with blower not operating.

(b) *Facepiece test.* (1) The complete pesticide respirator will be fitted to the faces of persons having varying facial shapes and sizes.

(2) Where the applicant specifies a facepiece size or sizes for his respirator together with the approximate measurements of faces they are designed to fit, the Institute will provide test subjects to suit such facial measurements.

(3) Any pesticide respirator part which must be removed to perform the facepiece fit test shall be replaceable without special tools and without disturbing facepiece fit.

(4) The facepiece or mouthpiece fit test using positive or negative pressure recommended by the applicant and described in his instructions will be used during each test.

(5)(i) Each wearer will enter a chamber containing 1,000 p.p.m. isoamyl-acetate vapor for a respirator equipped with a full facepiece, mouthpiece, hood, or helmet and 100 p.p.m. isoamyl-acetate vapor for a respirator equipped with a half-mask facepiece.

(ii) The facepiece, mouthpiece, hood, or helmet may be adjusted, if necessary, in the test chamber before starting the test.

(iii) Each wearer will remain in the chamber while performing the following activities:

- (A) Two minutes, nodding and turning head;
- (B) Two minutes, calisthenic arm movements;
- (C) Two minutes, running in place; and

(D) Two minutes, pumping with a tire pump into a 28-liter (1 cubic foot) container.

(iv) Each wearer shall not detect the odor of isoamyl-acetate during the test.

(c) *Silica dust test.* Three completely assembled pesticide respirators will be tested with a mechanical-testing apparatus as follows:

(1) Temperature in the test chamber will be approximately 25° C.

(2) Continuous airflow through the respirator will be 32 liters per minute for front-mounted, back-mounted, and chin-style gas mask pesticide respirators and chemical cartridge pesticide respirators, and not less than 115 (4 cubic feet) liters per minute to tight-fitting facepieces and 170 liters (6 cubic feet) per minute to loose-fitting hoods and helmets of powered air-purifying respirators.



(3) The test aerosol will contain 50–60 milligrams of 99+ percent free silica per cubic meter of air.

(4) The particle size distribution of the test suspension will have a geometric mean diameter of 0.4 to 0.6 micrometer, with a standard geometric deviation less than 2.

(5) Front-mounted, back-mounted, and chin-style gas mask pesticide respirators and chemical cartridge pesticide respirators will be tested for 90 minutes and powered air-purifying respirators will be tested for 4 hours.

(d) *Lead fume test.* Three completely assembled pesticide respirators will be tested with a mechanical-testing apparatus as follows:

(1) Continuous airflow through the respirator will be 32 liters per minute for front-mounted, back-mounted, and chin-style gas mask pesticide respirators and chemical cartridge pesticide respirators and not less than 115 liters (4 cubic feet) per minute, for powered air-purifying respirators with tight-fitting facepieces, and not less than 170 liters (6 cubic feet) per minute for powered air-purifying respirators with loose-fitting hoods and helmets.

(2) The test aerosol will contain 15–20 milligrams of freshly generated lead-oxide fume, calculated as lead, per cubic meter of air.

(3) The fume will be generated by impinging an oxygen-gas flame on molten lead.

(4) Front-mounted, back-mounted, and chin-style gas mask pesticide respirators and chemical cartridge pesticide respirators will be tested for 90 minutes and powered air-purifying pesticide respirators will be tested for 4 hours.

(5) The total amount of unretained test suspension, which is analyzed and calculated as lead, shall not exceed:

(i) 0.43 milligram for any 90-minute test;

(ii) 4.8 milligrams for any 4-hour test made at 115 liters (4 cubic feet) per minute; or

(iii) 6.2 milligrams for any 4-hour test made at 170 liters (6 cubic feet) per minute.

(e) *Diocetyl-phthalate test.* (1) All canisters submitted for use with front-mounted and back-mounted gas mask pesticide respirators will be tested in an atmospheric concentration of 100 micrograms of diocetyl-phthalate per liter of air at continuous flow rates of 32 and 85 liters per minute for a test period of 5 to 10 seconds.

(2) The DOP leakage through the canister shall not exceed 0.03 percent of the ambient DOP concentration.

(f) *Bench tests for pesticide respirators.* (1)(i) Bench tests will be made on an apparatus that allows the test atmosphere at 50±5 percent relative humidity and at room temperature (25°±2.5° C.) to enter the canister or cartridge at predetermined concentrations and rates of flow, and that has a means for determining the test life of the canister or cartridge against carbon tetrachloride.

(ii) Canisters and cartridges will be tested as they are used on each pesticide respirator, either singly or in pairs.

(iii) Three canisters or cartridges or pairs of cartridges will be removed from containers and tested as received from the applicant.

(iv) Two canisters, cartridges, or pairs of cartridges will be equilibrated at room temperature by passing 25 percent relative humidity air through them at the following flow rates (expressed as liters per minute (l.p.m.)) for 6 hours:

Type of canister or cartridge	Airflow rate, l.p.m.
Air-purifying canister .....	64
Air-purifying cartridge .....	25
Powered air-purifying with tight-fitting facepiece .....	115
Powered air-purifying with loose-fitting hood or helmet .....	170

(v) Two canisters, cartridges, or pairs of cartridges will be equilibrated at room temperature by passing 85 percent relative humidity air through them at the flow rates stated in paragraph (f)(1)(iv) of this section for 6 hours.

(vi) The equilibrated canisters or cartridges will be resealed, kept in an upright position at room temperature, and tested within 18 hours.

(2) Canisters and cartridges tested in accordance with the provisions of this section shall meet the requirements specified in Table 14 of this subpart.

**§ 84.1157 Chemical cartridge respirators with particulate filters; performance requirements; general.**

Chemical cartridge respirators with particulate filters and the individual components of each such device shall, as appropriate, meet the following minimum requirements for performance and protection:

(a) *Breathing resistance test.* (1) Resistance to airflow will be measured in the facepiece, mouthpiece, hood, or helmet of a chemical cartridge respirator mounted on a test fixture with air flowing at a continuous rate of 85 liters per minute, both before and after each test conducted in accordance with paragraphs (d) through (f) of this section.

(2) The maximum allowable resistance requirements for chemical cartridge respirators are as follows:

**MAXIMUM RESISTANCE**  
[mm. water-column height]

Type of chemical cartridge respirator	Inhalation		Exhalation
	Initial	Final <sup>1</sup>	
For gases, vapors, or gases and vapors, and dusts, fumes, and mists .....	50	70	20
For gases, vapors, or gases and vapors, and mists of paints, lacquers, and enamels .....	50	70	20

<sup>1</sup> Measured at end of service life specified in Table 11 in subpart L of this part.

(b) *Facepiece test.* The facepiece test will be conducted as specified in § 84.205.

(c) *Lacquer and enamel mist tests; general.* (1) Three respirators with cartridges containing or having attached to them, filters for protection against mists of paints, lacquers, and enamels shall be tested in accordance with the

provisions of paragraph (f) of this section.

(2) In addition to the test requirements set forth in paragraph (c)(1) of this section, three such respirators will be tested against each aerosol in accordance with the provisions of paragraphs (d) and (e) of this section.

(d) *Lacquer mist test.* (1) Temperature in the test chamber will be approximately 25° C.

(2) Continuous airflow through the respirator will be 32 liters per minute for air-purifying respirators, and not less than 115 liters per minute to tight fitting facepieces and 170 liters per minute to



loose-fitting hoods and helmets of powered air-purifying respirators.

(3) Airflow through the chamber will be 20-25 air changes per minute.

(4) The atomizer employed will be a No. 64-5 nozzle with setup 3, or equivalent, operating at 69 kN/m.<sup>2</sup> (10 pounds per square inch gage).

(5) The test aerosol will be prepared by atomizing a mixture of one volume of clear cellulose nitrate lacquer and one volume of lacquer thinner. The lacquer described in Federal Specification TT-L-31, October 7, 1953, is an example of an acceptable lacquer. Copies of TT-L-31 may be inspected or obtained from the NIOSH, Certification and Quality Assurance Branch, 1095 Willowdale Road, Morgantown, WV 26505-2888.

(6) The concentration of cellulose nitrate in the test aerosol will be 95-125 milligrams per cubic meter.

(7) The test aerosol will be drawn to each respirator for a total of 156 minutes for air-purifying respirators and 240 minutes for powered air-purifying respirators.

(8) The total amount of unretained mist in the samples taken during testing, weighed as cellulose nitrate, shall not exceed 5 milligrams for an air-purifying respirator, 28 milligrams for a powered air-purifying respirator with tight-fitting facepiece, and 41 milligrams for a powered air-purifying respirator with loose-fitting hood or helmet.

(e) *Enamel mist test.* (1) Temperature in the test chamber will be approximately 25° C.

(2) Continuous airflow through the respirator will be 32 liters per minute for air-purifying respirators, and not less than 115 liters per minute to tight-fitting facepieces and 170 liters per minute to loose-fitting hoods and helmets of powered air-purifying respirators.

(3) Airflow through the chamber will be 20-25 air changes per minute.

(4) The atomizer employed will be a No. 64 nozzle with setup 1A, or equivalent, operating at 69 kN/m.<sup>2</sup> (10 pounds per square inch gage).

(5) The test aerosol will be prepared by atomizing a mixture of 1 volume of white enamel and 1 volume of turpentine. The enamel described in Federal Specification TT-E-489b, May 12, 1953, with amendment-1 of 9 November 1955 is an example of an acceptable enamel. Copies of TT-E-489b may be inspected or obtained from the NIOSH, Certification and Quality Assurance Branch, 1095 Willowdale Road, Morgantown, WV 26505-2888.

(6) The concentration of pigment in the test aerosol, weighed as ash, will be 95-125 milligrams per cubic meter.

(7) The test aerosol will be drawn to each respirator for a total of 156 minutes for air-purifying respirators and 240 minutes for power air-purifying respirators.

(8) The total amount of unretained mist in the samples taken during testing, weighed as ash, shall not exceed 1.5 milligrams for any air-purifying respirator, 8.3 milligrams for a powered air-purifying respirator with tight-fitting facepiece, and 12.3 milligrams for a powered air-purifying respirator with loose-fitting hood or helmet.

(f) *Bench tests; gas and vapor tests.* (1) Bench tests will be made in accordance with § 84.207 and tested cartridges shall meet the minimum requirements set forth in Table 11 of subpart L of this part. Cartridges will be equilibrated in accordance with paragraph (f)(2) of this section.

(2)(i) Two powered air-purifying cartridges or pairs of cartridges will be equilibrated at room temperature by passing 25 percent relative humidity air

through them at the following flow rates (expressed in liters per minute (l.p.m.)) for 6 hours:

Type of cartridge	Airflow rate, l.p.m.
Powered air purifying with tight-fitting facepiece .....	115
Powered air purifying with loose-fitting hood or helmet .....	170

(ii) Two powered air-purifying cartridges or pairs of cartridges will be equilibrated by passing 85 percent relative humidity air through them at the flow rates stated in paragraph (f)(2)(i) of this section.

(iii) All cartridges will be resealed, kept in an upright position, at room temperatures, and tested within 18 hours.

**§ 84.1158 Dust, fume, and mist tests; respirators with filters; minimum requirements; general.**

(a) Three respirators with cartridges containing, or having attached to them, filters for protection against dusts, fumes, and mists, except the mists of paints, lacquers, and enamels, will be tested in accordance with the provisions of § 84.1157(f).

(b) In addition to the test requirements set forth in paragraph (a) of this section, three such respirators will be tested, as appropriate, in accordance with the provisions of §§ 84.1141 through 84.1152; however, the maximum allowable resistance of complete dust, fume, and mist, and gas, vapor, or gas and vapor chemical cartridge respirators shall not exceed the maximum allowable limits set forth in § 84.1157(a)(2).

**Tables to Subpart KK of Part 84**

**TABLE 12.—FACEPIECE TEST REQUIREMENTS**  
[42 CFR Part 84, Subpart KK]

Respirator types	Pressure tightness test <sup>1</sup>	Isoamyl acetate test	
		84.1141	84.1142
Dusts: Air Contamination Level not less than 0.05 mg/M <sup>3</sup> or 2 mppcf .....	X		
Fumes: Air Contamination Level not less than 0.05 mg/M <sup>3</sup> .....	X	X	
Mists: Air Contamination Level not less than 0.05 mg/M <sup>3</sup> or 2 mppcf .....	X		
Dusts, Fumes, and Mists: Air Contamination Level less than 0.05 mg/M <sup>3</sup> or 2 mppcf, and radio-nuclides .....	X		X
Radon daughters .....	X	X	
Asbestos-containing dusts and mists .....	X		

<sup>1</sup> Test is required only where applicable.



TABLE 13.—AIR-PURIFYING AND POWERED AIR-PURIFYING RESPIRATOR FILTER TESTS REQUIRED FOR APPROVAL  
[42 CFR Part 84, Subpart KK]

Respirator types	Silica dust tests			Lead fume test 84.1146	Silica mist test 84.1147	DOP test 84.1151
	84.1144	84.1145	84.1152			
Dusts: Air Contamination Level not less than 0.05 mg/M <sup>3</sup> or 2 mppcf .....	X					
Fumes: Air Contamination Level not less than 0.05 mg/M <sup>3</sup> .....				X		
Mists: Air Contamination Level not less than 0.05 mg/M <sup>3</sup> or 2 mppcf .....					X	
Dusts, Fumes, and Mists: Air Contamination Level less than 0.05 mg/M <sup>3</sup> or 2 mppcf, and radionuclides .....			X			X
Radon daughters .....	<sup>1</sup> X				<sup>2</sup> X	
Asbestos-containing dusts and mists .....	<sup>2</sup> X				<sup>3</sup> X	
Single use dust and mist respirators .....		<sup>3</sup> X			<sup>3</sup> X	

<sup>1</sup> For resistance only.

<sup>2</sup> For penetration only.

<sup>3</sup> Test required only where applicable.

TABLE 14.—CARBON TETRACHLORIDE BENCH TESTS AND REQUIREMENTS FOR CANISTERS AND CARTRIDGES  
[42 CFR part 84, Subpart KK]

Type of pesticide respirator	Test concentration p.p.m. CCl <sub>4</sub>	Flow rate l.p.m.	Number of tests	Minimum life minutes <sup>1</sup>
Chest-mounted or back-mounted gas mask (as received) .....	20,000	64	3	12
Chest-mounted or back-mounted gas mask (equilibrated) .....	20,000	32	4	12
Chin-style gas mask (as received) .....	5,000	64	3	12
Chin-style gas mask (equilibrated) .....	5,000	32	4	12
Chemical Cartridge respirator (as received) .....	1,000	64	3	50
Chemical cartridge respirator (equilibrated) .....	1,000	32	4	50
Powered air-purifying respirator (tight-fitting facepiece, as received) .....	1,000	<sup>2</sup> 115	3	50
Powered air-purifying respirator (tight-fitting facepiece, equilibrated) .....	1,000	<sup>2</sup> 115	4	25
Powered air-purifying respirator (loose-fitting hood or helmet, as received) .....	1,000	<sup>3</sup> 170	3	50
Powered air-purifying respirator (loose-fitting hood or helmet, equilibrated) .....	1,000	<sup>3</sup> 170	4	25

<sup>1</sup> Minimum life will be determined at 5 p.p.m. leakage.

<sup>2</sup> The flow rate shall be the effective flow rate of the device, but shall be not less than 115 l.p.m.

<sup>3</sup> The flow rate shall be the effective flow rate of the device, but shall be not less than 170 l.p.m.

**Note:** The following appendix will not appear in the Code of Federal Regulations.

APPENDIX A TO PREAMBLE—COMPARISON OF FINAL RULE TO PROPOSED RULE

Proposed section	Final section	Change from proposal to final
84.1	84.1	No change from proposal.
84.2	84.2	No change from proposal.
84.3		Incorporation by reference section is not included in the final rule because of format requirements of the <b>Federal Register</b> .
84.4	84.3	No change from proposal.
84.10	84.10	No change from proposal.
84.11	84.11	No change from proposal.
84.12	84.12	No change from proposal.
84.20	84.20	No change from proposal.
84.21	84.21	No change from proposal.
84.22	84.22	No change from proposal.
84.30	84.30	No change from proposal.
84.31	84.31	No change from proposal.
84.32	84.32	No change from proposal.
84.33	84.33	No change from proposal.
84.34	84.34	No change from proposal.
84.35	84.35	No change from proposal.
84.36	84.36	No change from proposal.
84.40	84.40	No change from proposal.
84.41	84.41	Changed from proposal to final rule for new incorporation by reference wording.
84.42	84.42	No change from proposal.
84.43	84.43	No change from proposal.
84.50	84.50	No change from proposal.
84.51	84.51	No change from proposal.
84.52	84.52	No change from proposal.



## APPENDIX A TO PREAMBLE—COMPARISON OF FINAL RULE TO PROPOSED RULE—Continued

Proposed section	Final section	Change from proposal to final
84.53	84.53	No change from proposal.
84.60	84.60	No change from proposal.
84.61	84.61	No change from proposal.
84.62	84.62	No change from proposal.
84.63	84.63	No change from proposal.
84.64	84.64	No change from proposal.
84.65	84.65	No change from proposal.
84.66	84.66	No change from proposal.
84.70	84.70	No change from proposal.
84.71	84.71	No change from proposal.
84.72	84.72	No change from proposal.
84.73	84.73	No change from proposal.
84.74	84.74	No change from proposal.
84.75	84.75	No change from proposal.
84.76	84.76	Changed from proposal to final rule for new incorporation by reference wording.
84.77	84.77	No change from proposal.
84.78	84.78	No change from proposal.
84.79	84.79	Changed from proposal to final rule for new incorporation by reference wording.
84.80	84.80	No change from proposal.
84.81	84.81	Changed from proposal to final rule for new incorporation by reference wording.
84.82	84.82	No change from proposal.
84.83	84.83	No change from proposal.
84.84	84.84	No change from proposal.
84.85	84.85	No change from proposal.
84.86	84.86	No change from proposal.
84.87	84.87	No change from proposal.
84.88	84.88	Changed from proposal to final rule for new incorporation by reference wording.
84.89	84.89	No change from proposal.
84.90	84.90	No change from proposal.
84.91	84.91	No change from proposal.
84.92	84.92	No change from proposal.
84.93	84.93	No change from proposal.
84.94	84.94	No change from proposal.
84.95	84.95	No change from proposal.
84.96	84.96	No change from proposal.
84.97	84.97	Changed from proposal to final rule for new incorporation by reference wording.
84.98	84.98	No change from proposal.
84.99	84.99	No change from proposal.
84.100	84.100	No change from proposal.
84.101	84.101	No change from proposal.
84.102	84.102	No change from proposal.
84.103	84.103	No change from proposal.
84.104	84.104	No change from proposal.
84.110	84.110	No change from proposal.
84.111	84.111	No change from proposal.
84.112	84.112	No change from proposal.
84.113	84.113	Changed from proposal to final rule for new incorporation by reference wording.
84.114	84.114	No change from proposal.
84.115	84.115	No change from proposal.
84.116	84.116	No change from proposal.
84.117	84.117	No change from proposal.
84.118	84.118	No change from proposal.
84.119	84.119	Changed from proposal to final rule for new incorporation by reference wording.
84.120	84.120	No change from proposal.
84.121	84.121	No change from proposal.
84.122	84.122	No change from proposal.
84.123	84.123	No change from proposal.
84.124	84.124	No change from proposal.
84.125	84.125	No change from proposal.
84.126	84.126	No change from proposal.
84.130	84.130	No change from proposal.
84.131	84.131	No change from proposal.
84.132	84.132	No change from proposal.
84.133	84.133	No change from proposal.
84.134	84.134	No change from proposal.
84.135	84.135	No change from proposal.
84.136	84.136	Changed from proposal to final rule for new incorporation by reference wording.
84.137	84.137	No change from proposal.
84.138	84.138	No change from proposal.
84.139	84.139	No change from proposal.
84.140	84.140	No change from proposal.



## APPENDIX A TO PREAMBLE—COMPARISON OF FINAL RULE TO PROPOSED RULE—Continued

Proposed section	Final section	Change from proposal to final
84.141	84.141	Changed from proposal to final rule for new incorporation by reference wording.
84.142	84.142	No change from proposal.
84.143	84.143	No change from proposal.
84.144	84.144	No change from proposal.
84.145	84.145	No change from proposal.
84.146	84.146	No change from proposal.
84.147	84.147	No change from proposal.
84.148	84.148	No change from proposal.
84.149	84.159	No change from proposal.
84.150	84.150	No change from proposal.
84.151	84.151	No change from proposal.
84.152	84.152	No change from proposal.
84.153	84.153	No change from proposal.
84.154	84.154	No change from proposal.
84.155	84.155	No change from proposal.
84.156	84.156	No change from proposal.
84.157	84.157	No change from proposal.
84.158	84.158	No change from proposal.
84.159	84.159	No change from proposal.
84.160	84.160	No change from proposal.
84.161	84.161	No change from proposal.
84.162	84.162	No change from proposal.
84.163	84.163	No change from proposal.
84.170	84.170	1. Changed to limit requirements to non-powered air-purifying respirators. Added description of non-powered air-purifying respirator. 2. Changed classification from "solid" and "liquid and solid" to "N-series, R-series, and P-series." 3. Changed efficiency level designations from A (99.97%), B(99%), and C (95%) to N100, R100, P100 (99.97%), N99, R99, P99(99%), N95, R95, and P95(95%).
84.171	84.171	Changed to limit requirements to non-powered air-purifying respirators.
84.172	84.172	No change from proposal.
84.173	84.173	No change from proposal.
84.174	84.174	No change from proposal.
84.175	84.175	No change from proposal.
84.176	84.176	No change from proposal.
84.177	84.177	No change from proposal.
84.178	84.178	No change from proposal.
84.179		Air velocity and noise levels for hoods and helmets is not included in final rule because these are applicable to powered air-purifying respirators only.
84.180	84.179	1. Changed to limit requirements to non-powered air-purifying respirators. 2. Changed classification from "solid" and "liquid and solid" to "N-series, R-series, and P-series." 3. Changed efficiency level designations from A (99.97%), B(99%), and C (95%) to N100, R100, P100 (99.97%), N99, R99, P99(99%), N95, R95, and P95(95%). 4. Changed labelling from S and L&S (e.g., Type A/L&S) to series and efficiency level (e.g., P100 particulate filter (99.97% filter efficiency level)).
84.181		Isoamyl acetate tightness test for particulate respirators with filters not intended to be replaced is not included in the final rule to avoid confusion and complications in the certification process.
84.182		Isoamyl acetate tightness test for respirators with replaceable filters is not included in the final rule to avoid confusion and complications in the certification process.
84.183	84.180	1. Changed to increase initial inhalation resistance from 30 mm water-column height to 35 mm. 2. Changed to increase initial exhalation resistance from 20 mm water-column height to 25 mm.
84.184	84.181	1. Changed to limit requirements to non-powered air-purifying respirators. 2. Changed test terminology from filter penetration to filter efficiency. 3. Changed to reduce the number of tested units from 30 to 20. 4. Changed the test acceptance criterion from a statistical treatment of results to a pass/fail criterion. 5. Changed the tolerances for measurements to address testing consistency concerns. 6. Changed aerosol loading of tested filters to add the P-series test until there is no further decrease in efficiency. 7. Changed the description of dioctyl phthalate (DOP) aerosol to add a purity requirement. 8. Changed to require only N-series filters (formerly solid only) to be preconditioned before testing. The proposal required preconditioning of all filters before testing.
84.185		Powered particulate respirator flow requirements are not included in the final rule.
84.186	84.182	No change from proposal.
84.190	84.190	No change from proposal.
84.191	84.191	No change from proposal.
84.192	84.192	No change from proposal.
84.193	84.193	Changed from proposal to final rule for new incorporation by reference wording.
84.194	84.194	No change from proposal.
84.195	84.195	No change from proposal.
84.196	84.196	No change from proposal.
84.197	84.197	No change from proposal.
84.198	84.198	No change from proposal.
84.199	84.199	No change from proposal.



## APPENDIX A TO PREAMBLE—COMPARISON OF FINAL RULE TO PROPOSED RULE—Continued

Proposed section	Final section	Change from proposal to final
84.200	84.200	No change from proposal.
84.201	84.201	No change from proposal.
84.202	84.202	No change from proposal.
84.203	84.203	No change from proposal.
84.204	84.204	No change from proposal.
84.205	84.205	No change from proposal.
84.206	84.206	No change from proposal.
84.207	84.207	No change from proposal.
84.250	84.250	No change from proposal.
84.251	84.251	No change from proposal.
84.252	84.252	No change from proposal.
84.253	84.253	No change from proposal.
84.254	84.254	No change from proposal.
84.255	84.255	No change from proposal.
84.256	84.256	No change from proposal.
84.257	84.257	No change from proposal.
84.258	84.258	No change from proposal.

Subpart KK (Dust, Fume, and Mist; Pesticide; Paint Spray; Powered Air-Purifying High Efficiency Respirators and Combination Gas Masks) has been added to the final rule to allow needed applications for extensions of approvals for dust/fume/mist respirators previously approved under 30 CFR Part 11. This subpart also includes the requirements for powered air-purifying respirators.

- 84.1100 Scope and effective dates.  
 84.1101 Definitions.  
 84.1102 Examination, inspection and testing of complete respirator assemblies; fees.  
 84.1103 Approval labels and markings; approval of contents; use.  
 84.1130 Respirators; description.  
 84.1131 Respirators; required components.  
 84.1132 Breathing tubes; minimum requirements.  
 84.1133 Harnesses; installation and construction; minimum requirements.  
 84.1134 Respirator containers; minimum requirements.  
 84.1135 Half-mask facepieces, full facepieces, hoods, helmets, and mouthpieces; fit; minimum requirements.  
 84.1136 Facepieces, hoods, and helmets; eyeieces; minimum requirements.  
 84.1137 Inhalation and exhalation valves; minimum requirements.  
 84.1138 Head harnesses; minimum requirements.  
 84.1139 Air velocity and noise levels; hoods and helmets; minimum requirements.  
 84.1140 Dust, fume, and mist respirators; performance requirements; general.  
 84.1141 Isoamyl acetate tightness test; dust, fume, and mist respirators designed for respiratory protection against fumes of various metals having an air contamination level not less than 0.05 milligram per cubic meter; minimum requirements.  
 84.1142 Isoamyl acetate tightness test; respirators designed for respiratory protection against dusts, fumes, and mists having an air contamination level less than 0.05 milligram per cubic meter, or against radionuclides; minimum requirements.

- 84.1143 Dust, fume, and mist air-purifying filter tests; performance requirements; general.  
 84.1144 Silica dust test for dust, fume, and mist respirators; single-use or reusable filters; minimum requirements.  
 84.1145 Silica dust test; non-powered single-use dust respirators; minimum requirements.  
 84.1146 Lead fume test for dust, fume, and mist respirators; minimum requirements.  
 84.1147 Silica mist test for dust, fume, and mist respirators; minimum requirements.  
 84.1148 Tests for respirators designed for respiratory protection against more than one type of dispersoid; minimum requirements.  
 84.1149 Airflow resistance tests; all dust, fume, and mist respirators; minimum requirements.  
 84.1150 Exhalation valve leakage test; minimum requirements.  
 84.1151 DOP filter test; respirators designed as respiratory protection against dusts, fumes, and mists having an air contamination level less than 0.05 milligram per cubic meter and against radionuclides; minimum requirements.  
 84.1152 Silica dust loading test; respirators designed as protection against dusts, fumes, and mists having an air contamination level less than 0.05 milligram per cubic meter and against radionuclides; minimum requirements.  
 84.1153 Dust, fume, mist, and smoke tests; canister bench tests; gas mask canisters containing filters; minimum requirements.  
 84.1154 Canister and cartridge requirements.  
 84.1155 Filters used with canisters and cartridges; location; placement.  
 84.1156 Pesticide respirators; performance requirements; general.  
 84.1157 Chemical cartridge respirators with particulate filters; performance requirements; general.  
 84.1158 Dust, fume, and mist tests; respirators with filters; minimum requirements; general.

[FR Doc. 95-13287 Filed 6-2-95; 12:10 pm]

BILLING CODE 4160-19-P

## DEPARTMENT OF LABOR

## Mine Safety and Health Administration

30 CFR Parts 11, 49, 56, 57, 58, 70, 72, 75

RIN 1219-AA85

## Respiratory Protective Devices

AGENCY: Mine Safety and Health Administration, Labor.

ACTION: Final rule.

**SUMMARY:** This final rule, in conjunction with the National Institute for Occupational Safety and Health (NIOSH) final rule published concurrently in this **Federal Register**, transfers to NIOSH existing Mine Safety and Health Administration (MSHA) regulations pertaining to the testing, performance, and joint MSHA-NIOSH approval of respirators under the Mine Act. MSHA retains existing provisions related to the selection, use, and maintenance of respirators for coal and metal and nonmetal mines. Under the NIOSH rule, MSHA retains joint approval responsibility for certain mining-related respiratory protective devices. MSHA's transfer of the respirator approval program to NIOSH will more accurately reflect the respective roles of the two agencies in the approval of respirators. A memorandum of understanding (MOU) between MSHA and NIOSH delineates the roles of both agencies in the respirator approval program. This MOU is published elsewhere in this separate part of the **Federal Register**. MSHA's final rule will not affect the compliance responsibilities of mine operators.

**EFFECTIVE DATE:** This final rule is effective on July 10, 1995. The incorporation by reference of certain